

City of Portland, Maine - Building or Use Permit Application

389 Congress Street, 04101 Tel: (207) 874-8703, Fax: (207) 874-8716

Permit No: 06-0697	Issue Date: PERMIT ISSUED JUN 14 2006	CBL: 186A DD21001
-----------------------	--	----------------------

Location of Construction: 193 WHITNEY AVE	Owner Name: VANDERBURGH CHARLES A	Owner Address: 193 WHITNEY AVE	Phone:
Business Name:	Contractor Name: Northeast Pool Builders	Contractor Address: 660 Townhouse Road East Waterboro	Phone: 207-2478315
Lessee/Buyer's Name	Phone:	Permit Type: Swimming Pools	Zone: R3

Past Use: Single Family Home	Proposed Use: Single Family Home/ install a 24' diameter x 52' High pool	Permit Fee: \$39.00	Cost of Work: \$1,100.00	CEO District: 3
--	--	-------------------------------	------------------------------------	---------------------------

FIRE DEPT: <input type="checkbox"/> Approved <input type="checkbox"/> Denied <i>N/A</i>	INSPECTION: Use Group: <i>U</i> Type: <i>Pool</i> <i>IRC 2005</i>
Signature: <i>[Signature]</i>	Signature: <i>[Signature]</i>

Proposed Project Description:
install a 24' diameter x 52' High pool

PEDESTRIAN ACTIVITIES DISTRICT (P.A.D.)

Action Approved Approved w/Conditions Denied

Signature _____ Date _____

Permit Taken By: Idobson	Date Applied For: 05/10/2006	Zoning Approval		
------------------------------------	--	------------------------	--	--

<ol style="list-style-type: none"> This permit application does not preclude the Applicant(s) from meeting applicable State and Federal Rules. Building permits do not include plumbing, septic or electrical work. Building permits are void if work is not started within six (6) months of the date of issuance. False information may invalidate a building permit and stop all work.. 	Special Zone or Reviews <input type="checkbox"/> Shoreland <input type="checkbox"/> Wetland <input type="checkbox"/> Flood Zone <input type="checkbox"/> Subdivision <input type="checkbox"/> Site Plan Maj <input type="checkbox"/> Minor @ MM <input type="checkbox"/> <i>OK w/cond. change</i> Date: <i>5/25/06</i>	Zoning Appeal <input type="checkbox"/> Variance <input type="checkbox"/> Miscellaneous <input type="checkbox"/> Conditional Use <input type="checkbox"/> Interpretation <input type="checkbox"/> Approved <input type="checkbox"/> Denied Date: _____	Historic Preservation <input checked="" type="checkbox"/> Not in District or Landmark <input type="checkbox"/> Does Not Require Review <input type="checkbox"/> Requires Review <input type="checkbox"/> Approved <input type="checkbox"/> Approved w/Conditions <input type="checkbox"/> Denied <i>ABM</i> Date: _____
---	---	---	--

CERTIFICATION

I hereby certify that I am the owner of record of the named property, or that the proposed work is authorized by the owner of record and that I have been authorized by the owner to make this application as his authorized agent and I agree to conform to all applicable laws of this jurisdiction. In addition, if a permit for work described in the application is issued, I certify that the code official's authorized representative shall have the authority to enter all areas covered by such permit at any reasonable hour to enforce the provision of the code(s) applicable to such permit.

SIGNATURE OF APPLICANT	ADDRESS	DATE	PHONE
RESPONSIBLE PERSON IN CHARGE OF WORK, TITLE		DATE	PHONE

DISPLAY THIS CARD ON PRINCIPAL FRONTAGE OF WORK CITY OF PORTLAND

Please Read
Application And
Notes, If Any,
Attached

BUILDING INSPECTION PERMIT

PERMIT ISSUED
Permit Number: 060697
JUN 14 2006
CITY OF PORTLAND

This is to certify that VANDEBURGH CHARLES A /Northeast Pool Builders

has permission to install a 24' diameter x 52' H pool

AT 193 WHITNEY AVE

186A D021001

provided that the person or persons who accept this permit shall comply with all of the provisions of the Statutes of the State and of the Ordinances of the City of Portland regulating the construction, maintenance and use of buildings and structures, and of the application on file in this department.

Apply to Public Works for street line and grade if nature of work requires such information.

Notification of inspection must be given and when permission proceeds before this building or part thereof is started or service closed-in. 4 HOUR NOTICE REQUIRED.

A certificate of occupancy must be procured by owner before this building or part thereof is occupied.

OTHER REQUIRED APPROVALS

Fire Dept. _____
Health Dept. _____
Appeal Board _____
Other _____
Department Name

[Signature] 6/13/06
Director - Building & Inspection Services

PENALTY FOR REMOVING THIS CARD

City of Portland, Maine - Building or Use Permit

389 Congress Street, 04101 Tel: (207) 874-8703, Fax: (207) 874-8716

Permit No: 06-0697	Date Applied For: 05/10/2006	CBL: 186AD021001
------------------------------	--	----------------------------

Location of Construction: 193 WHITNEY AVE	Owner Name: VANDERBURGH CHARLES A	Owner Address: 193 WHITNEY AVE	Phone:
Business Name:	Contractor Name: Northeast Pool Builders	Contractor Address: 660 Townhouse Road East Waterboro	Phone (207) 247-8315
Tenant/Leasee/Buyer's Name	Phone:	Permit Type: Swimming Pools	

Proposed Use: Single Family Home/ install a 24' diameter x 52' High pool	Proposed Project Description: install a 24' diameter x 52' High pool
--	--

Dept: Zoning **Status:** Approved with Conditions **Reviewer:** Ann Machado **Approval Date:** 05/25/2006

Note: **Ok to Issue:**

- 1) This permit is being issued with the understanding that the pool must be at least 10' from the rear and side property line, and must be confirmed by an inspector.

Dept: Building **Status:** Approved with Conditions **Reviewer:** Tammy Munson **Approval Date:** 06/13/2006

Note: **Ok to Issue:**

- 1) Separate permits are required for any electrical, plumbing, or heating.

Comments:

5/25/06-amachado: Left message with Chuck Vanderburgh. Distances from side and rear property lines and from rear of house need to be more specific.



Pool Installation/Construction Permit Application

If you or the property owner owes real estate or personal property taxes or user charges on any property within the City, payment arrangements must be made before permits of any kind are accepted.

Location/Address of Construction: <u>193 Whitney Ave. Portland</u>		
Total Square Footage of Proposed Structure <u>Pool</u>		Square Footage of Lot
<u>24' Diameter x 52" Height</u>		
Tax Assessor's Chart, Block & Lot		Owner
Chart# <u>186</u>	Block# <u>AD</u>	Lot# <u>21</u>
Lessee/Buyer's Name (If Applicable)		Applicant name, address & telephone: <u>Charles A. VanDerburgh</u> <u>193 Whitney Ave.</u> <u>Portland, ME 04102</u>
		Telephone: <u>773-9651</u>
		Cost Of Work: \$ <u>1100.00</u> Fee: \$ <u>39.00</u>
Dimensions of pool: <u>24' diameter x 52" ht</u> above or below ground <u>Above Ground</u>		
Dimensions of decking and/or any platforms, sheds, or other structures: <u>NA</u>		
Contractor's name, address & telephone: <u>Northeast Pool Builders 40 Dennis Bridges 660 Townhouse Rd.</u> <u>ph: 247-8315</u> <u>East Waterboro ME</u>		
Who should we contact when the permit is ready: <u>Chuck VanDerburgh</u> <u>04030</u>		
Mailing address: <u>193 Whitney Ave</u> <u>Portland ME 04102</u> Phone: <u>773-9651</u>		

Please submit all of the information outlined in the pool application checklist. Failure to do so could result in the automatic denial of your permit.

In order to be sure the City fully understands the full scope of the project, the Planning and Development Department may request additional information prior to the issuance of a permit. For further information visit us on-line at www.portlandmaine.gov, stop by the Building Inspections office, room 315 City Hall or call 874-8703.

I hereby certify that I am the Owner of record of the named property, or that the owner of record authorizes the proposed work and that I have been authorized by the owner to make this application as his/her authorized agent. I agree to conform to all applicable laws of this jurisdiction. In addition, if a permit for work described in this application is issued, I certify that the Code Official's authorized representative shall have the authority to enter all areas covered by this permit at any reasonable hour to enforce the provisions of the codes applicable to this permit.

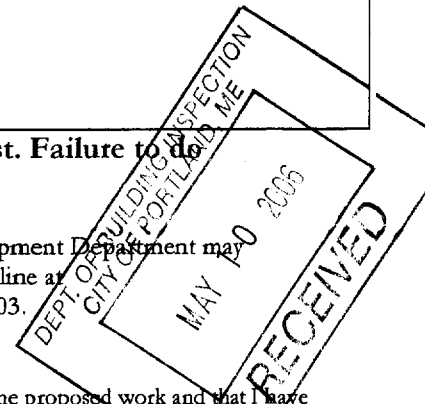

Signature of applicant:	Date: <u>5-10-6</u>
-------------------------	---------------------

This is not a permit; you may not commence ANY work until the permit is issued.

Charles A. Vanderburgh
 193 Whitney Ave
 Portland ME 04102
 PH# 773-9651

Fence All The way Around
 Cedar Stocked Fence

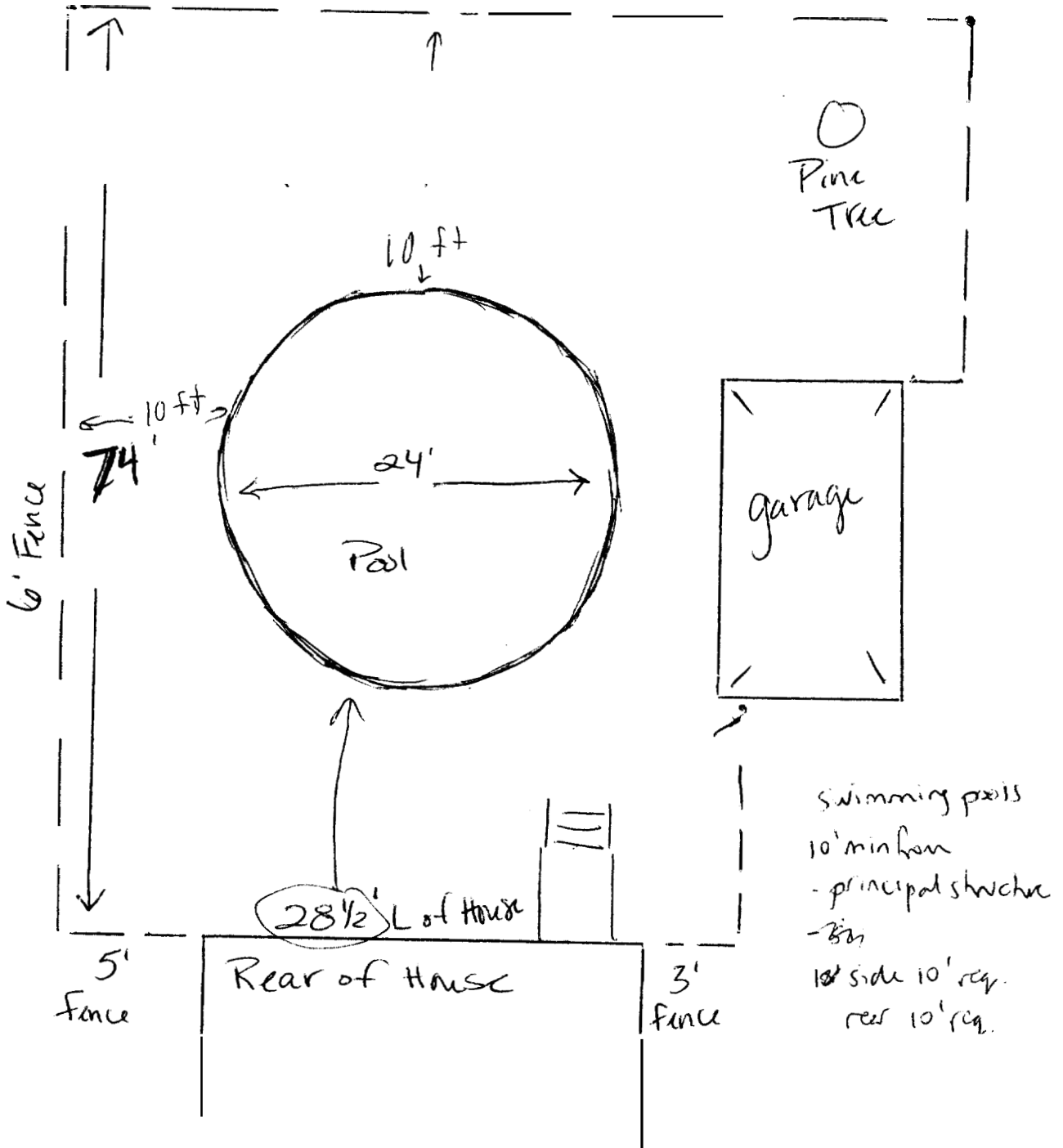

Swimming pools
 10' min from
 - principal structure
 - 3m
 10' side 10' req.
 rear 10' req.

← 36 1/2' →

lot corner

240
630
452
<hr/>
217.5

016, 1332214

This page contains a detailed description of the Parcel ID you selected. Press the **New Search** button at the bottom of the screen to submit a new query.

Current Owner Information

Card Number	1 of 1
Parcel ID	186A D021001
Location	193 WHITNEY AVE
Land Use	SINGLE FAMILY
Owner Address	VANDEBURGH CHARLES A 193 WHITNEY AVE PORTLAND ME 04102
Book/Page	17219/067
Legal	186A-D- 21 WHITNEY AVE 193 6050 SF

Current Assessed Valuation For Fiscal Year 2006

Land	Building	Total
\$59,040	\$98,160	\$157,200

Estimated Assessed Valuation For Fiscal Year 2007*

Land	Building	Total
\$87,200	\$114,000	\$201,200

* Value subject to change based upon review of property status as of 4/1/06. The tax rate will be determined by City Council in May 2006.

Property Information

Year Built 1937	Style Garrison	Story Weight 2	Sq. Ft. 1290	Total Acres 0.139		
Bedrooms 3	Full Baths 1	Half Baths 1	Total Rooms 7	Attic None	Basement Full	

Outbuildings

Type GARAGE-WD/CB	Quantity 1	Year Built 1937	Size 12x20	Grade D	Condition F
-----------------------------	----------------------	---------------------------	----------------------	-------------------	-----------------------

Sales Information

Date	Type	Price	Book/Page
-------------	-------------	--------------	------------------

Picture and Sketch

Picture	Sketch	Tax Map
---------	--------	---------

[Click here](#) to view Tax Roll Information.

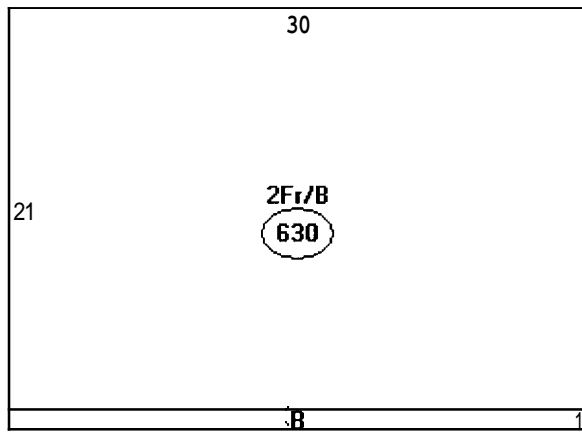

Descriptor/Area

A: 2Fr/B
630 sqft

B: FOH
30 sqft

B

- 1) Insert the three posts into the post ends and secure them in place with the screws provided
- 2) Insert the platform over the 2 rear posts
- 3) Insert the small and large handrails as illustrated. Secure the large handrails with the screws provided. Place the small handrails at the base of the large and secure them in place with the screws provided.

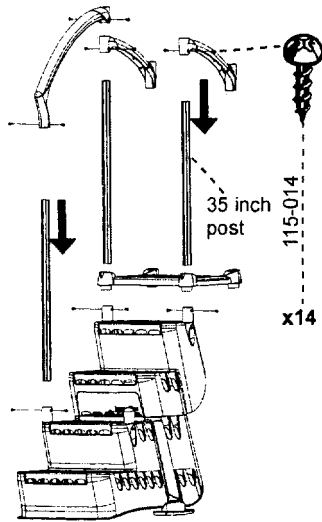

C

- 1) Install the four post covers
- 2) Insert a bag of sand onto surface provided at the rear of the step

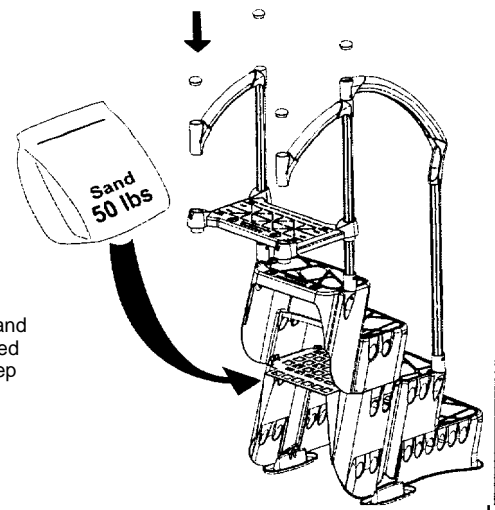

D

- 1) Slowly submerge the Step in the pool. Make sure you do not damage the liner in the process.
- 2) Once the step is in the pool secure the platform to the top seat (see illustration) using the two straps provided

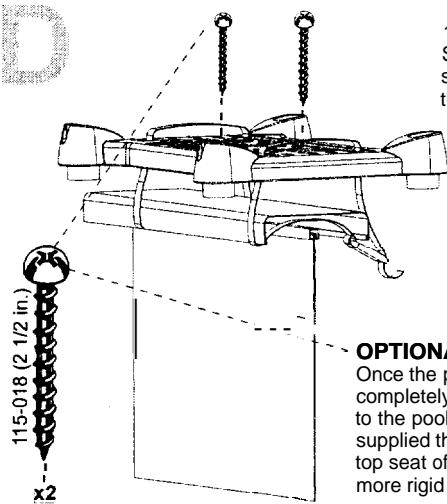

OPTIONAL:
Once the pool step has been completely assembled and secured to the pool, attach the 2 screws supplied through the platform to the top seat of your pool to provide a more rigid assembly.

E

- 1) Insert the 2 posts into the rear holes of the step.
- 2) Force the posts to a vertical position flush with the rear surface and secure in place with the bolts and nuts provided
- 3) Insert the post covers

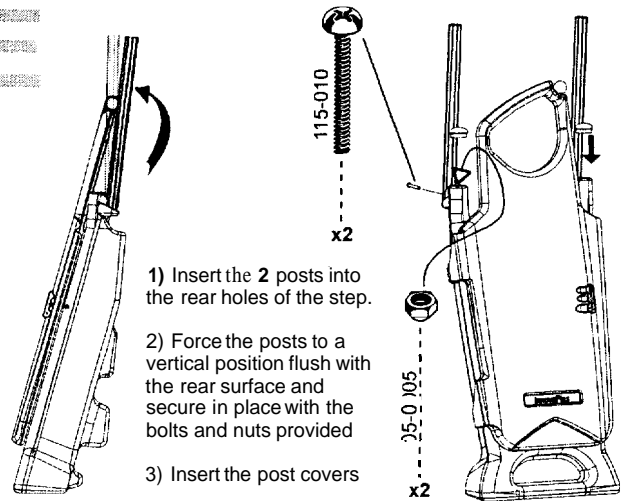

F

- 1) Slide the Self Latching posts through the platform and small handrails.
- 2) Secure the platform using the screws provided.
- 3) Secure the small handrails to the posts with the screws provided

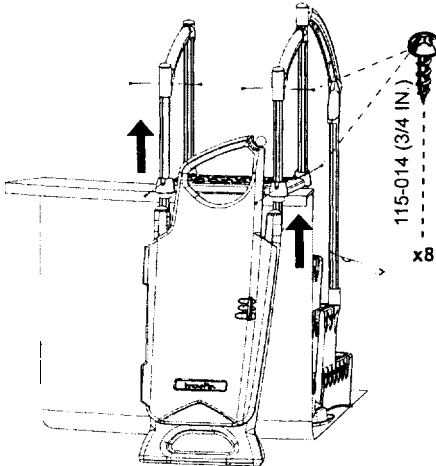

G

⚠ WARNING
LOCK THE DOOR TO THE STEP WITH A KEY WHEN THE POOL IS NOT IN USE TO PREVENT UNAUTHORIZED HORIZONTAL ENTRY

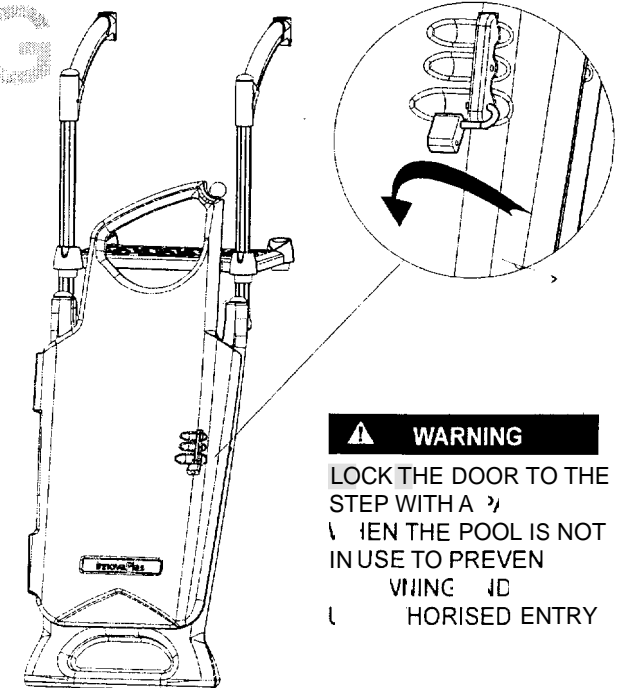

InnovaPlas
Products

101, Boul. Industriel
Bromptonville (Quebec),
Canada JOB 1HD

MANUFACTURER WARRANTY

2 Years on the Self-Latching System
1 year on the hardware

REV. 22112105

B

1) Snap the four post ends into the step making sure that the cylindrical part is vertical and that the ends are snapped properly in their respective housings.

2) Snap the 2 feet to the bottom of the step.

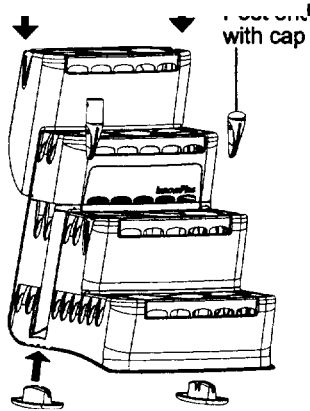
**D**

1) Place the sandbag in the step

2) Install the small post covers.

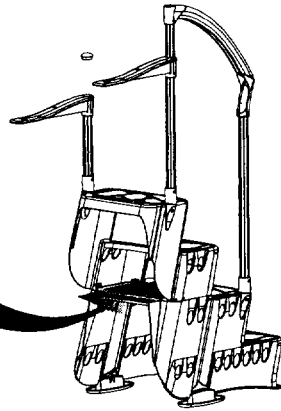
**F**

1) Slowly submerge the Step into pool. Make sure you do not damage the pool liner in the process

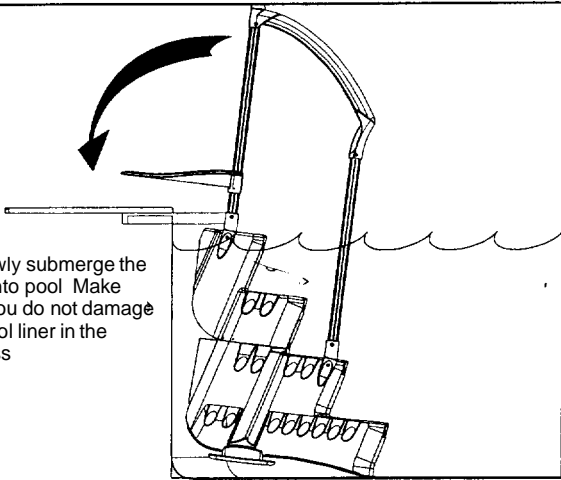

InnovaPlas
Products

MANUFACTURER WARRANTY

2 years on the Biltmor.

1 year on the hardware.

101, Boul. Industriel
Bromptonville (Quebec),
Canada JOB 1HO

REV. 23/12/05

C

1) Insert the 3 posts into the post ends and secure them in place with the screws provided.

2) Insert the two deck supports over the 2 rear posts.

3) Install the handrail as shown on the 2 posts and secure in place.

OPTIONAL:
IF YOU HAVE A 40 INCH HIGH POOL YOU WILL NEED TO USE THE 35 INCH UNUSED POST FROM THE BILTMOR BOX AND CUT IT TO ROUGHLY 10 INCHES LONG.

13 7/8 INCH POST FROM DECK KIT BOX. USED FOR 52 INCH POOLS

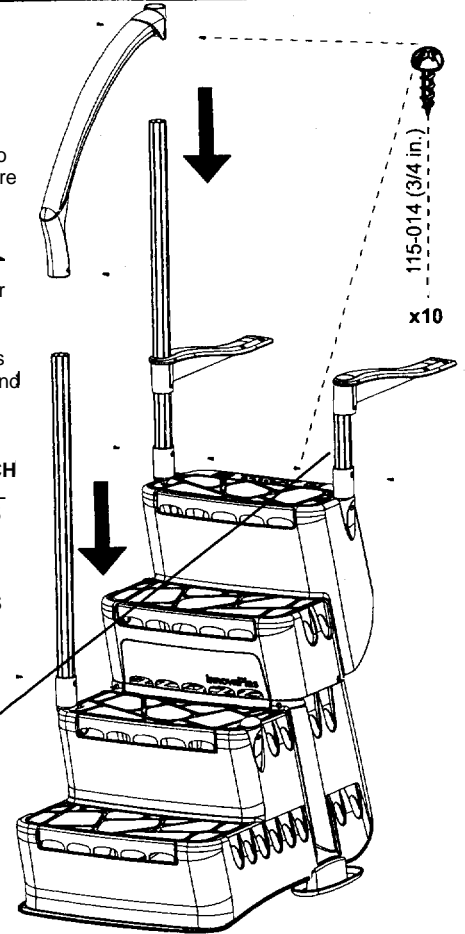
**F**

1) Affix the deck supports with the screws supplied.

2) Fasten the supports to the two rear post.

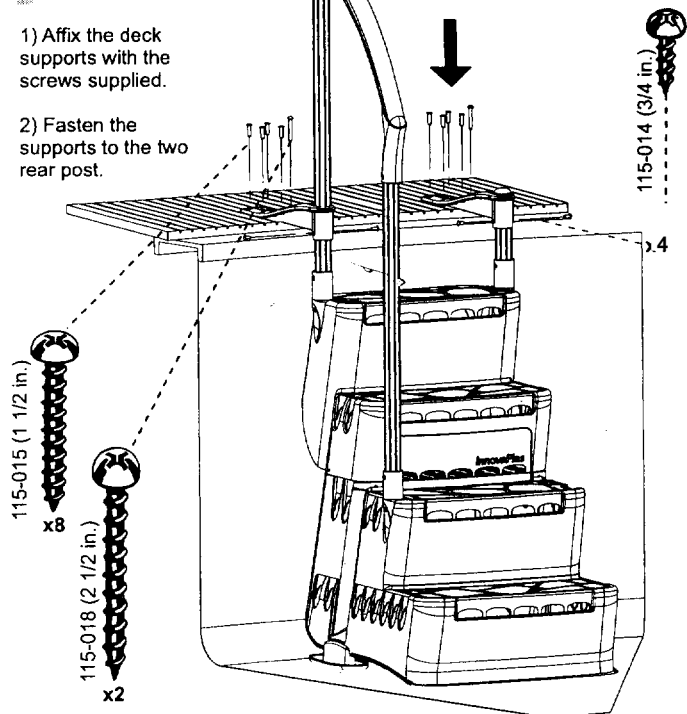

BILTMOR ASSEMBLY WITH SELF-LATCHING

Contents of Self-Latching box SKU # 9600

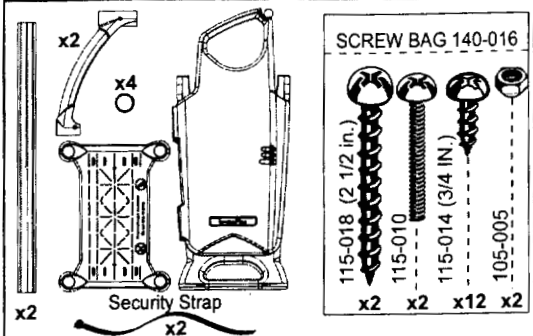

Contents of the Biltmor box SKU # 5015

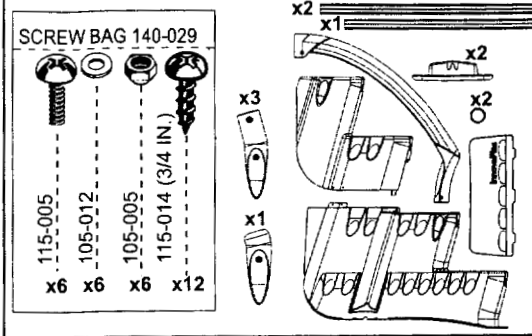

Sand (not included)

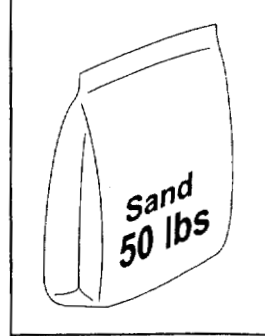

⚠ WARNING

- ◆ Do not dive or jump from step or ladder.
- ◆ Use BATTERY operated tools to avoid electric shocks.
- ◆ install step on flat surface, following the manufacturers instructions.
- ◆ Remove step from pool during freezing climate season.
- ◆ Manufacturer cannot be held responsible for injuries caused by abusive use of product.
- ◆ Ask your city about specific regulations that apply to your above-ground pool and ladder.

Required tools and supplies (not included)

A weather resistant padlock is recommended. Maximum functional width is 1/4 inch.

pliers / vice grip (or a wrench 7/16")

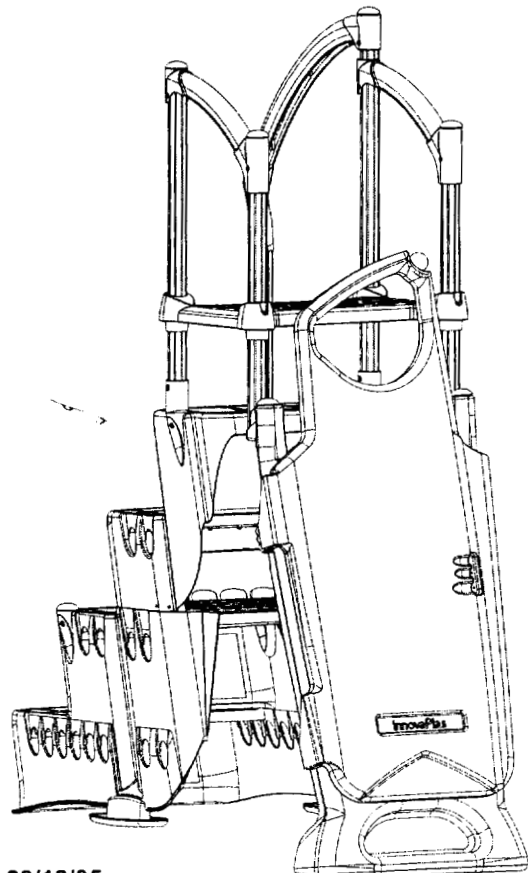

A

- 1) Assemble the two main modules with the six screws, nuts and washers provided
- 2) Snap the door between the top and bottom modules within the slots provided
- 3) Snap the four post ends into the step making sure that the cylindrical part is vertical and that the ends are placed and fitted properly in their respective housings.