

DISPLAY THIS CARD ON PRINCIPAL FRONTAGE OF WORK



# CITY OF PORTLAND

# BUILDING PERMIT

This is to certify that PATRICIA A RYBAK

Located At 175 WHITNEY AVE

Job ID: 2012-10-5169-HVAC

CBL: 186A-D-004-001

has permission to Harman Accentra Pellet Insert in living room  
provided that the person or persons, firm or corporation accepting this permit shall comply with all of the provisions of the Statues of Maine and of the Ordinances of the City of Portland regulating the construction, maintenance and use of the buildings and structures, and of the application on file in the department.

Notification of inspection and written permission procured before this building or part thereof is lathed or otherwise closed-in. 48 HOUR NOTICE IS REQUIRED.

A final inspection must be completed by owner before this building or part thereof is occupied. If a certificate of occupancy is required, it must be

\_\_\_\_\_  
**Fire Prevention Officer**

\_\_\_\_\_  
**Code Enforcement Officer / Plan Reviewer**

10/17/2012

**THIS CARD MUST BE POSTED ON THE STREET SIDE OF THE PROPERTY  
PENALTY FOR REMOVING THIS CARD**

## BUILDING PERMIT INSPECTION PROCEDURES

Please call 874-8703 or 874-8693 (ONLY)

or email: [buildinginspections@portlandmaine.gov](mailto:buildinginspections@portlandmaine.gov)

With the issuance of this permit, the owner, builder or their designee is required to provide adequate notice to the city of Portland Inspections Services for the following inspections. Appointments must be requested 48 to 72 hours in advance of the required inspection. The inspection date will need to be confirmed by this office.

- **Please read the conditions of approval that is attached to this permit!! Contact this office if you have any questions.**
- **Permits expire in 6 months. If the project is not started or ceases for 6 months.**
- **If the inspection requirements are not followed as stated below additional fees may be incurred due to the issuance of a "Stop Work Order" and subsequent release to continue.**

### Final Inspection

The project cannot move to the next phase prior to the required inspection and approval to continue, REGARDLESS OF THE NOTICE OF CIRCUMSTANCES.

IF THE PERMIT REQUIRES A CERTIFICATE OF OCCUPANCY, IT MUST BE PAID FOR AND ISSUED TO THE OWNER OR DESIGNEE BEFORE THE SPACE MAY BE OCCUPIED.



# PORTLAND MAINE

*Strengthening a Remarkable City, Building a Community for Life • [www.portlandmaine.gov](http://www.portlandmaine.gov)*

Director of Planning and Urban Development  
Jeff Levine

Job ID: 2012-10-5169-HVAC

Located At: 175 WHITNEY AVE

CBL: 186A- D-004-001

## **Conditions of Approval:**

### **Building**

1. This appliance/stove shall be installed, operated and maintained per the manufacturers specifications and the UL listing.

**City of Portland, Maine - Building or Use Permit Application**

389 Congress Street, 04101 Tel: (207) 874-8703, FAX: (207) 8716

Job No: 2012-10-5169-HVAC	Date Applied: 10/15/2012	CBL: 186A- D-004-001	
Location of Construction: 175 WHITNEY AVE	Owner Name: PATRICIA A RYBAK	Owner Address: 175 WHITNEY AVE PORTLAND, ME 04102	Phone:
Business Name:	Contractor Name: Frost & Flame Inc.	Contractor Address: 621 MAIN STREET, GORHAM, ME 04038	Phone: 856-1000 / 856-7000
Lessee/Buyer's Name:	Phone:	Permit Type: HVAC	Zone: R-3
Past Use:  Single Family Dwelling	Proposed Use:  Same: Single Family Dwelling - to install Harman Accentra pellet stove inserted to existing fireplace in living room	Cost of Work: \$6,000.00	CEO District:
		Fire Dept:  Approved Denied N/A	Inspection: Use Group: R-3 Type: SB HVAC
Proposed Project Description: Harman Accentra Pellet Insert in living room		Pedestrian Activities District (P.A.D.)	
Permit Taken By: Lannie		<b>Zoning Approval</b>	

<p>1. This permit application does not preclude the Applicant(s) from meeting applicable State and Federal Rules.</p> <p>2. Building Permits do not include plumbing, septic or electrical work.</p> <p>3. Building permits are void if work is not started within six (6) months of the date of issuance. False informatin may invalidate a building permit and stop all work.</p>	<p><b>Special Zone or Reviews</b></p> <p><input type="checkbox"/> Shoreland</p> <p><input type="checkbox"/> Wetlands</p> <p><input type="checkbox"/> Flood Zone</p> <p><input type="checkbox"/> Subdivision</p> <p><input type="checkbox"/> Site Plan</p> <p><input type="checkbox"/> Maj <input type="checkbox"/> Min <input type="checkbox"/> MM</p> <p>Date: <u>10/15/12</u></p>	<p><b>Zoning Appeal</b></p> <p><input type="checkbox"/> Variance</p> <p><input type="checkbox"/> Miscellaneous</p> <p><input type="checkbox"/> Conditional Use</p> <p><input type="checkbox"/> Interpretation</p> <p><input type="checkbox"/> Approved</p> <p><input type="checkbox"/> Denied</p> <p>Date:</p>	<p><b>Historic Preservation</b></p> <p><input checked="" type="checkbox"/> Not in Dist or Landmark</p> <p><input type="checkbox"/> Does not Require Review</p> <p><input type="checkbox"/> Requires Review</p> <p><input type="checkbox"/> Approved</p> <p><input type="checkbox"/> Approved w/Conditions</p> <p><input type="checkbox"/> Denied</p> <p>Date: <u>[Signature]</u></p>
	<b>CERTIFICATION</b>		

I hereby certify that I am the owner of record of the named property, or that the proposed work is authorized by the owner of record and that I have been authorized by the owner to make this application as his authorized agent and I agree to conform to all applicable laws of this jurisdiction. In addition, if a permit for work described in the appication is issued, I certify that the code official's authorized representative shall have the authority to enter all areas covered by such permit at any reasonable hour to enforce the provision of the code(s) applicable to such permit.

SIGNATURE OF APPLICANT	ADDRESS	DATE	PHONE
RESPONSIBLE PERSON IN CHARGE OF WORK, TITLE		DATE	PHONE



FILL IN AND Sign WITH INK

# APPLICATION FOR PERMIT HEATING OR POWER EQUIPMENT

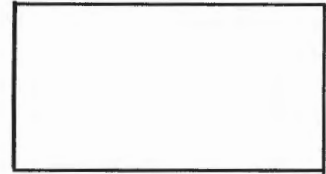

R-3

To the INSPECTOR OF BUILDINGS, PORTLAND, ME.

The undersigned hereby applies for a permit to install the following heating, cooking or power equipment in accordance with the Laws of Maine, the Building Code of the City of Portland, and the following specifications:

Location / CBL 186A D004001 Use of Building Home Date 10/3/12  
 Name and address of owner of appliance Patricia Rybak 175 Whitney Ave  
Portland Maine 04102  
 Installer's name and address Frost n' Flame Inc 621 Main St Gorham 04038  
 Telephone 856-1001 / 856-7000

Location of appliance:

- Basement
- Floor
- Attic
- Roof

Type of Fuel:

- Gas
- Oil
- Solid pellet

Appliance Name: Harman Accentra pellet stove  
 U.L. Approved  Yes  No insul

Will appliance be installed in accordance with the manufacture's installation instructions?  Yes  No

IF NO Explain: Fireplace going into existing fireplace in living room

The Type of License of Installer:

- Master Plumber # \_\_\_\_\_
- Solid Fuel# \_\_\_\_\_
- Oil# \_\_\_\_\_
- Gas# \_\_\_\_\_
- Other- \_\_\_\_\_

Type of Chimney:

- Masonry Lined
- Factory built

Metal  
 Factory Built U.L. Listing # \_\_\_\_\_

Direct Vent  
 Type \_\_\_\_\_ UL# \_\_\_\_\_

Type of Fuel Tank

- Oil
- Gas

Size of Tank \_\_\_\_\_

Number of Tanks \_\_\_\_\_

Distance from Tank to Center of Flame \_\_\_\_\_ feet.

Cost of Work: \$ 5435.40

Permit Fee: \$ 80

RECEIVED  
 OCT 15 2012  
 Dept. of Building Inspections  
 City of Portland Maine

Approved

Approved with Conditions

Fire: \_\_\_\_\_

See attached letter or requirement

Ele.: \_\_\_\_\_

Bldg.: \_\_\_\_\_

Inspector's Signature

Date Approved

Signature of Installer [Signature] 10/15/12

White - Inspection    Yellow - File    Pink - Applicant's    Gold - Assessor's Copy

## Installation & Operating Manual

# The Harman Accentra Pellet Insert

# HARMAN™

HOME HEATING

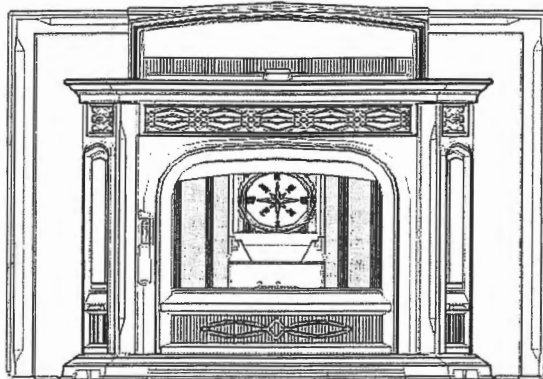

This Fireplace insert may be installed into a masonry fireplace, an approved manufactured wood burning fireplace (see page 25), Or, It may be built in to a wall or mantle system when using the optional zero clearance cabinet (see page 26).



We suggest that our hearth products be installed and serviced by professionals who are certified in the U.S. by the National Fireplace Institute (NFI) as NFI Specialists.

*“Ce manuel est disponible en Français sur demande”*



## SAFETY NOTICE

**PLEASE READ THIS ENTIRE MANUAL BEFORE YOU INSTALL AND USE YOUR NEW ROOM HEATER. FAILURE TO FOLLOW INSTRUCTIONS MAY RESULT IN PROPERTY DAMAGE, BODILY INJURY, OR EVEN DEATH.**

**FOR USE IN THE U.S. AND CANADA. SUITABLE FOR INSTALLATION IN MOBILE HOMES**

**IF THIS APPLIANCE IS NOT PROPERLY INSTALLED, A HOUSE FIRE MAY RESULT. FOR YOUR SAFETY, FOLLOW INSTALLATION DIRECTIONS. DO NOT USE MAKESHIFT COMPROMISES.**

**CONTACT LOCAL BUILDING OR FIRE OFFICIALS ABOUT RESTRICTIONS AND INSTALLATION INSPECTION REQUIREMENTS IN YOUR AREA.**

**CONTACT YOUR LOCAL AUTHORITY (SUCH AS MUNICIPAL BUILDING DEPARTMENT, FIRE DEPARTMENT, FIRE PREVENTION BUREAU, ETC.) TO DETERMINE THE NEED FOR A PERMIT.**

**CETTE GUIDE D'UTILISATION EST DISPONIBLE EN FRANCAIS. CHEZ VOTRE CONCESSIONNAIRE DE HARMAN.**

**SAVE THESE INSTRUCTIONS.**

Item# 3-90-00674

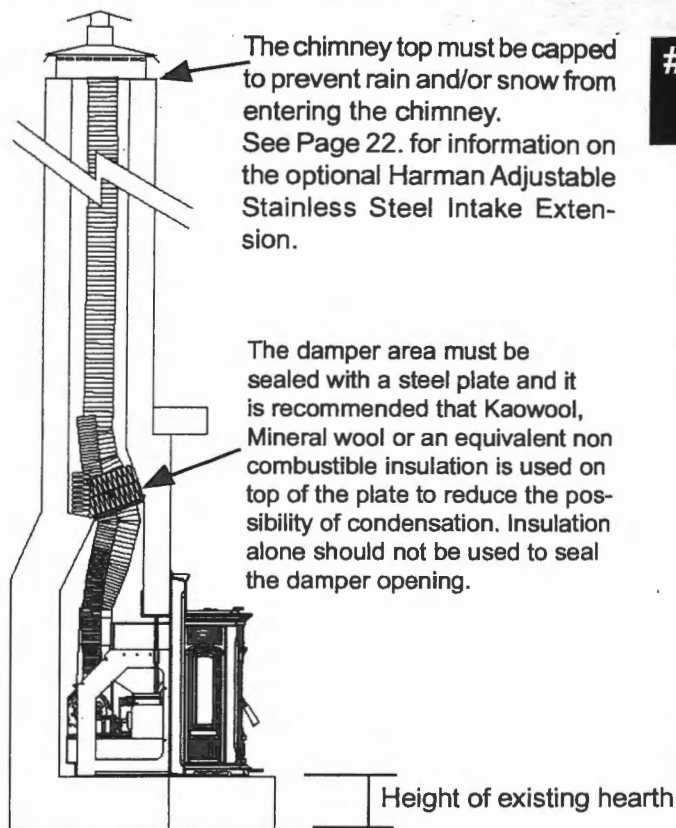

Fig. 49

## #1 Installing into an existing fireplace chimney

This method provides excellent venting with 100% outside air which is the most efficient operation of this unit. This method also provides natural draft in the event of a power failure.

A 4 inch stainless steel flex pipe is needed for the flue pipe, and 3" aluminum or Stainless Steel Flex Pipe is used for the intake.

**WARNING**  
**CHIMNEY CONNECTOR PIPE MAY NOT PASS THROUGH CONCEALED SPACES INCLUDING AN ATTIC, ROOF SPACE, CLOSET, FLOOR OR CEILING.**

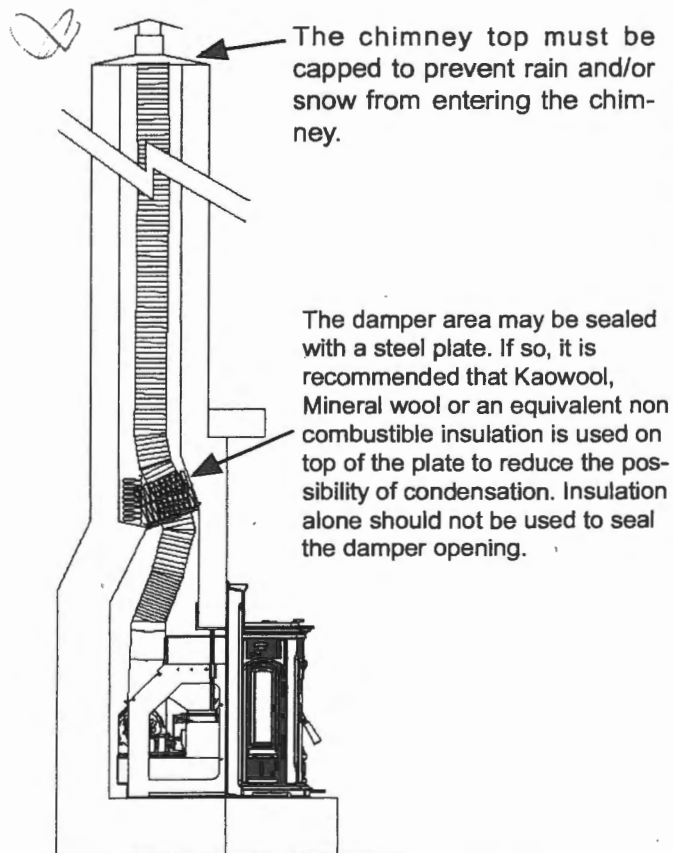

Fig. 50

## #2 Installing into an existing fireplace chimney

This method provides excellent venting for normal operation. This method also provides natural draft in the event of a power failure.

A cap should be installed on the chimney to keep out rain.

Combustion air is provided from the living area and enters the feed system from around the wing and stove body spaces.