

Form # P 04

DISPLAY THIS CARD ON PRINCIPAL FRONTAGE OF WORK CITY OF PORTLAND

Please Read
Application And
Notes, if Any,
Attached

BUILDING INSPECTION PERMIT

PERMIT ISSUED

Permit Number: 100493

MAY 24 2010

CITY OF PORTLAND

This is to certify that ST PATRICK'S SCHOOL CONDOMINIUMS LLC/Darling Plumbi
has permission to install 1.5 Embassy 45AN Gas-fired boiler
AT 1251 CONGRESS ST CBL 186-A003001

provided that the person or persons, firm or corporation accepting this permit shall comply with all of the provisions of the Statutes of Maine and of the Ordinances of the City of Portland regulating the construction, maintenance and use of buildings and structures, and of the application on file in this department.

Apply to Public Works for street line and grade if nature of work requires such information.

Notification of inspection must be given and written permission procured before this building or part thereof is lathed or otherwise closed-in. 24 HOUR NOTICE IS REQUIRED.

A certificate of occupancy must be procured by owner before this building or part thereof is occupied.

OTHER REQUIRED APPROVALS

Fire Dept. [Signature]
Health Dept. [Signature]
Appeal Board _____
Other _____

Department Name

Director's Building & Inspection Services

PENALTY FOR REMOVING THIS CARD

City of Portland, Maine - Building or Use Permit Application

389 Congress Street, 04101 Tel: (207) 874-8703, Fax: (207) 874-8716

Permit No: 10-0493	Issue Date:	CBL: 186 A003001
-----------------------	-------------	---------------------

Location of Construction: 1251 CONGRESS ST	Owner Name: ST PATRICK'S SCHOOL CONDO	Owner Address: 30 LIZA HARMON DR	Phone:
Business Name:	Contractor Name: Darling Plumbing & Heating	Contractor Address: 27 Vannah Ave Portland	Phone: 2077739525
Lessee/Buyer's Name	Phone:	Permit Type: HVAC	Zone: C53

Past Use: Residential 15 unit Condominium	Proposed Use: Residential 15 unit Condominium - install 15 Embassy 45AN Gas-fired boiler	Permit Fee: \$1,120.00	Cost of Work: \$109,500.00	CEO District: 3
--	---	---------------------------	-------------------------------	--------------------

FIRE DEPT: w/conditions 5/11/10	<input checked="" type="checkbox"/> Approved <input type="checkbox"/> Denied	INSPECTION: Use Group: R-2 Type: HVAC State Gas Regs
---------------------------------------	---	--

Proposed Project Description: install 15 Embassy 45AN Gas-fired boiler	Signature: <i>[Signature]</i>	Signature: <i>[Signature]</i>
---	-------------------------------	-------------------------------

PEDESTRIAN ACTIVITIES DISTRICT (P.A.D.)		
Action: <input type="checkbox"/> Approved <input type="checkbox"/> Approved w/Conditions <input type="checkbox"/> Denied	Signature:	Date:

Permit Taken By: ldobson	Date Applied For: 05/07/2010	Zoning Approval	
-----------------------------	---------------------------------	------------------------	--

<ol style="list-style-type: none"> This permit application does not preclude the Applicant(s) from meeting applicable State and Federal Rules. Building permits do not include plumbing, septic or electrical work. Building permits are void if work is not started within six (6) months of the date of issuance. False information may invalidate a building permit and stop all work.. 	Special Zone or Reviews <input type="checkbox"/> Shoreland <input type="checkbox"/> Wetland <input type="checkbox"/> Flood Zone <input type="checkbox"/> Subdivision <input type="checkbox"/> Site Plan Maj <input type="checkbox"/> Minor <input type="checkbox"/> MM <input type="checkbox"/> Date: <i>5/10/10</i>	Zoning Appeal <input type="checkbox"/> Variance <input type="checkbox"/> Miscellaneous <input type="checkbox"/> Conditional Use <input type="checkbox"/> Interpretation <input type="checkbox"/> Approved <input type="checkbox"/> Denied Date: <i>5/10/10</i>	Historic Preservation <input checked="" type="checkbox"/> Not in District or Landmark <input type="checkbox"/> Does Not Require Review <input type="checkbox"/> Requires Review <input type="checkbox"/> Approved <input type="checkbox"/> Approved w/Conditions <input type="checkbox"/> Denied Date: <i>[Signature]</i>
---	--	--	---

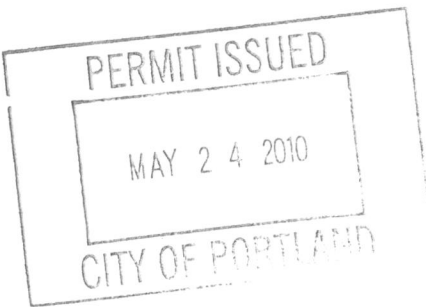

CERTIFICATION

I hereby certify that I am the owner of record of the named property, or that the proposed work is authorized by the owner of record and that I have been authorized by the owner to make this application as his authorized agent and I agree to conform to all applicable laws of this jurisdiction. In addition, if a permit for work described in the application is issued, I certify that the code official's authorized representative shall have the authority to enter all areas covered by such permit at any reasonable hour to enforce the provision of the code(s) applicable to such permit.

SIGNATURE OF APPLICANT	ADDRESS	DATE	PHONE
RESPONSIBLE PERSON IN CHARGE OF WORK, TITLE		DATE	PHONE



CITY OF PORTLAND, MAINE

Department of Building Inspections

Original Receipt

_____ 5-7 20 10 _____

Received from Darting

Location of Work 1251 Cony

Cost of Construction \$ _____ Building Fee: _____

Permit Fee \$ _____ Site Fee: _____

Certificate of Occupancy Fee: _____

Total: \$1120

Building (IL) _____ Plumbing (I5) _____ Electrical (I2) _____ Site Plan (U2) _____

Other HVAC

CBL: 186-A-3

Check #: 5025 Total Collected \$ 1120

**No work is to be started until permit issued.
Please keep original receipt for your records.**

Taken by: [Signature]

WHITE - Applicant's Copy
YELLOW - Office Copy
PINK - Permit Copy



FILL IN AND SIGN WITH INK

APPLICATION FOR PERMIT HEATING OR POWER EQUIPMENT

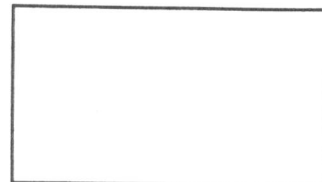

To the INSPECTOR OF BUILDINGS, PORTLAND, ME.

The undersigned hereby applies for a permit to install the following heating, cooking or power equipment in accordance with the Laws of Maine, the Building Code of the City of Portland, and the following specifications:

Location / CBL 1251 Congress St (Sunb) Use of Building Resides Date 5-7-10
 Name and address of owner of appliance Westbrook Development
Lizalharun Drive Westbrook, ME 04092
 Installer's name and address Darting Plumbing & Heat Inc 27 Vanantle Ave
Portland ME 04103 Telephone _____

Location of appliance:

- Basement
- Attic
- Floor
- Roof

Type of Fuel:

- Gas
- Oil
- Solid

Appliance Name: 15 Embassy over 4500

U.L. Approved Yes No

Will appliance be installed in accordance with the manufacture's installation instructions? Yes No

IF NO Explain: _____

The Type of License of Installer:

- Master Plumber # _____
- Solid Fuel # _____
- Oil # _____
- Gas # 473
- Other _____

Type of Chimney:

- Masonry Lined
Factory built _____

- Metal
Factory Built U.L. Listing # _____

- Direct Vent
Type _____ UL# _____

Type of Fuel Tank

- Oil
- Gas

Size of Tank _____

Number of Tanks _____

Distance from Tank to Center of Flame _____ feet.

Cost of Work: \$ 109,500.

Permit Fee: \$ 1,120

RECEIVED
 MAY - 7 2010
 Dept. of Building Inspections
 City of Portland Maine

Approved

Approved with Conditions

Fire: _____

Ele.: _____

Bldg.: _____

- See attached letter or requirement

Signature of Installer [Signature] Inspector's Signature _____ Date Approved _____

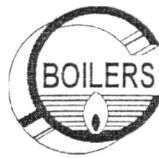

**Installation and maintenance
instructions for gas-fired condensing
hot water boilers models:
45WN, 45AN & 45WE, 45AE
(Book No. 62403466, Ed. Sep. 2008)**

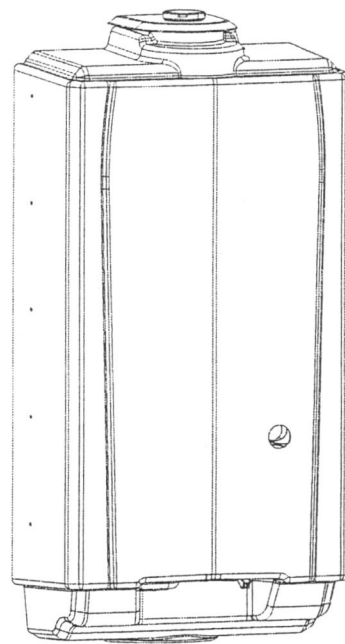
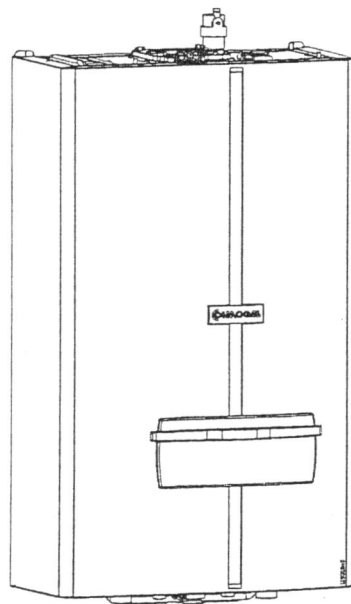

INSTALLER, THESE INSTRUCTIONS TO BE AFFIXED ADJACENT TO THE BOILER.

10 - INSTALLATION - Coaxial 60/100PP venting system

10.3 - "Coaxial 60/100PP" system: installation examples

When a coaxial vent and combustion air system is installed, figure 32, whether vertical or horizontal, it must be sloped 1/4 in/ft, (21 mm/m) towards the boiler.

CAUTION!!! Maintain the distances given in figure 33, between the vent terminal and the wall and also between the vent terminal and the ground level (snow line)

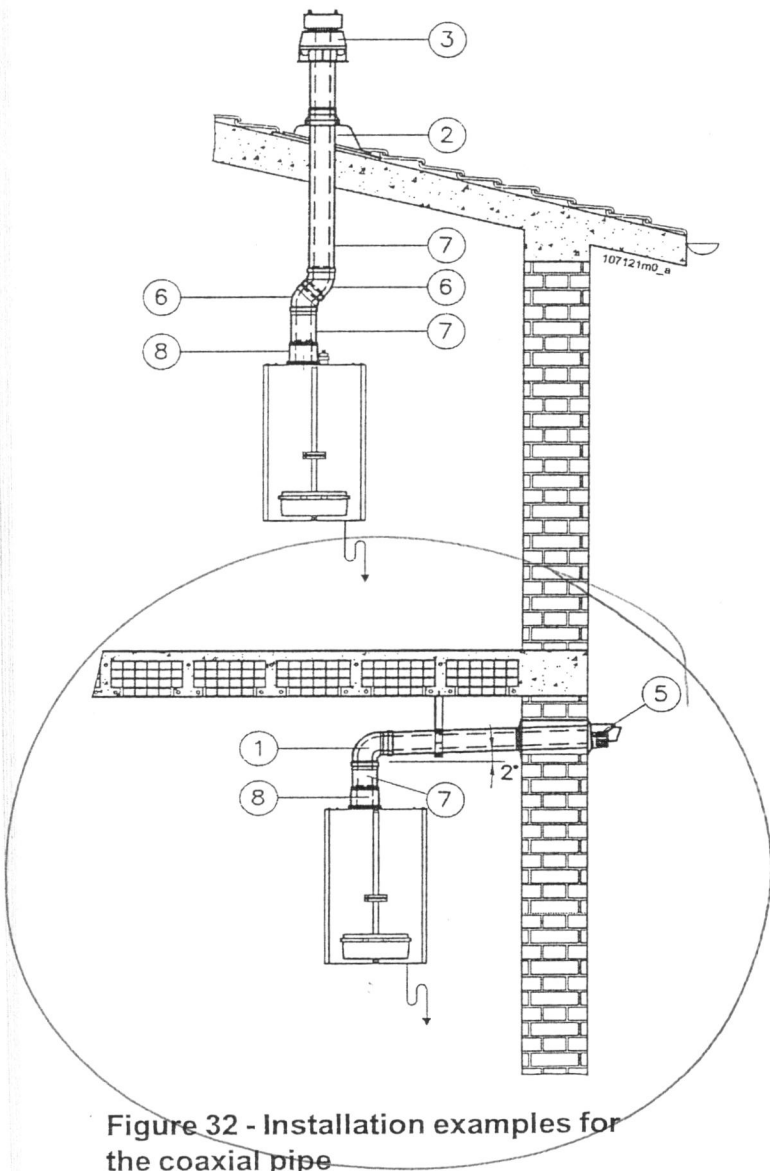

Figure 32 - Installation examples for the coaxial pipe

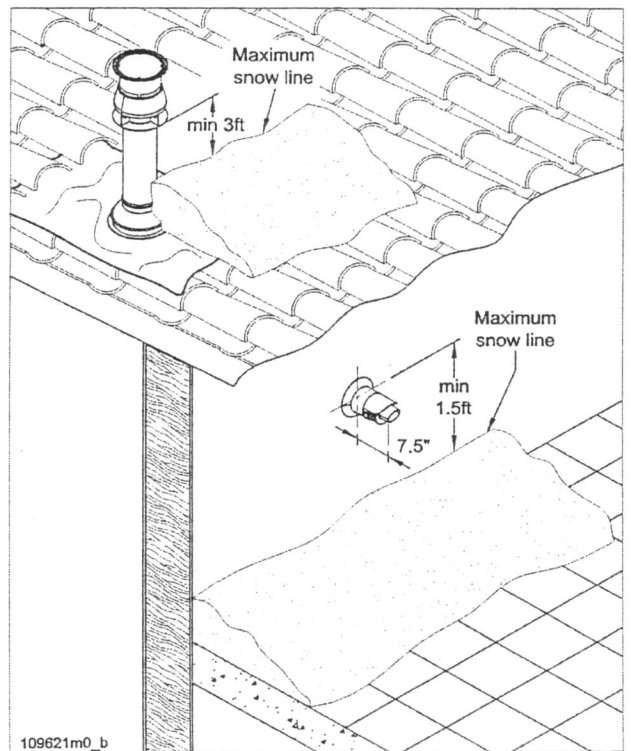

Figure 33 - Clearances for the coaxial vent terminal