

**City of Portland, Maine - Building or Use Permit Application**

389 Congress Street, 04101 Tel: (207) 874-8703, Fax: (207) 874-8716

Permit No: 08-0379	Issue Date:	CBL: 185 D015001
-----------------------	-------------	---------------------

Location of Construction: 11 WOLCOTT ST	Owner Name: MAHONEY DOROTHY I	Owner Address: 11 WOLCOTT ST	Phone:
Business Name:	Contractor Name: Jack Beaulieu Construction	Contractor Address: 45 Lincoln Road Saco	Phone 2072847073
Lessee/Buyer's Name	Phone:	Permit Type: Additions - Dwellings	Zone: R-5

Past Use: Single Family Home	Proposed Use: Single Family Home - Replace garage within existing footprint	Permit Fee: \$100.00	Cost of Work: \$8,000.00	CEO District: 3
		FIRE DEPT: <input type="checkbox"/> Approved <input type="checkbox"/> Denied	INSPECTION: Use Group: R3 Type: SB IRC 2003	

Proposed Project Description: Replace garage within existing footprint	Signature:	Signature: <i>Jm 5/19/08</i>
PEDESTRIAN ACTIVITIES DISTRICT (P.A.D.)		
Action: <input type="checkbox"/> Approved <input type="checkbox"/> Approved w/Conditions <input type="checkbox"/> Denied		
Signature:		Date:

Permit Taken By: Idobson	Date Applied For: 04/22/2008	<b>Zoning Approval</b>
-----------------------------	---------------------------------	------------------------

1. This permit application does not preclude the Applicant(s) from meeting applicable State and Federal Rules.
2. Building permits do not include plumbing, septic or electrical work.
3. Building permits are void if work is not started within six (6) months of the date of issuance. False information may invalidate a building permit and stop all work..

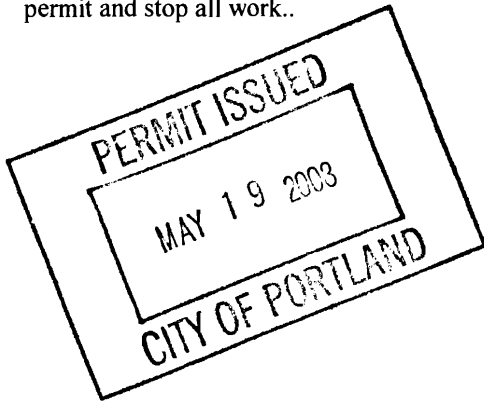

<b>Special Zone or Reviews</b> <input type="checkbox"/> Shoreland <input type="checkbox"/> Wetland <input type="checkbox"/> Flood Zone <input type="checkbox"/> Subdivision <input type="checkbox"/> Site Plan Maj <input type="checkbox"/> Minor <input type="checkbox"/> MM <input type="checkbox"/> <i>Or w/ conditions</i> Date: 5/12/08	<b>Zoning Appeal</b> <input type="checkbox"/> Variance <input type="checkbox"/> Miscellaneous <input type="checkbox"/> Conditional Use <input type="checkbox"/> Interpretation <input type="checkbox"/> Approved <input type="checkbox"/> Denied Date:	<b>Historic Preservation</b> <input checked="" type="checkbox"/> Not in District or Landmark <input type="checkbox"/> Does Not Require Review <input type="checkbox"/> Requires Review <input type="checkbox"/> Approved <input type="checkbox"/> Approved w/Conditions <input type="checkbox"/> Denied <i>ABM</i> Date:
--	---	--

**CERTIFICATION**

I hereby certify that I am the owner of record of the named property, or that the proposed work is authorized by the owner of record and that I have been authorized by the owner to make this application as his authorized agent and I agree to conform to all applicable laws of this jurisdiction. In addition, if a permit for work described in the application is issued, I certify that the code official's authorized representative shall have the authority to enter all areas covered by such permit at any reasonable hour to enforce the provision of the code(s) applicable to such permit.

SIGNATURE OF APPLICANT	ADDRESS	DATE	PHONE
RESPONSIBLE PERSON IN CHARGE OF WORK, TITLE		DATE	PHONE

# DISPLAY THIS CARD ON PRINCIPAL FRONTAGE OF WORK CITY OF PORTLAND

Please Read Application And Notes, If Any, Attached

BUILDING INSPECTION

PERMIT

**PERMIT ISSUED**  
 Permit Number: 080379  
 MAY 19 2008  
 CITY OF PORTLAND

This is to certify that MAHONEY DOROTHY I / Work Beautification Construction

has permission to Replace garage within existing footprint

AT 11 WOLCOTT ST 185 D015001

provided that the person or persons, firm or corporation accepting this permit shall comply with all of the provisions of the Statutes of Maine and of the Ordinances of the City of Portland regulating the construction, maintenance and use of buildings and structures, and of the application on file in this department.

Notification of inspection must be given and when permission is procured before this building or part thereof is altered or closed-in. 24 HOUR NOTICE IS REQUIRED.

Apply to Public Works for street line and grade if nature of work requires such information.

A certificate of occupancy must be procured by owner before this building or part thereof is occupied.

**OTHER REQUIRED APPROVALS**

- Fire Dept. \_\_\_\_\_
- Health Dept. \_\_\_\_\_
- Appeal Board \_\_\_\_\_
- Other \_\_\_\_\_  
Department Name

*Thomas M. Moulley* 5/19/08  
 Director - Building & Inspection Services

**PENALTY FOR REMOVING THIS CARD**

**City of Portland, Maine - Building or Use Permit**

389 Congress Street, 04101 Tel: (207) 874-8703, Fax: (207) 874-8716

<b>Permit No:</b> 08-0379	<b>Date Applied For:</b> 04/22/2008	<b>CBL:</b> 185 D015001
------------------------------	--	----------------------------

<b>Location of Construction:</b> 11 WOLCOTT ST	<b>Owner Name:</b> MAHONEY DOROTHY I	<b>Owner Address:</b> 11 WOLCOTT ST	<b>Phone:</b>
<b>Business Name:</b>	<b>Contractor Name:</b> Jack Beaulieu Construction	<b>Contractor Address:</b> 45 Lincoln Road Saco	<b>Phone</b> (207) 284-7073
<b>Lessee/Buyer's Name</b>	<b>Phone:</b>	<b>Permit Type:</b> Additions - Dwellings	

<b>Proposed Use:</b> Single Family Home - Demo & replace garage & within existing footprint	<b>Proposed Project Description:</b> Demo & replace garage within existing footprint
--	---

**Dept:** Zoning      **Status:** Approved with Conditions      **Reviewer:** Ann Machado      **Approval Date:** 05/12/2008

**Note:** **Ok to Issue:**

- 1) This property shall remain a single family dwelling. Any change of use shall require a separate permit application for review and approval.
- 2) This permit is being approved on the basis of plans submitted. Any deviations shall require a separate approval before starting that work.
- 3) Your present structure is legally nonconforming as to setbacks. If you are to demolish this structure on your own volition, you will only have one (1) year to replace it in the same footprint (no expansions), with the same height, and same use. Any changes to any of the above shall require that this structure meet the current zoning standards. The one (1) year starts at the time of removal. It shall be the owner's responsibility to contact the Code Enforcement Officer and notify them of that specific date.

**Dept:** Building      **Status:** Approved with Conditions      **Reviewer:** Tom Markley      **Approval Date:** 05/19/2008

**Note:** **Ok to Issue:**

- 1) Separate permits are required for any electrical, plumbing, or HVAC systems. Separate plans may need to be submitted for approval as a part of this process.
- 2) Application approval based upon information provided by applicant. Any deviation from approved plans requires separate review and approval prior to work.

**Comments:**

5/5/2008-amachado: Spoke to Jack Beaulieu, contractor. Need demolition call list & requirements. He said that he would call the owner,s son.

5/12/2008-amachado: Received demo call list & notice to adjoining property owners.

5/12/2008-amachado: Gave permit to Lannie to schedule the predemolition inspection.

**BUILDING PERMIT INSPECTION PROCEDURES**

**Please call 874-8703 or 874-8693 (ONLY )**

**to schedule your inspections as agreed upon**

**Permits expire in 6 months, if the project is not started or ceases for 6 months.**

The Owner or their designee is required to notify the inspections office for the following inspections and provide adequate notice. Notice must be called in 48-72 hours in advance in order to schedule an inspection:

**By initializing at each inspection time, you are agreeing that you understand the inspection procedure and additional fees from a "Stop Work Order" and "Stop Work Order Release" will be incurred if the procedure is not followed as stated below.**

**A Pre-construction Meeting will take place upon receipt of your building permit.**

  X   **Footing/Building Location Inspection: Prior to pouring concrete or setting precast piers**

  X   **Framing/Rough Plumbing/Electrical: Prior to Any Insulating or drywalling**

  X   **Final inspection required at completion of work.**

Certificate of Occupancy is not required for certain projects. Your inspector can advise you if your project requires a Certificate of Occupancy. All projects DO require a final inspection.

**If any of the inspections do not occur, the project cannot go on to the next phase, REGARDLESS OF THE NOTICE OR CIRCUMSTANCES.**

**CERIFICATE OF OCCUPANICES MUST BE ISSUED AND PAID FOR, BEFORE THE SPACE MAY BE OCCUPIED.**

\_\_\_\_\_  
Signature of Applicant/Designee

*Thomas H. Mahaley*  
\_\_\_\_\_  
Signature of Inspections Official

\_\_\_\_\_  
Date

*5/19/08*  
\_\_\_\_\_  
Date

**City of Portland, Maine - Building or Use Permit**

389 Congress Street, 04101 Tel: (207) 874-8703, Fax: (207) 874-8716

<b>Permit No:</b> 08-0379	<b>Date Applied For:</b> 04/22/2008	<b>CBL:</b> 185 D015001
------------------------------	--	----------------------------

<b>Location of Construction:</b> 11 WOLCOTT ST	<b>Owner Name:</b> MAHONEY DOROTHY I	<b>Owner Address:</b> 11 WOLCOTT ST	<b>Phone:</b>
<b>Business Name:</b>	<b>Contractor Name:</b> Jack Beaulieu Construction	<b>Contractor Address:</b> 45 Lincoln Road Saco	<b>Phone</b> (207) 284-7073
<b>Lessee/Buyer's Name</b>	<b>Phone:</b>	<b>Permit Type:</b> Additions - Dwellings	

<b>Proposed Use:</b> Single Family Home - Demo & replace garage & within existing footprint	<b>Proposed Project Description:</b> Demo & replace garage within existing footprint
--	---

<b>Dept:</b> Zoning	<b>Status:</b> Approved with Conditions	<b>Reviewer:</b> Ann Machado	<b>Approval Date:</b> 05/12/2008
<b>Note:</b>			<b>Ok to Issue:</b> <input checked="" type="checkbox"/>
<p>1) This property shall remain a single family dwelling. Any change of use shall require a separate permit application for review and approval.</p> <p>2) This permit is being approved on the basis of plans submitted. Any deviations shall require a separate approval before starting that work.</p> <p>3) Your present structure is legally nonconforming as to setbacks. If you are to demolish this structure on your own volition, you will only have one (1) year to replace it in the same footprint (no expansions), with the same height, and same use. Any changes to any of the above shall require that this structure meet the current zoning standards. The one (1) year starts at the time of removal. It shall be the owner's responsibility to contact the Code Enforcement Officer and notify them of that specific date.</p>			
<b>Dept:</b> Building	<b>Status:</b> Pending	<b>Reviewer:</b>	<b>Approval Date:</b>
<b>Note:</b>			<b>Ok to Issue:</b> <input type="checkbox"/>

<b>Comments:</b>
5/5/2008-amachado: Spoke to Jack Beaulieu, contractor. Need demolition call list & requirements. He said that he would call the owner,s son.
5/12/2008-amachado: Received demo call list & notice to adjoining property owners.
5/12/2008-amachado: Gave permit to Lannie to schedule the predemolition inspection.



# General Building Permit Application

If you or the property owner owes real property taxes or user charges on any property within the City of Portland, Maine, no permits of any kind are accepted.

Location/Address of Construction: <u>ST PORT.</u>	
Total Square Footage of Construction: <u>324</u> of Lot: <u>G</u>	
Tax Assessor's Chart, Block# <u>Chart#</u> Block# <u>Block#</u>	Lessee or Buyer* <u>ney</u> Telephone: <u>01103</u>
Lessee/DBA (If Applicable) _____	Cost Of Work: \$ <u>8000.00</u> C of O Fee: \$ _____ Total Fee: \$ _____
Current legal use (i.e. single family) <u>Single family home</u> If vacant, what was the previous use? _____ Proposed Specific use: <u>Replace Garage</u> Is property part of a subdivision? _____ If yes, please name _____ Project description: <u>Replace garage within existing footprint</u>	
Contractor's name: <u>JACK BEAUFREU CONST</u> Address: <u>45 LINCOLN RD</u> City, State & Zip: <u>SACO ME 04072</u> Telephone: <u>284 7073</u> Who should we contact when the permit is ready: <u>OWNER Greg. Hoyt</u> Telephone: <u>415-1215</u> Mailing address: <u>11 WOLCOTT ST PORT.</u>	

**Please submit all of the information outlined on the applicable Checklist. Failure to do so will result in the automatic denial of your permit.**

In order to be sure the City fully understands the full scope of the project, the Planning and Development Department may request additional information prior to the issuance of a permit. For further information or to download copies of this form and other applications visit the Inspections Division on-line at [www.portlandmaine.gov](http://www.portlandmaine.gov), or stop by the Inspections Division office, room 315 City Hall or call 874-8703.

I hereby certify that I am the Owner of record of the named property, or that the owner of record authorizes the proposed work and that I have been authorized by the owner to make this application as his/her authorized agent. I agree to conform to all applicable laws of this jurisdiction. In addition, if a permit for work described in this application is issued, I certify that the Code Official's authorized representative shall have the authority to enter all areas covered by this permit at any reasonable hour to enforce the provisions of the codes applicable to this permit.

Signature: Dorothy J. Mahoney Date: April 21, 2008

**This is not a permit; you may not commence ANY work until the permit is issued.**



Fax 874-8716

# Demolition Call List & Requirements

Site Address: 11 Wolcott St. Port. me.

Owner: Dorothy Mahoney

Structure Type: Garage

Contractor: Jack Construction

## Utility Approvals

Central Maine Power

Number

1-800-750-4000

Contact Name/Date

Shailah (would not give last name)

Northern Utilities

797-8002 ext 6241

mark allen

Portland Water District

761-8310

walter whitney

Dig Safe Ref. 2008 200 1781

1-888-344-7233

Betty (would not give last name)

After calling Dig Safe, you must wait 72 business hours before digging can begin.

DPW/ Traffic Division (L. Cote)

874-8891

maynard Spague

DPW/ Sealed Drain Permit (C. Merritt)

874-8822

Carol Merritt

Historic Preservation

874-8726

Deb Andrews

Fire Dispatcher

874-8576

Brad Williams

## Additional Requirements

- 1)  Written Notice to Adjoining Owners
- 2)  A Photo of the Structure(s) to be demolished
- 3) Certification from an asbestos abatement company
- 4) Provide a copy of the **ISSUED** Sealed Drain Permit from the Public Works Department.

DEP – Environmental (Augusta)

287-2651

Sandy moody

U.S. EPA Region 1 – No Phone call required. Just mail copy of State notification to:

Demo / Reno Clerk  
US EPA Region I (SEA)  
JFK Federal Building  
Boston, MA 02203

I have contacted all of the necessary companies/departments as indicated above and attached all required documentation.

Signed: Dorothy J. Mahoney

Date: May 12, 2008

5/12/08

To Whom it may concern,  
Mrs. Dorothy Maloney will be demolishing  
her old garage and replacing it with a new one  
exactly like the old one. She resides at 11  
Walcott St. If you have any question concerning  
this, please call me.

Gregory J. Hoyt

2078925221

(Son Andrew)

MAY 12 2008



11 WOLCOTT ST PORTLAND ME

DEMO GARAGE →  
BUILD NEW  
ON EXISTING  
SLAB  
← 30' TO ~~GARAGE~~  
GARAGE

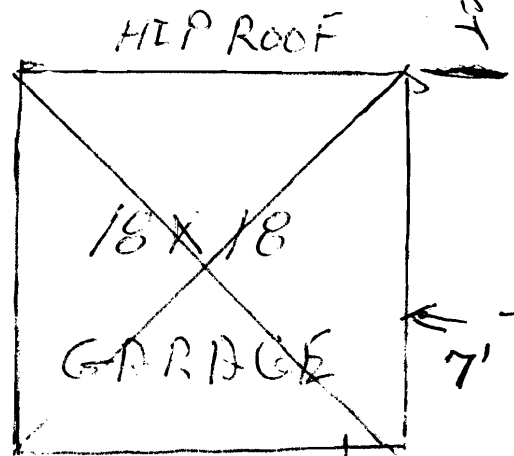

← 95' TREE LINE →

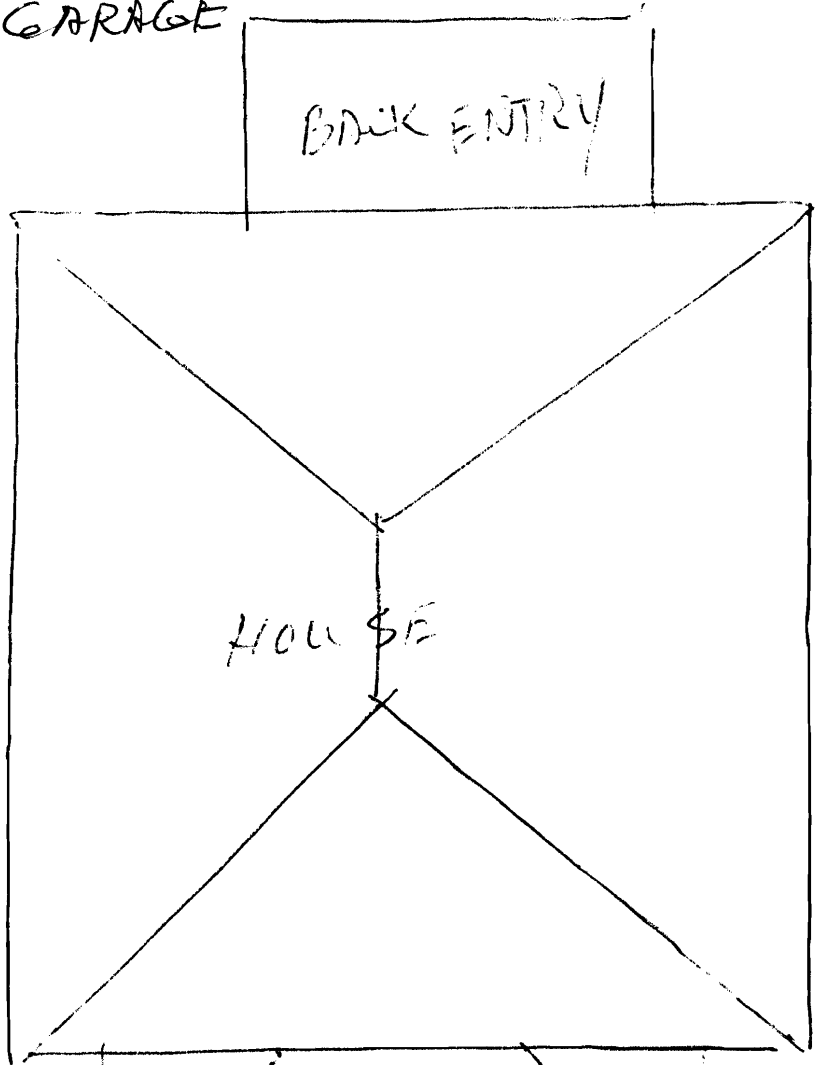

← 55' →

FENCE



NEW GARAGE 11 WOLCOTT ST PORT,  
18'

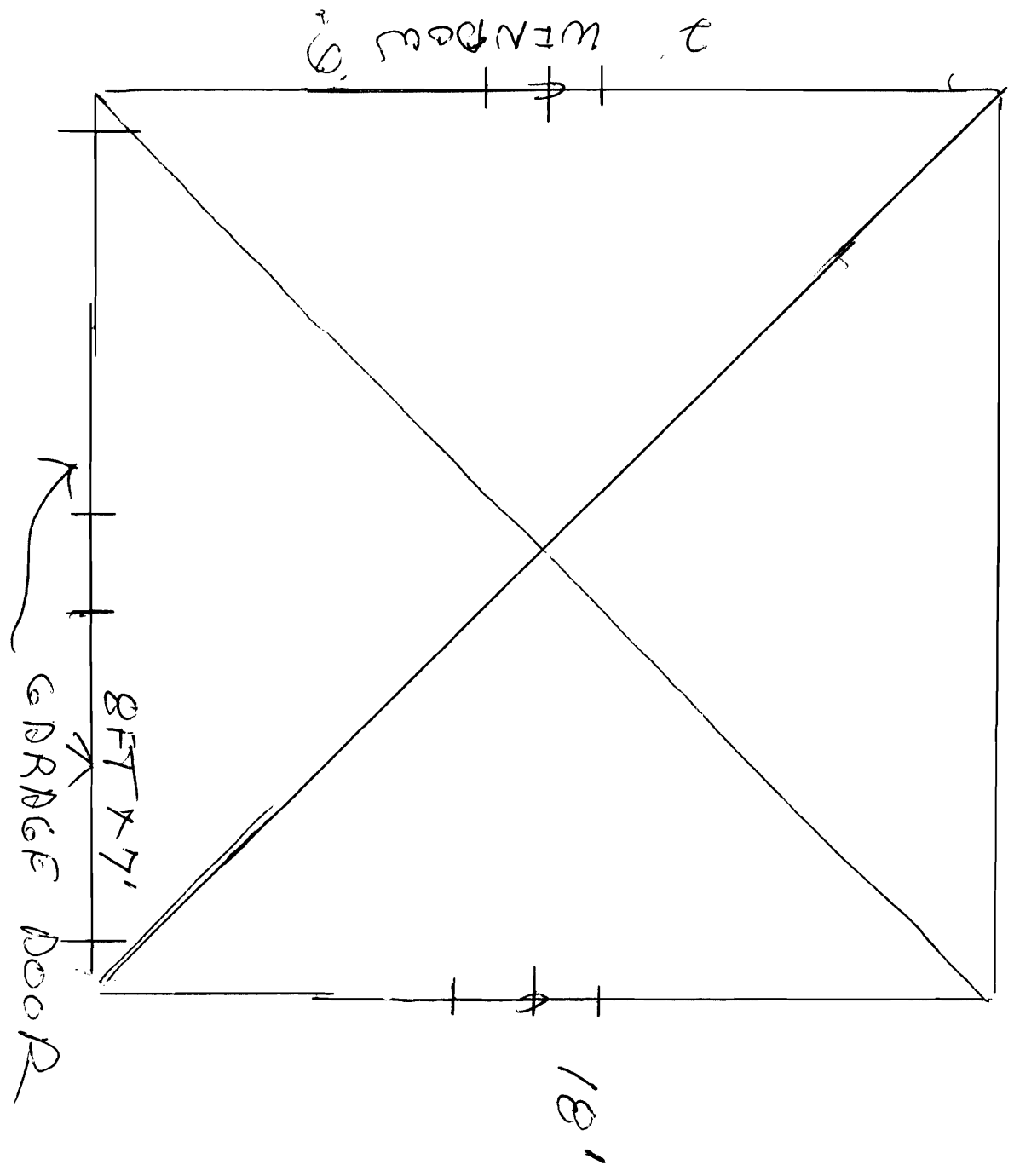

NEW GARAGE CROSS SECTION

# 2 PORTLAND 11 WOLCOTT ST

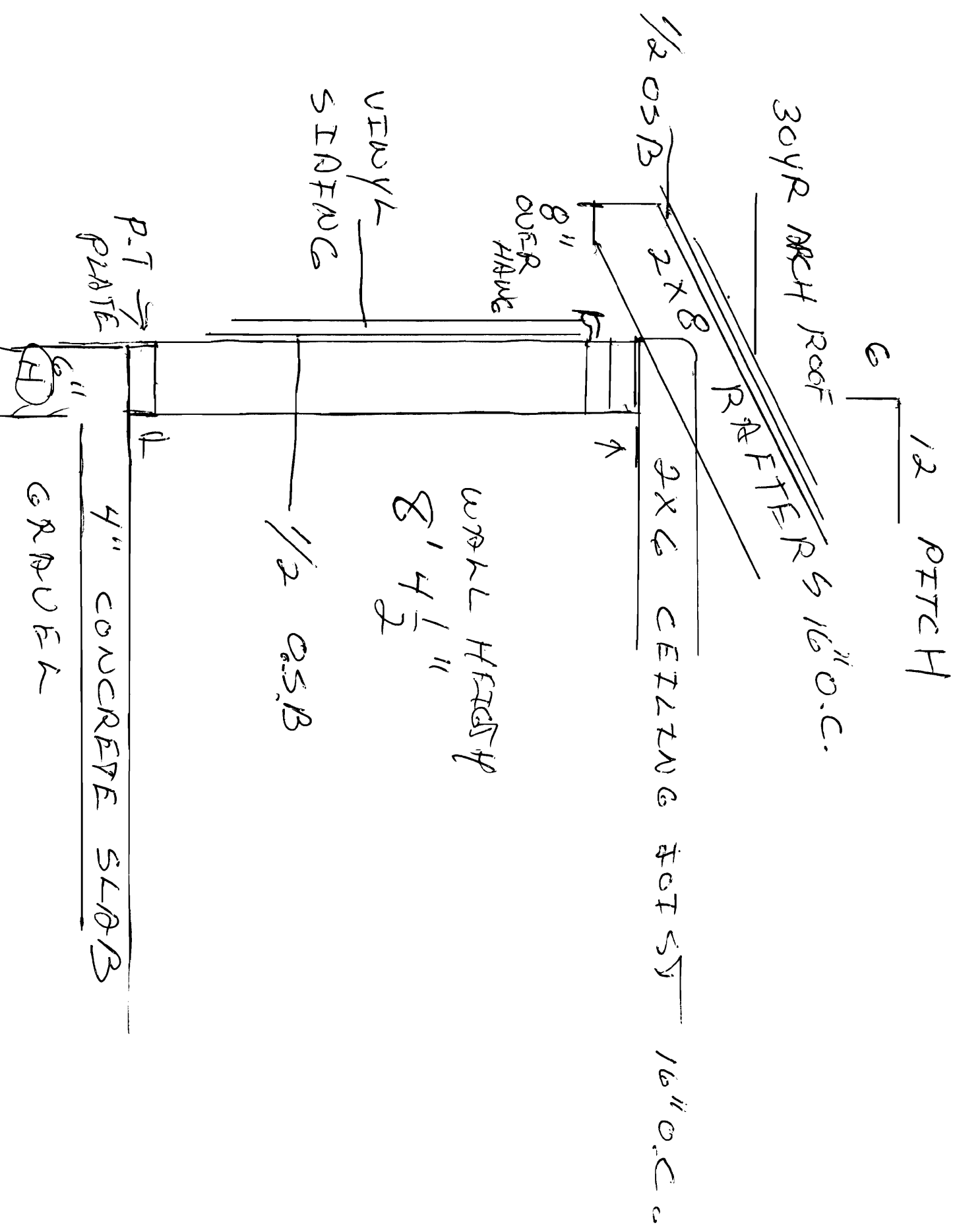



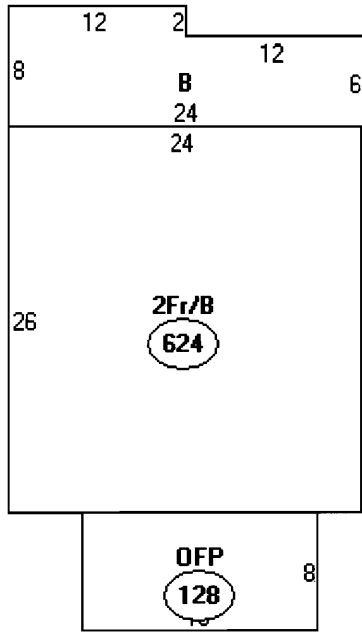

Descriptor/Area

A: 2Fr/B  
624 sqft

B: EP  
168 sqft

C: OFP  
128 sqft

**BUILDING PERMIT INSPECTION PROCEDURES**

Please call 874-8703 or 874-8693 (ONLY)

to schedule your inspections as agreed upon

Permits expire in 6 months, if the project is not started or ceases for 6 months.

The Owner or their designee is required to notify the inspections office for the following inspections and provide adequate notice. Notice must be called in 48-72 hours in advance in order to schedule an inspection:

By initializing at each inspection time, you are agreeing that you understand the inspection procedure and additional fees from a "Stop Work Order" and "Stop Work Order Release" will be incurred if the procedure is not followed as stated below.

A Pre-construction Meeting will take place upon receipt of your building permit.

- Footing/Building Location Inspection: Prior to pouring concrete or setting precast piers
- Framing/Rough Plumbing/Electrical: Prior to Any Insulating or drywalling
- Final inspection required at completion of work.

Certificate of Occupancy is not required for certain projects. Your inspector can advise you if your project requires a Certificate of Occupancy. All projects DO require a final inspection.

If any of the inspections do not occur, the project cannot go on to the next phase, REGARDLESS OF THE NOTICE OR CIRCUMSTANCES.

**CERIFICATE OF OCCUPANICES MUST BE ISSUED AND PAID FOR, BEFORE THE SPACE MAY BE OCCUPIED.**

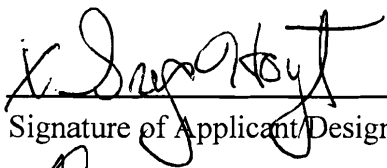
  
Signature of Applicant/Designee

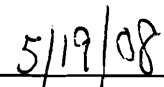
  
Date

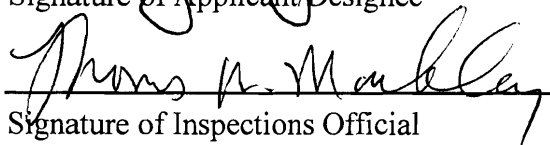
  
Signature of Inspections Official

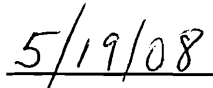
  
Date