

DISPLAY THIS CARD ON PRINCIPAL FRONTAGE OF WORK CITY OF PORTLAND

BUILDING INSPECTION

Permit Number: 031163

Please Read Application And Notes, If Any, Attached

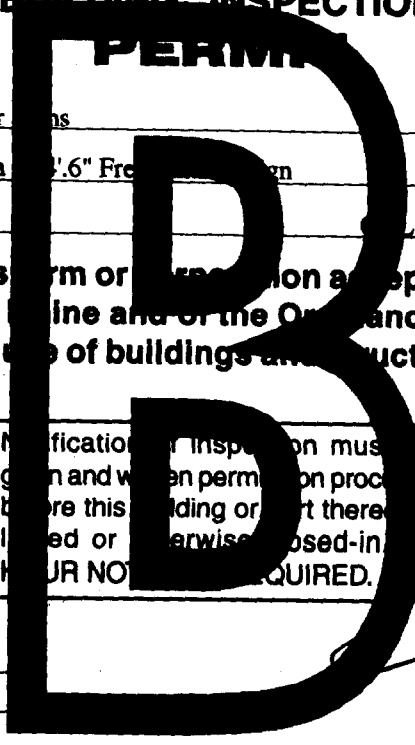

This is to certify that St Ansgar Evangelical/Burr ns

has permission to Attach a 4'x3'.6" Sign and a 4'.6" Fre sign

AT 5 Columbia Rd 184 C001001

provided that the person or persons who accept this permit shall comply with all of the provisions of the Statutes of this State and of the Ordinances of the City of Portland regulating the construction, maintenance and use of buildings and structures, and of the application on file in this department.

Apply to Public Works for street line and grade if nature of work requires such information.

Notification of inspection must be given and when permission is procured before this building or part thereof is occupied or otherwise used-in-accordance with the provisions of the Code. YOUR NOTICE IS REQUIRED.

A certificate of occupancy must be procured by owner before this building or part thereof is occupied.

OTHER REQUIRED APPROVALS

Fire Dept. _____
Health Dept. _____
Appeal Board _____
Other _____
Department Name _____

[Handwritten Signature]
Director, Building & Inspection Services

PENALTY FOR REMOVING THIS CARD

City of Portland, Maine - Building or Use Permit Application

389 Congress Street, 04101 Tel: (207) 874-8703, Fax: (207) 874-8716

Permit No: 03-1163	Issue Date:	CBL: 184 C001001
-----------------------	-------------	---------------------

Location of Construction: 5 Columbia Rd	Owner Name: St Ansgar Evangelical	Owner Address: 515 Woodford St	Phone: 774-8740
Business Name:	Contractor Name: Burr Signs	Contractor Address: 10 Buttonwood St. So. Portland	Phone: 2077991183
Lessee/Buyer's Name	Phone:	Permit Type: Signs - Permanent	Zone: B1

Past Use: St. Ansgar Lutheran Church/Commercial	Proposed Use: St. Ansgar Lutheran Church/Commercial	Permit Fee: \$132.40	Cost of Work: \$132.40	CEO District: 3
--	--	-------------------------	---------------------------	--------------------

FIRE DEPT: <input checked="" type="checkbox"/> Approved <input type="checkbox"/> Denied <i>N/A</i>	INSPECTION: Use Group: <i>U</i> Type: <i>Sign</i> <i>BOCA 99</i>
Signature: <i>[Signature]</i>	Signature: <i>[Signature]</i>

Proposed Project Description:
Attach a 4'x3'.6" Sign and a 8'x4'.6" Freestanding Sign

PEDESTRIAN ACTIVITIES DISTRICT (P.A.D.)		
Action:	<input type="checkbox"/> Approved	<input type="checkbox"/> Approved w/Conditions
Signature:	Date:	

Permit Taken By: gad	Date Applied For: 09/23/2003	Zoning Approval	
-------------------------	---------------------------------	------------------------	--

<ol style="list-style-type: none"> This permit application does not preclude the Applicant(s) from meeting applicable State and Federal Rules. Building permits do not include plumbing, septic or electrical work. Building permits are void if work is not started within six (6) months of the date of issuance. False information may invalidate a building permit and stop all work.. 	Special Zone or Reviews <input type="checkbox"/> Shoreland <input type="checkbox"/> Wetland <input type="checkbox"/> Flood Zone <input type="checkbox"/> Subdivision <input type="checkbox"/> Site Plan Maj <input type="checkbox"/> Minor <input type="checkbox"/> M/M <input type="checkbox"/> Date: <i>9/25/03</i>	Zoning Appeal <input checked="" type="checkbox"/> Variance <input type="checkbox"/> Miscellaneous <input type="checkbox"/> Conditional Use <input type="checkbox"/> Interpretation <input type="checkbox"/> Approved <input type="checkbox"/> Denied Date:	Historic Preservation <input checked="" type="checkbox"/> Not in District or Landmark <input type="checkbox"/> Does Not Require Review <input type="checkbox"/> Requires Review <input type="checkbox"/> Approved <input type="checkbox"/> Approved w/Conditions <input type="checkbox"/> Denied Date:
	<i>old free standing sign to be removed</i>		

CERTIFICATION

I hereby certify that I am the owner of record of the named property, or that the proposed work is authorized by the owner of record and that I have been authorized by the owner to make this application as his authorized agent and I agree to conform to all applicable laws of this jurisdiction. In addition, if a permit for work described in the application is issued, I certify that the code official's authorized representative shall have the authority to enter all areas covered by such permit at any reasonable hour to enforce the provision of the code(s) applicable to such permit.

SIGNATURE OF APPLICANT	ADDRESS	DATE	PHONE
RESPONSIBLE PERSON IN CHARGE OF WORK, TITLE		DATE	PHONE

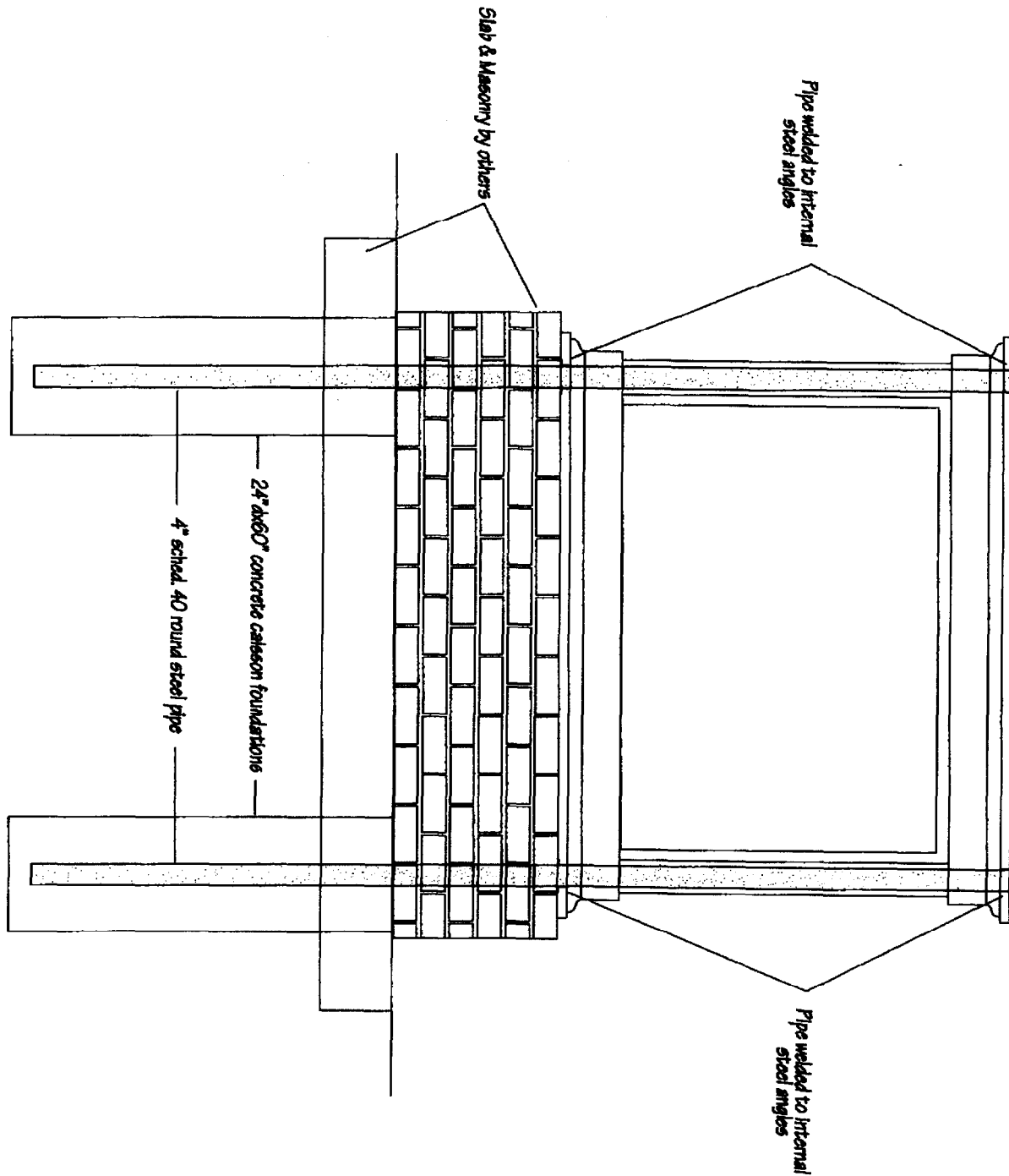

THIS DESIGN IS THE EXCLUSIVE PROPERTY OF BURR SIGNS. ALL PRODUCTION AND REPRODUCTION RIGHTS ARE RESERVED BY US. THIS PRINT HAS BEEN DESIGNED FOR YOUR PERSONAL USE. IT MAY NOT BE SUBMITTED, USED OR EXHIBITED OUTSIDE OF YOUR COMPANY OR ORGANIZATION WITHOUT THE EXPRESSED WRITTEN PERMISSION OF BURR SIGNS. © Copyright	CLIENT ST. ANSGAR LOCATION PORTLAND, ME SALES PERSON R. BURR DRAWN BY R. BURR SCALE N.T.S. DATE 09/25/03 APPROVED SIGNATURE DRAWING NO. St Ansgar's S.c.d.1 DATE 10/17/03	BURR SIGNS <small>10 BURNINGWOOD ST. ST. ANSGAR, ME 04088 PH: 207-799-1324 FAX: 207-799-1324</small>
--	--	--



10 Buttonwood St.
South Portland, ME 04106

Recipient: Tammy Munson

Sent By: Randy Burr

Company: City of Portland

Company: Burr Signs

Fax Number: 8748716

Fax Number: 2077991324

Voice Number:

Voice Number: 2077991183

Date: 10/17/03

Time: 4:34:55 PM

Total No. Pages: 2

Subject:

Message:

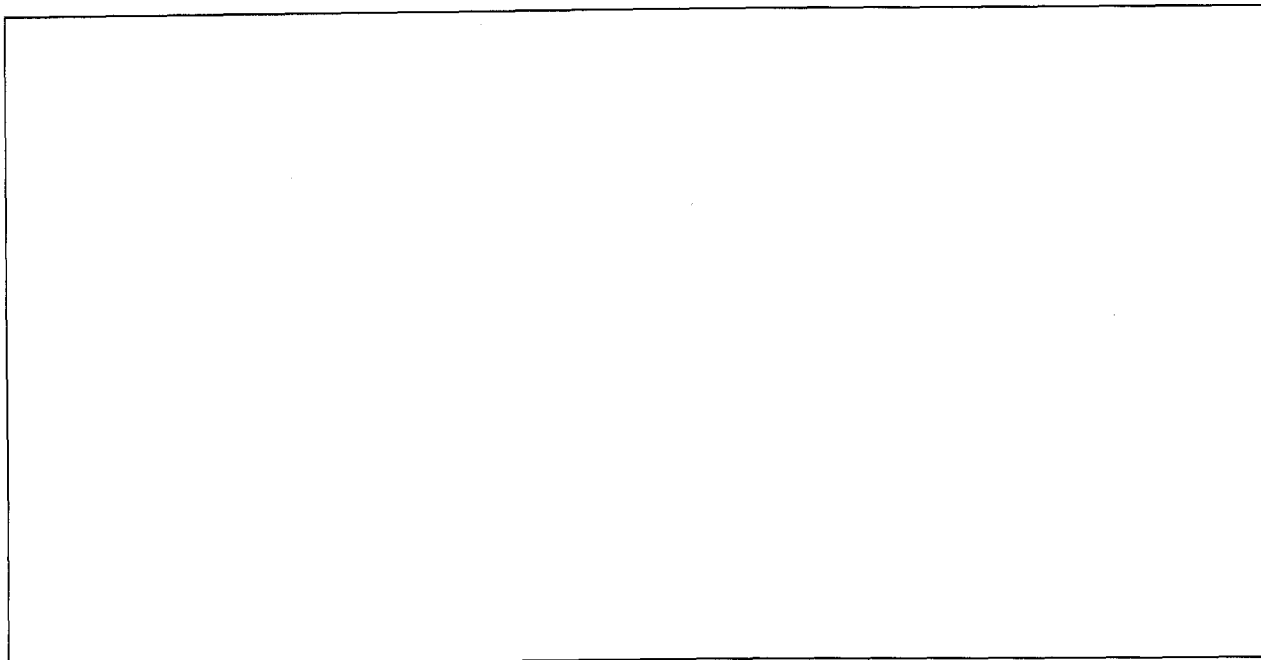

03-1163

Signage/Awning Permit Application

If you or the property owner owes real estate or personal property taxes or user charges on any property within the City, payment arrangements must be made before permits of any kind are accepted.

5-13 Columbia Road + 509-523

Location/Address of Construction: <u>515 WOODFORDS ST. ←</u>		
Total Square Footage of Proposed Structure <u>36' SQ FT SIGNAGE / 58' SQ FT Structure</u>	Square Footage of Lot <u>25 200' SQ FT</u>	
Tax Assessor's Chart, Block & Lot Chart# <u>184</u> Block# <u>8</u> Lot# <u>001</u>	Owner: <u>St. ANSGAR Church</u>	Telephone: <u>774-8740</u>
Lessee/Buyer's Name (If Applicable)	Applicant name, address & telephone: <u>St. ANSGAR LUTHERAN Church</u> <u>515 WOODFORDS ST.</u> <u>PORTLAND, MAINE 04163</u> <u>774-8740</u>	Total s.f. of signage x <u>102.40</u> \$1.00 per s.f. plus \$30.00 = Total Fee: <u>\$ 6.00</u> @ 132.40 Awning Fee = Cost Of Work: \$ Total Fee: \$ <u>102.40</u>
Current use: <u>CHURCH</u>		
If the location is currently vacant, what was prior use: <u>TOTAL of 51.20 SQ FT</u>		
Approximately how long has it been vacant: <u>= 14.4 SQ FT</u>		
Proposed use: <u>one 4' x 3'6" attached sign</u>		
Project description: <u>one 8' x 4'6" freestanding on posts</u>		
Contractor's name, address & telephone:		
Who should we contact when the permit is ready: <u>Burr Signs</u>		102.40 SF Fee
Mailing address: <u>10 Buttonwood St.</u> <u>So. Portland, Me 04106</u>		30.00 Bldg Fee
		<u>\$ 132.40</u>
We will contact you by phone when the permit is ready. You must come in and pick up the permit and review the requirements before starting any work, with a Plan Reviewer. A stop work order will be issued and a \$100.00 fee if any work starts before the permit is picked up. PHONE: <u>799-1183</u>		

IF THE REQUIRED INFORMATION IS NOT INCLUDED IN THE SUBMISSIONS THE PERMIT WILL BE AUTOMATICALLY DENIED AT THE DISCRETION OF THE BUILDING/PLANNING DEPARTMENT. WE MAY REQUIRE ADDITIONAL INFORMATION IN ORDER TO APPROVE THIS PERMIT.

I hereby certify that I am the Owner of record of the named property, or that the owner of record authorizes the proposed work and that I have been authorized by the owner to make this application as his/her authorized agent. I agree to conform to all applicable laws of this jurisdiction. In addition, if a permit for work described in this application is issued, I certify that the Code Official's authorized representative shall have the authority to enter all areas covered by this permit at any reasonable hour to enforce the provisions of the codes applicable to this permit.

Signature of applicant: <u>Fran Lorange</u>	Date: <u>9-23-03</u>
---	----------------------

This is NOT a permit, you may not commence ANY work until the permit is issued.

SIGNAGE/AWNING PRE-APPLICATION QUESTIONNAIRE

PLEASE ANSWER ALL QUESTIONS

ADDRESS: 515 WOODFORDS ST, PORTLAND ZONE: R5

CBL: _____

SINGLE TENANT LOT? YES NO _____ MULTI TENANT LOT? YES _____ NO _____

MORE THAN ONE SIGN TOTAL WITH PROPOSED SIGN? YES _____ NO _____

INFORMATION ON PROPOSED SIGN(S):

FREESTANDING (e.g., pole) SIGN? YES NO _____ DIMENSIONS PROPOSED: SIGN 8'x4'6" / STRUCTURE 10'x5'10"

BLDG. WALL SIGN? (attached to bldg) YES NO _____ DIMENSIONS PROPOSED: 4' x 3'6"

INFORMATION ON ALREADY EXISTING AND PERMITTED SIGN(S):

FREESTANDING (e.g., pole) SIGN? YES NO _____ DIMENSIONS: 6' x 4' ← Old Freestanding

BLDG. WALL SIGN(attached to bldg) ? YES _____ NO DIMENSIONS: Sign removed

AWNING? YES _____ NO DIMENSIONS: AS of 9/25/03

LOT FRONTAGE (FEET): 120' x 210'

TENANT/ALLOCATED BUILDING SPACE FRONTAGE (FEET): _____

AWNING YES _____ NO IS AWNING BACKLIT? YES _____ NO _____

HEIGHT OF AWNING: _____ LENGTH OF AWNING: _____ DEPTH: _____

IS THERE ANY COMMUNICATION, MESSAGE, TRADEMARK OR SYMBOL ON IT? YES _____ NO _____

IF YES, TOTAL S.F. OF PANELS WITH COMMUNICATIONS/MESSAGE/TRADEMARK/SYMBOL? _____ s.f.

A SITE SKETCH AND BUILDING SKETCH SHOWING EXACTLY WHERE EXISTING AND NEW SIGNAGE IS LOCATED MUST BE PROVIDED. SKETCHES AND/OR PICTURES OF PROPOSED SIGNAGE ARE ALSO REQUIRED.

SIGNATURE OF APPLICANT: From Cooney DATE: 9-23-03

***** FOR OFFICE USE ONLY *****

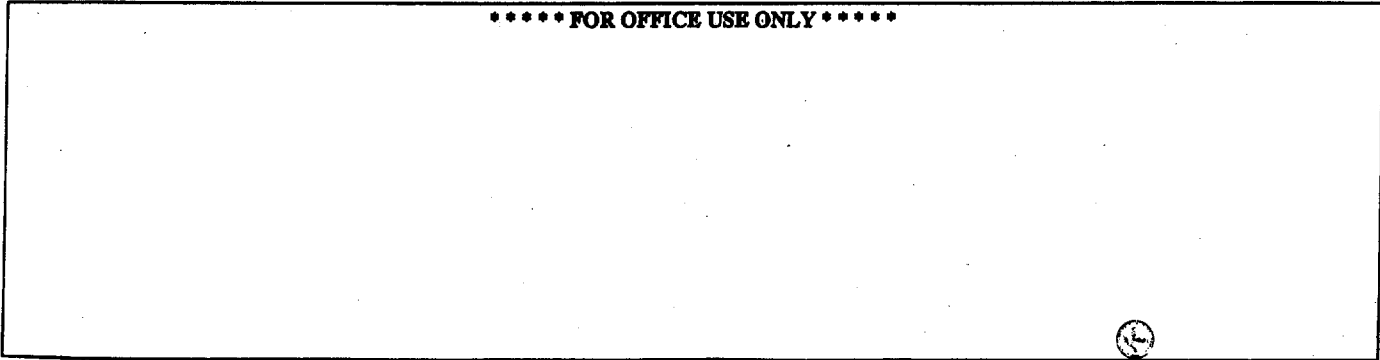

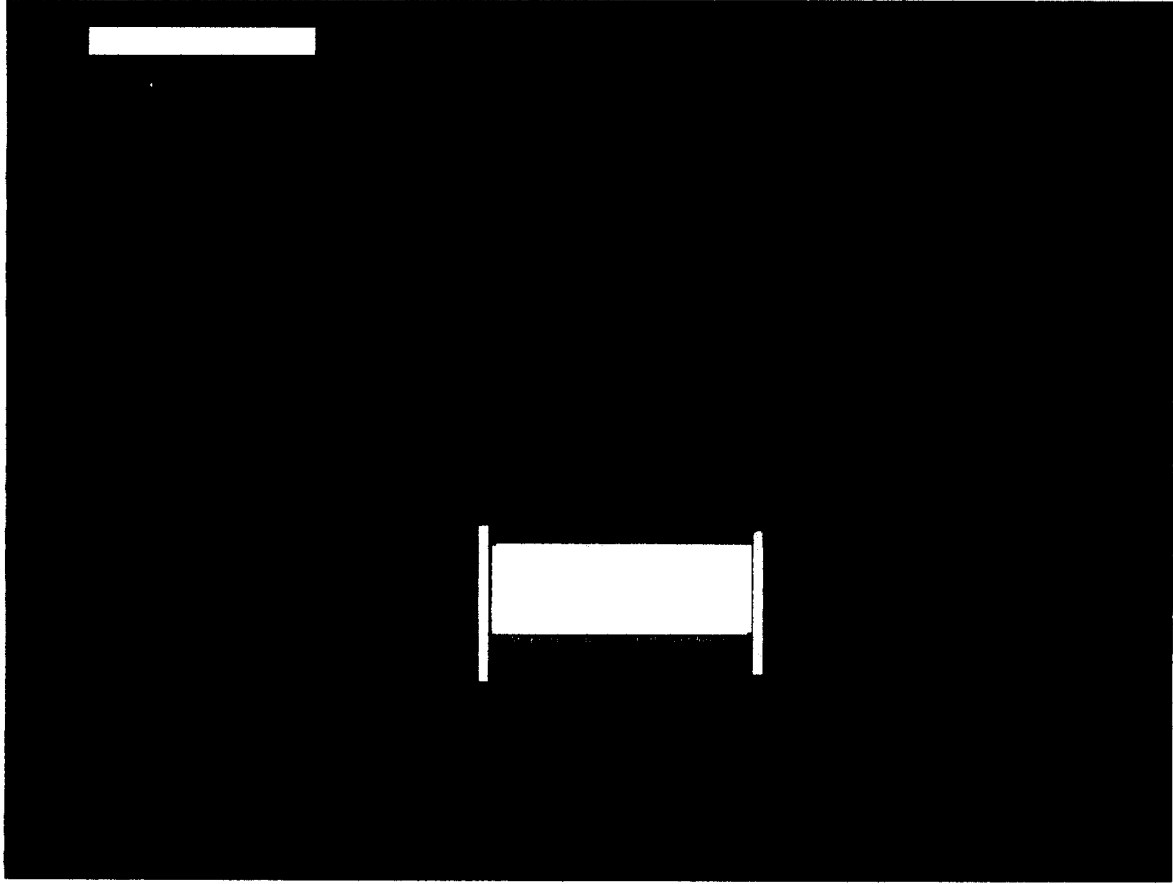

Existing Sign

NOT to SCALE

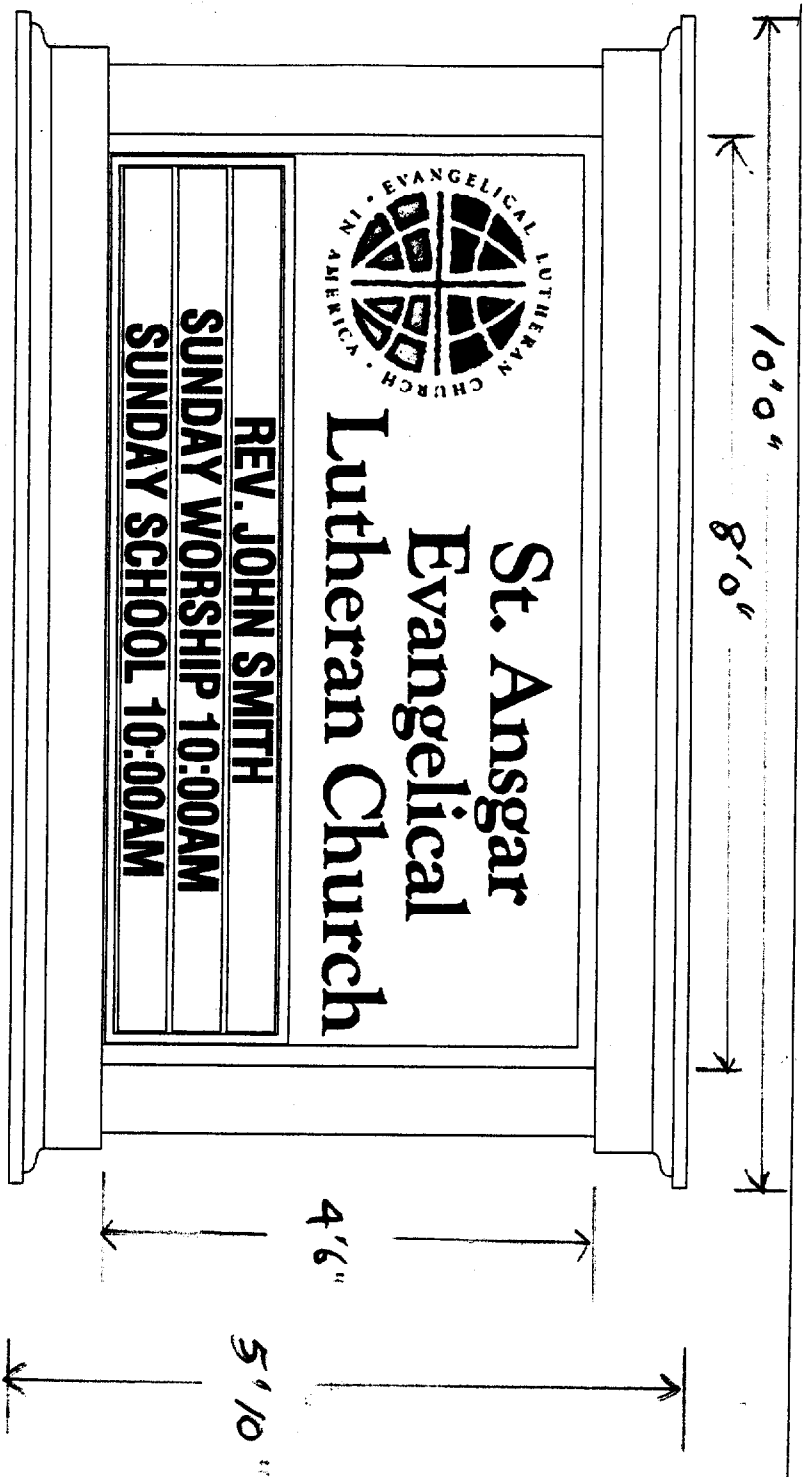

with no visible fasteners
 Aluminum
 vinyl
 the millwork
 schedule 40 round steel pipes
 pipes w/HO ballast recessed in top soffitt
 fasteners with locking clear Lexan face cover

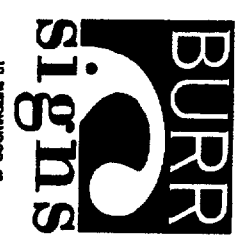

10 BIRCHWOOD ST.
 ST. PORTLAND, ME 04106
 PH: 207-799-1183 FX: 207-799-1324

THIS DESIGN IS THE EXCLUSIVE PROPERTY OF BURR SIGNS. ALL PRODUCTION AND REPRODUCTION RIGHTS ARE RESERVED BY US.

THIS PRINT HAS BEEN DESIGNED FOR YOUR PERSONAL USE. IT MAY NOT BE SUBMITTED, USED OR EXHIBITED OUTSIDE OF YOUR COMPANY OR ORGANIZATION WITHOUT THE EXPRESSED WRITTEN PERMISSION OF BURR SIGNS.

● Copyright

CLIENT
 ST. ANSGAR

LOCATION
 PORTLAND, ME

SALES PERSON
 R. BURR

DRAWN BY
 R. BURR

SCALE
 1" = 20"

DATE
 02/13/03

ACCEPTANCE SIGNATURE

DWG

DRAWING NO.
 St Ansgar 3.cdl

COLORS SHOWN HERE MAY NOT REPRESENT ACTUAL COLORS. COLOR MATCH NUMBERS MAY BE REQUIRED.



Sign Elevation

MATERIALS-

Sign structure: Aluminum with no visible fasteners
Sign area substrate: .080" Aluminum
Copy: First surface applied vinyl
Moulding: Formed polyurethane millwork
Support structure: (2) 3" schedule 40 round steel pipes
Lighting: (2) F96T12DHO lamps w/HO ballast recessed in top soffit
Changeable copy: 4" Rigid letters with locking clear Lexan face cover

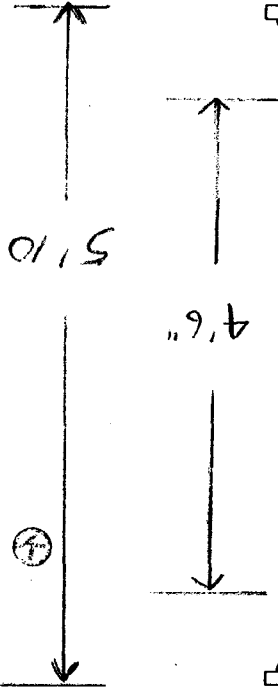
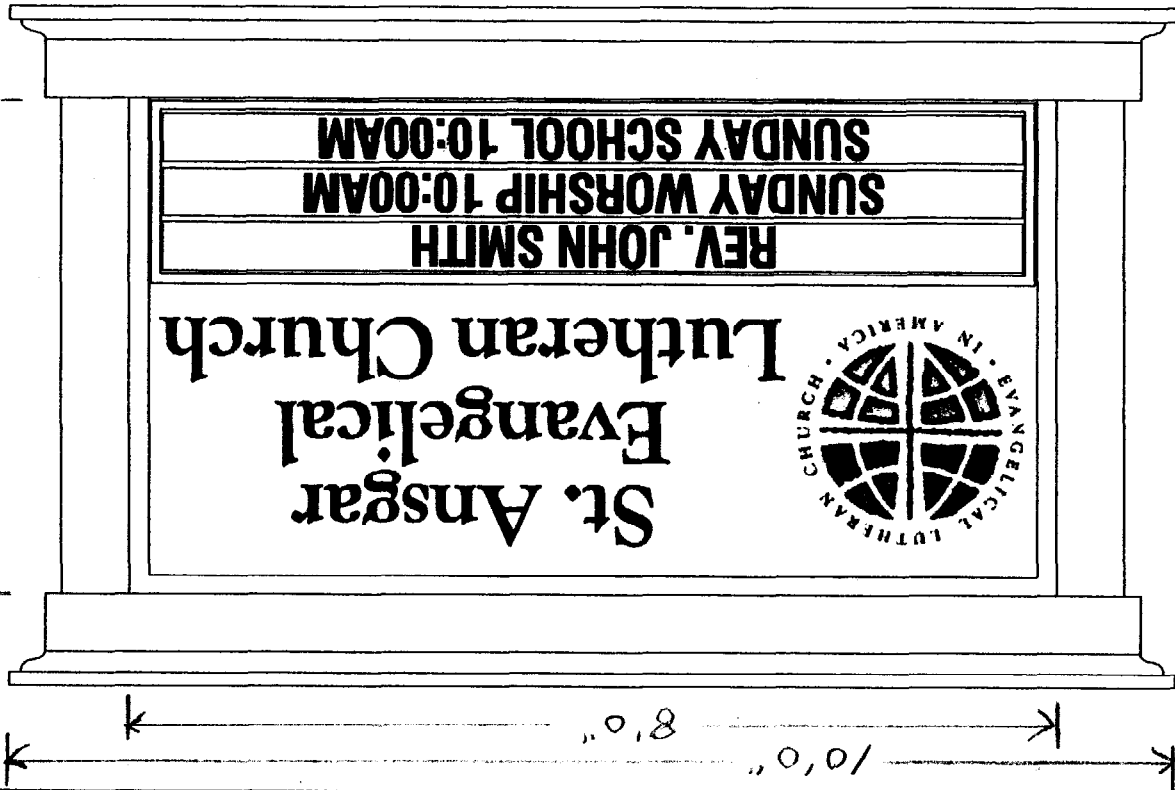



CHECKLIST FOR SIGN/AWNING APPLICATION

Applicants for a sign or awning permit are required to submit the following information to the Code Enforcement Office at the time of application:

- Certificate of Liability listing the City as additional insured if any portion of the sign abuts or encroaches on any public right of way, or can fall into any public right of way. Amount must equal \$400,000.00.
- Letter of permission from the owner indicating the permissions granted and the tenant/space building frontage.
- A sketch plan of lot, indicating location of buildings, driveways, and any abutting streets or rights of way, lengths of building frontages, street frontages, and all existing setbacks. Indicate on the plan all existing and proposed signs with their dimensions and specific locations.
- A sketch or photo of any proposed sign(s) indicating content, dimensions, materials, source of illumination, and construction method, as well as specifics of installation/attachment.
- Certificate of Flammability required for awning or canopy at time of application.
- UL# required for lighted signs at the time of Final Inspection. Failure to provide this information will invalidate the Sign Permit.
- Pre-Application Questionnaire completed and attached. Photos of existing signage attached.

**Permit Fee for signage or awning-with-signage:
\$30.00 plus \$1.00 per square foot of sign.**

**Permit Fee for awning-without-signage is based on cost of work:
\$30.00 for the first \$1,000.00, plus \$7.00 for each additional \$1,000.00.**

St. Ann's Lutheran Church
 515 WOODFORDS ST
 BETHANY, ME

4x4 = 164

86' x 15' = 1290 #
 x 59 = 1454 #

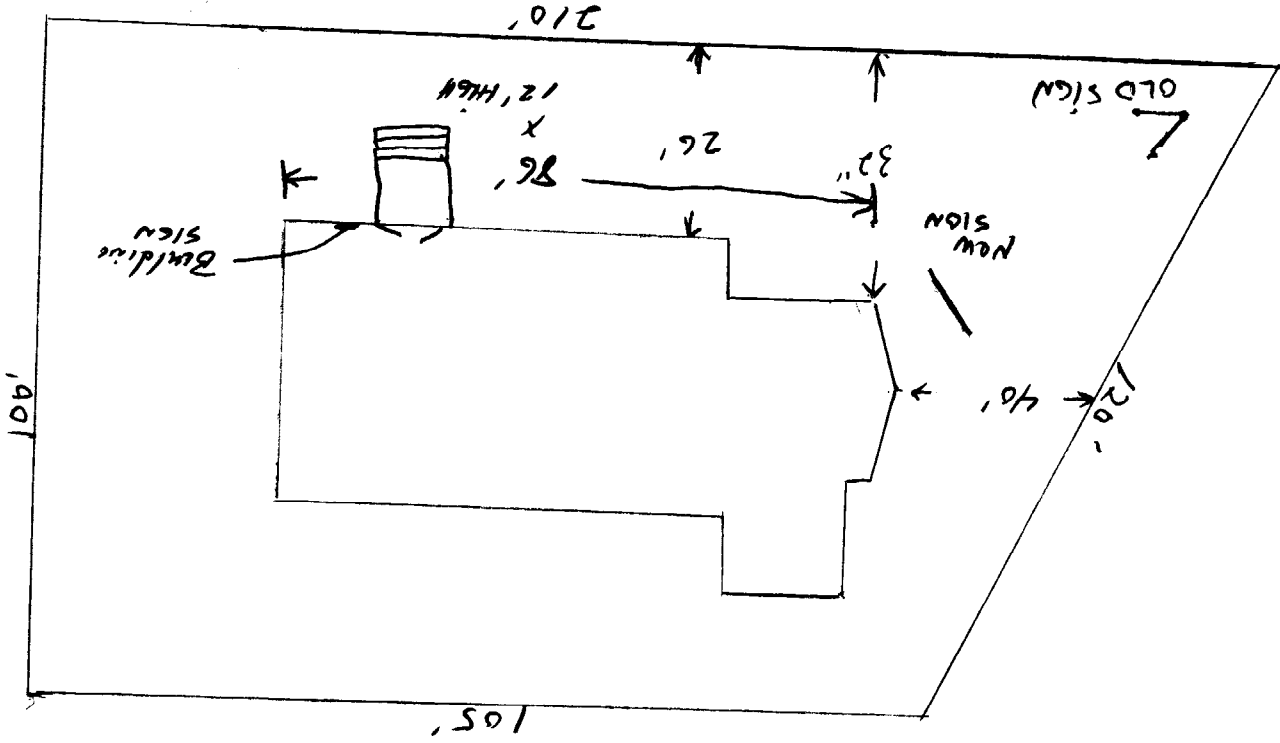

Church Sign

St. Ansgar Evangelical Lutheran Church
515 Woodfords St.
Portland, Me. 04103

Contact: Fran Loranger H.874-6960 W.772-2223 C.415-2910

Preliminary Specs: Front

1. One sided sign lit from above w/ tamper proof light.
2. Changeable letters for worship times and Pastor's name
3. ELCA logo
4. Maintenance free materials
5. Approximate size to be 8' x 4' sign w/roof, base and supports
6. Base of sign to be 1'6" up from the ground
7. Electrical supply by St. Ansgar
8. Allow for future stone base
9. Installation by Burr Sign

Side

1. One sided sign mounted to brick facade
2. St. Ansgar Evangelical Lutheran Church encraved into
Maintenance free material
3. Approximately 4' x 4' w/ arch or gothic top
4. Installation by Burr Sign

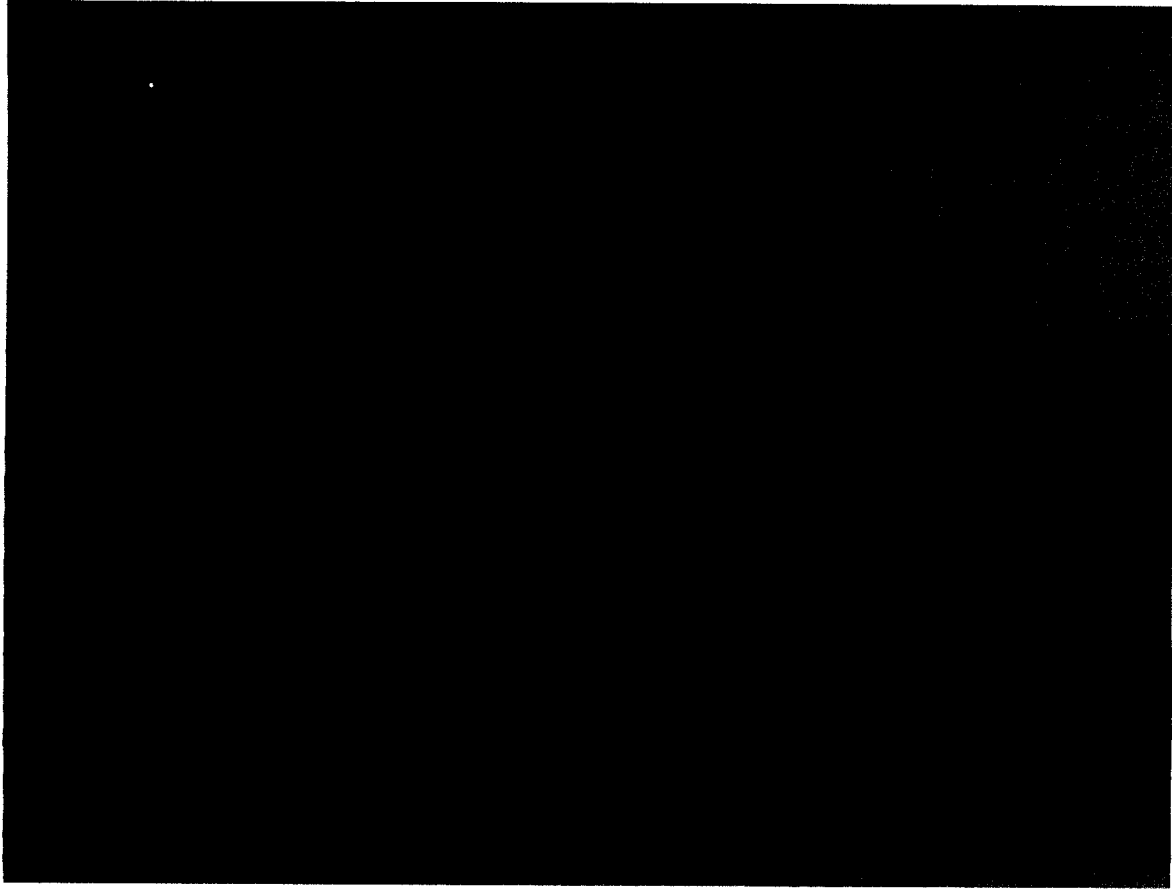

MATERIALS-
Sign area substrate: .75" FCO Sintra (PVC)
Copy: First surface applied vinyl
Moulding: .75" FCO Sintra (PVC)

Sign Elevation - S/F Wallmount

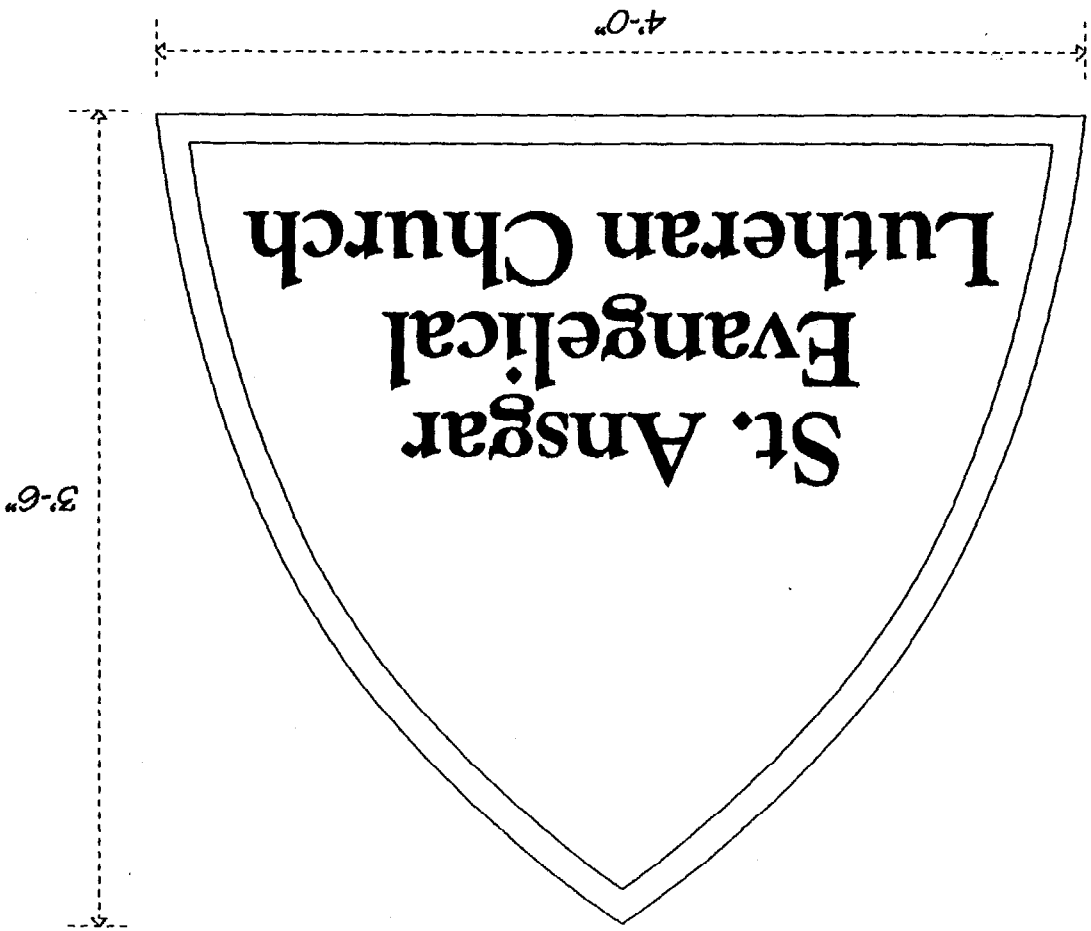

Table 2.2

Institutional Uses in Residential Zones

(Regulations apply to institutions permitted as conditional uses in residential zoning districts. Such uses may include, but are not necessarily limited to, churches, schools, private clubs, fraternal organizations and hospitals.)

Freestanding

	Street Frontage < 100'	Street Frontage 100' to 250'	Street Frontage > 250'
- Area	15 sq. ft.	25 sq. ft.	50 sq. ft.
- Height	6 ft.	8 ft.	8 ft.
- Setback	5 ft.	5 ft.	5 ft.
- # Freestanding signs per lot	1/st. frontage (a)(b)	1/st. frontage (a)(b)	1/st. frontage (a)(b)

(a) Lots fronting on two or more streets are allowed one freestanding sign for each frontage. However, the area of each sign shall correspond to the length of the applicable frontage. Freestanding signs shall be positioned such that they are not readily concurrently visible.

(b) Where one lot contains more than one affiliated use, each use shall be allowed one sign per street frontage.

Note: Pertinent directional information shall, to the extent possible, be included on the principal freestanding sign. Additional directional signs shall be allowed only in the event that necessary information cannot fit reasonably within the permitted sign area. The size of additional signs shall be the minimum necessary to achieve the informational objective.

Building Signs (a)

- Maximum permitted sign area	na
- % of wall area on which sign is to be placed	5%
- # building signs permitted per lot	1/bldg. face (b)

(a) Building signs shall be reviewed for compliance with sign standard(s) included in site plan ordinance and shall under no circumstances be internally illuminated.

(b) One sign is allowed per building face provided such signs are not readily concurrently visible.

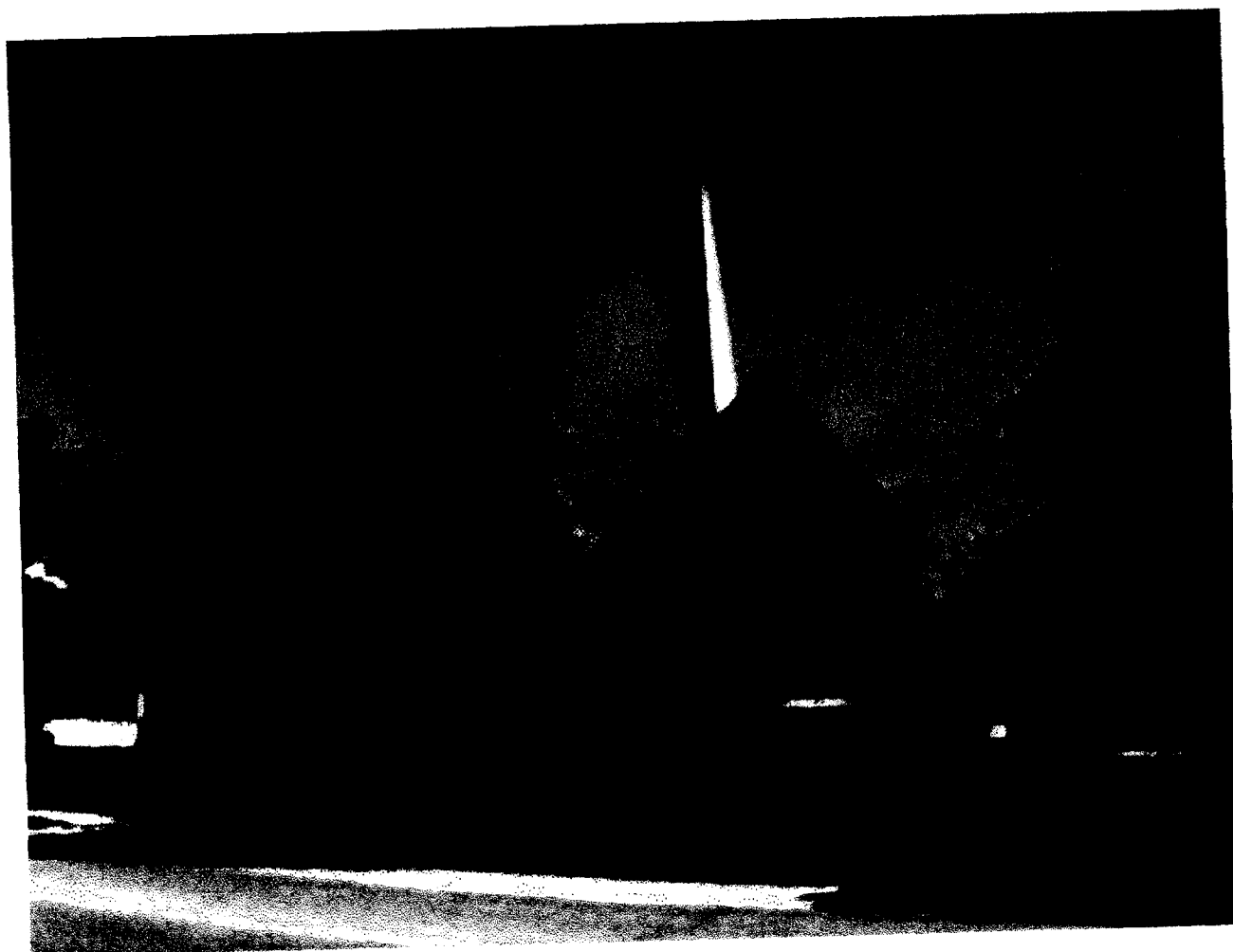

City of Portland, Maine - Building or Use Permit Application

389 Congress Street, 04101 Tel: (207) 874-8703, Fax: (207) 874-8716

Permit No: 03-1087	Issue Date:	CBL: 184 C001001
-----------------------	-------------	---------------------

Location of Construction: 5 Columbia Rd	Owner Name: St Ansgar Evangelical	Owner Address: 515 Woodford St	Phone: 774-8740
Business Name:	Contractor Name: Burr Signs	Contractor Address: 10 Buttonwood St. So. Portland	Phone: 2077991183
Lessee/Buyer's Name	Phone:	Permit Type: Signs - Permanent	Zone: R5

Past Use: St. Ansgar Lutheran Church	Proposed Use: St. Ansgar Lutheran Church	Permit Fee: \$132.40	Cost of Work: \$0.00	CEO District: 3
		FIRE DEPT: <input checked="" type="checkbox"/> Approved <input type="checkbox"/> Denied <i>Never PD</i>	INSPECTION: Use Group: Type:	

Proposed Project Description:
Erect an 8' x4.6" sign and a 3.6"x4' Sign

Signature:	Signature:
PEDESTRIAN ACTIVITIES DISTRICT (P.A.D.)	
Action: <input type="checkbox"/> Approved <input type="checkbox"/> Approved w/Conditions <input type="checkbox"/> Denied	Date:

Permit Taken By: gad	Date Applied For: 09/05/2003	Zoning Approval
-------------------------	---------------------------------	------------------------

- This permit application does not preclude the Applicant(s) from meeting applicable State and Federal Rules.
- Building permits do not include plumbing, septic or electrical work.
- Building permits are void if work is not started within six (6) months of the date of issuance. False information may invalidate a building permit and stop all work..

Special Zone or Reviews <input type="checkbox"/> Shoreland <input type="checkbox"/> Wetland <input type="checkbox"/> Flood Zone <input type="checkbox"/> Subdivision <input type="checkbox"/> Site Plan Maj <input type="checkbox"/> Minor <input type="checkbox"/> MM <input type="checkbox"/> Date:	Zoning Appeal <input checked="" type="checkbox"/> Variance # 03-1163 <input type="checkbox"/> Miscellaneous <input type="checkbox"/> Conditional Use <input type="checkbox"/> Interpretation <input type="checkbox"/> Approved <input type="checkbox"/> Denied Date:	Historic Preservation <input checked="" type="checkbox"/> Not in District or Landmark <input type="checkbox"/> Does Not Require Review <input type="checkbox"/> Requires Review <input type="checkbox"/> Approved <input type="checkbox"/> Approved w/Conditions <input type="checkbox"/> Denied Date:
---	--	--

CERTIFICATION

I hereby certify that I am the owner of record of the named property, or that the proposed work is authorized by the owner of record and that I have been authorized by the owner to make this application as his authorized agent and I agree to conform to all applicable laws of this jurisdiction. In addition, if a permit for work described in the application is issued, I certify that the code official's authorized representative shall have the authority to enter all areas covered by such permit at any reasonable hour to enforce the provision of the code(s) applicable to such permit.

SIGNATURE OF APPLICANT _____ ADDRESS _____ DATE _____ PHONE _____

RESPONSIBLE PERSON IN CHARGE OF WORK, TITLE _____ DATE _____ PHONE _____

From: Marge Schmuckal
To: PENNY LITTELL
Date: Thu, Sep 11, 2003 12:33 PM
Subject: church signs

Penny,

Just a reminder that we need the sign fee which was calculated at \$132.40, a copy of a liability binder for insurance, and the length of the church on the side that will have the attached sign. The building side will also need to see specifics as to how that building sign will be attached to the building.

NO fee - no review - no permit

Thanks, Marge

03-1087

Signage/Awning Permit Application

If you or the property owner owes real estate or personal property taxes or user charges on any property within the City, payment arrangements must be made before permits of any kind are accepted.

5 Columbia Road

Location/Address of Construction: <u>515 WOODFORDS ST.</u>		
Total Square Footage of Proposed Structure <u>36' SQ FT SIGNAGE / 58' SQ FT Structure</u>	Square Footage of Lot <u>25 200' SQ FT</u>	
Tax Assessor's Chart, Block & Lot Chart# <u>184</u> Block# <u>C</u> Lot# <u>123</u>	Owner: <u>ST. ANSGAR CHURCH</u>	Telephone: <u>774-8740</u>
Lessee/Buyer's Name (if Applicable)	Applicant name, address & telephone: <u>ST. ANSGAR LUTHERAN CHURCH</u> <u>515 WOODFORDS ST.</u> <u>PORTLAND, MAINE 04103</u> <u>774-8740</u>	Total s.f. of signage x \$1.00 per s.f. plus \$30.00 = Total Fee: \$ <u>2102.40</u> Awning Fee = Cost Of Work \$ <u>30.00</u> Total Fee: \$ <u>132.40</u>
Current use: <u>CHURCH</u>	<u>8' x 4'6" = 36.80</u>	
If the location is currently vacant, what was prior use:	<u>3'6" x 4' = 14.40</u>	
Approximately how long has it been vacant: _____		
Proposed use: _____		
Project description: <u>2 signs one 8' x 4'6" and one</u> <u>3'6" x 4'</u>		
Contractor's name, address & telephone:		
Who should we contact when the permit is ready: <u>BURR SIGNS</u>		
Mailing address: <u>10 BUTTERWOOD ST.</u> <u>SO. PORTLAND, ME 04106</u>		
We will contact you by phone when the permit is ready. You must come in and pick up the permit and review the requirements before starting any work, with a Plan Reviewer. A stop work order will be issued and a \$100.00 fee if any work starts before the permit is picked up. PHONE: <u>799-1193</u>		

IF THE REQUIRED INFORMATION IS NOT INCLUDED IN THE SUBMISSIONS THE PERMIT WILL BE AUTOMATICALLY DENIED AT THE DISCRETION OF THE BUILDING/PLANNING DEPARTMENT. WE MAY REQUIRE ADDITIONAL INFORMATION IN ORDER TO APPROVE THIS PERMIT.

I hereby certify that I am the Owner of record of the named property, or that the owner of record authorizes the proposed work and that I have been authorized by the owner to make this application as his/her authorized agent. I agree to conform to all applicable laws of this jurisdiction. In addition, if a permit for work described in this application is issued, I certify that the Code Official's authorized representative shall have the authority to enter all areas covered by this permit at any reasonable hour to enforce the provisions of the codes applicable to this permit.

Signature of applicant: <u>Fran Lorange</u>	Date: _____
---	-------------

This is NOT a permit, you may not commence ANY work until the permit is issued

SIGNAGE/AWNING PRE-APPLICATION QUESTIONNAIRE

PLEASE ANSWER ALL QUESTIONS

ADDRESS: 515 WOODFORD ST, PORTLAND ZONE: R5

CBL: 184-C-1-2-3
cor Columbia Rd

SINGLE TENANT LOT? YES NO MULTI TENANT LOT? YES NO
MORE THAN ONE SIGN TOTAL WITH PROPOSED SIGN? YES NO

INFORMATION ON PROPOSED SIGN(S):

FREESTANDING (e.g., pole) SIGN? YES NO DIMENSIONS PROPOSED: 8' x 4' 6" / 10' x 5' 10"
BLDG. WALL SIGN? (attached to bldg) YES NO DIMENSIONS PROPOSED: 4' x 3' 6" #14

INFORMATION ON ALREADY EXISTING AND PERMITTED SIGN(S):

FREESTANDING (e.g., pole) SIGN? YES NO DIMENSIONS: 6' x 4' *to be removed*
BLDG. WALL SIGN(attached to bldg)? YES NO DIMENSIONS: _____
AWNING? YES NO DIMENSIONS: _____

LOT FRONTAGE (FEET): 120' x 210'
TENANT/ALLOCATED BUILDING SPACE FRONTAGE (FEET): _____

AWNING YES NO IS AWNING BACKLIT? YES NO

HEIGHT OF AWNING: _____ LENGTH OF AWNING: _____ DEPTH: _____

IS THERE ANY COMMUNICATION, MESSAGE, TRADEMARK OR SYMBOL ON IT? YES NO

IF YES, TOTAL S.F. OF PANELS WITH COMMUNICATIONS/MESSAGE/TRADEMARK/SYMBOL? _____ s.f.

A SITE SKETCH AND BUILDING SKETCH SHOWING EXACTLY WHERE EXISTING AND NEW SIGNAGE IS LOCATED MUST BE PROVIDED. SKETCHES AND/OR PICTURES OF PROPOSED SIGNAGE ARE ALSO REQUIRED.

SIGNATURE OF APPLICANT: Fran Corayer DATE: _____

***** FOR OFFICE USE ONLY *****

CHECKLIST FOR SIGN/AWNING APPLICATION

Applicants for a sign or awning permit are required to submit the following information to the Code Enforcement Office at the time of application:

- Certificate of Liability listing the City as additional insured if any portion of the sign abuts or encroaches on any public right of way, or can fall into any public right of way. Amount must equal \$400,000.00.
- Letter of permission from the owner indicating the permissions granted and the tenant/space building frontage.
- A sketch plan of lot, indicating location of buildings, driveways, and any abutting streets or rights of way, lengths of building frontages, street frontages, and all existing setbacks. Indicate on the plan all existing and proposed signs with their dimensions and specific locations.
- A sketch or photo of any proposed sign(s) indicating content, dimensions, materials, source of illumination, and construction method, as well as specifics of installation/attachment.
- Certificate of Flammability required for awning or canopy at time of application.
- UL# required for lighted signs at the time of Final Inspection. Failure to provide this information will invalidate the Sign Permit.
- Pre-Application Questionnaire completed and attached. Photos of existing signage attached.

**Permit Fee for signage or awning-with-signage:
\$30.00 plus \$1.00 per square foot of sign.**

**Permit Fee for awning-without-signage is based on cost of work:
\$30.00 for the first \$1,000.00, plus \$7.00 for each additional \$1,000.000.**

no visible fasteners
minimum
millwork
40 round steel pipes
w/HO ballast recessed in top soffit
with locking clear Lexan face cover

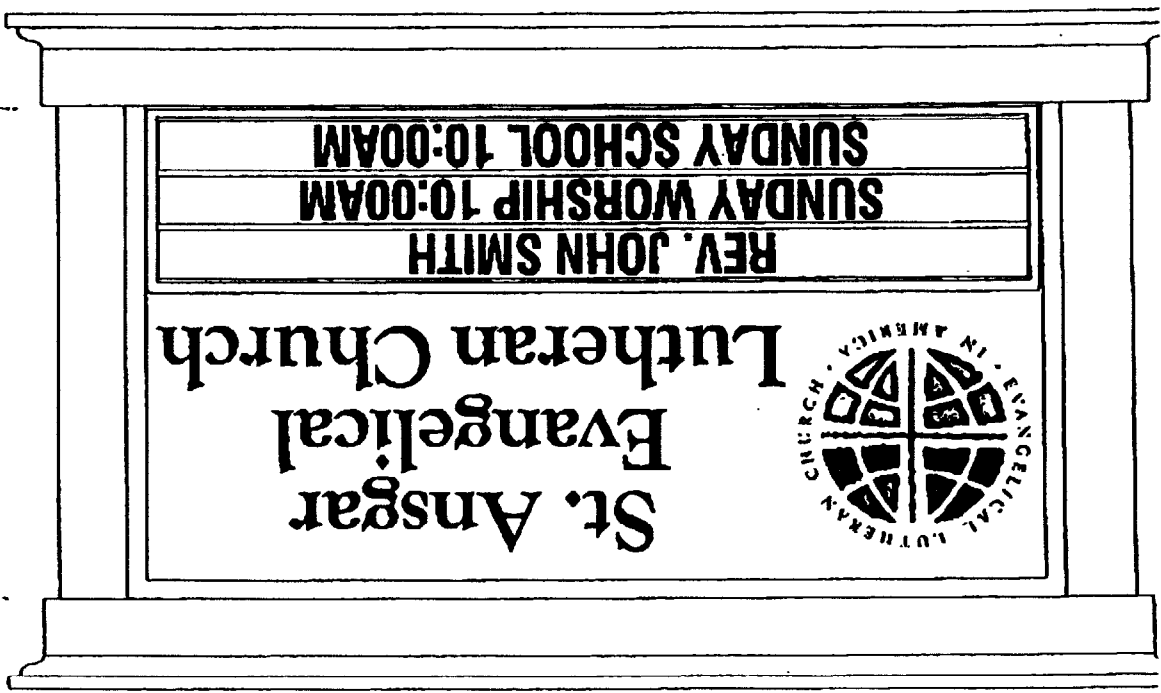

COLORS SHOWN HERE MAY NOT REPRESENT ACTUAL COLORS BE REQUIRED.	
DRAWING NO St Ansgar 3.cdl	CLIENT ST. ANSGAR PORTLAND, ME
DATE 02/13/03	SALES PERSON R. BURR
SCALE 1" = 20"	DRAWN BY R. BURR
ACCEPTANCE SIGNATURE	LOCATION PORTLAND, ME
THIS DESIGN IS THE EXCLUSIVE PROPERTY OF BURR SIGNS. ALL PRODUCTION AND REPRODUCTION RIGHTS ARE RESERVED BY US. THIS PRINT HAS BEEN DESIGNED FOR YOUR PERSONAL USE. IT MAY NOT BE SUBMITTED, USED OR EXHIBITED OUTSIDE OF YOUR COMPANY OR ORGANIZATION WITHOUT THE EXPRESSED WRITTEN PERMISSION OF BURR SIGNS.	LOCATION PORTLAND, ME
BURR SIGNS 10 BIRCHWOOD ST PORTLAND, ME 04106 TEL: 207-799-1183 FAX: 207-799-1334	SALES PERSON R. BURR
BURR SIGNS	DRAWN BY R. BURR
BURR SIGNS	DATE 02/13/03
BURR SIGNS	ACCEPTANCE SIGNATURE
BURR SIGNS	DRAWING NO St Ansgar 3.cdl



© Copyright

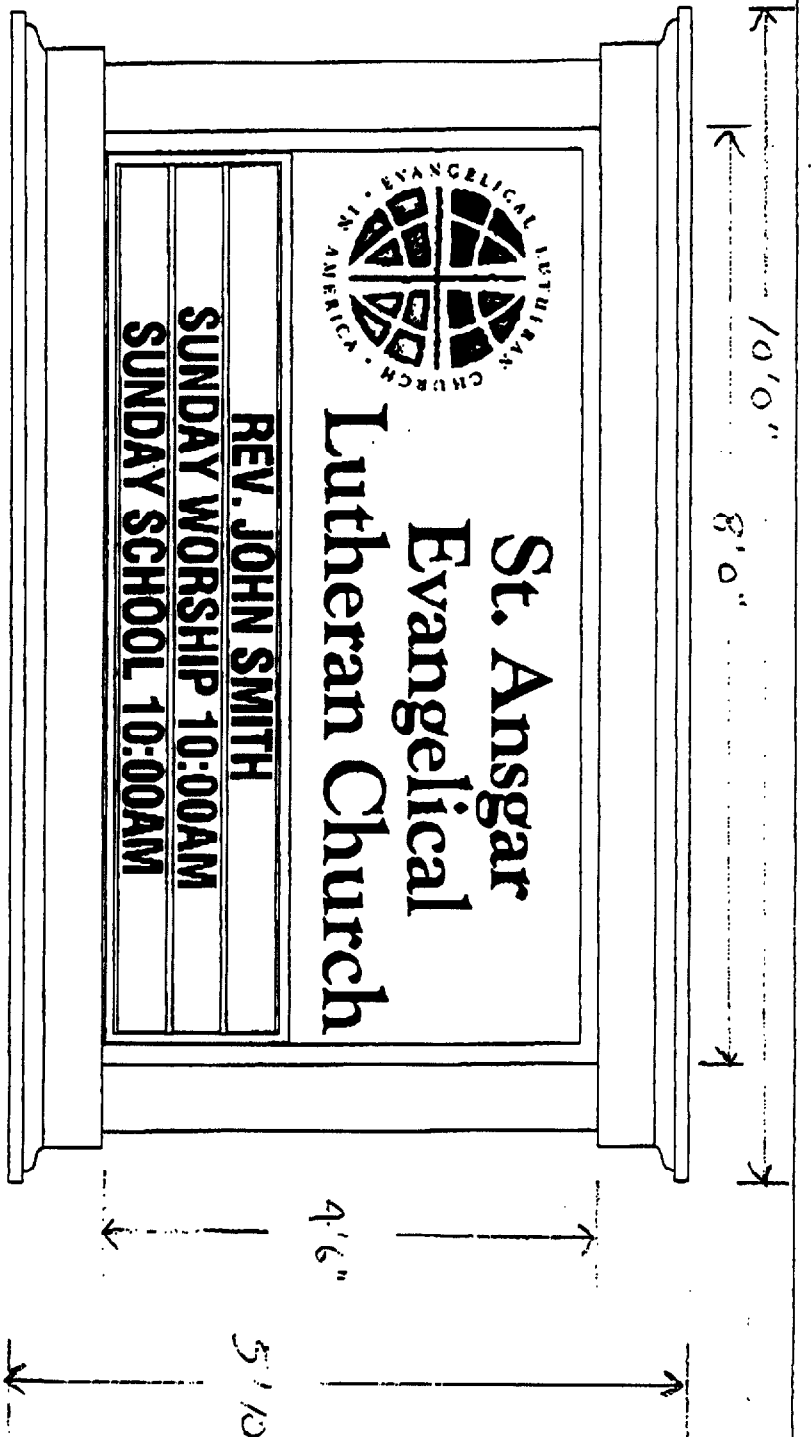

Sign Elevation

MATERIALS-

- Sign structure: Aluminum with no visible fasteners
- Sign area substrate: .080" Aluminum
- Copy: First surface applied vinyl
- Moulding: Formed polyurethane millwork
- Support structure: (2) 3" schedule 40 round steel pipes
- Lighting: (2) F96T12DHO lamps w/HO ballast recessed in top soffit
- Changeable copy: 4" Rigid letters with locking clear Lexan face cover

4.5 x 8 = 36

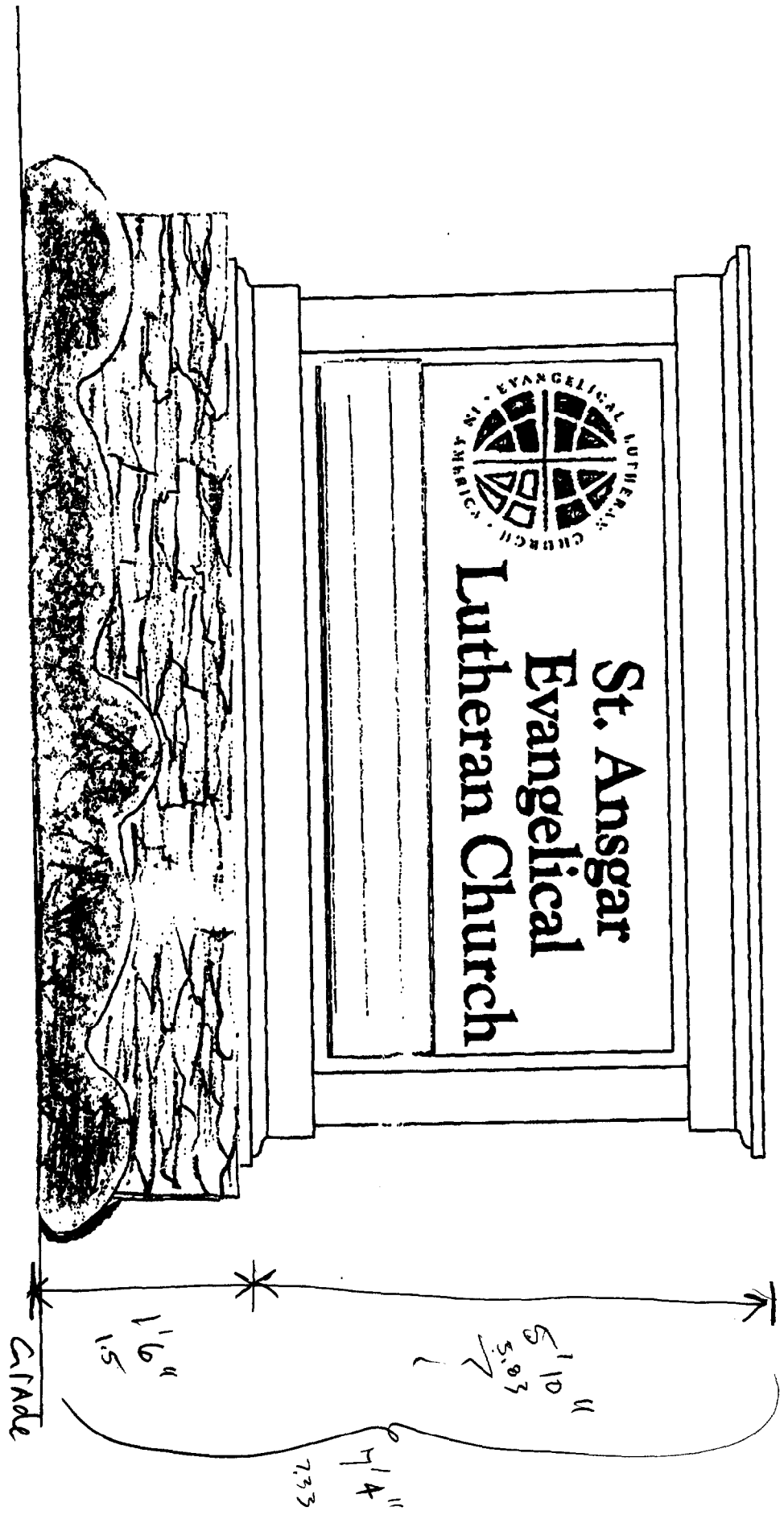

**St. Ansgar
Evangelical
Lutheran Church**

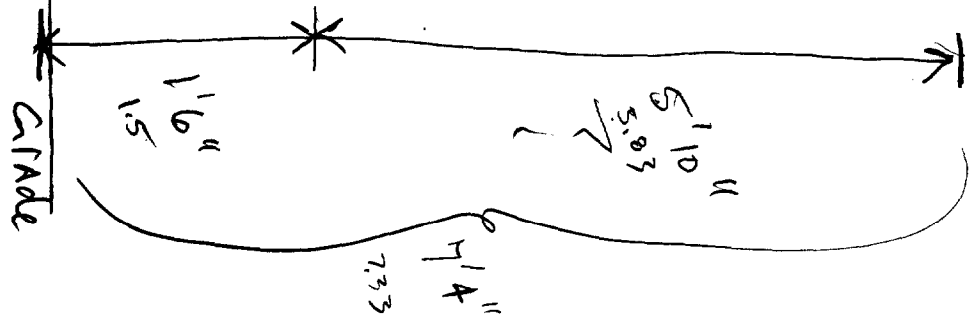

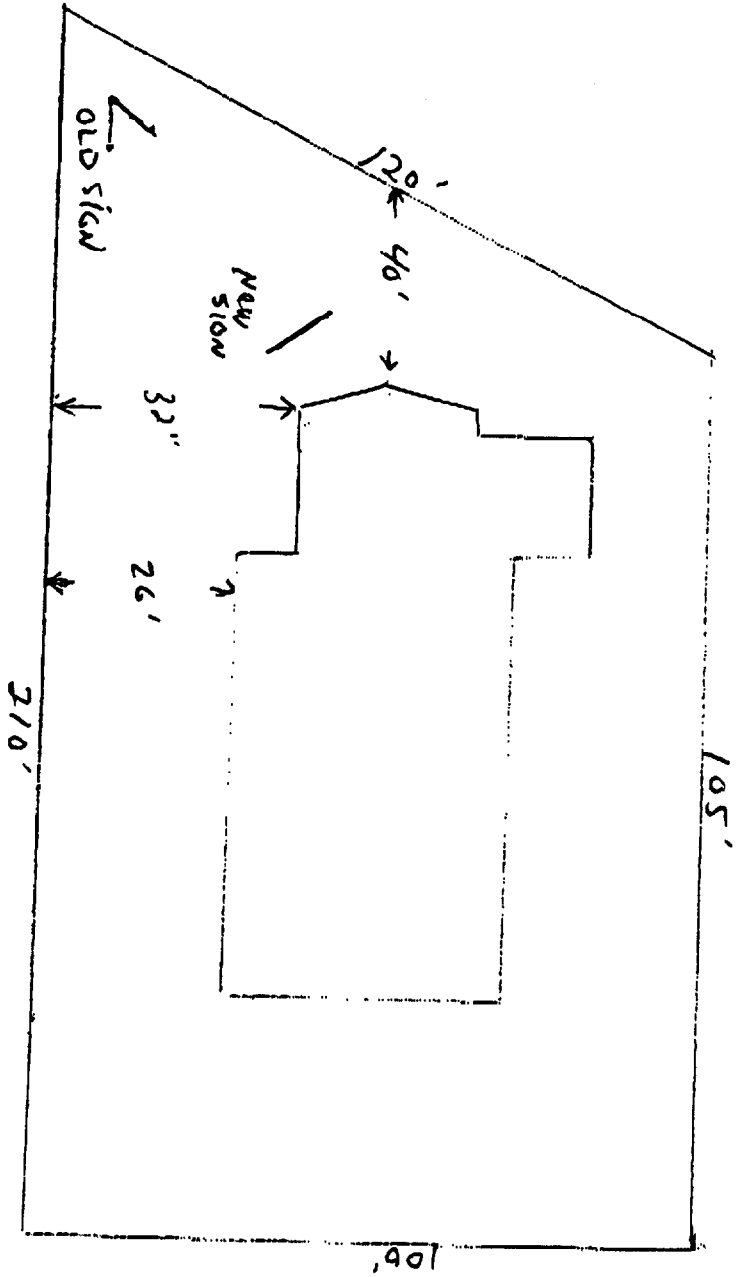

St. Ann's Lutheran Church
515 Woodford St
Barrano, Me

Church Sign

St. Ansgar Evangelical Lutheran Church
515 Woodfords St.
Portland, Me. 04103

Contact: Fran Loranger H.874-6960 W.772-2223 C.415-2910

Preliminary Specs: Front

1. One sided sign lit from above w/ tamper proof light.
2. Changeable letters for worship times and Pastor's name
3. ELCA logo
4. Maintenance free materials
5. Approximate size to be 8' x 4' sign w/roof, base and supports
6. Base of sign to be 1'6" up from the ground
7. Electrical supply by St. Ansgar
8. Allow for future stone base
9. Installation by Burr Sign

Side

1. One sided sign mounted to brick facade
2. St. Ansgar Evangelical Lutheran Church encraved into
Maintenance free material
3. Approximately 4' x 4' w/ arch or gothic top
4. Installation by Burr Sign

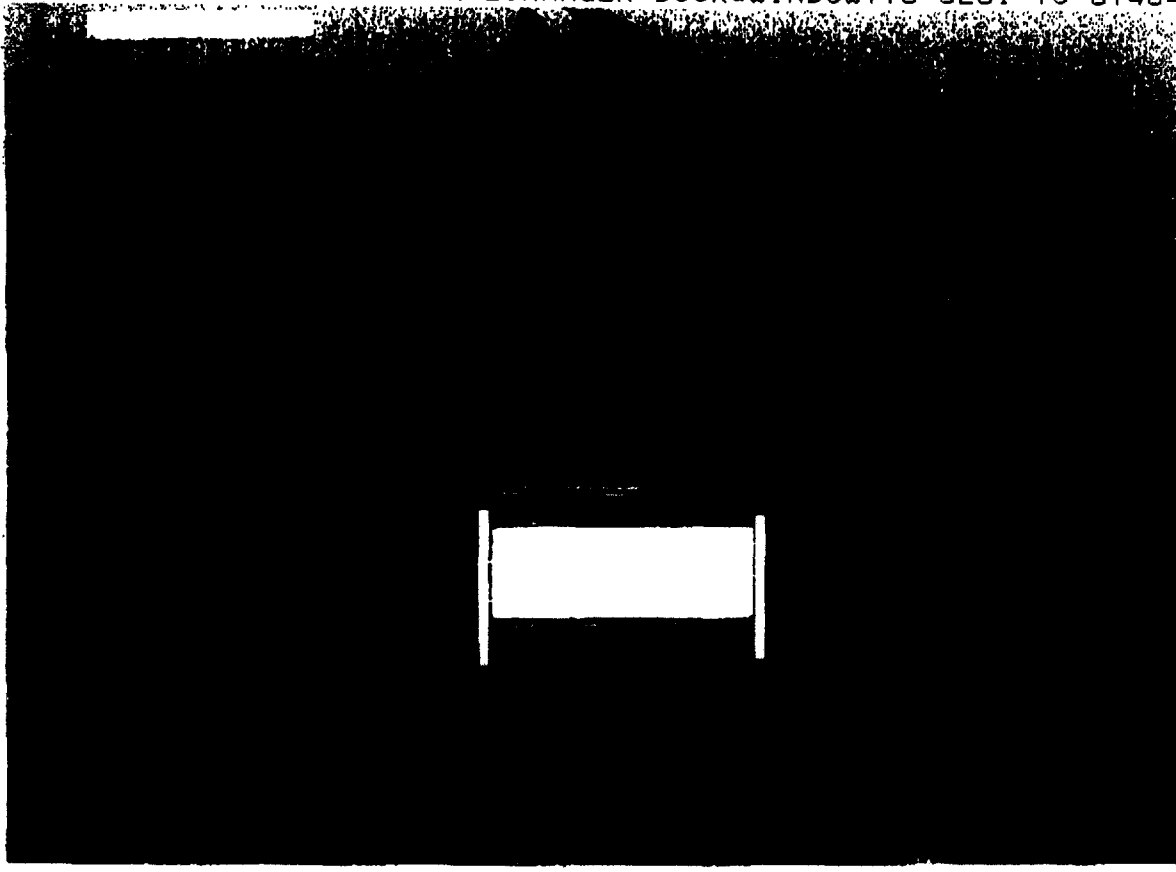

NOT TO SCALE

EXISTING SIGN

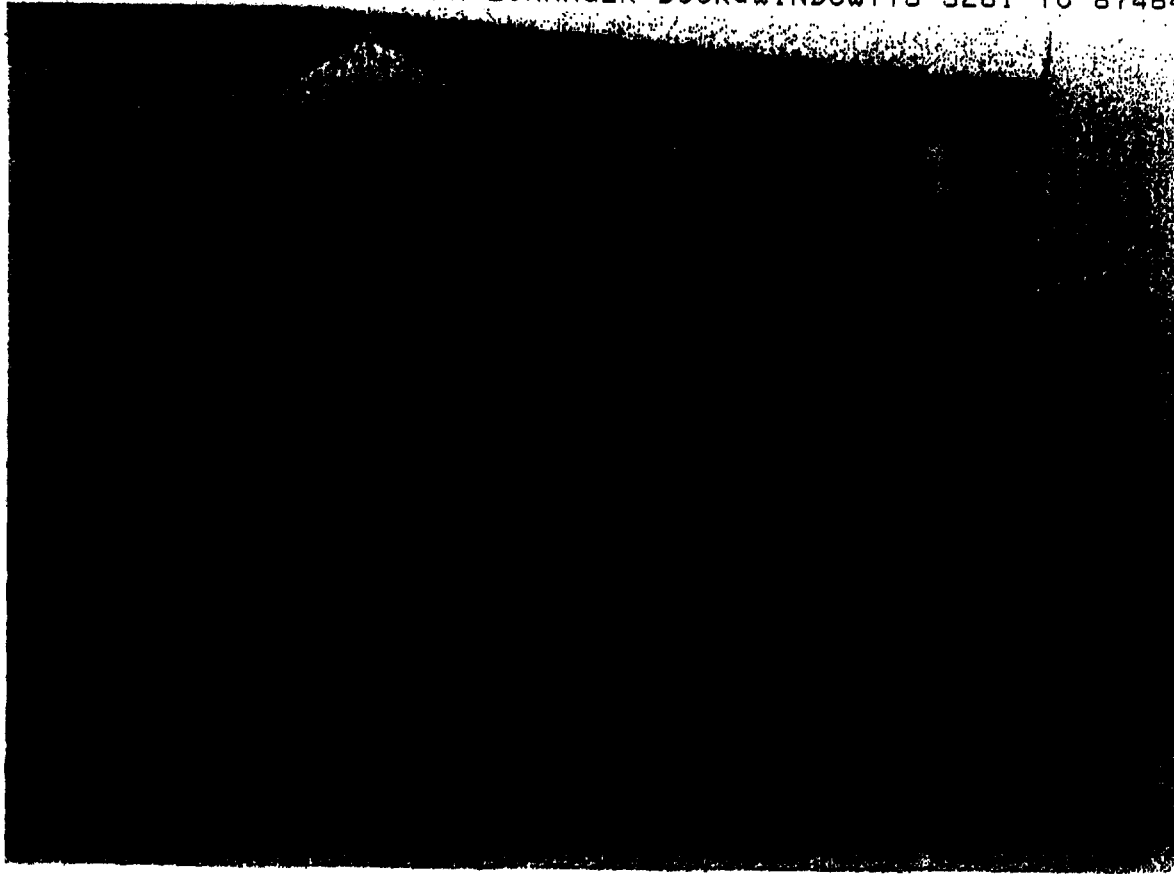

What is the size

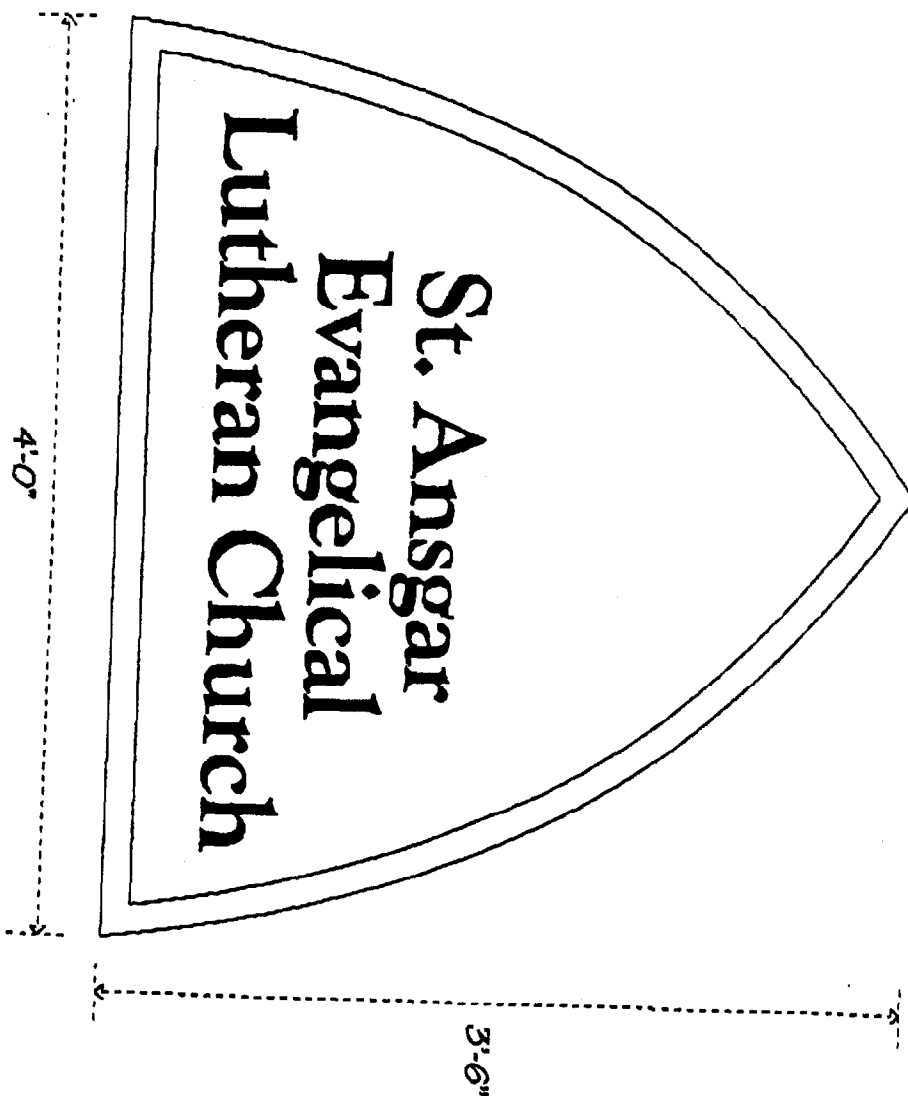

Sign Elevation - S/F Walkmount

MATERIALS-

Sign area substrate: 75" FCO Sintra (PVC)
Copy: First surface applied vinyl
Moulding: 75" FCO Sintra (PVC)