

No.	Date	Issued for
1	11/22/13	80% Review Set
2	01/24/14	Bid and Permit

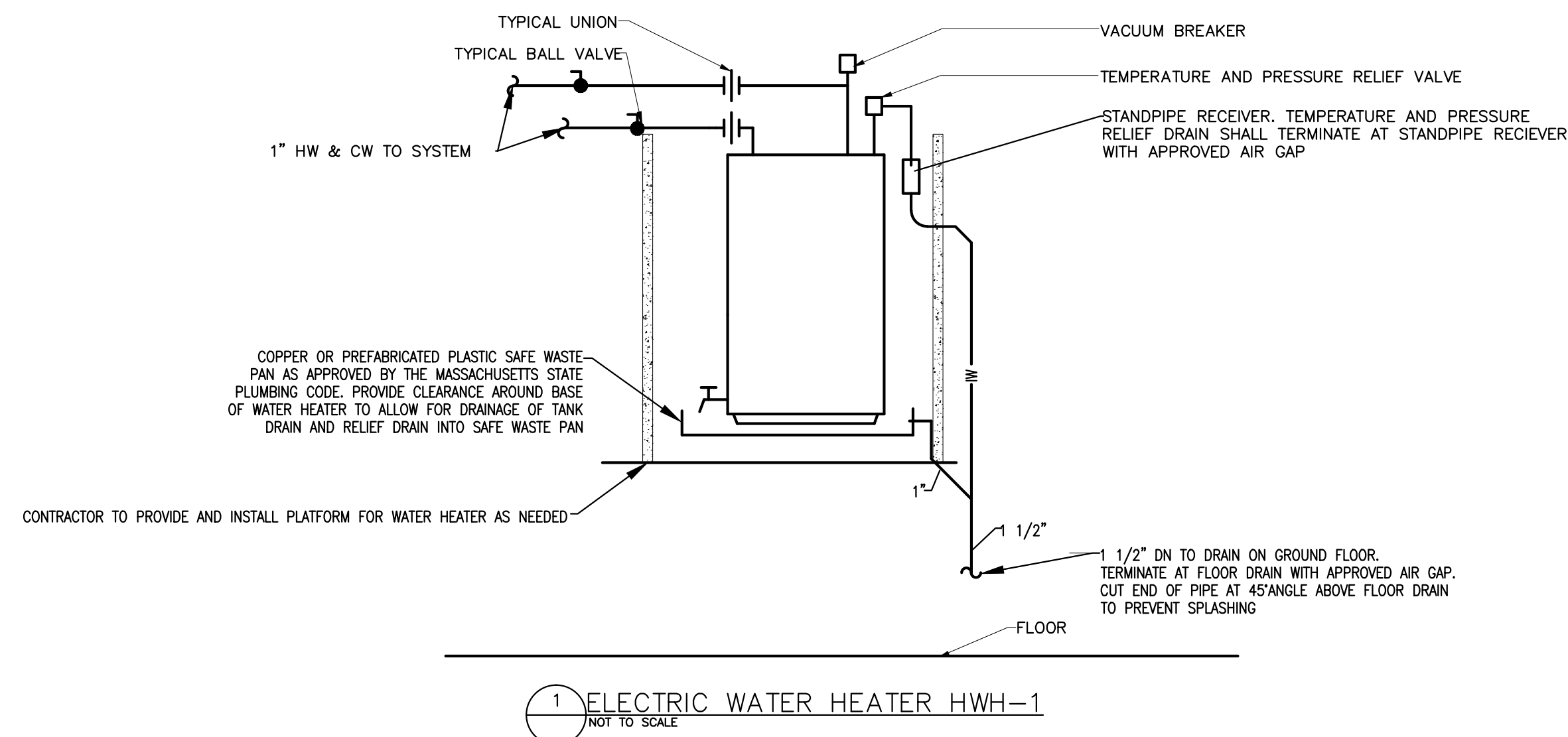

1 ELECTRIC WATER HEATER HWH-1  
NOT TO SCALE

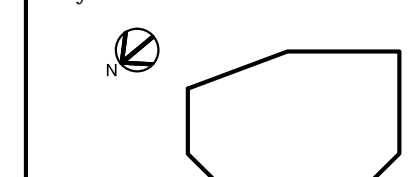
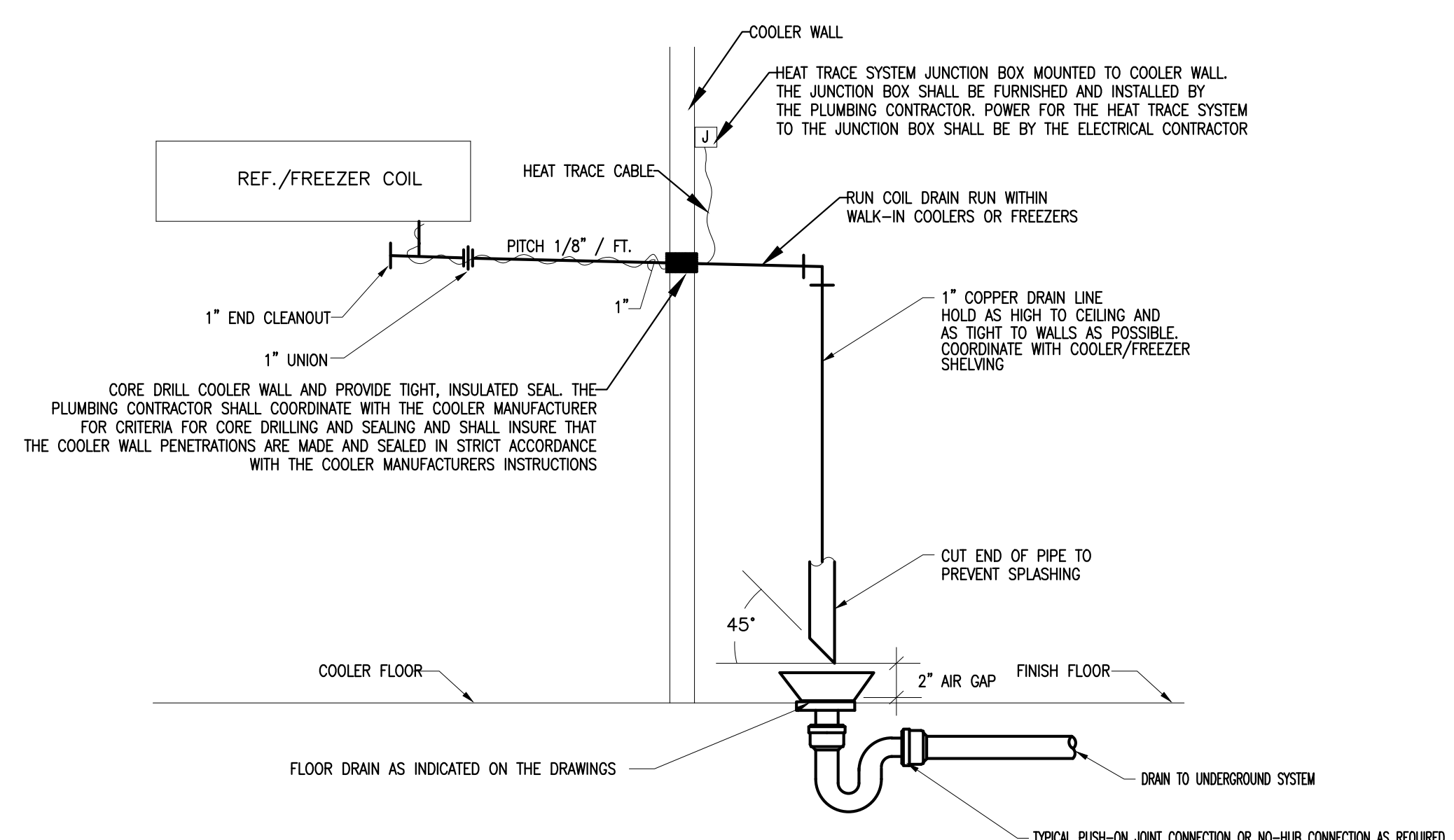

2 TYPICAL COOLER/FREEZER COIL DRAIN  
NOT TO SCALE

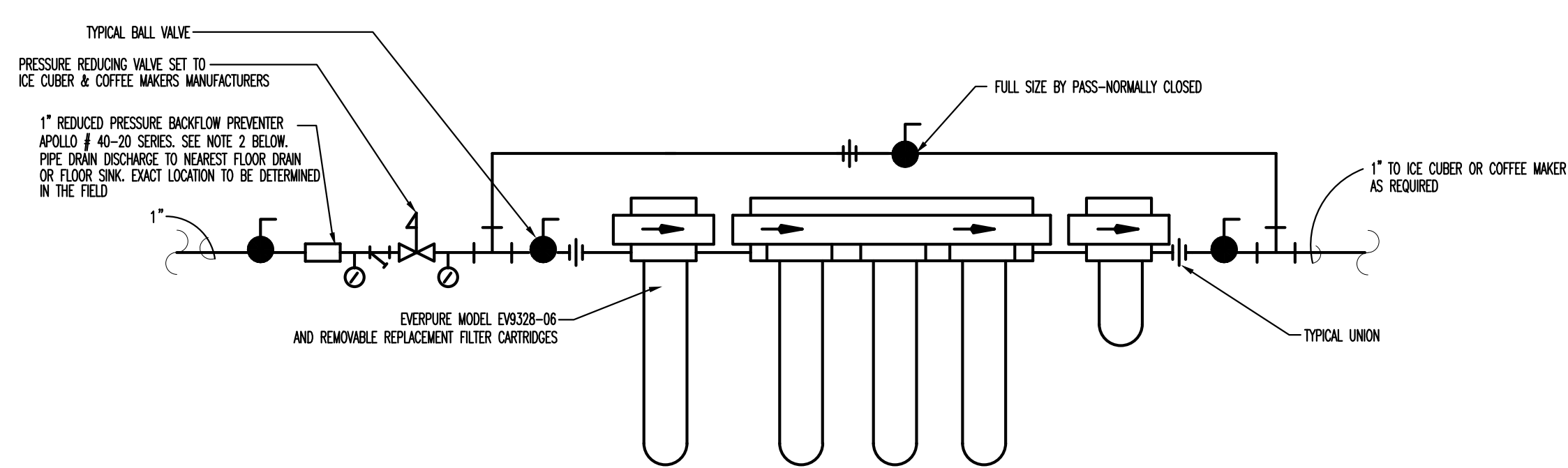

- NOTE**
1. PRESSURE REDUCING VALVE SHALL BE WILKINS 500YSR
  2. ENTIRE INSTALLATION SHOWN SHALL BE MOUNTED EXPOSED ON WALL AND READILY ACCESSIBLE

3 TYPICAL WATER FILTER DETAIL  
NOT TO SCALE

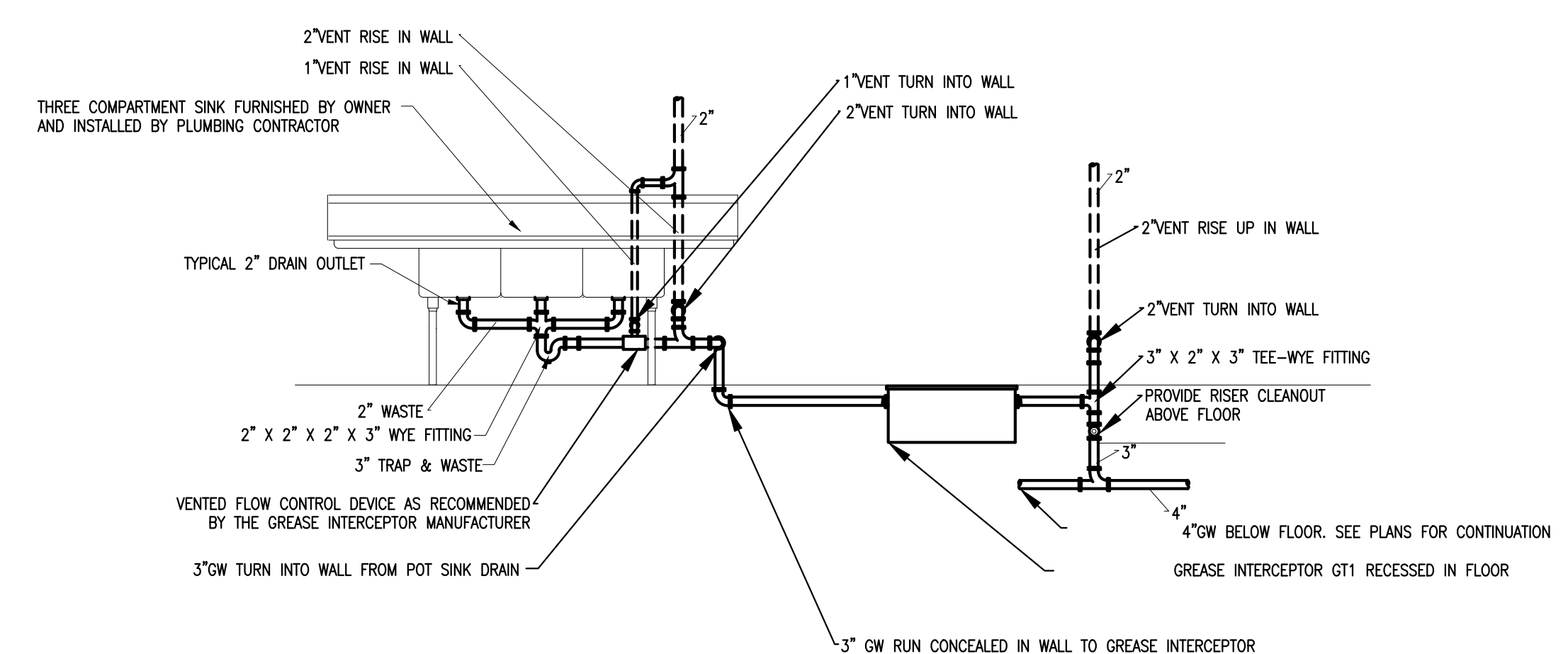

**NOTE:**  
TRIPLE POT SINK BAYS SHALL BE LABELLED WITH PROPER SIGNAGE PER 248 CMR

4 TRIPLE COMPARTMENT POT SINK  
NOT TO SCALE

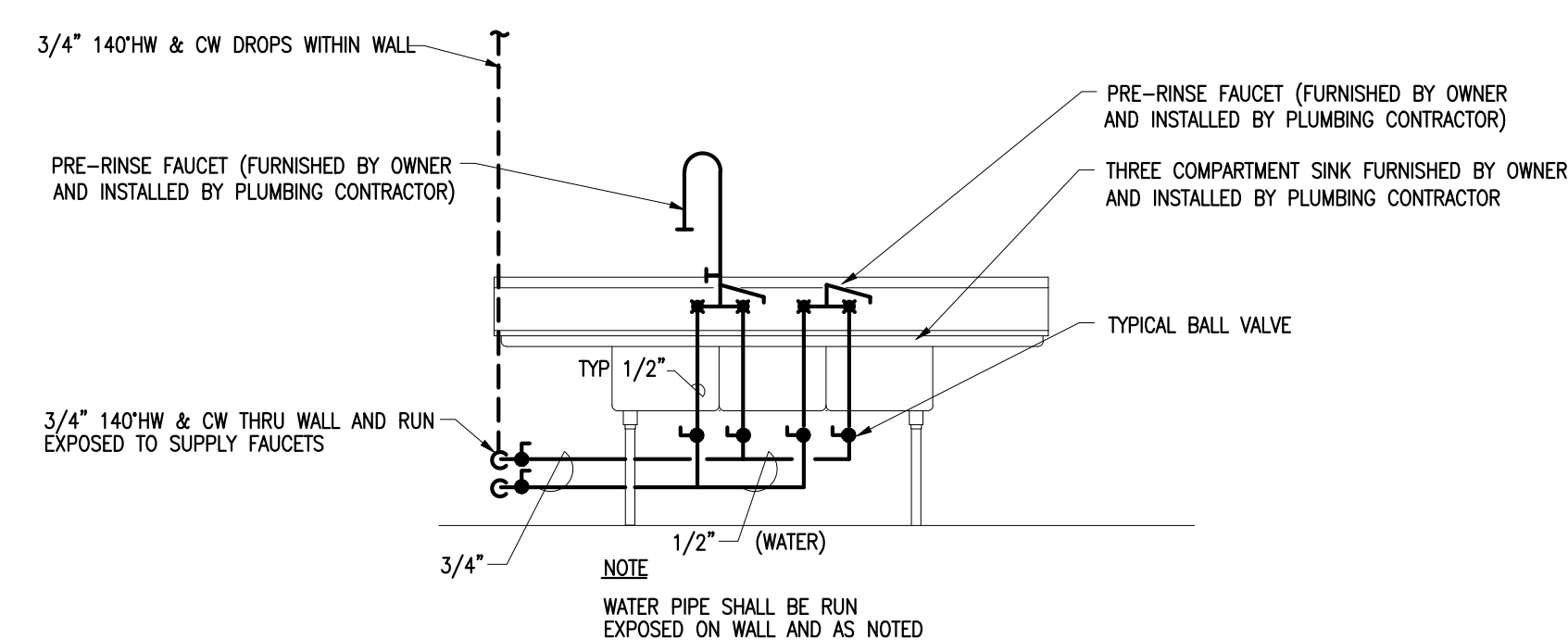

5 TRIPLE COMPARTMENT POT SINK  
NOT TO SCALE