

HVAC DETAILS

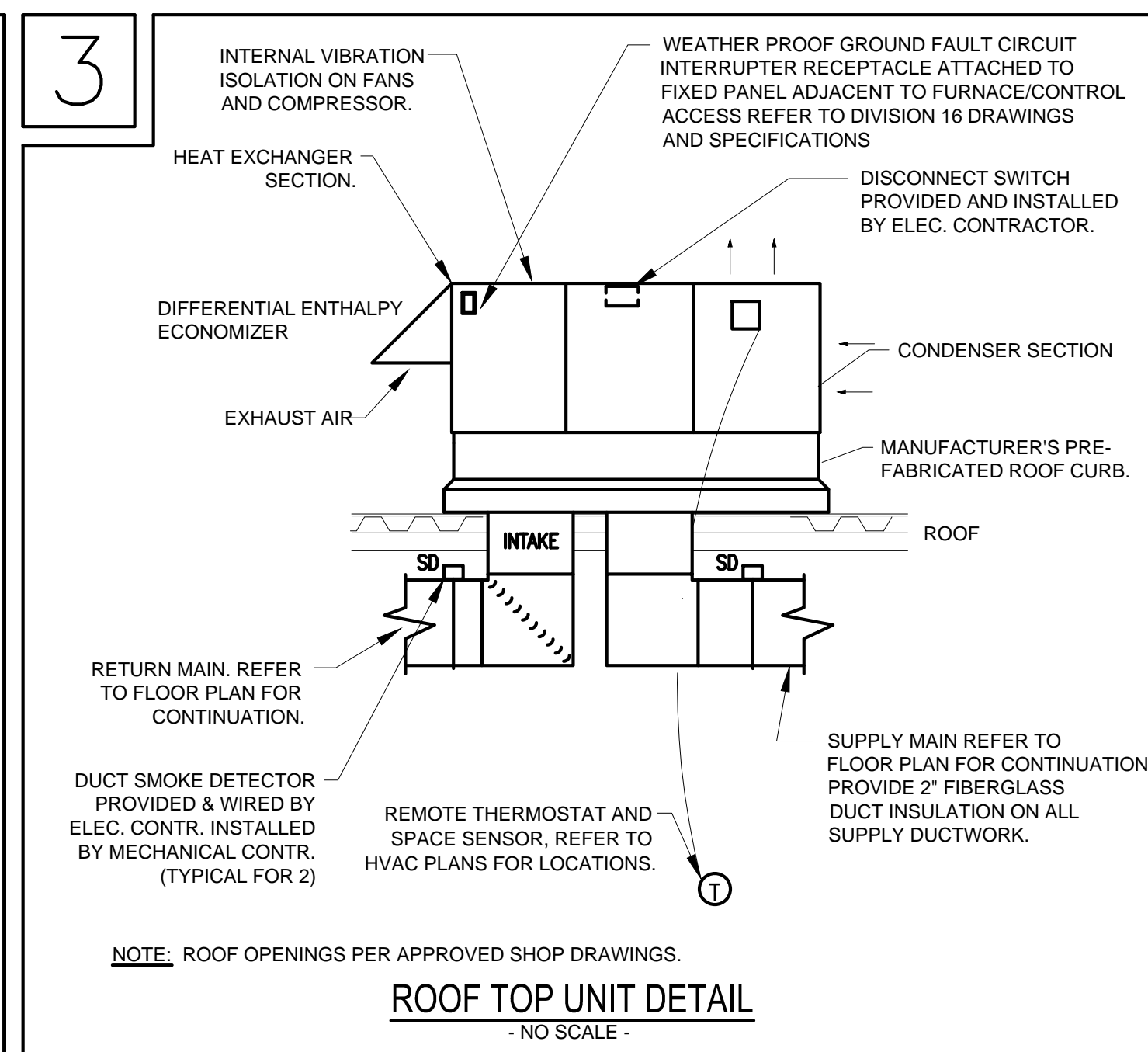

HVAC SEQUENCE OF OPERATIONS

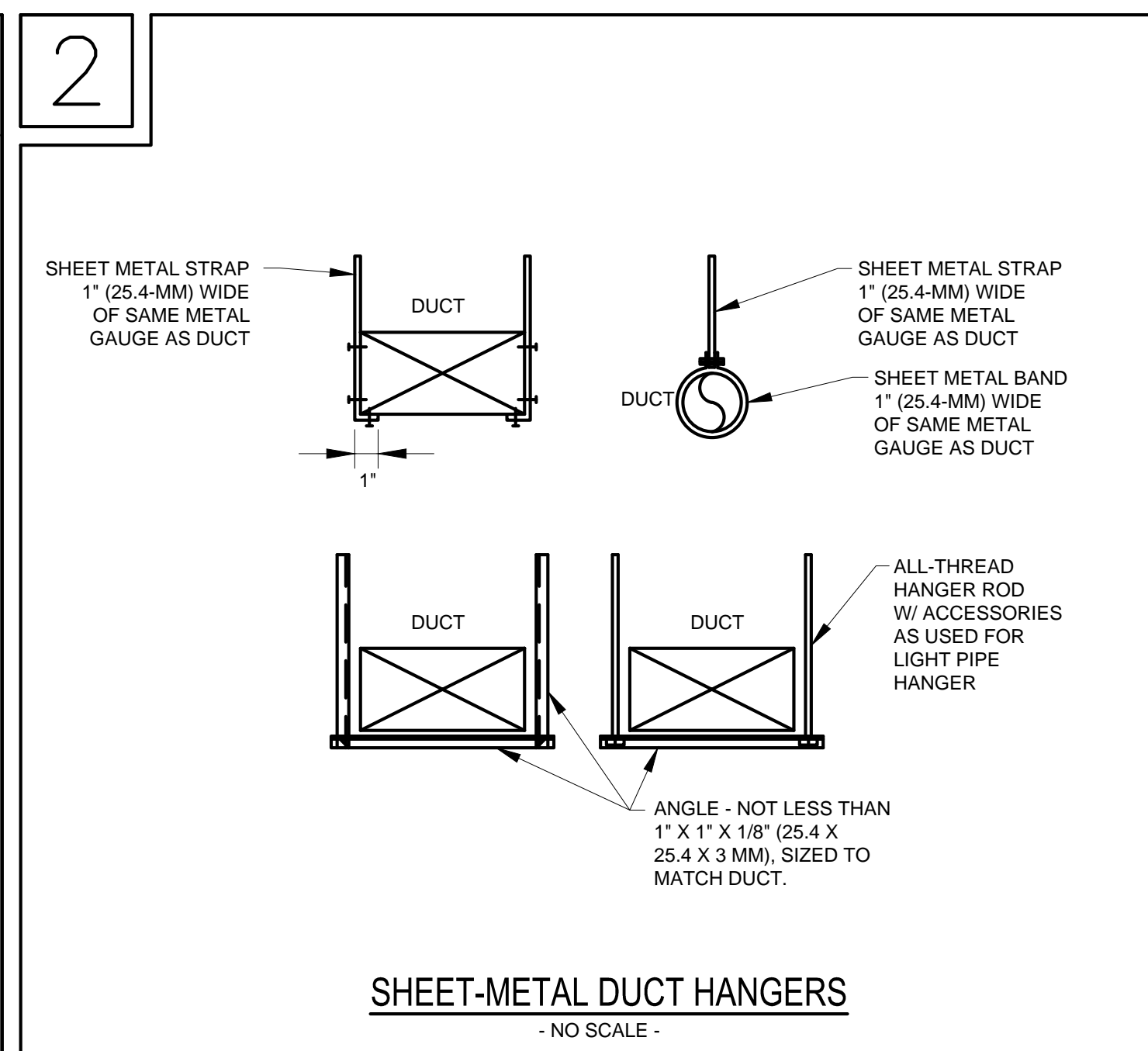
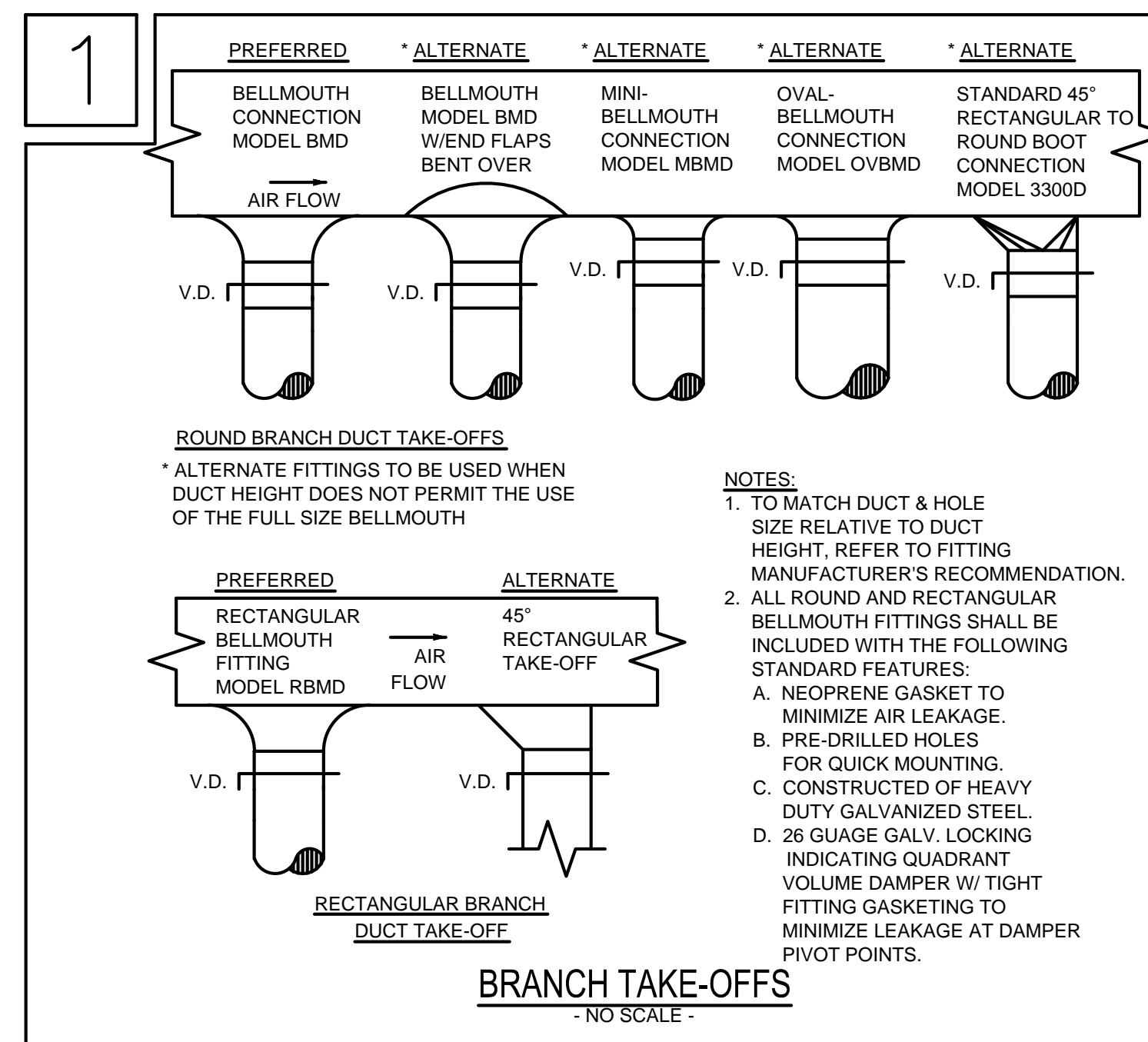
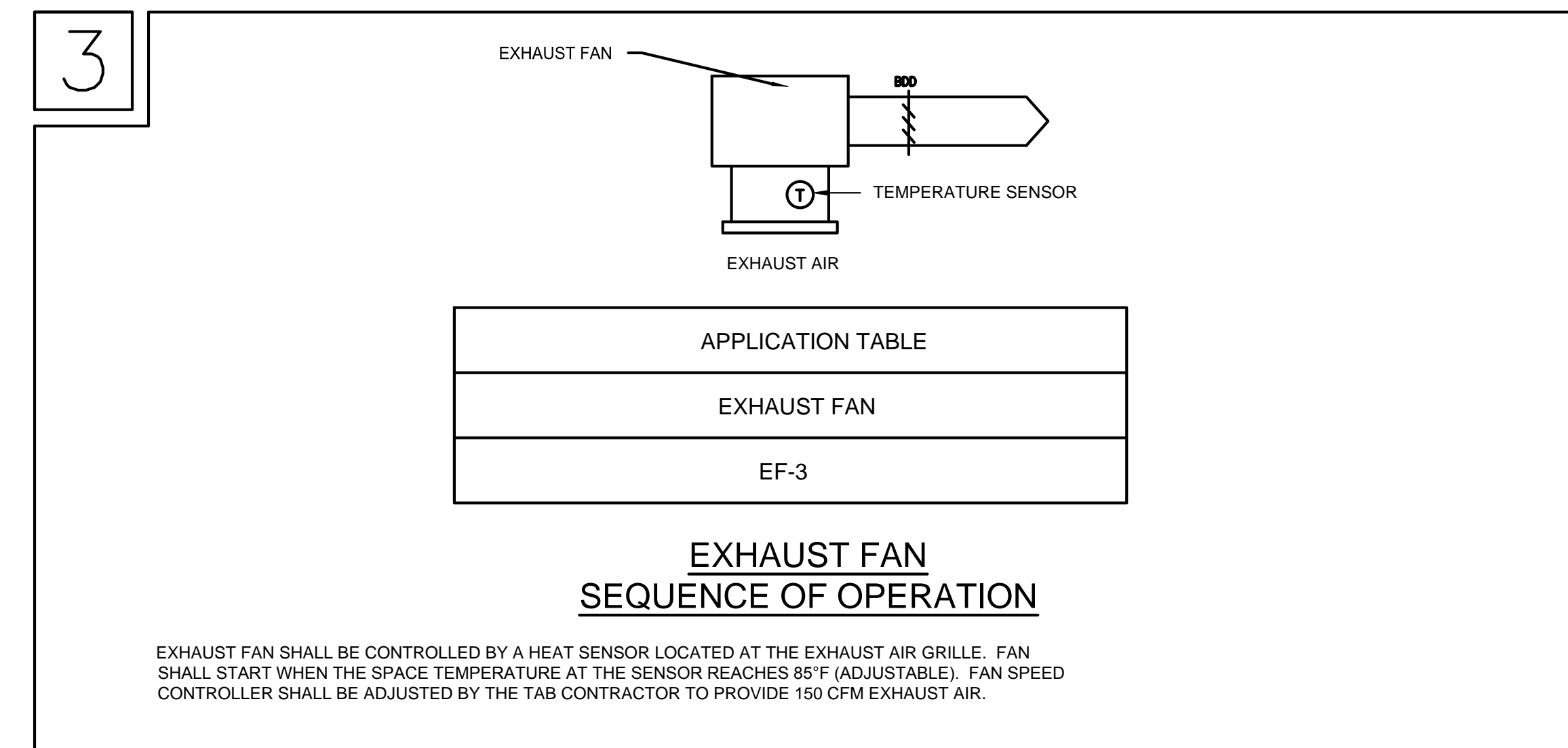
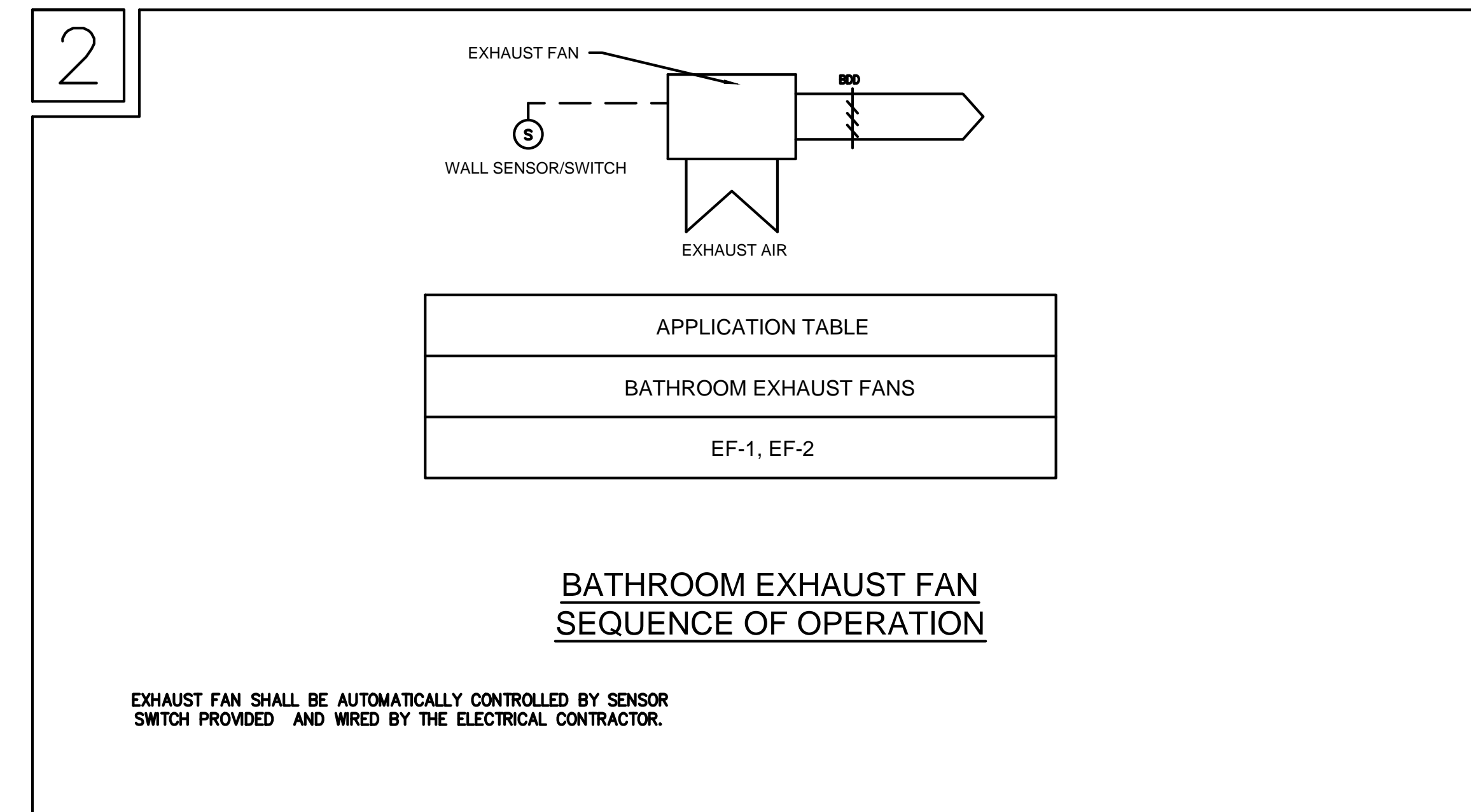
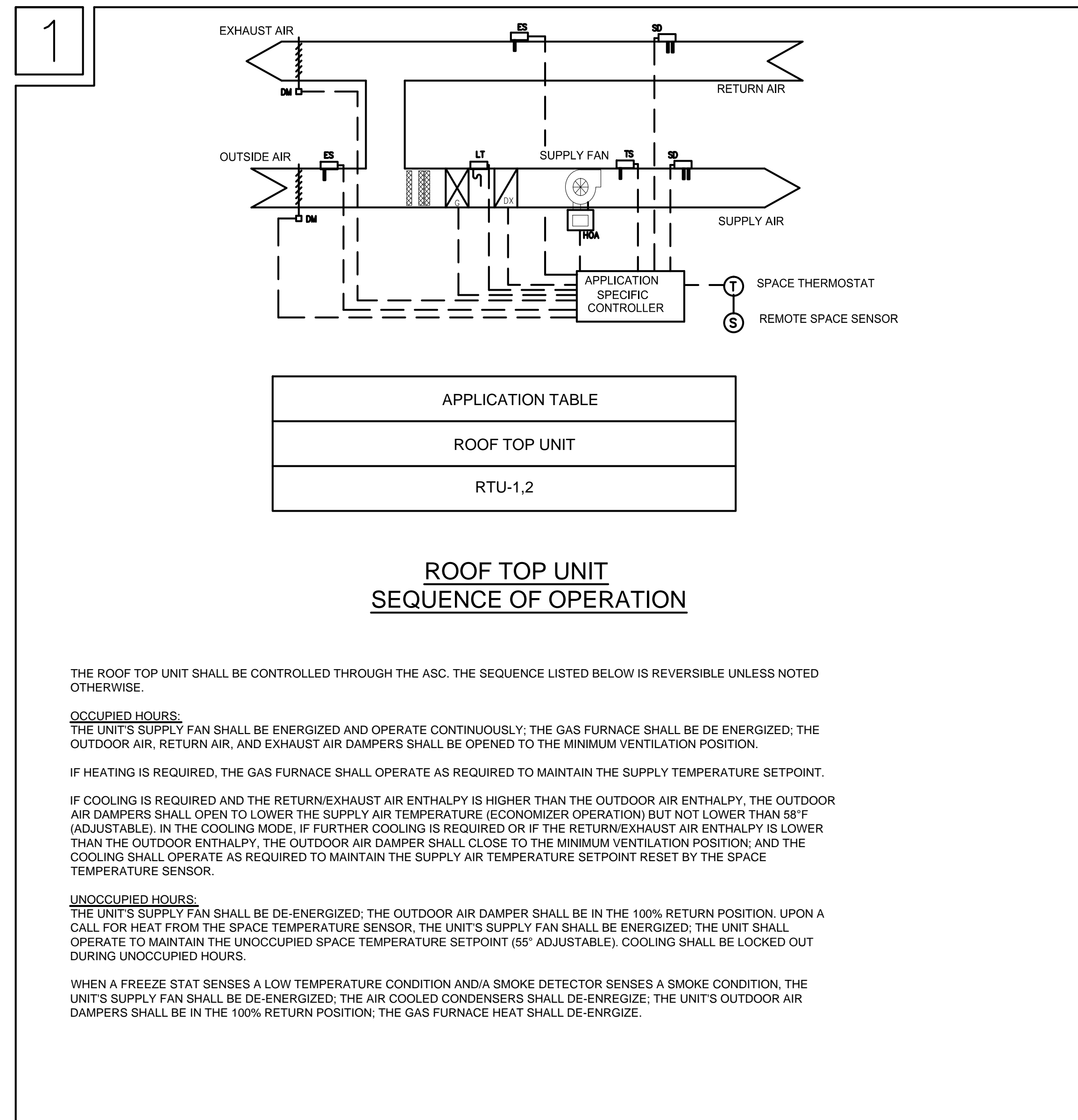

| No. | Date | Issued for |
|----------|------|----------------|
| 11/22/13 | | 90% Review Set |
| 01/24/14 | | Bid and Permit |

