

No.	Date	Issued for
-	11/22/13	90% CD Review Set
-	01/24/14	Bid & Permit

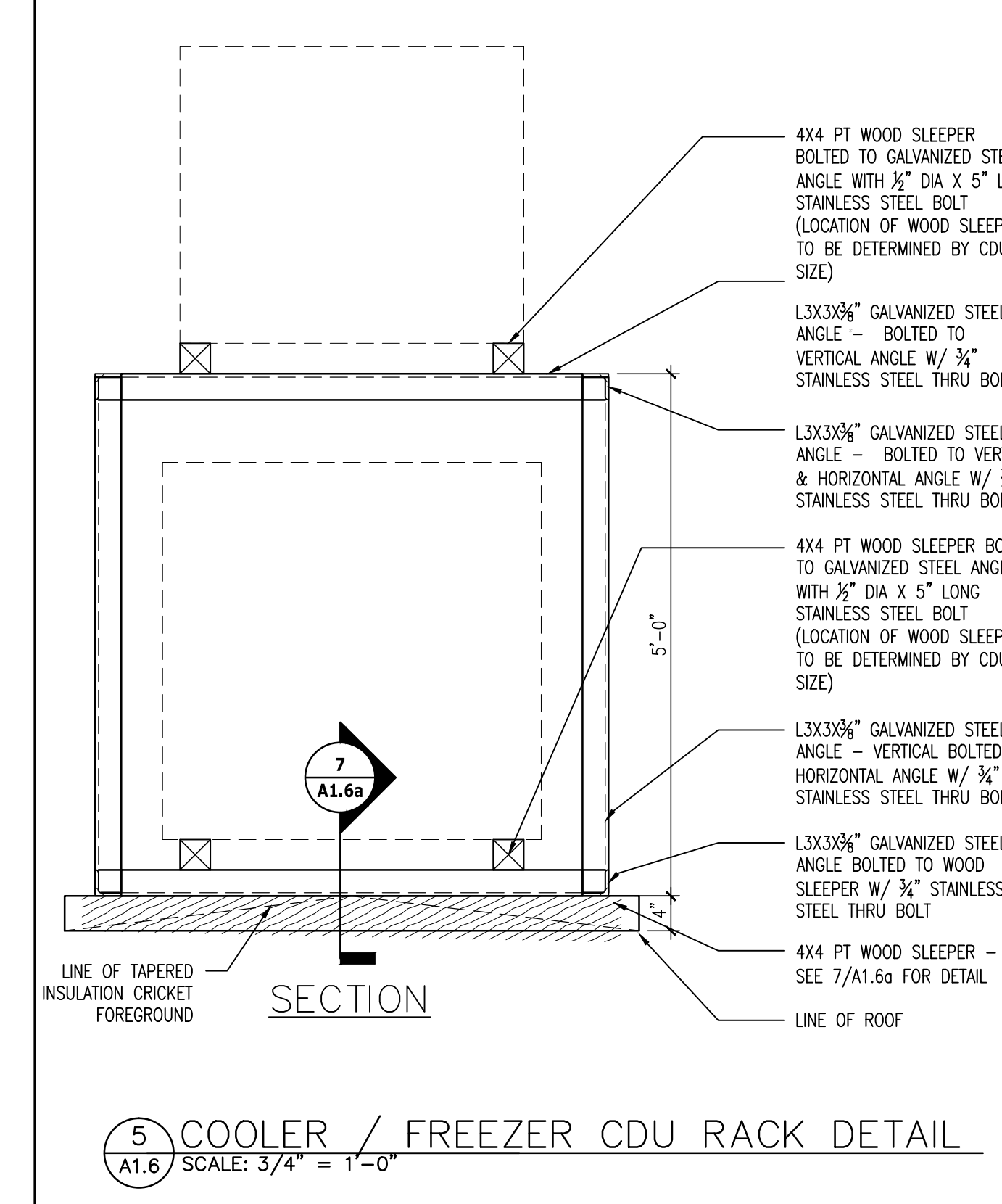

5 COOLER / FREEZER CDU RACK DETAIL
A1.6 SCALE: 3/4" = 1'-0"

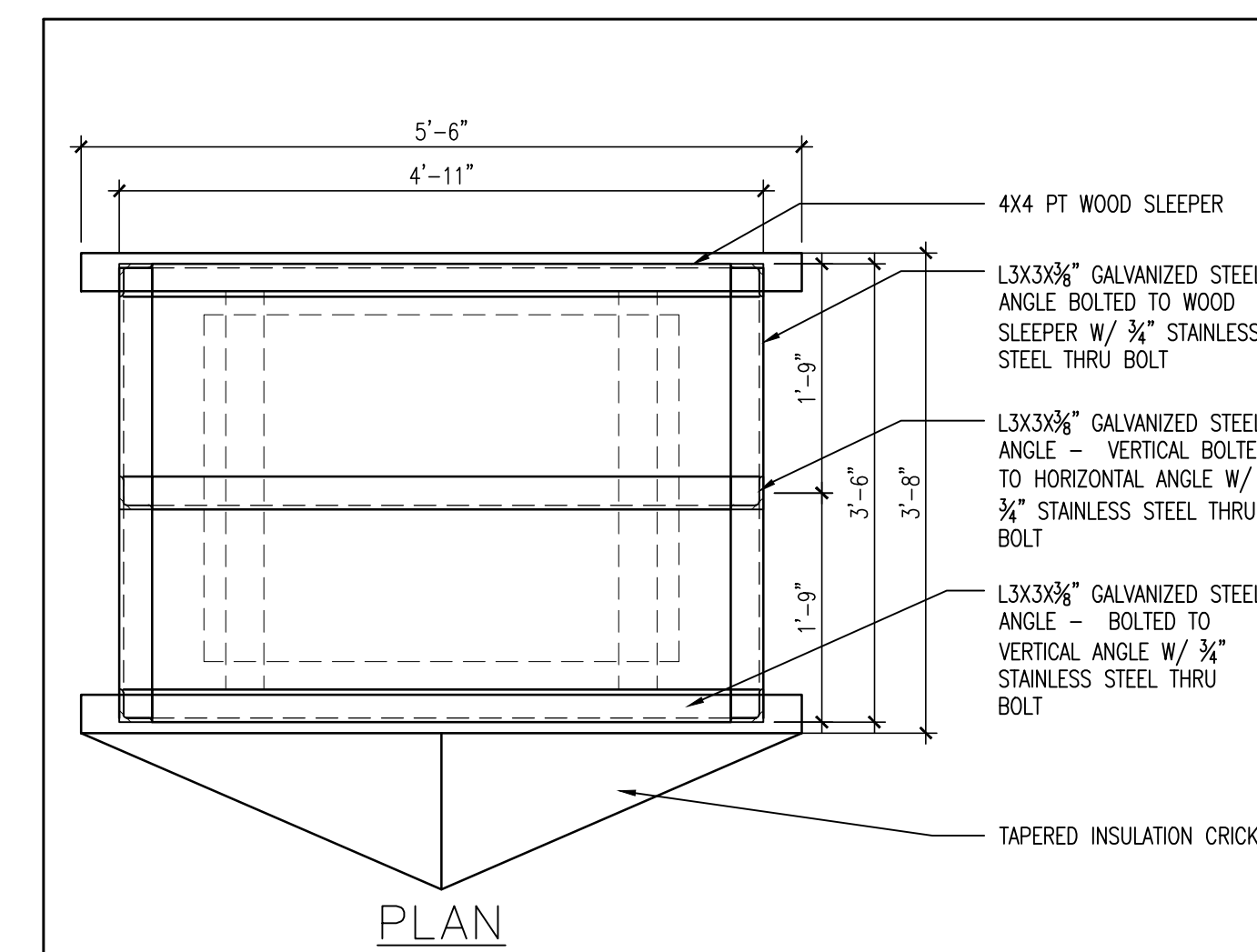
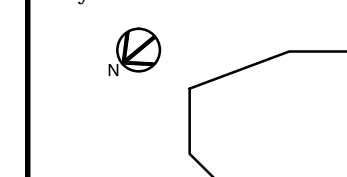
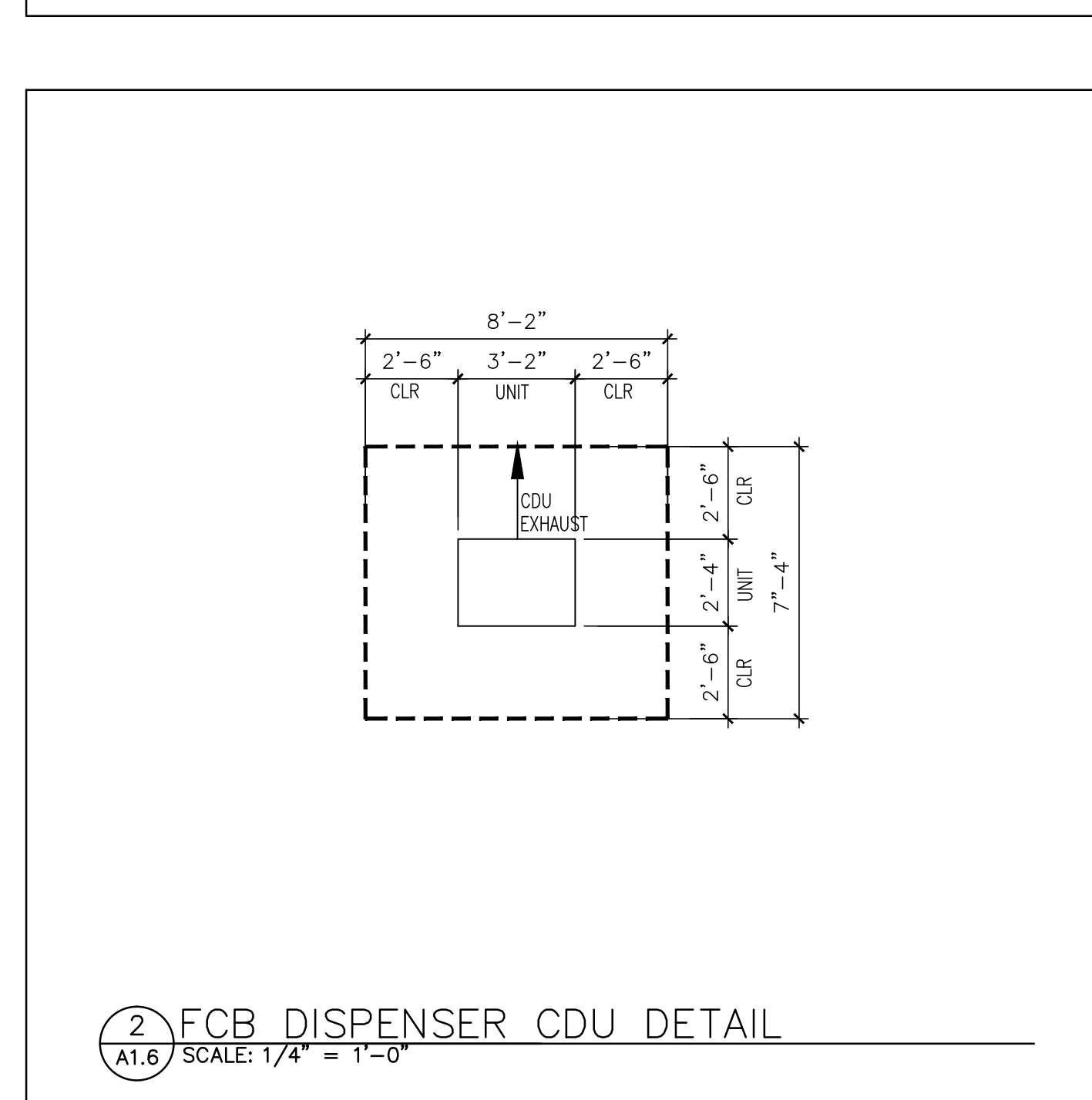
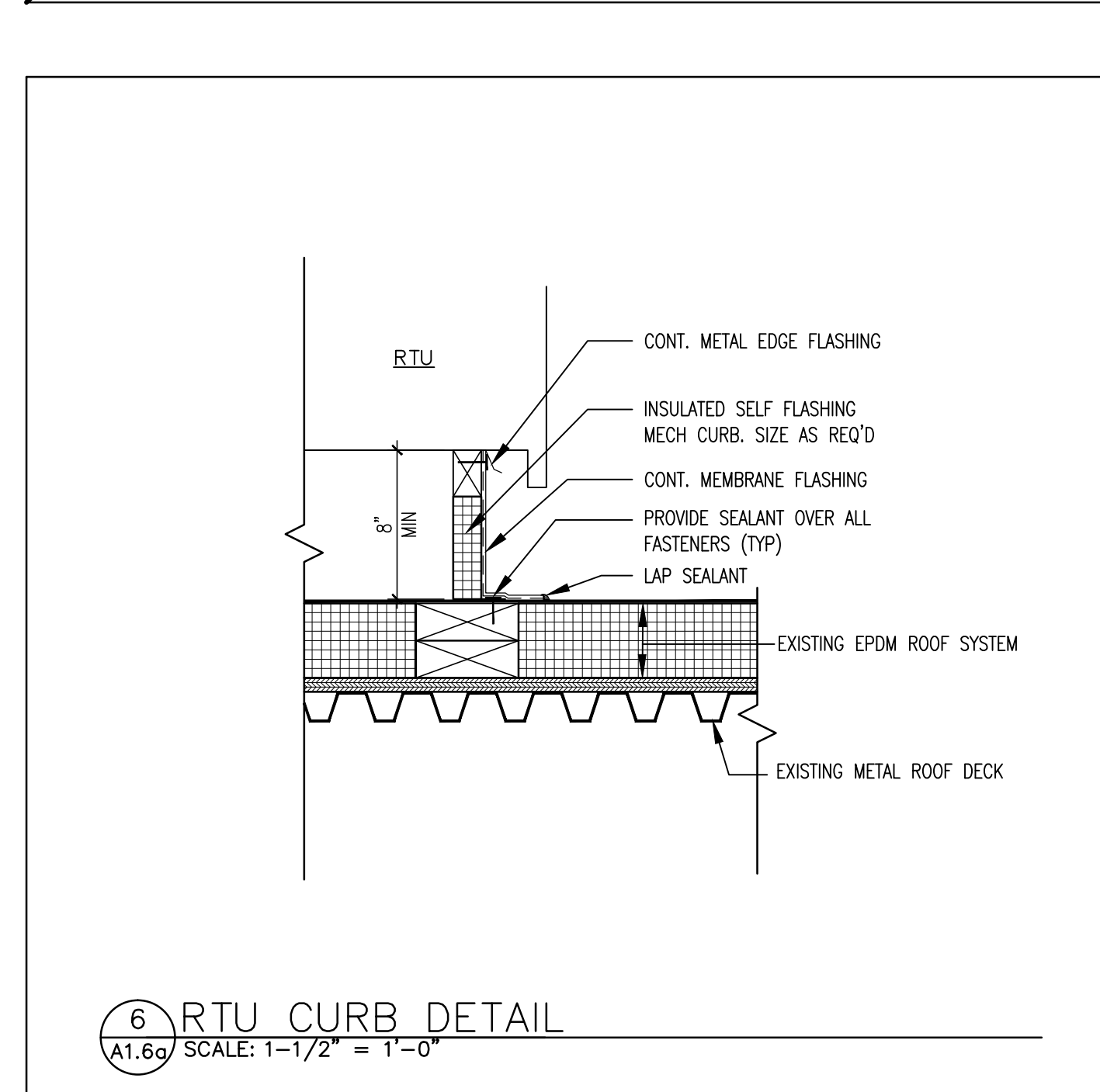
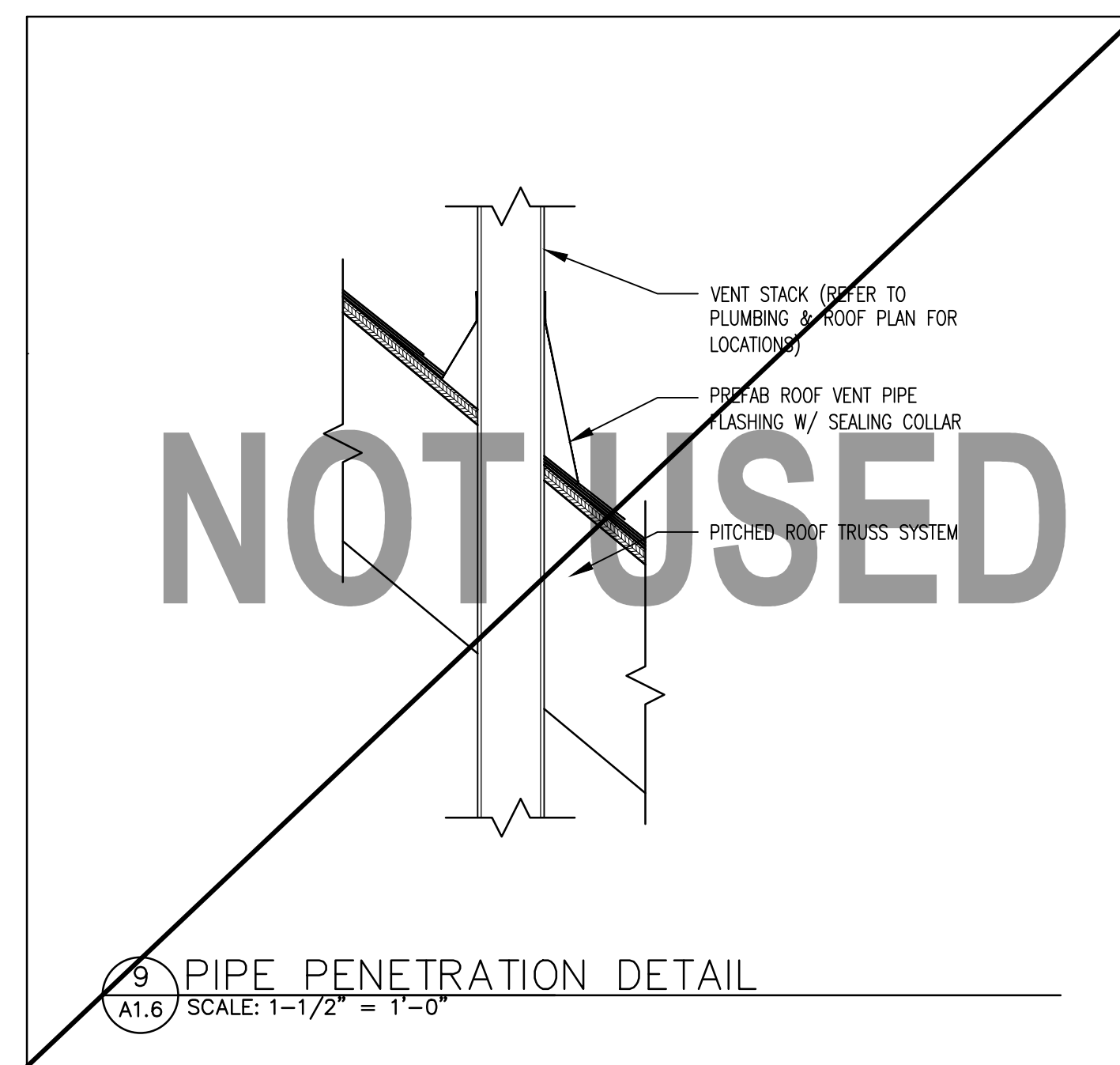

2 FCB DISPENSER CDU DETAIL
A1.6 SCALE: 1/4" = 1'-0"

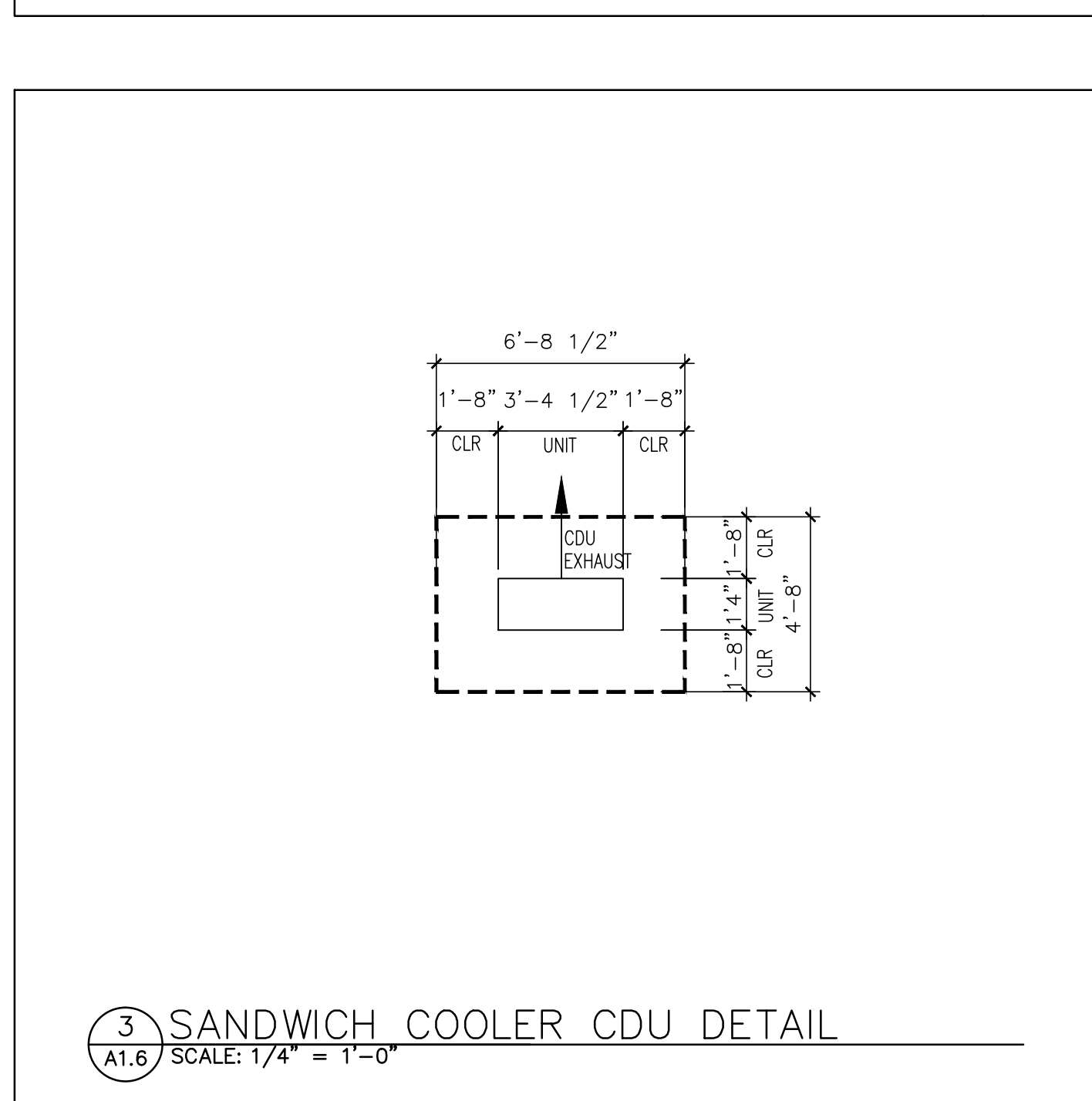
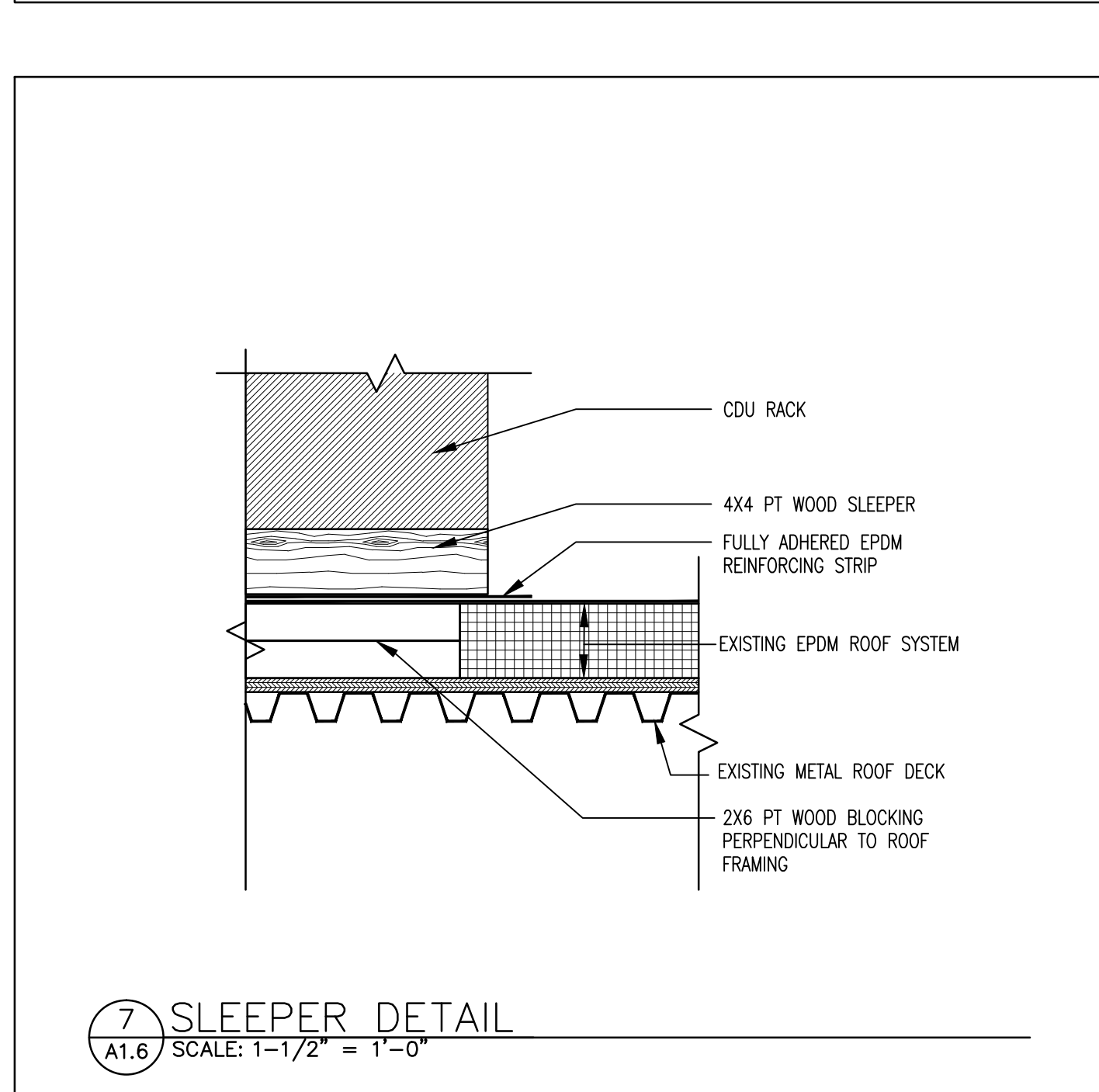
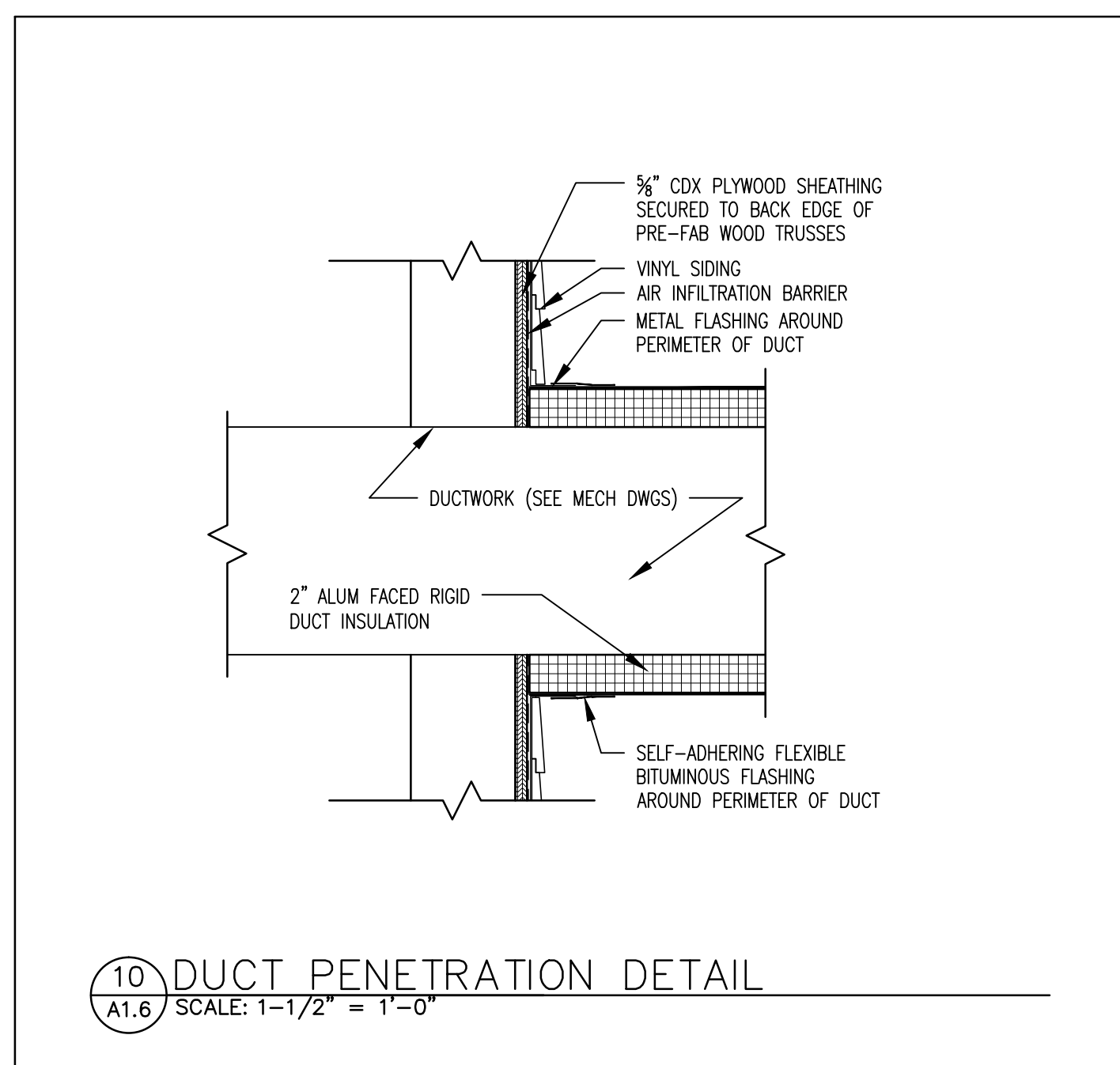

3 SANDWICH COOLER CDU DETAIL
A1.6 SCALE: 1/4" = 1'-0"

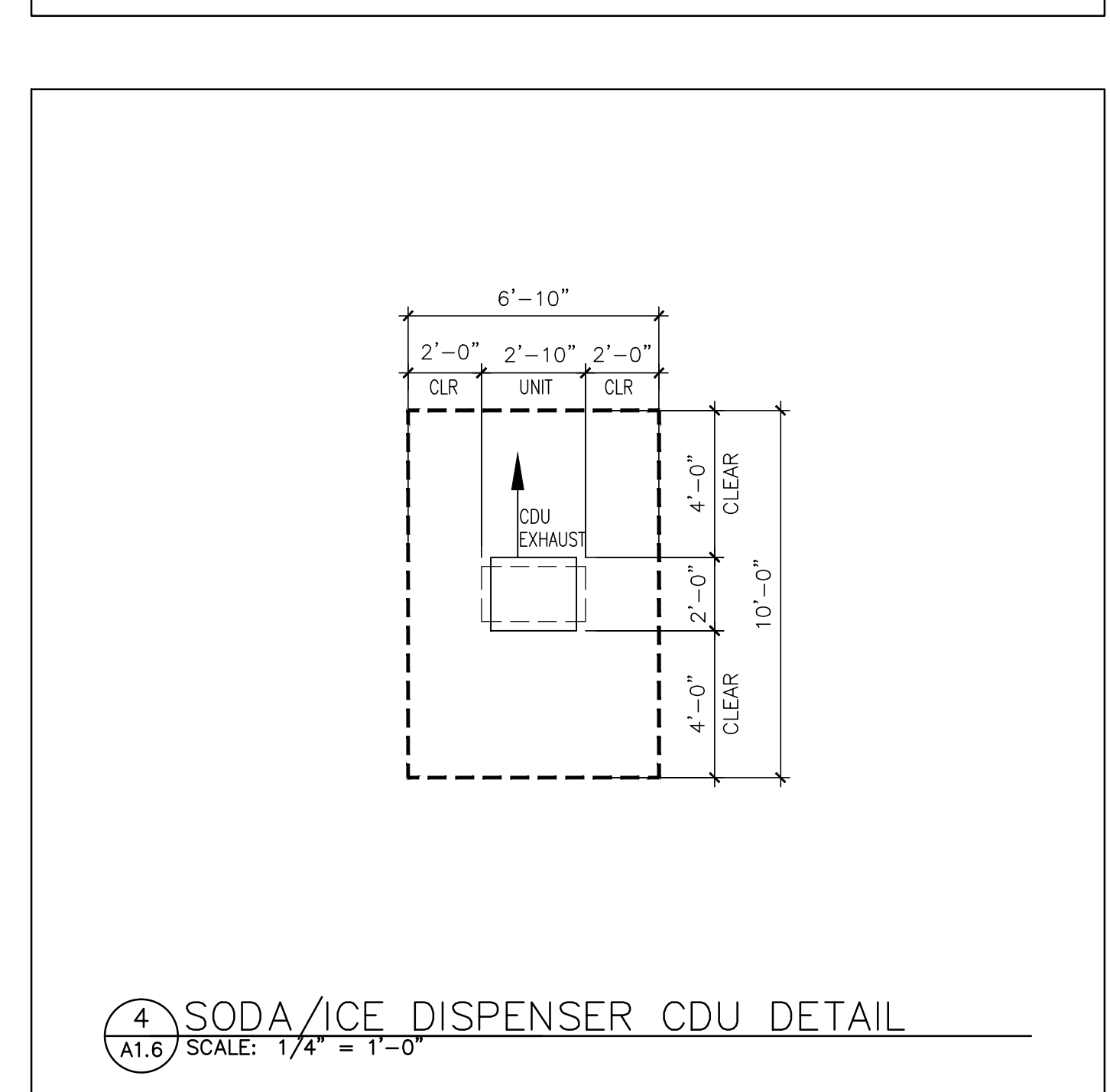
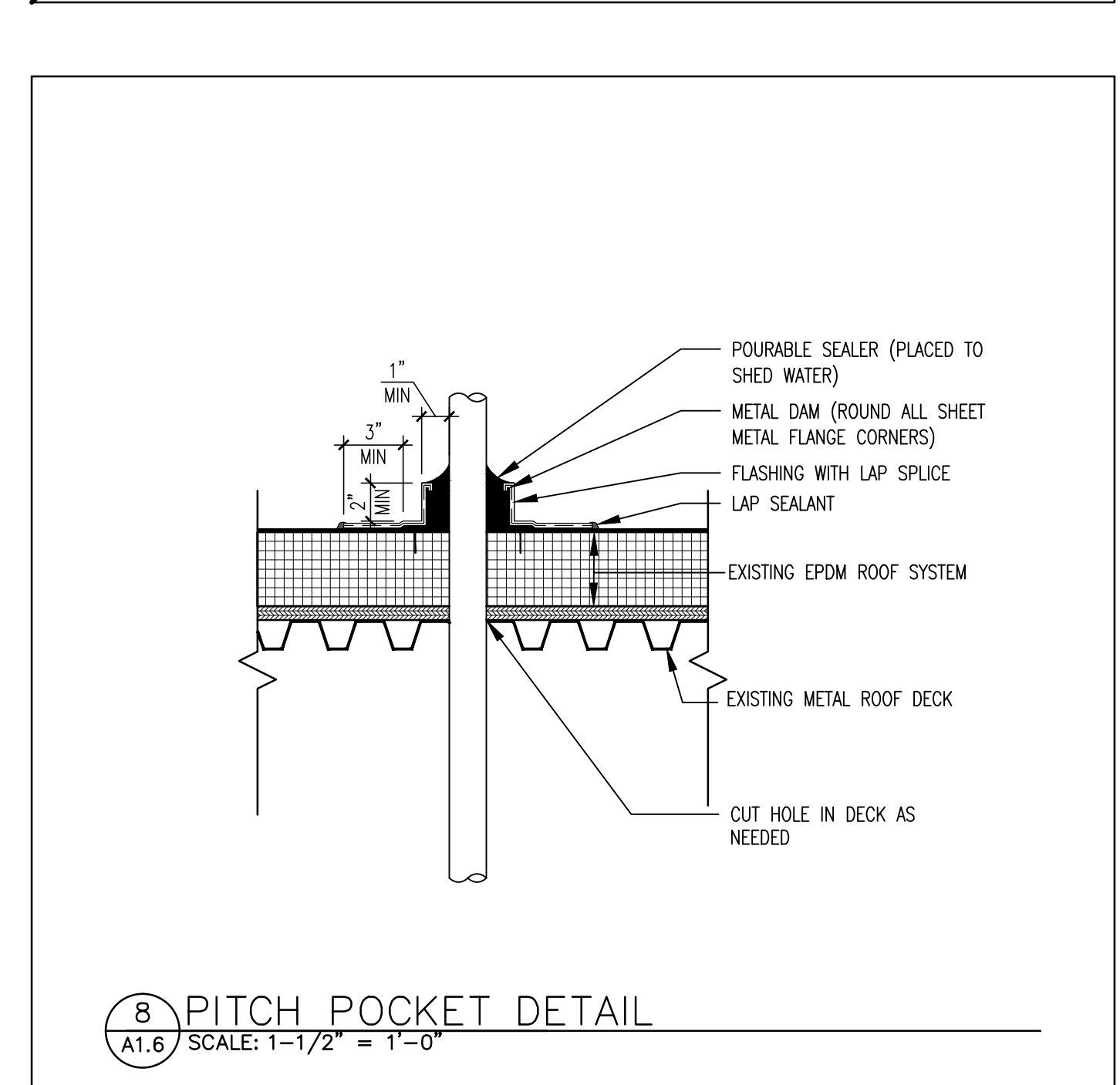
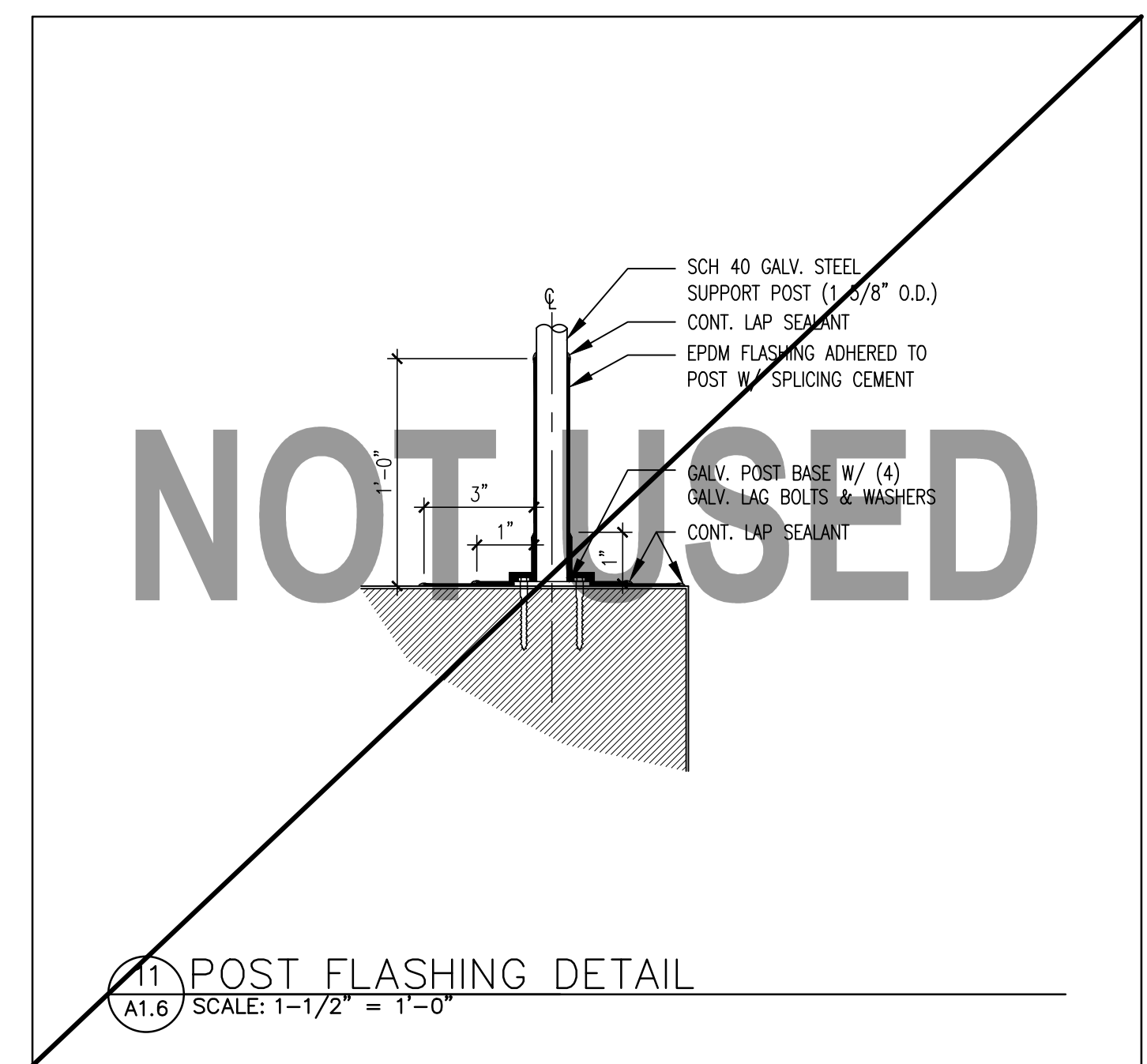

4 SODA/ICE DISPENSER CDU DETAIL
A1.6 SCALE: 1/4" = 1'-0"