

**Spugnardi Associates**

NEW DECK  
29 ALDEN CIRCLE, PORTLAND, MAINE

DATE: JUNE 22, 2006

BY: RBS

SCALE: AS NOTED

CDM

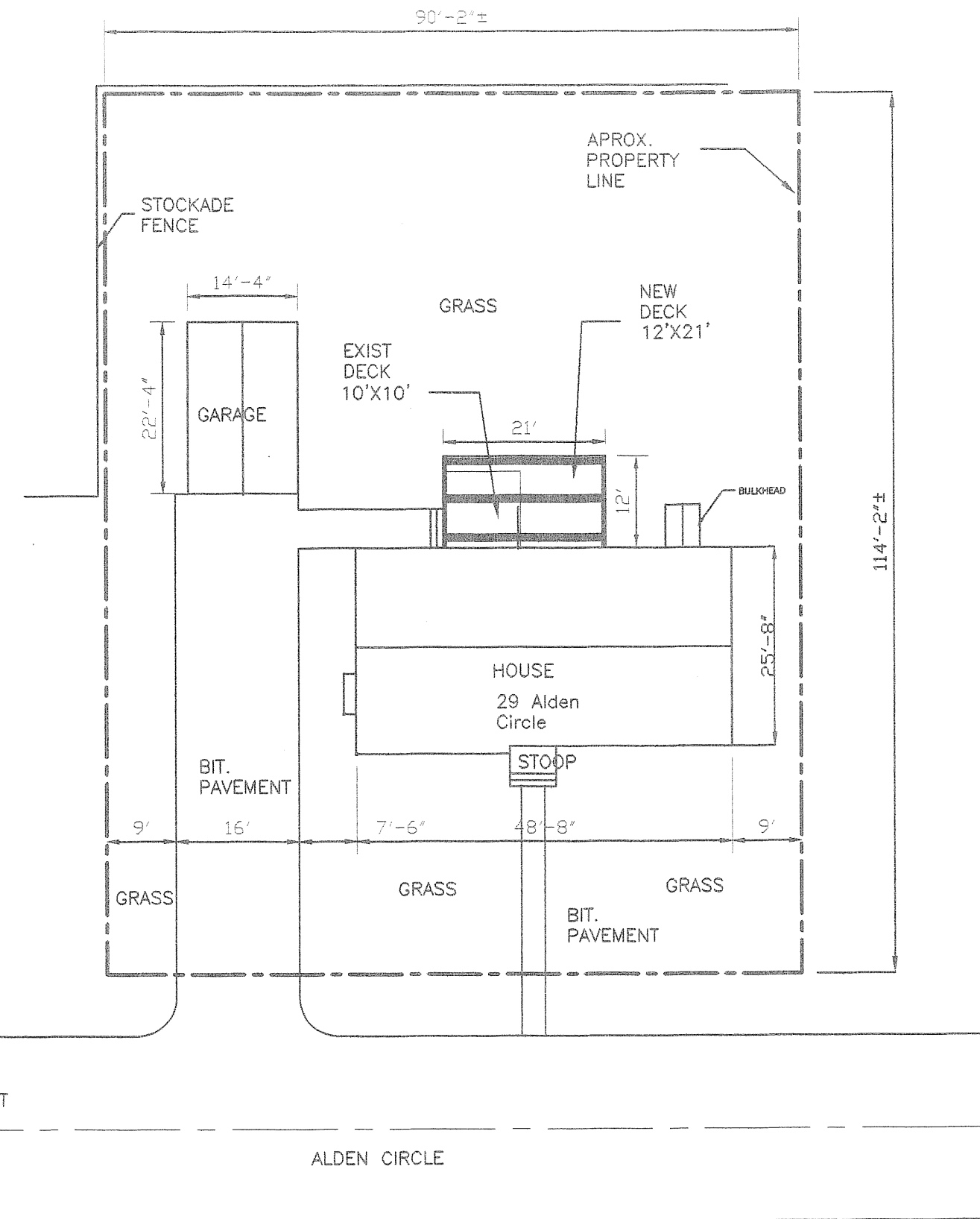

Scale: 1/16" = 1'-0"

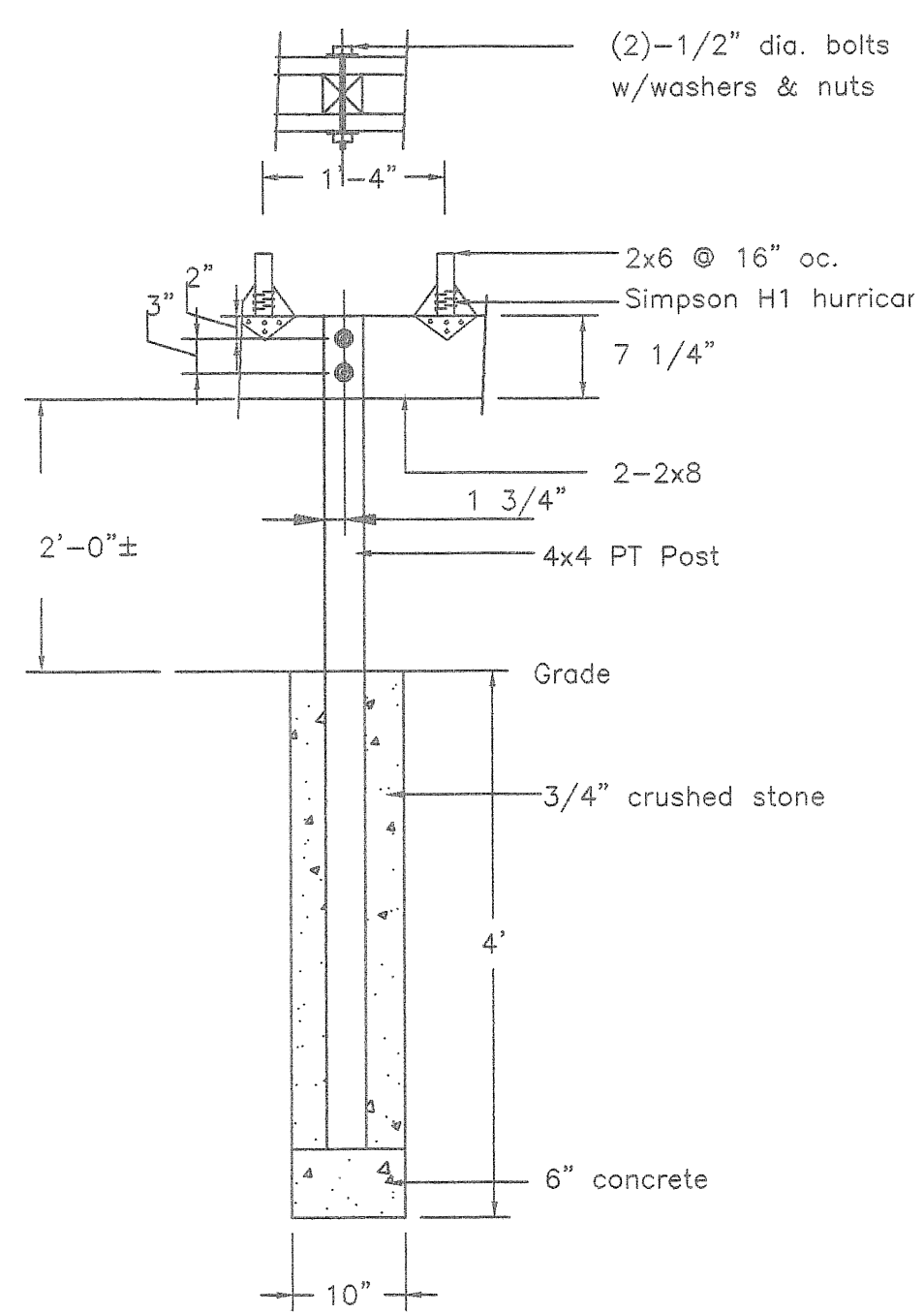
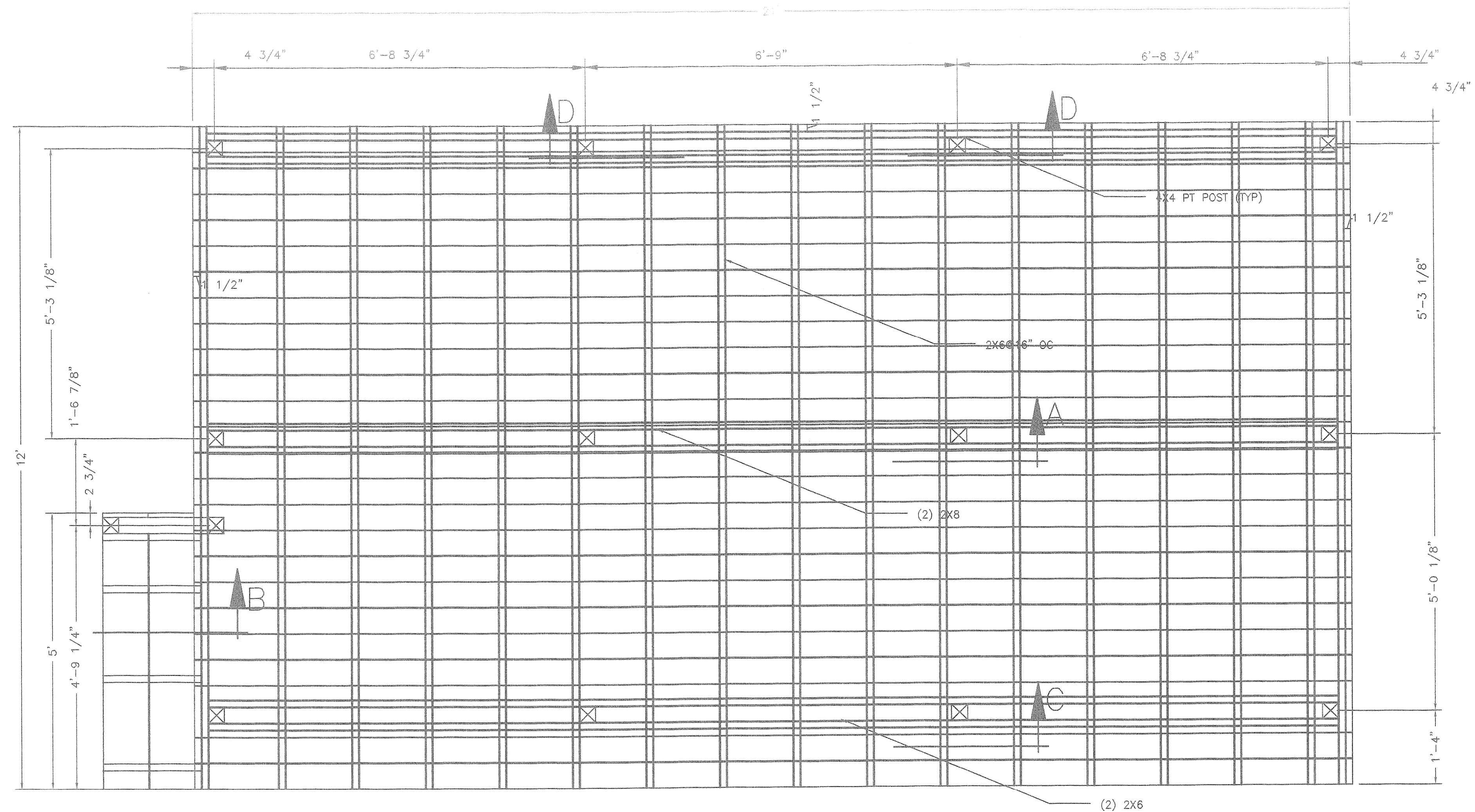

SECTION A  
Scale: 3/4" = 1'-0"

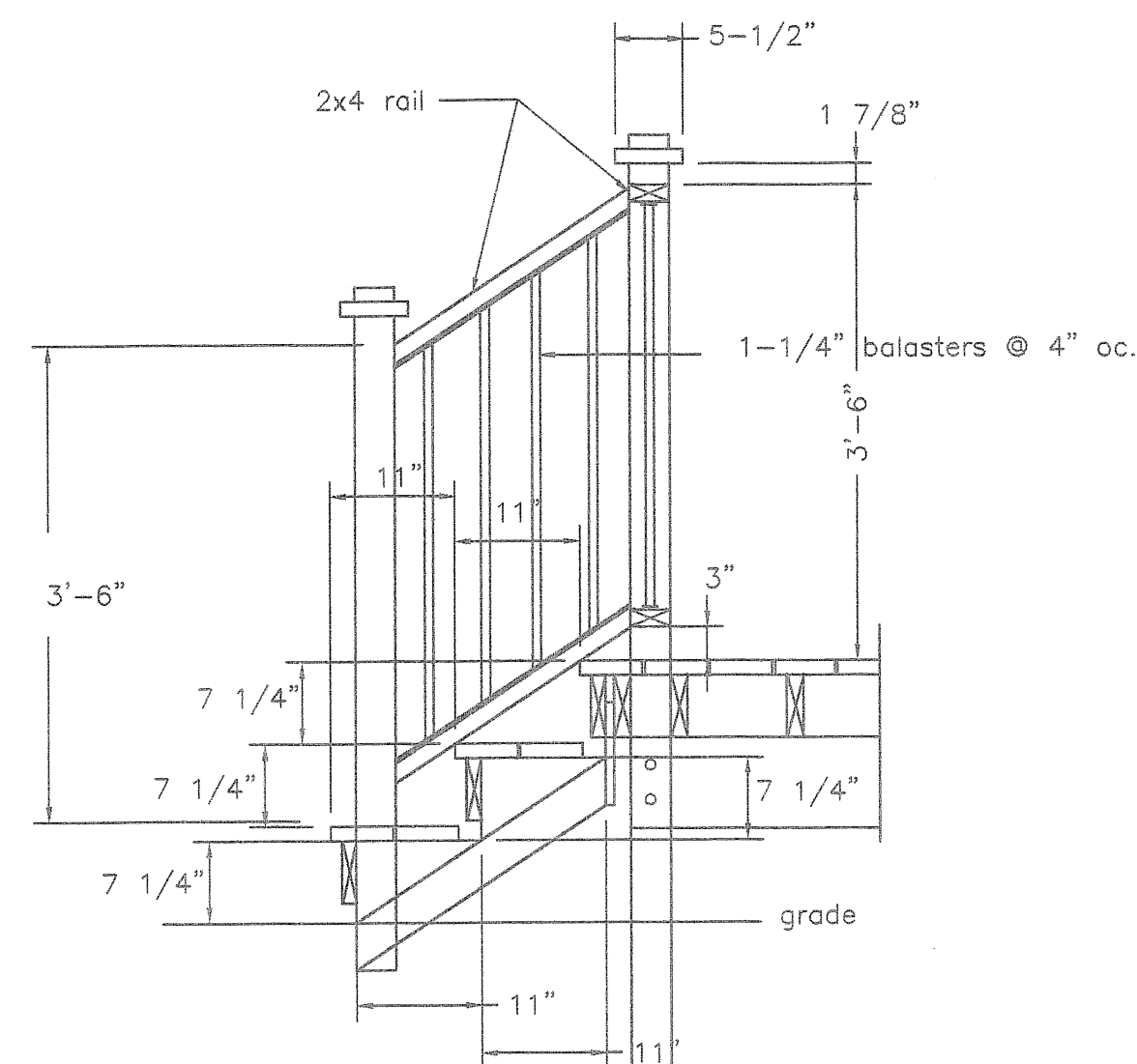

SECTION B  
Scale: 3/4" = 1'-0"

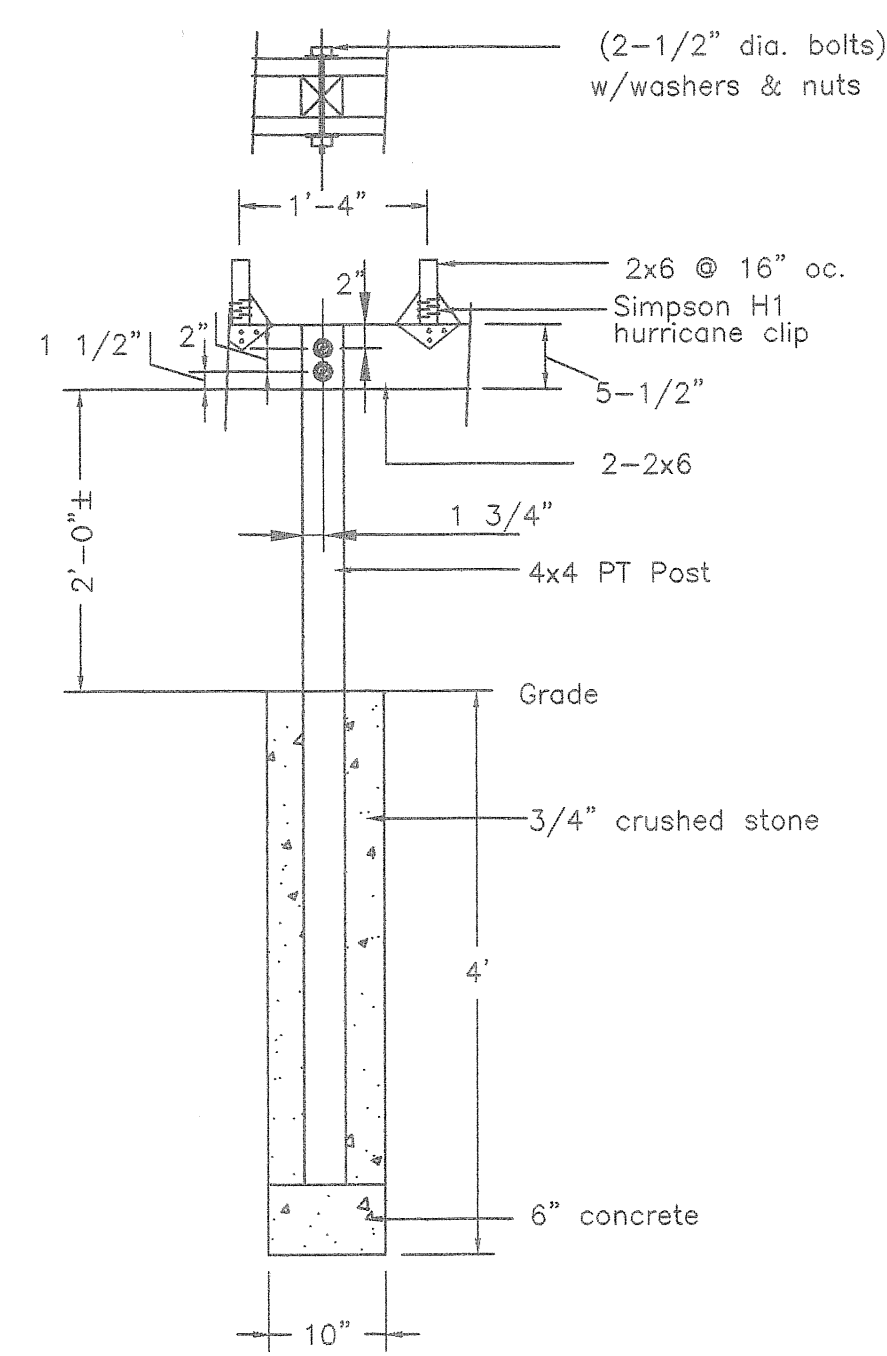

SECTION C  
Scale: 3/4" = 1'-0"

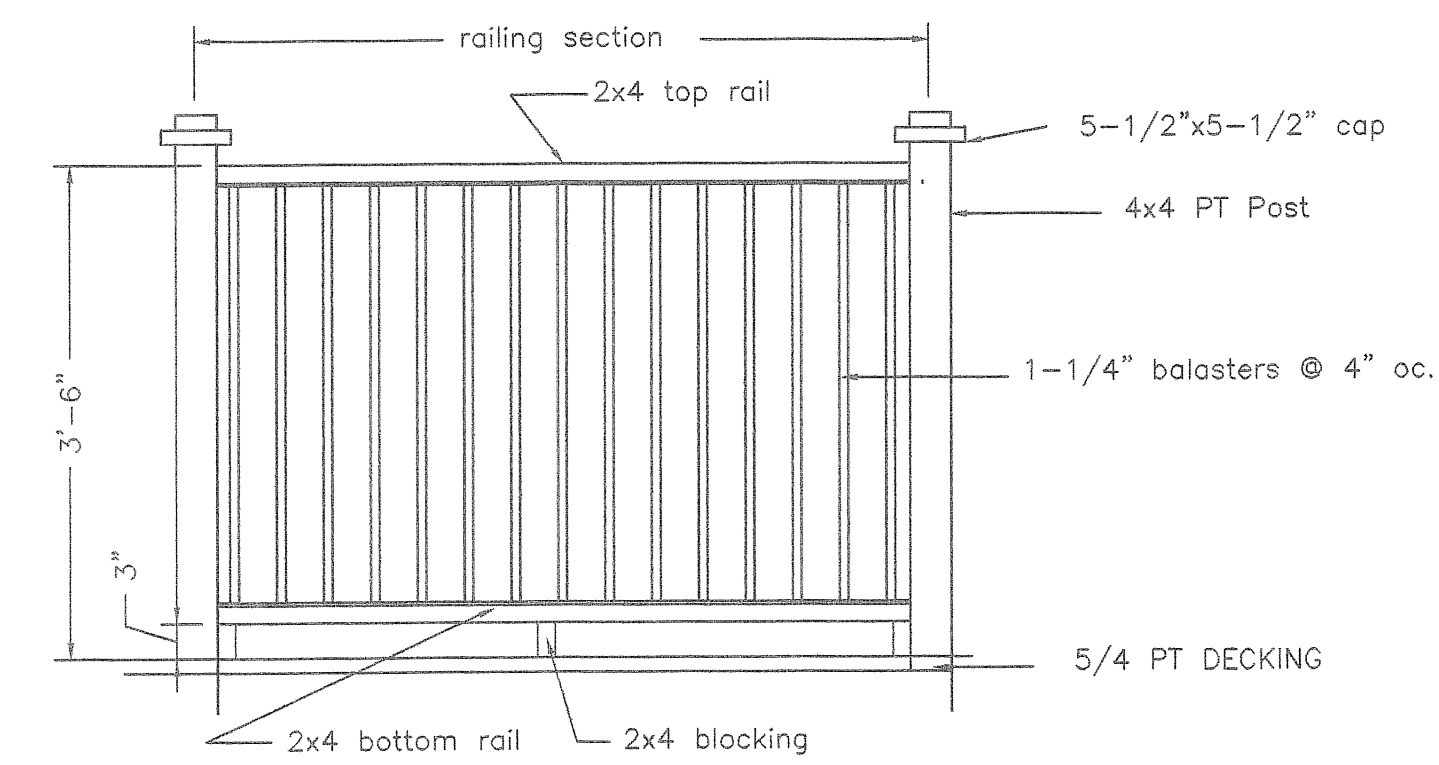

SECTION D  
Typical Railing Detail  
Scale: 3/4" = 1'-0"