

DISPLAY THIS CARD ON PRINCIPAL FRONTAGE OF WORK



CITY OF PORTLAND

BUILDING PERMIT

This is to certify that MICHAEL C HENSON

Located At 84 ALDEN CIR

Job ID: 2012-07-4478-ALTR

CBL: 182A- A-021-001

has permission to Changes for structure of deck

provided that the person or persons, firm or corporation accepting this permit shall comply with all of the provisions of the Statues of Maine and of the Ordinances of the City of Portland regulating the construction, maintenance and use of the buildings and structures, and of the application on file in the department.

Notification of inspection and written permission procured before this building or part thereof is lathed or otherwise closed-in. 48 HOUR NOTICE IS REQUIRED.

A final inspection must be completed by owner before this building or part thereof is occupied. If a certificate of occupancy is required, it must be

Fire Prevention Officer

Code Enforcement Officer / Plan Reviewer

**THIS CARD MUST BE POSTED ON THE STREET SIDE OF THE PROPERTY
PENALTY FOR REMOVING THIS CARD**

BUILDING PERMIT INSPECTION PROCEDURES

Please call 874-8703 or 874-8693 (ONLY)

or email: buildinginspections@portlandmaine.gov

With the issuance of this permit, the owner, builder or their designee is required to provide adequate notice to the city of Portland Inspections Services for the following inspections. Appointments must be requested 48 to 72 hours in advance of the required inspection. The inspection date will need to be confirmed by this office.

- **Please read the conditions of approval that is attached to this permit!! Contact this office if you have any questions.**
- **Permits expire in 6 months. If the project is not started or ceases for 6 months.**
- **If the inspection requirements are not followed as stated below additional fees may be incurred due to the issuance of a "Stop Work Order" and subsequent release to continue.**

Footings/Setbacks prior to pouring concrete

Close In Elec/Plmb/Frame prior to insulate or gyp

Final Inspection

The project cannot move to the next phase prior to the required inspection and approval to continue, REGARDLESS OF THE NOTICE OF CIRCUMSTANCES.

IF THE PERMIT REQUIRES A CERTIFICATE OF OCCUPANCY, IT MUST BE PAID FOR AND ISSUED TO THE OWNER OR DESIGNEE BEFORE THE SPACE MAY BE OCCUPIED.

City of Portland, Maine - Building or Use Permit Application

389 Congress Street, 04101 Tel: (207) 874-8703, FAX: (207) 8716

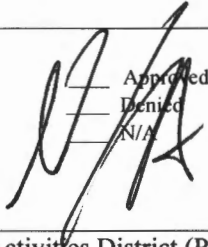
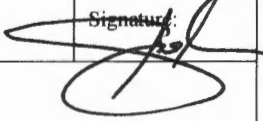
Job No: 2012-07-4478-ALTR 2012-47520-AMEND	Date Applied: 8/24/2012	CBL: 182A- A-021-001	
Location of Construction: 84 ALDEN CIR	Owner Name: MICHAEL HENSON & NICOLE HARKINS	Owner Address: 84 ALDEN CIR PORTLAND, ME 04102	Phone: 207-774-7404
Business Name:	Contractor Name: owner	Contractor Address:	Phone:
Lessee/Buyer's Name:	Phone:	Permit Type: BLDG - Building	Zone: R-3
Past Use: Single family	Proposed Use: Same – single family – amend permit 2012-07-4478 – structural changes to proposed deck	Cost of Work: 1000.00	CEO District:
		Fire Dept: <input checked="" type="checkbox"/> Approved <input type="checkbox"/> Denied <input type="checkbox"/> N/A	Inspection: Use Group: R-3 Type: SB IRC 09
		Signature: 	Signature: 
Proposed Project Description: amend #2012-074478 – structural changes to proposed deck		Pedestrian Activities District (P.A.D.)	
Permit Taken By: Brad		Zoning Approval	

<p>1. This permit application does not preclude the Applicant(s) from meeting applicable State and Federal Rules.</p> <p>2. Building Permits do not include plumbing, septic or electrical work.</p> <p>3. Building permits are void if work is not started within six (6) months of the date of issuance. False informatin may invalidate a building permit and stop all work.</p>	<p>Special Zone or Reviews</p> <p><input type="checkbox"/> Shoreland</p> <p><input type="checkbox"/> Wetlands</p> <p><input type="checkbox"/> Flood Zone</p> <p><input type="checkbox"/> Subdivision</p> <p><input type="checkbox"/> Site Plan</p> <p><input type="checkbox"/> Maj <input type="checkbox"/> Min <input type="checkbox"/> MM</p> <p>Date: OK 8/31/12 ABH</p>	<p>Zoning Appeal</p> <p><input type="checkbox"/> Variance</p> <p><input type="checkbox"/> Miscellaneous</p> <p><input type="checkbox"/> Conditional Use</p> <p><input type="checkbox"/> Interpretation</p> <p><input type="checkbox"/> Approved</p> <p><input type="checkbox"/> Denied</p> <p>Date:</p>	<p>Historic Preservation</p> <p><input checked="" type="checkbox"/> Not in Dist or Landmark</p> <p><input type="checkbox"/> Does not Require Review</p> <p><input type="checkbox"/> Requires Review</p> <p><input type="checkbox"/> Approved</p> <p><input type="checkbox"/> Approved w/Conditions</p> <p><input type="checkbox"/> Denied</p> <p>Date:</p>
	CERTIFICATION		

I hereby certify that I am the owner of record of the named property, or that the proposed work is authorized by the owner of record and that I have been authorized by the owner to make this application as his authorized agent and I agree to conform to all applicable laws of this jurisdiction. In addition, if a permit for work described in the application is issued, I certify that the code official's authorized representative shall have the authority to enter all areas covered by such permit at any reasonable hour to enforce the provision of the code(s) applicable to such permit.

SIGNATURE OF APPLICANT	ADDRESS	DATE	PHONE
RESPONSIBLE PERSON IN CHARGE OF WORK, TITLE		DATE	PHONE

R-3

child 47520

Entered 8/24/12

General Building Permit Application

(183)



If you or the property owner owes real estate or personal property taxes or user charges on any property within the City, payment arrangements must be made before permits of any kind are accepted.

Amend: ~~ID#~~ 2012-07-4478-ALTR

Location/Address of Construction: 84 Alden Cir Portland ME 04102		
Total Square Footage of Proposed Structure/Area	Square Footage of Lot	Number of Stories
Tax Assessor's Chart, Block & Lot Chart# Block# Lot# 182A A021	Applicant: (must be owner, lessee or buyer) Name Nicole Harkins & Michael Henson Address 84 Alden Cir City, State & Zip Portland ME 04102	Telephone: 207-774-7404
Lessee/DBA RECEIVED AUG 24 2012 Dept. of Building Inspections City of Portland Maine	Owner: (if different from applicant) Name Same Address City, State & Zip	Cost of Work: \$ _____ C of O Fee: \$ _____ Historic Review: \$ _____ Planning Amin.: \$ _____ Total Fee: \$ _____
Current legal use (i.e. single family) _____ Number of Residential Units _____ If vacant, what was the previous use? _____ Proposed Specific use: _____ Is property part of a subdivision? _____ If yes, please name _____ Project description: Change to existing permit for deck Amend Permit # 2012-07-4478-ALTR		
Contractor's name: Self		Email: nicole.harkins@gmail.com
Address: _____		Telephone: _____
City, State & Zip _____		Telephone: _____
Who should we contact when the permit is ready: Mike Henson		Telephone: _____
Mailing address: 84 Alden Cir		

Please submit all of the information outlined on the applicable checklist. Failure to do so will result in the automatic denial of your permit.

In order to be sure the City fully understands the full scope of the project, the Planning and Development Department may request additional information prior to the issuance of a permit. For further information or to download copies of this form and other applications visit the Inspections Division on-line at www.portlandmaine.gov, or stop by the Inspections Division office, room 315 City Hall or call 874-8703.

and I hereby certify that I am the Owner of record of the named property, or that the owner of record authorizes the proposed work and that I have been authorized by the owner to make this application as his/her authorized agent. I agree to conform to all applicable laws of this jurisdiction. In addition, if a permit for work described in this application is issued, I certify that the Code Official's authorized representative shall have the authority to enter all areas covered by this permit at any reasonable hour to enforce the provisions of the codes applicable to this permit.

Signature: Nicol Her Date: 8-24-12

This is not a permit; you may not commence ANY work until the permit is issued



PORTLAND MAINE

Strengthening a Remarkable City, Building a Community for Life • www.portlandmaine.gov

Receipts Details:

Tender Information: Check , Check Number: 356

Tender Amount: 30.00

Receipt Header:

Cashier Id: bsaucier

Receipt Date: 8/24/2012

Receipt Number: 47521

Receipt Details:

Referance ID:	7792	Fee Type:	BP-AMP
Receipt Number:	0	Payment Date:	
Transaction Amount:	30.00	Charge Amount:	30.00
Job ID: Job ID: 2012-07-4478-ALTR - remove deck & replace with wraparound deck			
Additional Comments: 84 Alden amend			

Thank You for your Payment!

Deck Plan Addendum

Michael Henson

84 Alden Circle, Portland, ME 04102

Beams will consist of two married 2x10 PT Yellow Pine boards mounted as follows:

Figure 8. Post-to-Beam Attachment Requirements

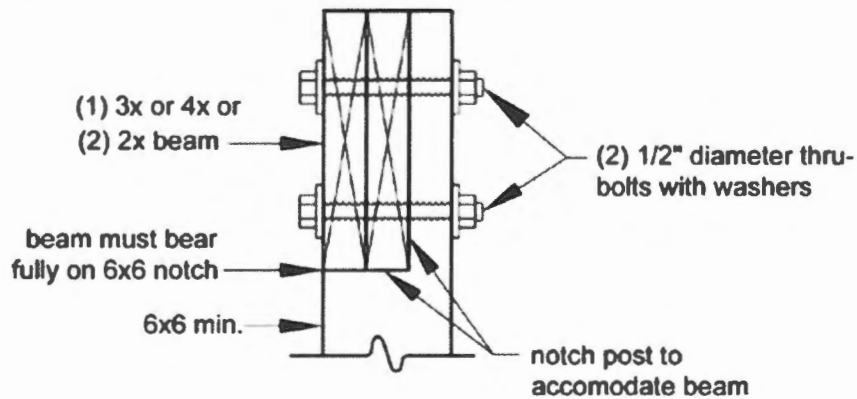

Holes for footings will be approximately 5' deep and 18" in diameter.

Footings will be 5' pre-cast concrete frost posts (see drawing)

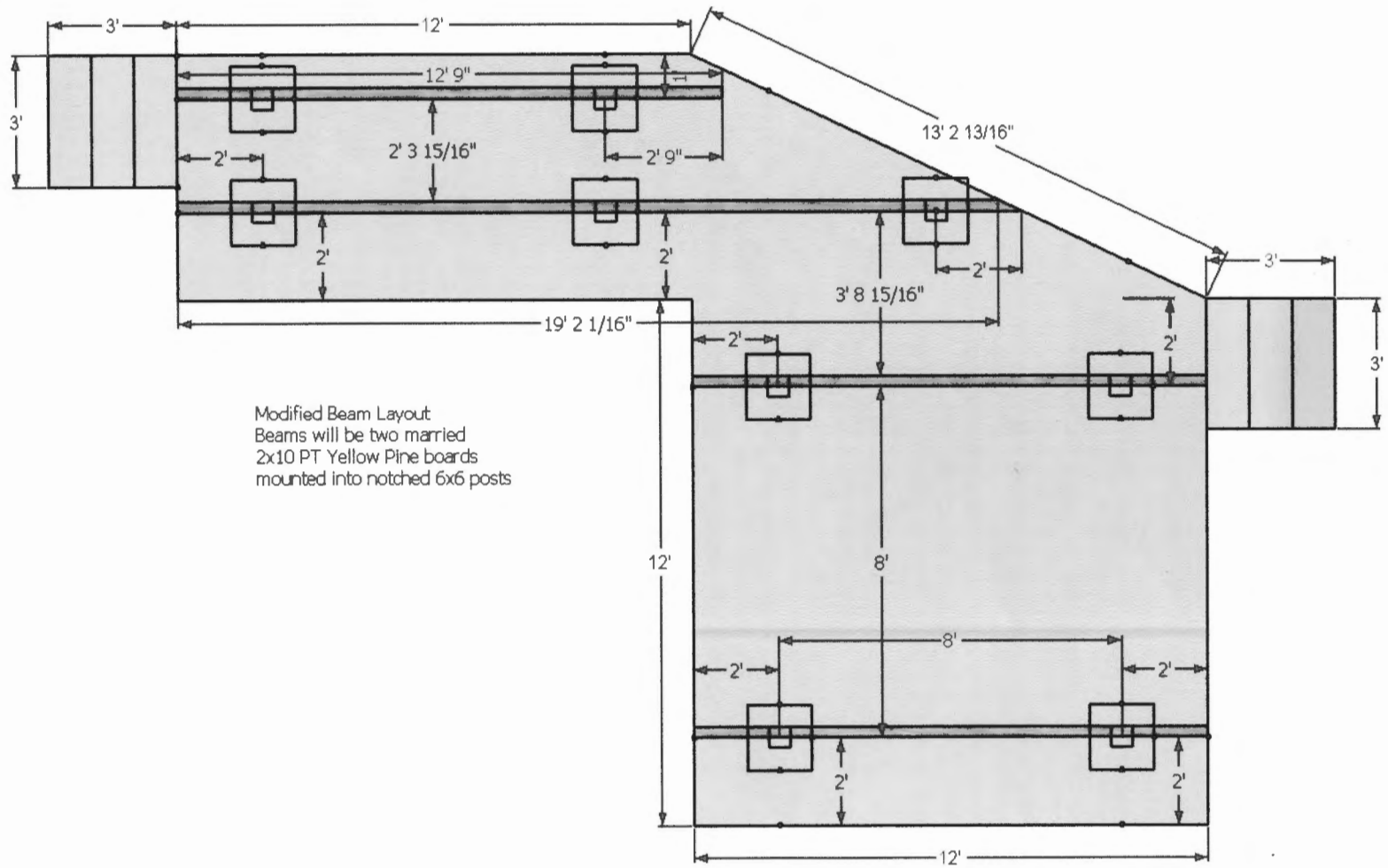

Modified Beam Layout
 Beams will be two married
 2x10 PT Yellow Pine boards
 mounted into notched 6x6 posts

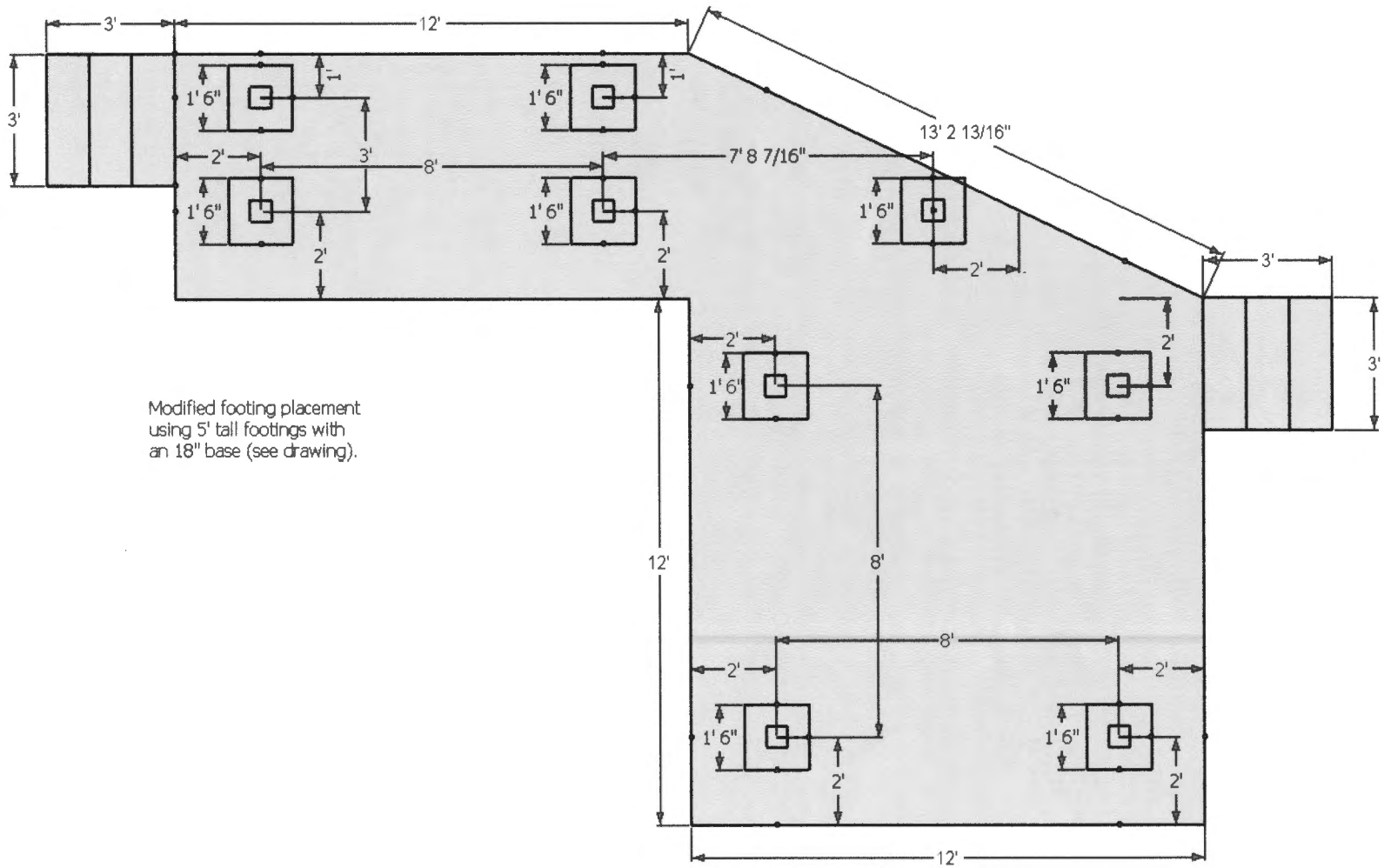

Modified footing placement
using 5' tall footings with
an 18" base (see drawing).

FROST POST

ITEM #F-102
WEIGHT - 390 LBS

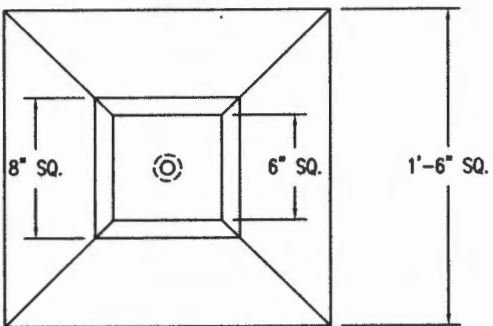

TOP VIEW

DESIGN NOTES:

- 1 - CONCRETE 4000 PSI AT 28 DAYS.
- 2 - REINFORCED WITH (2) - #4 BARS.
- 3 - 1/2" x 2 3/4" THREADED INSERT CAST IN TOP.

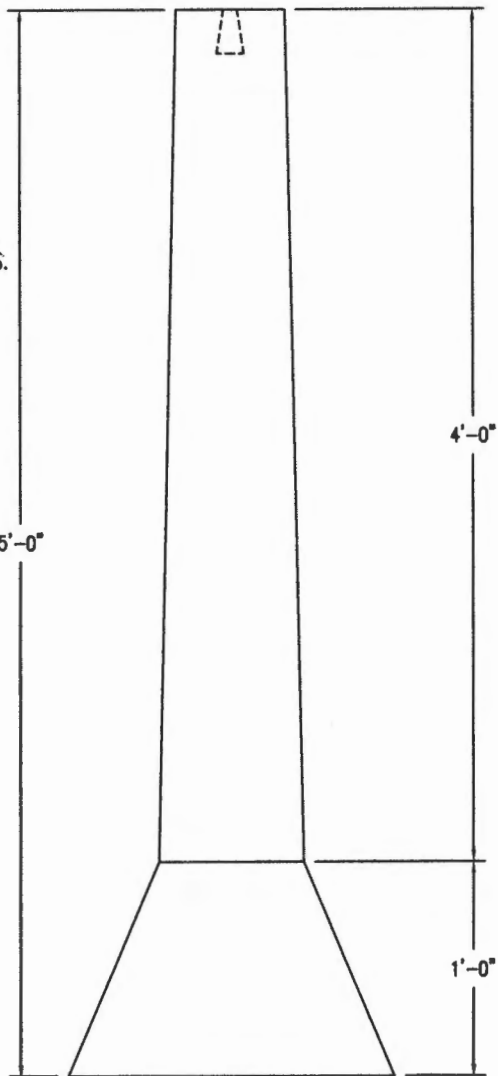

FRONT VIEW