

**DISPLAY THIS CARD ON PRINCIPAL FRONTAGE OF WORK**  
**CITY OF PORTLAND**

Please Read  
Application And  
Notes, If Any,  
Attached

**BUILDING INSPECTION**

**PERMIT**

Permit Number: **080748**

This is to certify that WEIGEL ANNE D & JOHN KWOKA ITS/Ken Stover

has permission to Demolish Single car garage

AT 92 HAMBLET AVE

PL 179-3040001

JUL 16 2003

CITY OF PORTLAND

provided that the person or persons who apply for or accept this permit shall comply with all of the provisions of the Statutes of the State and of the Ordinances of the City of Portland regulating the construction, maintenance and use of buildings and structures, and of the application on file in this department.

Apply to Public Works for street line and grade if nature of work requires such information.

Notification of inspection must be given and when permission is procured before this building or part thereof is leased or otherwise closed-in. 24 HOUR NOTICE IS REQUIRED.

A certificate of occupancy must be procured by owner before this building or part thereof is occupied.

**OTHER REQUIRED APPROVALS**

Fire Dept. \_\_\_\_\_

Health Dept. \_\_\_\_\_

Appeal Board \_\_\_\_\_

Other \_\_\_\_\_

Department Name

Director - Building & Inspection Services

**PENALTY FOR REMOVING THIS CARD**

*Christy A. [Signature]* 7/7/03

**City of Portland, Maine - Building or Use Permit Application**

389 Congress Street, 04101 Tel: (207) 874-8703, Fax: (207) 874-8716

Permit No: 08-0748	Issue Date: 7/7/08	CBL: 179 B040001 41
-----------------------	-----------------------	------------------------

Location of Construction: 92 HAMBLET AVE	Owner Name: WEIGEL ANNE D & JOHN J KW	Owner Address: 92 HAMBLET AVE	Phone:
Business Name:	Contractor Name: Ken Stover	Contractor Address: 4 Harrison Road Bridgton	Phone:
Lessee/Buyer's Name	Phone:	Permit Type: Demolitions - Building	Zone: R-3

Past Use: Single Family Home	Proposed Use: Single Family Home - Demolish Single car garage	Permit Fee: \$40.00	Cost of Work: \$2,000.00	CEO District: 5
Proposed Project Description: Demolish Single car garage		FIRE DEPT: <input type="checkbox"/> Approved <input type="checkbox"/> Denied	INSPECTION: Use Group: R-3 Type: SB IRL-2003 Signature: 7/7/08 [Signature]	
		PEDESTRIAN ACTIVITIES DISTRICT (P.A.D.) Action: <input type="checkbox"/> Approved <input type="checkbox"/> Approved w/Conditions <input type="checkbox"/> Denied Signature: Date:		

Permit Taken By: Idobson	Date Applied For: 06/24/2008	<b>Zoning Approval</b>
-----------------------------	---------------------------------	------------------------

<ol style="list-style-type: none"> <li>This permit application does not preclude the Applicant(s) from meeting applicable State and Federal Rules.</li> <li>Building permits do not include plumbing, septic or electrical work.</li> <li>Building permits are void if work is not started within six (6) months of the date of issuance. False information may invalidate a building permit and stop all work..</li> </ol>	<b>Special Zone or Reviews</b> <input type="checkbox"/> Shoreland <input type="checkbox"/> Wetland <input type="checkbox"/> Flood Zone <input type="checkbox"/> Subdivision <input type="checkbox"/> Site Plan Maj <input type="checkbox"/> Minor <input type="checkbox"/> MM <input type="checkbox"/> OK w/condition Date: 7/1/08 ABM	<b>Zoning Appeal</b> <input type="checkbox"/> Variance <input type="checkbox"/> Miscellaneous <input type="checkbox"/> Conditional Use <input type="checkbox"/> Interpretation <input type="checkbox"/> Approved <input type="checkbox"/> Denied Date:	<b>Historic Preservation</b> <input checked="" type="checkbox"/> Not in District or Landmark <input type="checkbox"/> Does Not Require Review <input type="checkbox"/> Requires Review <input type="checkbox"/> Approved <input type="checkbox"/> Approved w/Conditions <input type="checkbox"/> Denied Date: ABM
---	--	---	--

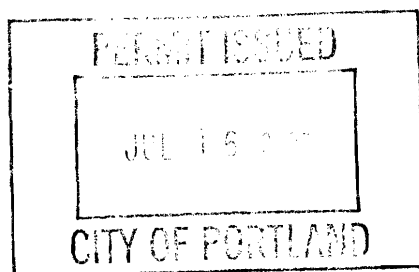

**CERTIFICATION**

I hereby certify that I am the owner of record of the named property, or that the proposed work is authorized by the owner of record and that I have been authorized by the owner to make this application as his authorized agent and I agree to conform to all applicable laws of this jurisdiction. In addition, if a permit for work described in the application is issued, I certify that the code official's authorized representative shall have the authority to enter all areas covered by such permit at any reasonable hour to enforce the provision of the code(s) applicable to such permit.

SIGNATURE OF APPLICANT ADDRESS DATE PHONE

RESPONSIBLE PERSON IN CHARGE OF WORK, TITLE DATE PHONE

**City of Portland, Maine - Building or Use Permit**

389 Congress Street, 04101 Tel: (207) 874-8703, Fax: (207) 874-8716

<b>Permit No:</b> 08-0748	<b>Date Applied For:</b> 06/24/2008	<b>CBL:</b> 179 B040001
------------------------------	--	----------------------------

<b>Location of Construction:</b> 92 HAMBLET AVE	<b>Owner Name:</b> WEIGEL ANNE D & JOHN J KW	<b>Owner Address:</b> 92 HAMBLET AVE	<b>Phone:</b>
<b>Business Name:</b>	<b>Contractor Name:</b> Ken Stover	<b>Contractor Address:</b> 4 Harrison Road Bridgton	<b>Phone:</b>
<b>Lessee/Buyer's Name</b>	<b>Phone:</b>	<b>Permit Type:</b> Demolitions - Building	

<b>Proposed Use:</b> Single Family Home - Demolish Single car garage	<b>Proposed Project Description:</b> Demolish Single car garage
---	--

**Dept:** Zoning      **Status:** Approved with Conditions      **Reviewer:** Ann Machado      **Approval Date:** 07/01/2008  
**Note:** **Ok to Issue:**   
1) Your present structure is legally nonconforming as to setbacks. If you are to demolish this structure on your own volition, you will only have one (1) year to replace it in the same footprint (no expansions), with the same height, and same use. Any changes to any of the above shall require that this structure meet the current zoning standards. The one (1) year starts at the time of removal. It shall be the owner's responsibility to contact the Code Enforcement Officer and notify them of that specific date.

**Dept:** Building      **Status:** Approved with Conditions      **Reviewer:** Chris Hanson      **Approval Date:** 07/07/2008  
**Note:** **Ok to Issue:**   
1) Demolition permits are valid for a period of 30 days from the date of issuance. A written request must be submitted and granted for an extension to this time period.  
2) Demo permit only! Construction requires seperate permits.  
3) Demolition permit only. No other construction activities allowed.

**Comments:**  
7/1/2008-amachado: Gave permit to Lannie to schedule pre-demolition inspection.



# Demolition of a Structure Permit Application

If you or the property owner owes real estate or personal property taxes or user charges on any property within the City, payment arrangements must be made before permits of any kind are accepted.

Location/Address of Construction: <u>EAST SIDE / 92 HAMBLET AVE</u> <u>PORTLAND, ME 04103-1714</u>		
Total Square Footage of Proposed Structure <u>240 FT<sup>2</sup></u>		Square Footage of Lot <u>7387 FT<sup>2</sup></u>
Tax Assessor's Chart, Block & Lot Chart#      Block#      Lot# <u>179      B      4041</u>	Owner: <u>JOHN KWOKA</u> <u>ANNE WEIGEL</u>	Telephone: <u>207</u> <u>828</u> <u>3789</u>
Lessee/Buyer's Name (If Applicable) <u>N/A</u>	Applicant name, address & telephone: <u>JOHN KWOKA</u> <u>ANNE WEIGEL</u> <u>92 HAMBLET AVE</u> <u>PORTLAND, ME 04103-1714</u>	Cost Of Work: \$ <u>2000.00</u> Fee: \$ <u>2000.00</u>
Current legal use: (i.e. garage, warehouse) <u>GARAGE</u> If vacant, what was the previous use? <u>—</u> How long has it been vacant?: <u>—</u>		
Project description: <u>REMOVE EXISTING SINGLE CAR DETACHED</u> <u>GARAGE IN ORDER TO CONSTRUCT NEW</u> <u>&amp; LARGER SCDG IN SAME LOCATION</u>		
Contractor's name, address & telephone: <u>KEN STOVER</u> <u>4 HARRISON RD BRIDGTON, ME 04609</u> Who should we contact when the permit is ready: <u>ANNE WEIGEL</u> Mailing address: <u>92 HAMBLET AVE</u> <u>PORTLAND, ME 04103-1714</u> Phone: <u>207.712.1877</u>		

Please submit all of the information outlined in the Demolition call list. Failure to do so will result in the automatic denial of your permit.

In order to be sure the City fully understands the full scope of the project, the Planning and Development Department may request additional information prior to the issuance of a permit. For further information or to download copies of this form and other applications visit the Inspections Division on-line at [www.portlandmaine.gov](http://www.portlandmaine.gov), or stop by the Inspections Division office, room 315 City Hall or call 874-8703.

I hereby certify that I am the Owner of record of the named property, or that the owner of record authorizes the proposed work and that I have been authorized by the owner to make this application as his/her authorized agent. I agree to conform to all applicable laws of this jurisdiction. In addition, if a permit for work described in this application is issued, I certify that the Code Official's authorized representative shall have the authority to enter all areas covered by this permit at any reasonable hour to enforce the provisions of the codes applicable to this permit.

Signature of applicant: [Signature] Date: 22 Jun 08  
[Signature] Date: 22 Jun 08

This is not a permit; you may not commence ANY work until the permit is issued.



# Demolition Call List & Requirements

Site Address: 92 HAMBLET AVE -1714 PORTLAND ME 04103 Owner: JOHN KWOKA  
ANNE WEIGEL  
 Structure Type: DETACHED GARAGE Contractor: KEN STOVER

Utility Approvals	Number	Contact Name/Date
Central Maine Power	1-800-750-4000	<u>Kent 6/23/2008</u>
Northern Utilities	797-8002 ext 6241	<u>Mark Allen 6/23/2008</u>
Portland Water District	761-8310	<u>Donna 6/23/2008</u>
Dig Safe	1-888-344-7233	<u>Kim 6/23/2008</u>

*Contractor to call again when work will be commenced w/in 30 days*

After calling Dig Safe, you must wait 72 business hours before digging can begin.

DPW/ Traffic Division (L. Cote)	874-8891	<u>Left message on 6/23/2008 @ 3:10 pm for Wey</u>
DPW/ Sealed Drain Permit (C. Merritt)	874-8822	<u>Carol 6/23/2008</u>
Historic Preservation	874-8726	<u>Left message for Debra on 6/23/2008 @ 3:15 pm</u>
Fire Dispatcher	874-8576	<u>Suzanne Morrisseau 6/23/2008</u>
DEP – Environmental (Augusta)	287-2651	<u>Sandy Moody 6/23/2008</u> <u>Left message @ 3:20 pm</u>

## Additional Requirements

- 1) Written Notice to Adjoining Owners
- 2) A Photo of the Structure(s) to be demolished
- 3) Certification from an asbestos abatement company – Not applicable – garage

All construction and demolition debris generated in Portland must be delivered to Riverside Recycling Facility at 910 Riverside Street. Source separated salvage materials placed in specifically designated containers are exempt from this provision. For more information contact Troy Moon @ 874-8467.

U.S. EPA Region 1 – No Phone call required. Just mail copy of State notification to:

Demo / Reno Clerk  
 US EPA Region I (SEA)  
 JFK Federal Building  
 Boston, MA 02203

Not applicable garage

I have contacted all of the necessary companies/departments as indicated above and attached all required documentation.

Signed: John Kwoka Date: 6/23/2008  
Anne Weigel 6/23/2008

For more information or to download this form and other permit applications visit the Inspections Division on our website at [www.portlandmaine.gov](http://www.portlandmaine.gov)

Anne Weigel & John Kwoka  
92 Hamblet Avenue  
Portland, ME 04103

June 23, 2008

Rick Brown  
Collette Desjardin  
98 Hamblet Avenue  
Portland, ME 04103

RE: Demolition of Garage, 92 Hamblet Avenue

Dear Rick & Collette,

This is the written notification required by the City that we are planning to demolish our existing garage and rebuilt a new one in its place. The work should commence by the end of July. Please let us know if you have any questions.

Sincerely,

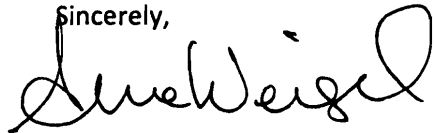

Anne Weigel

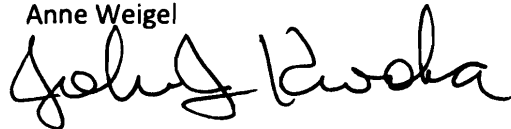

John Kwoka

Anne Weigel & John Kwoka  
92 Hamblet Avenue  
Portland, ME 04103

June 23, 2008

Ray and Deb Swenton  
88 Hamblet Avenue  
Portland, ME 04103

RE: Demolition of Garage, 92 Hamblet Avenue

Dear Ray and Deb,

This is the written notification required by the City that we are planning to demolish our existing garage and rebuilt a new one in its place. The work should commence by the end of July. Please let us know if you have any questions.

Sincerely,



Anne Weigel

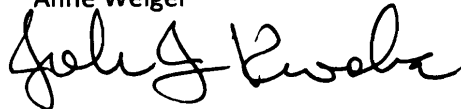

John Kwoka

Anne Weigel & John Kwoka  
92 Hamblet Avenue  
Portland, ME 04103

June 23, 2008

City of Portland  
Attn: Evergreen Cemetary  
389 Congress Street  
Portland, ME 04101

RE: Demolition of Garage, 92 Hamblet Avenue

To Whom it May Concern,

This is the written notification to abutters required by the City that we are planning to demolish our existing garage and rebuild a new one in its place. The work should commence by the end of July. Please let us know if you have any questions.

Sincerely,



Anne Weigel

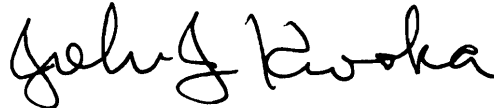

John Kwoka



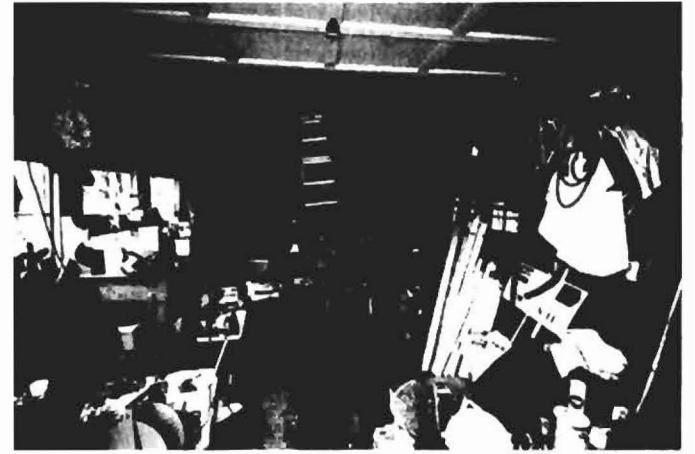
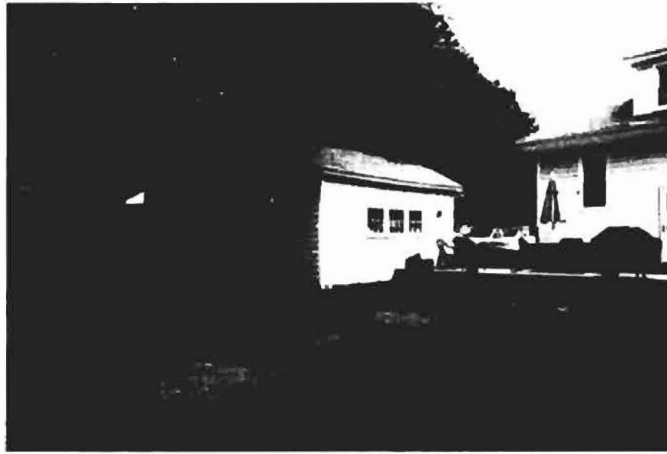

**John Kwok & Anne Weigel**  
82 Hamblet Avenue  
Portland, ME 04103

92 HAMBLET  
 PLAN BOOK 1  
 ASSESSOR'S MAP

- (A) NEW 8' PLACED REQUIRE
- (B) NEW 16' TO COM FOLLOW DETACHE PLACED REQUIRE

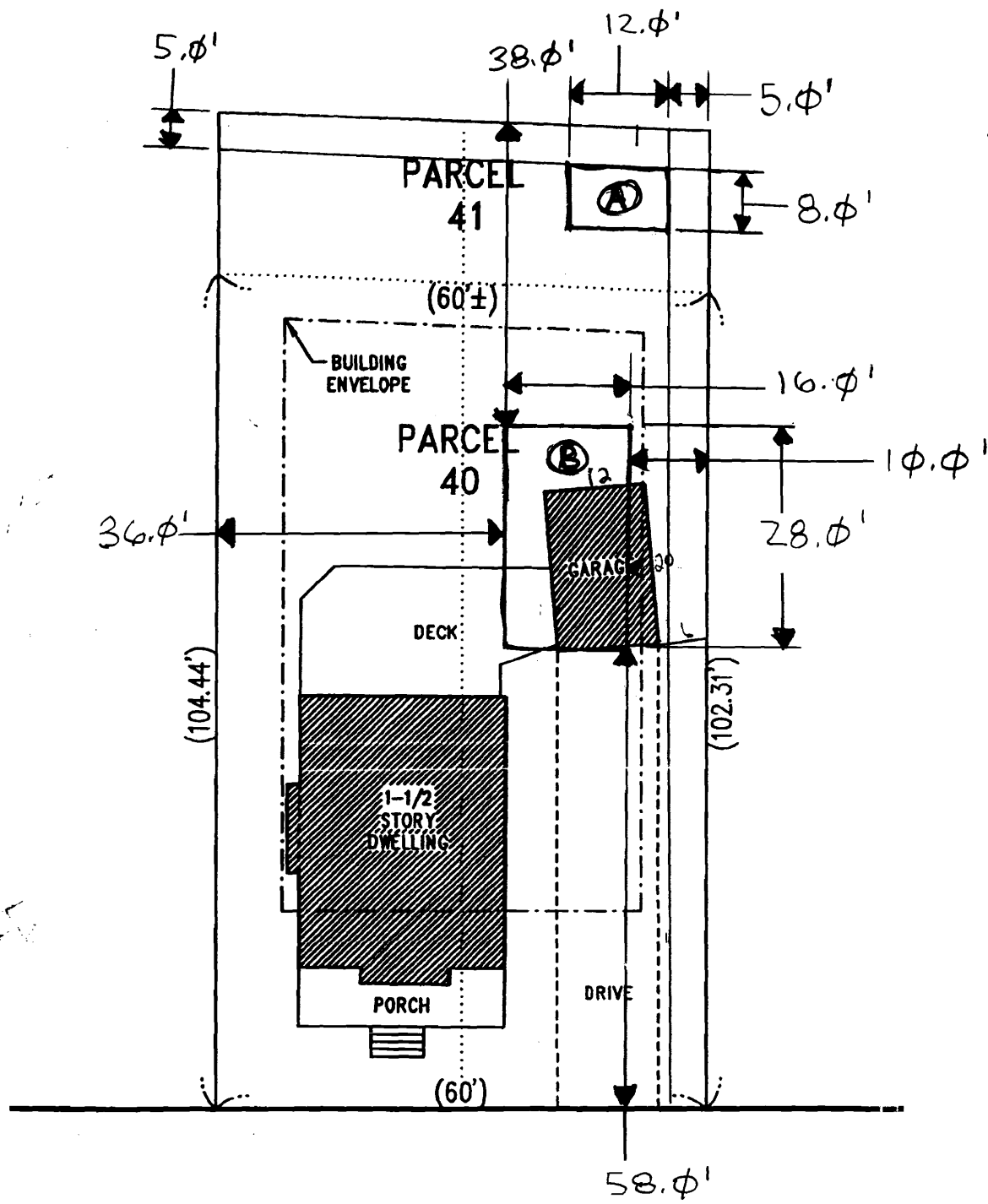
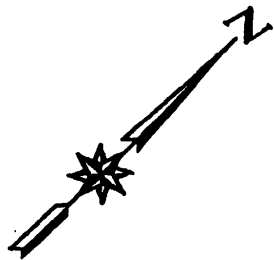

HAMBLET AVENUE

John Kwoka & Anne Weigel  
 82 Hamblet Avenue  
 Portland, ME 04109