

City of Portland, Maine - Building or Use Permit Application

389 Congress Street, 04101 Tel: (207) 874-8703, Fax: (207) 874-8716

Permit No: 08-1237	Issue Date:	CBL: 176 D015001
-----------------------	-------------	---------------------

Location of Construction: 17 MARLOW ST	Owner Name: RUDELITCH CHARLES J & MAR	Owner Address: 17 MARLOW ST	Phone: 207 210-6002
Business Name:	Contractor Name: A-1 Chimney & Masonry	Contractor Address: 31 Park Road Saco	Phone: 2072106002
Lessee/Buyer's Name	Phone:	Permit Type: HVAC	Zone: R5

Past Use: Single Family Home	Proposed Use: Single Family Home - Vermont Castings Fireplace Insert, Wood Burning, Masonary Lined	Permit Fee: \$70.00	Cost of Work: \$4,219.00	CEO District: 3
Proposed Project Description: Vermont Castings Fireplace Insert, Wood Burning, Masonary Lined		FIRE DEPT: <input type="checkbox"/> Approved <input type="checkbox"/> Denied	INSPECTION: Use Group: R3 Type: SB IRC 2003 ST. ME Solid Fuel Bd Signature: Jm 10/1/08	
		PEDESTRIAN ACTIVITIES DISTRICT (P.A.D.) Action: <input type="checkbox"/> Approved <input type="checkbox"/> Approved w/Conditions <input type="checkbox"/> Denied Signature: _____ Date: _____		

Permit Taken By: lmd	Date Applied For: 10/01/2008	Zoning Approval
-------------------------	---------------------------------	------------------------

- This permit application does not preclude the Applicant(s) from meeting applicable State and Federal Rules.
- Building permits do not include plumbing, septic or electrical work.
- Building permits are void if work is not started within six (6) months of the date of issuance. False information may invalidate a building permit and stop all work..

Special Zone or Reviews	Zoning Appeal	Historic Preservation
<input type="checkbox"/> Shoreland	<input type="checkbox"/> Variance	<input checked="" type="checkbox"/> Not in District or Landmark
<input type="checkbox"/> Wetland	<input type="checkbox"/> Miscellaneous	<input checked="" type="checkbox"/> Does Not Require Review
<input type="checkbox"/> Flood Zone <i>NA</i>	<input type="checkbox"/> Conditional Use	<input type="checkbox"/> Requires Review
<input type="checkbox"/> Subdivision	<input type="checkbox"/> Interpretation	<input type="checkbox"/> Approved <i>NA</i>
<input type="checkbox"/> Site Plan	<input type="checkbox"/> Approved	<input type="checkbox"/> Approved w/Conditions
Maj <input type="checkbox"/> Minor <input type="checkbox"/> MM <input type="checkbox"/>	<input type="checkbox"/> Denied	<input type="checkbox"/> Denied
Date: 10/1/08	Date: _____	Date: 10/1/08

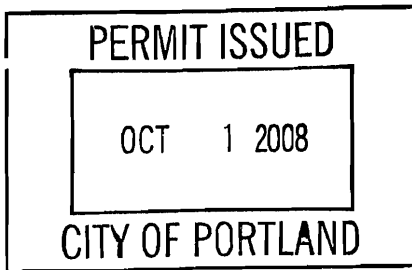

CERTIFICATION

I hereby certify that I am the owner of record of the named property, or that the proposed work is authorized by the owner of record and that I have been authorized by the owner to make this application as his authorized agent and I agree to conform to all applicable laws of this jurisdiction. In addition, if a permit for work described in the application is issued, I certify that the code official's authorized representative shall have the authority to enter all areas covered by such permit at any reasonable hour to enforce the provision of the code(s) applicable to such permit.

SIGNATURE OF APPLICANT	ADDRESS	DATE	PHONE
RESPONSIBLE PERSON IN CHARGE OF WORK, TITLE		DATE	PHONE



FILL IN AND SIGN WITH INK

08-1237

APPLICATION FOR PERMIT HEATING OR POWER EQUIPMENT

176-D.015

To the INSPECTOR OF BUILDINGS, PORTLAND, ME.

The undersigned hereby applies for a permit to install the following heating, cooking or power equipment in accordance with the Laws of Maine, the Building Code of the City of Portland, and the following specifications:

Location / CBL 17 Marlow St Use of Building single family res. Date 10-1-08
 Name and address of owner of appliance Charles Rudelitch; 17 Marlow St, Portland, ME 04103
 Installer's name and address A-1 Chimney & Masonry; 31 Park Rd, Saco, ME 04072 Telephone 207-210-6002
286-8699

Location of appliance:
 Basement Floor
 Attic Roof

Type of Fuel:
 Gas Oil Solid wood

Appliance Name: Fireplace Insert - Vermont Castings
 U.L. Approved Yes No Montpelier

Will appliance be installed in accordance with the manufacture's installation instructions? Yes No

IF NO Explain: _____

The Type of License of Installer:
 Master Plumber # _____
 Solid Fuel # _____
 Oil # _____
 Gas # _____
 Other _____

Type of Chimney:
 Masonry Lined SS liner to be installed
 Factory built _____

Metal
 Factory Built U.L. Listing # _____

Direct Vent
 Type _____ UL# _____

Type of Fuel Tank
 Oil n/a OCT 1 2003
 Gas

Size of Tank n/a

Number of Tanks n/a

Distance from Tank to Center of Flame n/a feet.

Cost of Work: \$ 4,219
 Permit Fee: \$ 70.00

Approved

Approved with Conditions

Fire: _____
 Ele.: _____
 Bldg.: _____

See attached letter or requirement

 Inspector's Signature Date Approved

Signature of Installer _____

White - Inspection Yellow - File Pink - Applicant's Gold - Assessor's Copy

City of Portland, Maine - Building or Use Permit

389 Congress Street, 04101 Tel: (207) 874-8703, Fax: (207) 874-8716

Permit No: 08-1237	Date Applied For: 10/01/2008	CBL: 176 D015001
------------------------------	--	----------------------------

Location of Construction: 17 MARLOW ST	Owner Name: RUDELITCH CHARLES J & MAR	Owner Address: 17 MARLOW ST	Phone: 207 210-6002
Business Name:	Contractor Name: A-1 Chimney & Masonery	Contractor Address: 31 Park Road Saco	Phone (207) 210-6002
Lessee/Buyer's Name	Phone:	Permit Type: HVAC	

Proposed Use: Single Family Home - Vermont Castings Fireplace Insert, Wood Burning, Masonary Lined	Proposed Project Description: Vermont Castings Fireplace Insert, Wood Burning, Masonary Lined
--	---

Dept: Zoning	Status: Not Applicable	Reviewer:	Approval Date:	Ok to Issue: <input checked="" type="checkbox"/>
Note:				
Dept: Building	Status: Approved with Conditions	Reviewer: Tom Markley	Approval Date: 10/01/2008	Ok to Issue: <input checked="" type="checkbox"/>
Note:	1) The heating appliance/stove shall be installed, maintained and operated in accordance with the terms of the listing. 2) Application approval based upon information provided by applicant. Any deviation from approved plans requires separate review and approval prior to work. 3) Installation shall comply with 2003 International Mechanical Code and State of Maine Oil and Solid Fuel Board Laws and Rules			

Specifications

Montpelier Medium Insert

EPA Emissions Rating	3.0 g/hr
Range of heat output*	10,100 - 27,550 BTU/hr
Maximum heat output**	50,000 BTU/hr
Area heated***	1,500 sq. ft.
Size of wood splits	18"-22" (460 - 560 mm)
Fuel Capacity	30lbs. (13.5kg)
Loading	Front
Flue size	6" (150mm)
Fireplace Insert weight	335 lbs. (152 kg)
Primary Air Control	Manual
Glass panel	High-temperature ceramic
Flue exit position	Top
Blower rating	150 cfm. (115V, 60Hz)

*Under specific test conditions used during EPA emissions standard testing.

**This value can vary depending on how the unit is operated, and the type and moisture content of the fuel used. The figure shown is based on maximum fuel consumption obtained under laboratory conditions and with average efficiencies.

***These values are based on operation in building-code conforming homes under typical winter climate conditions in New England. If your home is of nonstandard construction (e.g. unusually well insulated, not insulated, built under ground, etc.) or if you live in a more severe or more temperate climate, these figures may not apply. Since so many variables affect performance, consult your Vermont Castings' Authorized Dealer to determine realistic expectations for your home.

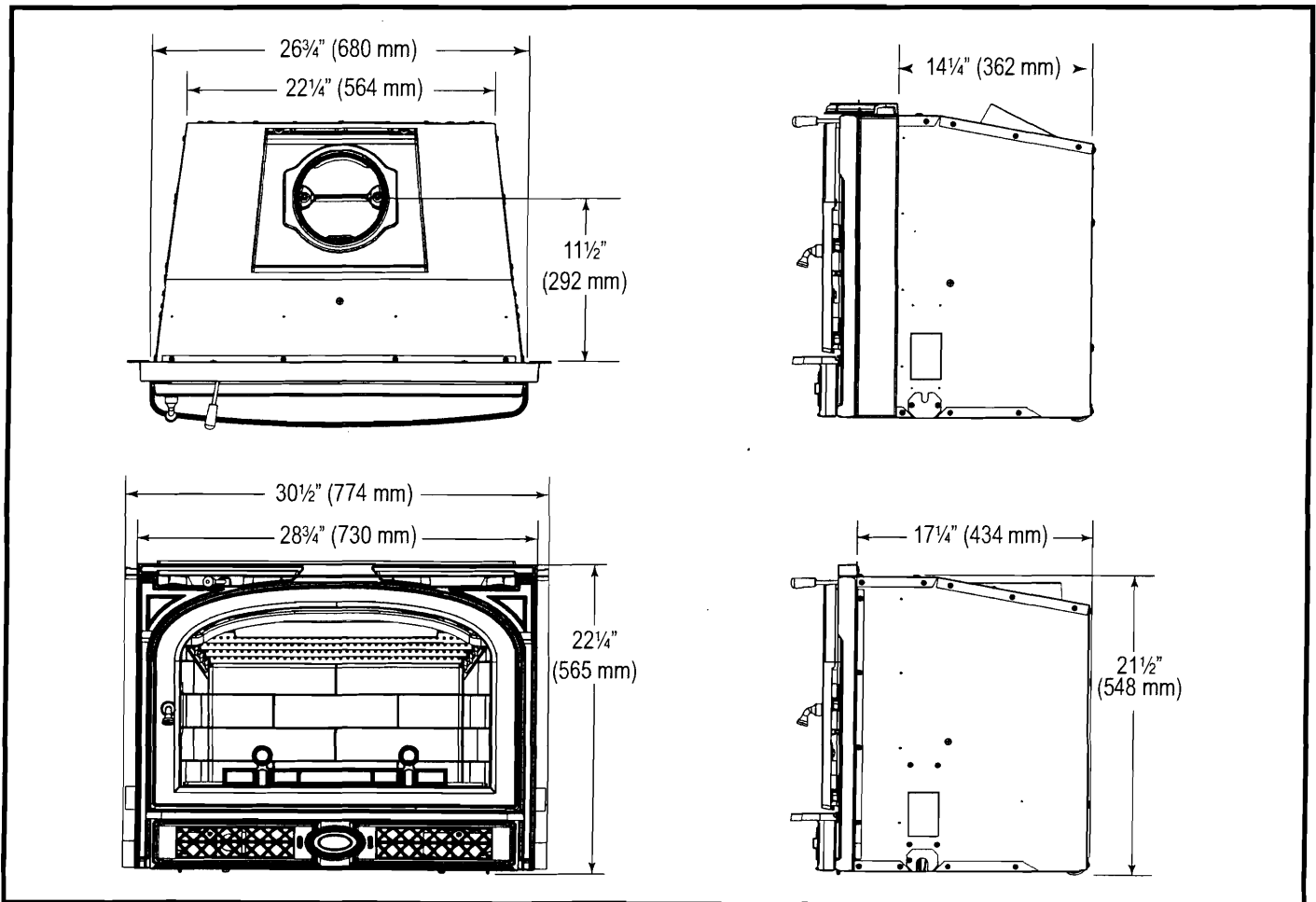

Fig. 1 Montpelier Medium Insert dimensions.