

FORCE™

steam

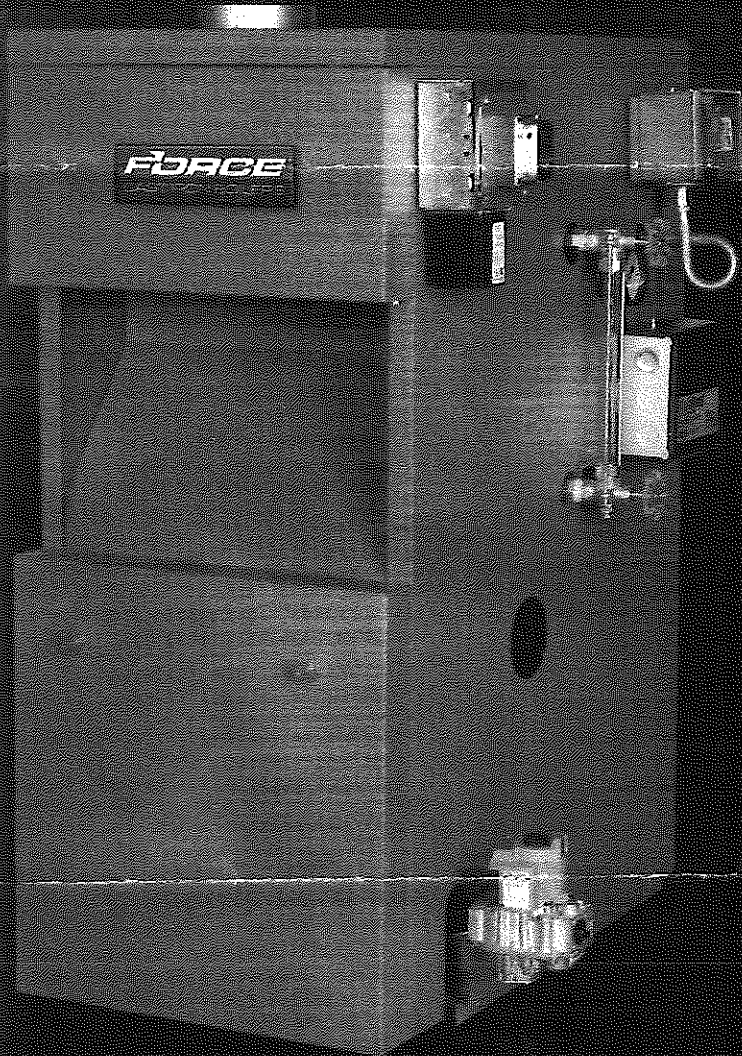

Standard Features

- Offered exclusively by Ferguson
- Natural gas
(LP conversion kit available)
- Electronic ignition
- Built-in draft diverter – fits in low spaces
- Cast iron heat exchanger, meets ASME boiler code and pressure vessel code
- Metal section connectors resist chemicals, increase the life of the boiler
- Fully assembled
- 10-year limited warranty

FERGUSON
Nobody expects more from us than we do®

FERGUSON
Heating & Cooling

Lyon, Conklin & Co. Inc.
A FERGUSON ENTERPRISE

Technical Information

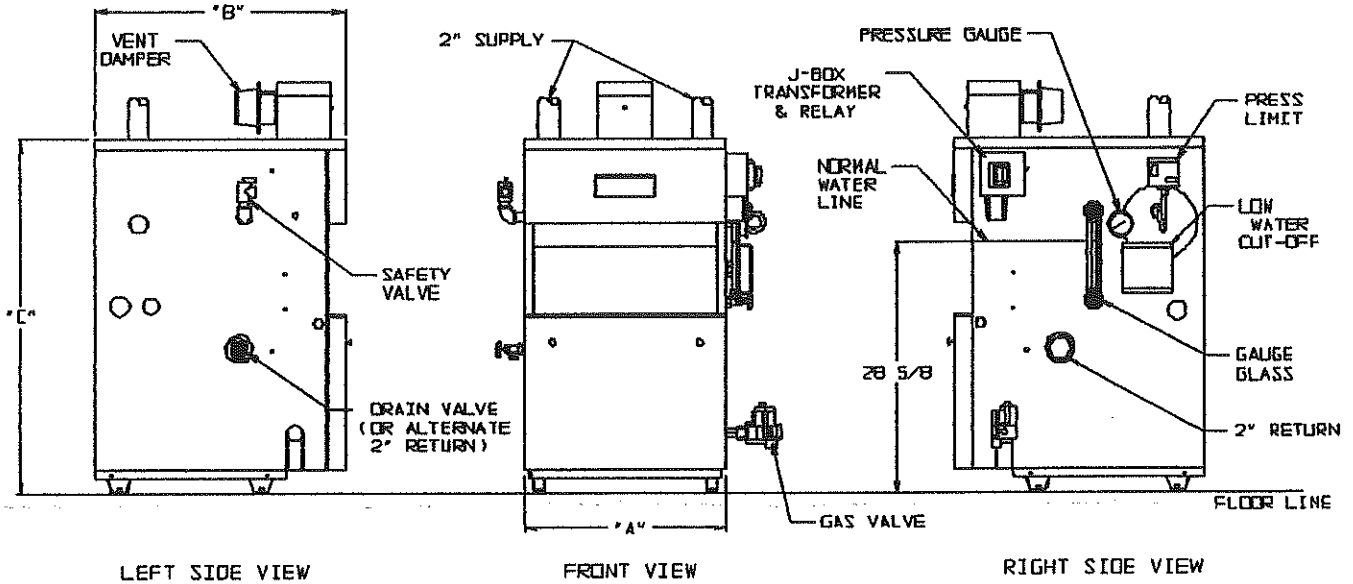

Model	Dimensions (Inches)			Flue Collar Diameter	AFUE%	Input Rate (MBH)	DOE Heating Capacity (MBH)	Net AHRI Steam (MBH)	Steam (Sq. Ft.)	Approx. Shipping Weight (lbs.)
	"A"	"B"	"C"							
FORCESTM03	12-3/4	28"	40-7/16	4	81.9	69	56	42	175	350
FORCESTM04	16	28"	40-7/16	5	82.0	103	84	63	263	420
FORCESTM05	19-1/4	28"	40-7/16	6	82.0	138	113	85	354	485
FORCESTM06	22-1/2	28"	40-7/16	6	82.1	172	142	107	446	555
FORCESTM07	25-3/4	30"	40-7/16	7	82.1	207	171	128	533	620
FORCESTM08	29	30"	40-7/16	7	82.2	241	199	149	621	690

The Net AHRI Steam Ratings shown are based on a piping and pickup allowance of 1.333. The manufacturer should be consulted before selecting a boiler for installations having unusual piping and pickup requirements, such as intermittent system operation, extensive piping systems, etc. Ratings shown are for installations at sea level and elevations up to 2,000 feet.

Additional Standard Features

- Fully packaged
- Insulated jacket
- Pressure limit
- 15 PSI safety valve
- Honeywell gas valve
- Hydrolevel probe-type LWCO
- Steam pressure gauge
- Built-in draft diverter
- Flame roll out switch
- Blocked vent switch
- Vent damper
- Drain valve

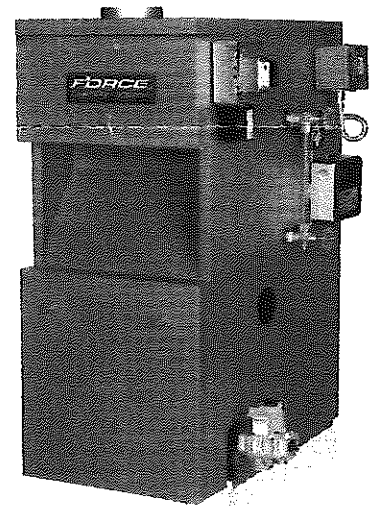

FERGUSON[®]
Nobody expects more from us than we do[®]