

BUILDING PERMIT

Permit Number: 101014

PORTLAND HOUSING AUTHORITY

Access existing front steps & deck - Front side 75, 77, 79, 81, 83, 85, 87, 89, Cummings St. Side 3

C 167 E001001

Person or persons, firm or corporation accepting this permit shall comply with all the Statutes of Maine and of the Ordinances of the City of Portland regulating maintenance and use of buildings and structures, and of the application on file in

street line
mark requires

Notification of inspection must be given and written permission procured before this building or part thereof is lath or other work is set-in. 24 HOUR NOTICE IS REQUIRED.

A certificate of occupancy must be procured by owner before this building or part thereof is occupied.

PERMIT ISSUED

SEP 24 2010

Director - Building Inspection
City of Portland

PENALTY FOR REMOVING THIS CARD

City of Portland, Maine - Building or Use Permit Application
 389 Congress Street, 04101 Tel: (207) 874-8703, Fax: (207) 874-8716

Permit No: 10-1014	Issue Date:	CBL: 167 E001001
-----------------------	-------------	---------------------

Location of Construction: 63 FRONT ST	Owner Name: PORTLAND HOUSING AUTHOR	Owner Address: 14 BAXTER BLVD	Phone:
Business Name:	Contractor Name: Mark Label	Contractor Address: 6 Eastern Avenue Falmouth	Phone: 2076504020
Lessee/Buyer's Name	Phone:	Permit Type: Alterations - Multi Family	Zone: R-5

Past Use: Multi-unit housing	Proposed Use: Replace existing front steps & rear decks units - Front St side 75, 77, 79; 81, 83, 85, 87, 89, Cummings St. Side 36, 38, 40, 42, 44, West Presumpscot St side 43, 45, <i>changed rear deck</i>	Permit Fee: \$260.00	Cost of Work: \$24,000.00	CEO District: 4
---------------------------------	---	-------------------------	------------------------------	--------------------

Proposed Project Description:
 Replace existing front ~~steps & rear~~ decks units - Front St side 75, 77, 79, 81, 83, 85, 87, 89, Cummings St. Side 36, 38, 40, 42, 44, West Presumpscot St side 43, 45, *rear decks*

FIRE DEPT: <i>w/conditions</i> 9/1/10	<input checked="" type="checkbox"/> Approved <input type="checkbox"/> Denied	INSPECTION: Use Group: <i>R-2/3</i> Type: <i>STB</i> <i>TBC 2009</i>
Signature: <i>[Signature]</i>	Signature: <i>[Signature]</i>	
PEDESTRIAN ACTIVITIES DISTRICT (P.A.D.)		
Action: <input type="checkbox"/> Approved <input type="checkbox"/> Approved w/Conditions <input type="checkbox"/> Denied		
Signature:	Date:	

Permit Taken By: Idobson	Date Applied For: 08/17/2010
-----------------------------	---------------------------------

Zoning Approval

- This permit application does not preclude the Applicant(s) from meeting applicable State and Federal Rules.
- Building permits do not include plumbing, septic or electrical work.
- Building permits are void if work is not started within six (6) months of the date of issuance. False information may invalidate a building permit and stop all work..

Special Zone or Reviews <input type="checkbox"/> Shoreland <input type="checkbox"/> Wetland <input type="checkbox"/> Flood Zone <input type="checkbox"/> Subdivision <input type="checkbox"/> Site Plan Maj <input type="checkbox"/> Minor <input type="checkbox"/> MM <input type="checkbox"/> Date: <i>8/26/10</i> <i>[Signature]</i>	Zoning Appeal <input type="checkbox"/> Variance <input type="checkbox"/> Miscellaneous <input type="checkbox"/> Conditional Use <input type="checkbox"/> Interpretation <input type="checkbox"/> Approved <input type="checkbox"/> Denied Date:	Historic Preservation <input checked="" type="checkbox"/> Not in District or Landmark <input type="checkbox"/> Does Not Require Review <input type="checkbox"/> Requires Review <input type="checkbox"/> Approved <input type="checkbox"/> Approved w/Conditions <input type="checkbox"/> Denied Date: <i>[Signature]</i>
---	---	---

PERMIT ISSUED

SEP 3 4 2010

City of Portland

CERTIFICATION

I hereby certify that I am the owner of record of the named property, or that the proposed work is authorized by the owner of record and that I have been authorized by the owner to make this application as his authorized agent and I agree to conform to all applicable laws of this jurisdiction. In addition, if a permit for work described in the application is issued, I certify that the code official's authorized representative shall have the authority to enter all areas covered by such permit at any reasonable hour to enforce the provision of the code(s) applicable to such permit.

SIGNATURE OF APPLICANT	ADDRESS	DATE	PHONE
------------------------	---------	------	-------

RESPONSIBLE PERSON IN CHARGE OF WORK, TITLE	DATE	PHONE
---	------	-------



CITY OF PORTLAND, MAINE

Department of Building Inspections

Original Receipt

8.17. 2010

Received from

Mark Label

Location of Work

63 Front St

Cost of Construction \$ _____

Building Fee: _____

Permit Fee \$ _____

Site Fee: _____

Certificate of Occupancy Fee: _____

Total: 260

Building (1L) _____

Plumbing (15) _____

Electrical (12) _____

Site Plan (U2) _____

Other _____

CBL: 167-S-1

Check #: 521

Total Collected \$ 260

**No work is to be started until permit issued.
Please keep original receipt for your records.**

Taken by: _____

WHITE - Applicant's Copy

YELLOW - Office Copy

PINK - Permit Copy

City of Portland, Maine - Building or Use Permit

389 Congress Street, 04101 Tel: (207) 874-8703, Fax: (207) 874-8716

Permit No: 10-1014	Date Applied For: 08/17/2010	CBL: 167 E001001
-----------------------	---------------------------------	---------------------

Location of Construction: 63 FRONT ST	Owner Name: PORTLAND HOUSING AUTHOR	Owner Address: 14 BAXTER BLVD	Phone:
Business Name:	Contractor Name: Mark Lebel	Contractor Address: 6 Eastern Avenue Falmouth	Phone: (207) 650-4020
Lessee/Buyer's Name	Phone:	Permit Type: Alterations - Multi Family	

Proposed Use: Replace existing front decks on units - Front St side 75, 77, 79, 81, 83, 85, 87, 89, Cummings St. Side 107(36), 105(38), 103(40), 101(42), 99(44), & replace rear decks on units on West Presumpscot St side 43, 45,	Proposed Project Description: Replace existing front decks on units - Front St side 75, 77, 79, 81, 83, 85, 87, 89, Cummings St. Side 107(36), 105(38), 103(40), (101(42), 99(44) & rear decks on units on West Presumpscot St side 43, 45,
---	---

Dept: Zoning	Status: Approved with Conditions	Reviewer: Ann Machado	Approval Date: 08/26/2010
Note:			Ok to Issue: ✓
1) This permit is being issued with the condition that all the work wil take place within the existng footprints.			
2) This permit is being approved on the basis of plans submitted. Any deviations shall require a separate approval before starting that work.			
Dept: Building	Status: Approved with Conditions	Reviewer: Tammy Munson	Approval Date: 09/24/2010
Note:			Ok to Issue: ✓
1) Separate permits are required for any electrical, plumbing, sprinkler, fire alarm HVAC systems, heating appliancees, including pellet/wood stoves, commereial hood exhaust systems and fuel tanks. Separate plans may need to be submitted for approval as a part of this process.			
2) Application approval based upon information provided by applicant. Any deviation from approved plans requires separate review and approval prior to work.			
Dept: Fire	Status: Approved with Conditions	Reviewer: Ben Wallace Jr.	Approval Date: 09/01/2010
Note:			Ok to Issue: ✓
1) New exterior stairs must have a hand rail at each side (101-7.2.2.4.1.1). Hand rails must extend horizontally beyond the top tead 12" and beyond the bottom tread along the same slope for the distance of one tread (101-7.2.2.4.4.10).			
2) All eonstruction shall comply with City Code Chapter 10.			

Comments:
8/26/2010-amachado: Left vcm for Mark Lebel. Is he just doing the rear decks on tis permit or the front porches too?

PERMIT ISSUED

SEP 04 2010

City of Portland

BUILDING PERMIT INSPECTION PROCEDURES

Please call 874-8703 or 874-8693 (ONLY)

or email: buildinginspections@portlandmaine.gov

With the issuance of this permit, the owner, builder or their designee is required to provide adequate notice to the City of Portland Inspection Services for the following inspections. Appointments must be requested 48 to 72 hours in advance of the required inspection. The inspection date will need to be confirmed by this office.

- Please read the conditions of approval that is attached to this permit!! Contact this office if you have any questions.
- Permits expire in 6 months, if the project is not started or ceases for 6 months.
- If the inspection requirements are not followed as stated below additional fees may be incurred due to the issuance of a "Stop Work Order" and subsequent release to continue with construction.

 X Footing/Building Location Inspection: Prior to pouring concrete or setting precast piers

 X Framing/Rough Plumbing/Electrical: Prior to Any Insulating or drywalling

 X Final inspection required at completion of work.

The project cannot move to the next phase prior to the required inspection and approval to continue, REGARDLESS OF THE NOTICE OR CIRCUMSTANCES.

IF THE PERMIT REQUIRES A CERTIFICATE OF OCCUPANCY, IT MUST BE PAID FOR AND ISSUED TO THE OWNER OR DESIGNEE BEFORE THE SPACE MAY BE OCCUPIED.

PERMIT ISSUED

SEP 8² 4 2010

City of Portland



General Building Permit Application

If you or the property owner owes real estate or personal property taxes or user charges on any property within the City, payment arrangements must be made before permits of any kind are accepted.

Location/Address of Construction: <u>63 Front St</u>		
Total Square Footage of Proposed Structure/Area	Square Footage of Lot	Number of Stories
Tax Assessor's Chart, Block & Lot Chart# <u>167</u> Block# <u>E</u> Lot# <u>1</u>	Applicant * <u>must</u> be owner, Lessee or Buyer* Name <u>PORTLAND NEWS INC</u> Address <u>14 BAXTER BLVD.</u> City, State & Zip	Telephone:
Lessee/DBA (If Applicable)	Owner (if different from Applicant) Name Address City, State & Zip	Cost Of Work: \$ <u>24,000</u> C of O Fee: \$ _____ Total Fee: \$ <u>260</u>
Current legal use (i.e. single family) _____ Number of Residential Units _____ If vacant, what was the previous use? _____ Proposed Specific use: _____ Is property part of a subdivision? _____ If yes, please name _____ Project description: <u>Deck Replacement - #75, 77, 79, 81, 83, 85, 87, 89 Front St</u> <u>#36, 38, 40, 42, 44 Cummings St</u> <u>#43, 45 West Presumpscott</u> <u>(Rear)</u>		
Contractor's name: <u>Mark R Lebel</u>		
Address: <u>6 Eastern Ave</u>		
City, State & Zip: <u>Falmouth Me.</u>		Telephone: <u>04105</u>
Who should we contact when the permit is ready: <u>Mark R Lebel</u>		Telephone: <u>650-4020</u>
Mailing address: _____		

Please submit all of the information outlined on the applicable Checklist. Failure to do so will result in the automatic denial of your permit.

In order to be sure the City fully understands the full scope of the project, the Planning and Development Department may request additional information prior to the issuance of a permit. For further information or to download copies of this form and other applications visit the Inspections Division on-line at www.portlandmaine.gov, or stop by the Inspections Division office, room 315 City Hall or call 874-8703.

I hereby certify that I am the Owner of record of the named property, or that the owner of record authorizes the proposed work and that I have been authorized by the owner to make this application as his/her authorized agent. I agree to conform to all applicable laws of this jurisdiction. In addition, if a permit for work described in this application is issued, I certify that the Code Official's authorized representative shall have the authority to enter all areas covered by this permit at any reasonable hour to enforce the provisions of the codes applicable to this permit.

Signature: Mark R Lebel Date: 8/17/10

This is not a permit; you may not commence ANY work until the permit is issued

Map

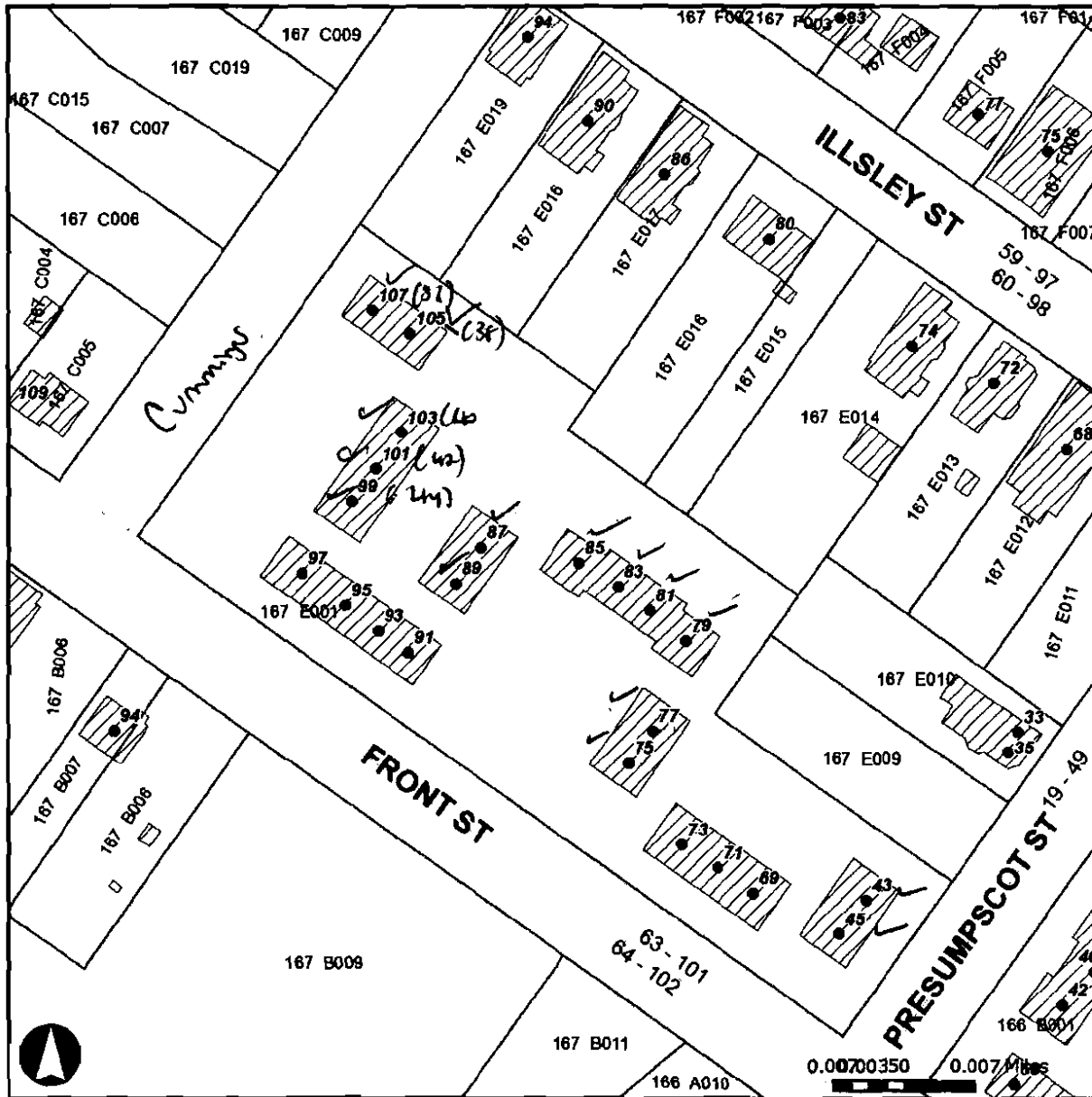

Interstate □	Traveled Ways —	Jetport □	Ocean □
Streets □	Stream —	County Streets —	
Buildings □ Building □ Out Building	Wetland □ swamp	—A15 —A21 —A31	
Parcels □	Lake/Pond □ □ under_road □ waterbody	ME Towns □ Land □ Water Body	

CUMMINGS STREET
(PAPER STREET)

INSTALL NEW
BITUMINOUS
WALKWAY

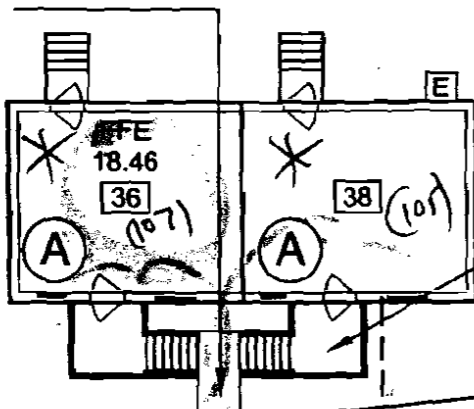

INSTALL DECK AND
STAIRS - TYPE 'A' -
ON FRONT OF
UNITS 36 AND 38.

LAWN
AREA

PLAYGROUND

LAWN
AREA

EXISTING
BITUMINOUS
SIDEWALK

LAWN
AREA

INSTALL DECK AND
STAIRS - TYPE 'A' -
ON FRONT OF UNITS
40, 42 AND 44.

INSTALL NEW
BITUMINOUS
WALKWAYS

EXISTING
BITUMINOUS
PARKING LOT

MAINTAIN ACCESS AT
EITHER FRONT OR
REAR OF BUILDING AT
ALL TIMES, TYPICAL.

20 FOOT
SETBACK

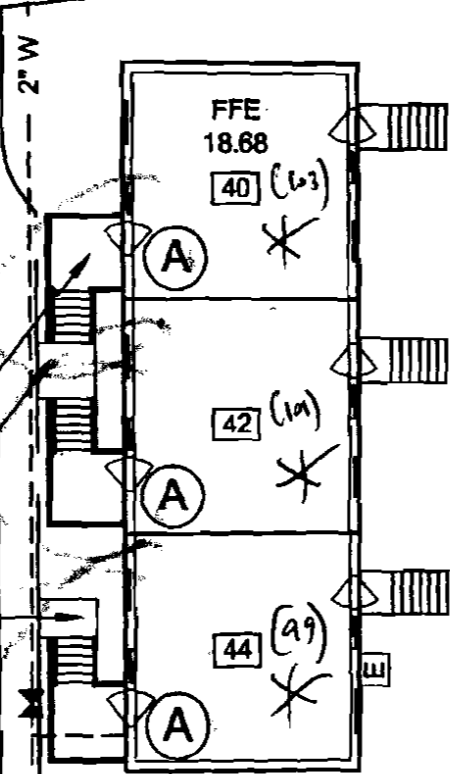

LAWN
AREA

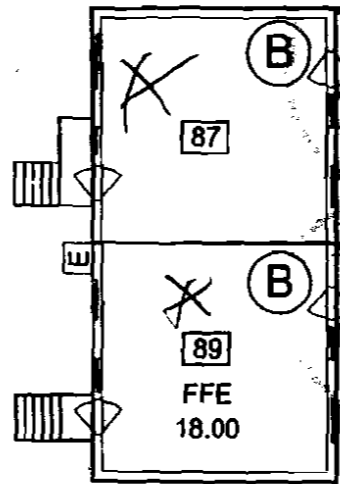

INSTALL NEW
BITUMINOUS
WALKWAY

INSTALL NEW
BITUMINOUS
WALKWAY

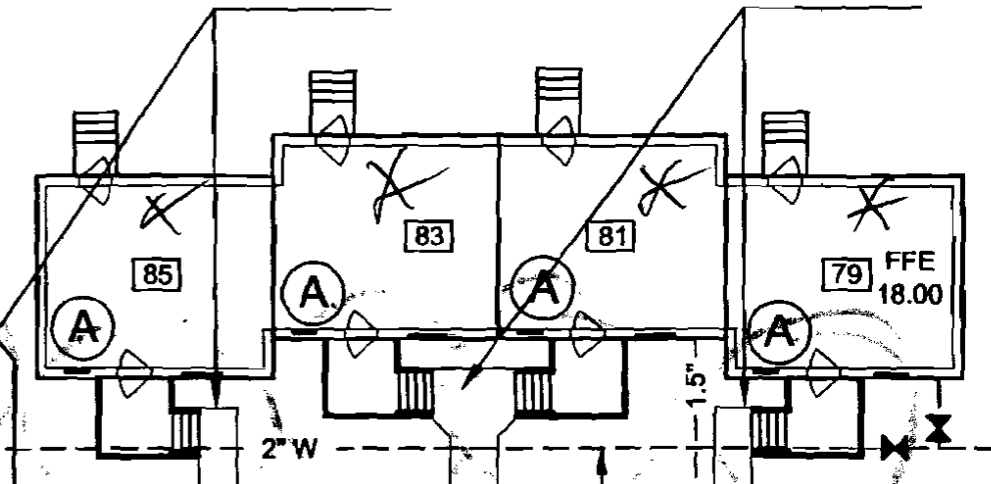

LA
AF

4" GAS
5" SS INV.: 7.89
INSTALL DECK AND STAIRS - TYPE
'B' - ON FRONT OF UNITS 87 AND 89.
INSTALL DECK AND STAIRS -
TYPE 'A' - ON FRONT OF UNITS
75, 77, 79, 81, 83 AND 85.
INSTALL NEW BITUMINOUS WALKWAY
INSTALL DECK AND STAIRS - TYPE 'C'
- ON REAR OF UNITS 91, 93, 95 AND 97.

EXISTING
BITUMINOUS
PARKING LOT

LAWN
AREA

LAWN
AREA

EXISTING BITUMINOUS
SIDEWALK

Front St.

Permit # 1 100399
ISSUED 5/18/10

Permit # 2

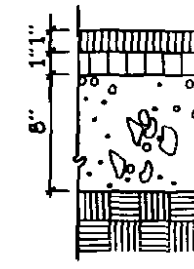
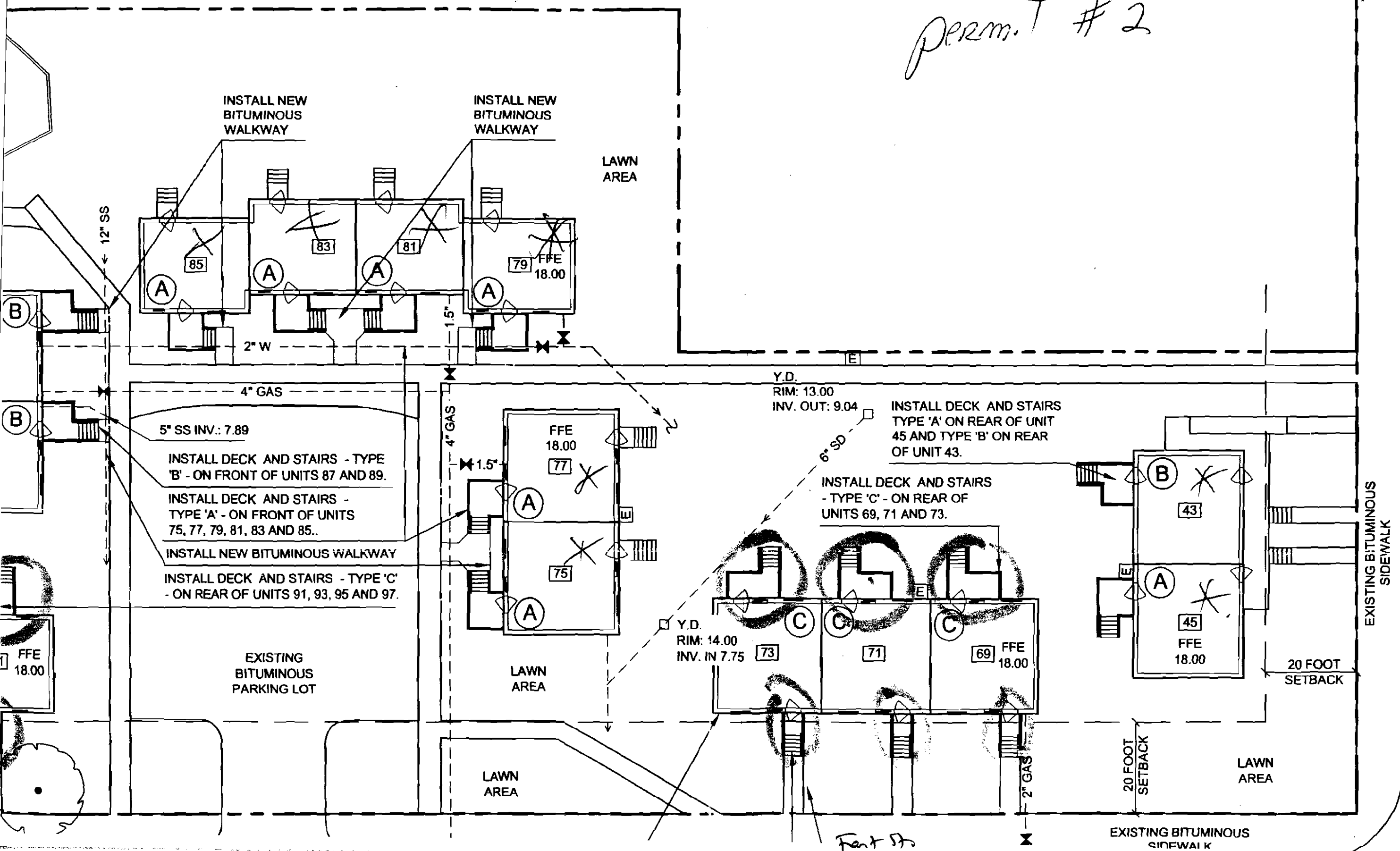

1 B
3 NO

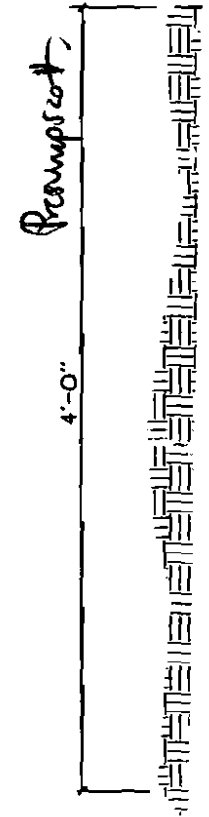

2 F
3