

**DISPLAY THIS CARD ON PRINCIPAL FRONTAGE OF WORK**

Please Read  
Application And  
Notes, If Any,  
Attached

PERMIT ISSUED BY **CITY OF PORTLAND**

BUILDING DEPARTMENT

**PERMIT**

CITY OF PORTLAND

Permit Number: 101211

This is to certify that PORTLAND HOUSING AUTHORITY

has permission to Replace existing front decks of its Fr. St# 57 - Hsley - 56 W Presumpscot

AT 37 Front St City of Portland 166 B01001

provided that the person or persons, firm or corporation accepting this permit shall comply with all of the provisions of the Statutes of Maine and of the Ordinances of the City of Portland regulating the construction, maintenance and use of buildings and structures, and of the application on file in this department.

Apply to Public Works for street line and grade if nature of work requires such information.

Notification of inspection must be given and written permission procured before this building or part thereof is lathed or otherwise used-in. 24 HOURS NOTICE IS REQUIRED.

A certificate of occupancy must be procured by owner before this building or part thereof is occupied.

**OTHER REQUIRED APPROVALS**

Fire Dept. CAPT. R. [Signature]

Health Dept. \_\_\_\_\_

Appeal Board \_\_\_\_\_

Other \_\_\_\_\_

Department Name

Director - Building & Inspection Services

**PENALTY FOR REMOVING THIS CARD**

**City of Portland, Maine - Building or Use Permit Application**

389 Congress Street, 04101 Tel: (207) 874-8703, Fax: (207) 874-8716

Permit No: 10-1311	Issue Date:	CBL: 166 B001001
-----------------------	-------------	---------------------

Location of Construction: 37 Front St	Owner Name: PORTLAND HOUSING AUTHOR	Owner Address: 14 BAXTER BLVD	Phone:
Business Name:	Contractor Name: Mark Label	Contractor Address: 6 Eastern Avenue Falmouth	Phone: 2076504020
Lessee/Buyer's Name	Phone:	Permit Type: Alterations - Multi Family	Zone: R5

Past Use: Multi-unit Housing	Proposed Use: Multi-unit Housing - Replace existing front decks on units - Front St# 57, 59 Illsley#54, 56 W Presumpscot 24,26,28,38,40,42	Permit Fee: \$220.00	Cost of Work: \$20,000.00	CEO District: 4
Proposed Project Description: Replace existing front decks on units - Front St# 57, 59 Illsley#54, 56 W Presumpscot 24,26,28,38,40,42		FIRE DEPT: <input checked="" type="checkbox"/> Approved <input type="checkbox"/> Denied <i>* See Cond.</i>	INSPECTION: Use Group: R-2/R3 Type SB Signature: JMB 11/23/10 Date: 11/23/10	

Signature: <i>RL</i>		Signature: <i>JMB 11/23/10</i>	
PEDESTRIAN ACTIVITIES DISTRICT (P.A.D.)			
Action: <input type="checkbox"/> Approved <input type="checkbox"/> Approved w/Conditions <input type="checkbox"/> Denied			
Signature:		Date:	

Permit Taken By: Idobson	Date Applied For: 10/20/2010	<b>Zoning Approval</b>	
-----------------------------	---------------------------------	------------------------	--

<p>1. This permit application does not preclude the Applicant(s) from meeting applicable State and Federal Rules.</p> <p>2. Building permits do not include plumbing, septic or electrical work.</p> <p>3. Building permits are void if work is not started within six (6) months of the date of issuance. False information may invalidate a building permit and stop all work.</p>	<p>Special Zone or Reviews</p> <input type="checkbox"/> Shrivelud <input type="checkbox"/> Wetland <input type="checkbox"/> Flood Zone <input type="checkbox"/> Subdivision <input type="checkbox"/> Site Plan	<p>Zoning Appeal</p> <input type="checkbox"/> Variance <input type="checkbox"/> Miscellaneous <input type="checkbox"/> Conditional Use <input type="checkbox"/> Interpretation <input type="checkbox"/> Approved <input type="checkbox"/> Denied	<p>Historic Preservation</p> <input checked="" type="checkbox"/> Not in District or Landmark <input type="checkbox"/> Does Not Require Review <input type="checkbox"/> Requires Review <input type="checkbox"/> Approved <input type="checkbox"/> Approved w/Conditions <input type="checkbox"/> Denied
	<p>Minor <input type="checkbox"/> MM <input type="checkbox"/></p> <p>Date: <i>10/20/10</i></p>	Date:	Date: <i>11/23/10</i>

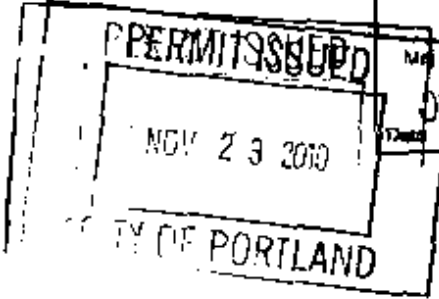

**CERTIFICATION**

I hereby certify that I am the owner of record of the named property, or that the proposed work is authorized by the owner of record and that I have been authorized by the owner to make this application as his authorized agent and I agree to conform to all applicable laws of this jurisdiction. In addition, if a permit for work described in the application is issued, I certify that the code official's authorized representative shall have the authority to enter all areas covered by such permit at any reasonable hour to enforce the provision of the code(s) applicable to such permit.

SIGNATURE OF APPLICANT	ADDRESS	DATE	PHONE
------------------------	---------	------	-------

**City of Portland, Maine - Building or Use Permit**

389 Congress Street, 04101 Tel: (207) 874-8703, Fax: (207) 874-8716

Permit No: 10-1311	Date Applied For: 10/20/2010	CBL: 166 B001001
-----------------------	---------------------------------	---------------------

Location of Construction: 37 Front St	Owner Name: PORTLAND HOUSING AUTHOR	Owner Address: 14 BAXTER BLVD	Phone:
Business Name:	Contractor Name: Mark Label	Contractor Address: 6 Eastern Avenue Falmouth	Phone: (207) 650-4020
Lessee/Buyer's Name:	Phone:	Permit Type: Alterations - Multi Family	

Proposed Use: Multi-unit Housing -Replace existing front decks on units - Front St# 57, 59 Ilisley#34, 56 W Presumpscot 24,26,28,38,40,42	Proposed Project Description: Replace existing front decks on units - Front St# 57, 59 Ilisley#54, 56 W Presumpscot 24,26,28,38,40,42
--	--

Dept: Zoning	Status: Approved with Conditions	Reviewer: Ann Machado	Approval Date: 10/20/2010
Note:	Ok to Issue: <input checked="" type="checkbox"/>		
1) This permit is being approved on the basis of plans submitted. Any deviations shall require a separate approval before starting that work.			
Dept: Building	Status: Approved with Conditions	Reviewer: Jeanine Dourke	Approval Date: 11/23/2010
Note:	Ok to Issue: <input checked="" type="checkbox"/>		
1) Application approval based upon information provided by applicant with dated revisions. Any deviation from approved plans requires separate review and approval prior to work.			
Dept: Fire	Status: Approved with Conditions	Reviewer: Capt Keith Gautreau	Approval Date: 10/26/2010
Note:	Ok to Issue: <input checked="" type="checkbox"/>		
1) All construction shall comply with City Code Chapter 10.			

<b>Comments:</b>
11/17/2010-jrb: Left vmag for Mark L. For details on number of units per building section, carrying beam, joist hangers, rise/run, and possible increase in number of handrails.
11/18/2010-jrb: Mark came into the office, verified individual units, using joist hangers and he needs to submit plan 5 showing these are the smaller decks. Also asked for an as built change detail.
11/23/2010-jrb: Mark L. Submitted the plans

## **BUILDING PERMIT INSPECTION PROCEDURES**

**Please call 874-8703 or 874-8693 (ONLY )**

**or email: [buildinginspections@portlandmaine.gov](mailto:buildinginspections@portlandmaine.gov)**

With the issuance of this permit, the owner, builder or their designee is required to provide adequate notice to the City of Portland Inspection Services for the following inspections. Appointments must be requested 48 to 72 hours in advance of the required inspection. The inspection date will need to be confirmed by this office.

- **Please read the conditions of approval that is attached to this permit!! Contact this office if you have any questions.**
- **Permits expire in 6 months, if the project is not started or ceases for 6 months.**
- **If the inspection requirements are not followed as stated below additional fees may be incurred due to the issuance of a "Stop Work Order" and subsequent release to continue with construction.**

  **X**   **Footing/Building Location Inspection: Prior to pouring concrete or setting precast piers**

  **X**   **Final Inspection required at completion of work.**

**The project cannot move to the next phase prior to the required inspection and approval to continue, REGARDLESS OF THE NOTICE OR CIRCUMSTANCES.**

**IF THE PERMIT REQUIRES A CERTIFICATE OF OCCUPANCY, IT MUST BE PAID FOR AND ISSUED TO THE OWNER OR DESIGNEE BEFORE THE SPACE MAY BE OCCUPIED.**



# CITY OF PORTLAND, MAINE

Department of Building Inspections

## Original Receipt

\_\_\_\_\_ 10.20 20 10 \_\_\_\_\_

Received from \_\_\_\_\_ Mark Lord \_\_\_\_\_

Location of Work \_\_\_\_\_ 63 Front St \_\_\_\_\_

Cost of Construction \$ \_\_\_\_\_ Building Fee: \_\_\_\_\_

Permit Fee \$ \_\_\_\_\_ Site Fee: \_\_\_\_\_

Certificate of Occupancy Fee: \_\_\_\_\_

Total: 220 \_\_\_\_\_

Building (IL) \_\_\_\_\_ Plumbing (I5) \_\_\_\_\_ Electrical (I2) \_\_\_\_\_ Site Plan (U2) \_\_\_\_\_

Other \_\_\_\_\_

CBL: 16751 \_\_\_\_\_

Check #: 533 \_\_\_\_\_ Total Collected \$ 220 \_\_\_\_\_

**No work is to be started until permit issued.  
Please keep original receipt for your records.**

Taken by: [Signature] \_\_\_\_\_

WHITE - Applicant's Copy  
YELLOW - Office Copy  
PINK - Permit Copy





# General Building Permit Application

If you or the property owner owes real estate or personal property taxes or user charges on any property within the City, payment arrangements must be made before permits of any kind are accepted.

Location/Address of Construction: <u>63 Front St 37 Front St</u>		
Total Square Footage of Proposed Structure/Area	Square Footage of Lot	Number of Stories
Tax Assessor's Chart, Block & Lot Chart# <u>167</u> Block# <u>E</u> Lot# <u>+</u> <u>161</u> <u>B</u> <u>1</u>	Applicant "must be owner, Lessee or Buyer" Name <u>PORTLAND HOUSING</u> Address <u>14 BAYTER ISLAND</u> City, State & Zip <u>PORTLAND</u>	Telephone:
Lessee/DBA (If Applicable) <b>RECEIVED</b> OCT 20 2010	Owner (if different from Applicant) Name Address City, State & Zip	Cost Of Work: \$ <u>20,000</u> C of O Fee: \$ Total Fee: \$ <u>220</u>
Current legal use (i.e. single family) If vacant, what was the previous use?	Number of Residential Units <u>5</u> <u>Multi unit housing - Front steps</u>	
Proposed Specific use:	<u>NEW FRONT STAIRS 10 units</u>	
Is property part of a subdivision? _____ If yes, please name _____	Project description: <u>Replace Existing Front stairs IISLEY # 54,56</u>	
<u>FRONT ST 57,59 - WEST PRESUMPSCOT 24,26,28,30,40,42,</u>		
Contractor's name:	<u>M.R. LABEL</u>	
Address:	<u>6 EASTERN AVE</u>	
City, State & Zip:	<u>FALMOUTH ME</u>	Telephone: <u>797-6051</u>
Who should we contact when the permit is ready:	<u>MARK LABEL</u>	Telephone: <u>650-4020</u>
Mailing address:	<u>6 EASTERN AVE. FALMOUTH ME 04105</u>	

Please submit all of the information outlined on the applicable Checklist. Failure to do so will result in the automatic denial of your permit.

In order to be sure the City fully understands the full scope of the project, the Planning and Development Department may request additional information prior to the issuance of a permit. For further information or to download copies of this form and other applications visit the Inspections Division on-line at [www.portlandmaine.gov](http://www.portlandmaine.gov), or stop by the Inspections Division office, room 315 City Hall or call 874-8703.

I hereby certify that I am the Owner of record of the named property, or that the owner of record authorizes the proposed work and that I have been authorized by the owner to make this application as his/her authorized agent. I agree to conform to all applicable laws of this jurisdiction. In addition, if a permit for work described in this application is issued, I certify that the Code Official's authorized representative shall have the authority to enter all areas covered by this permit at any reasonable hour to enforce the provisions of the codes applicable to this permit.

Signature: Mark Label Date: 10/20/10

This is not a permit; you may not commence ANY work until the permit is issued

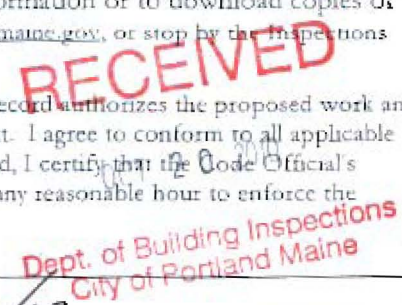

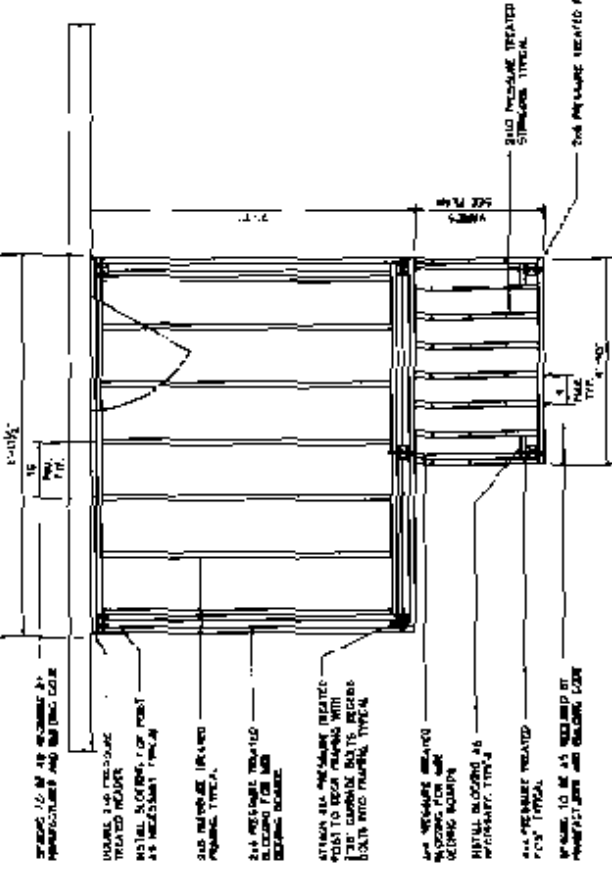

DECK B - PLAN VIEW - FRAMING AND FOOTINGS  
SCALE: 1/8" = 1'-0"

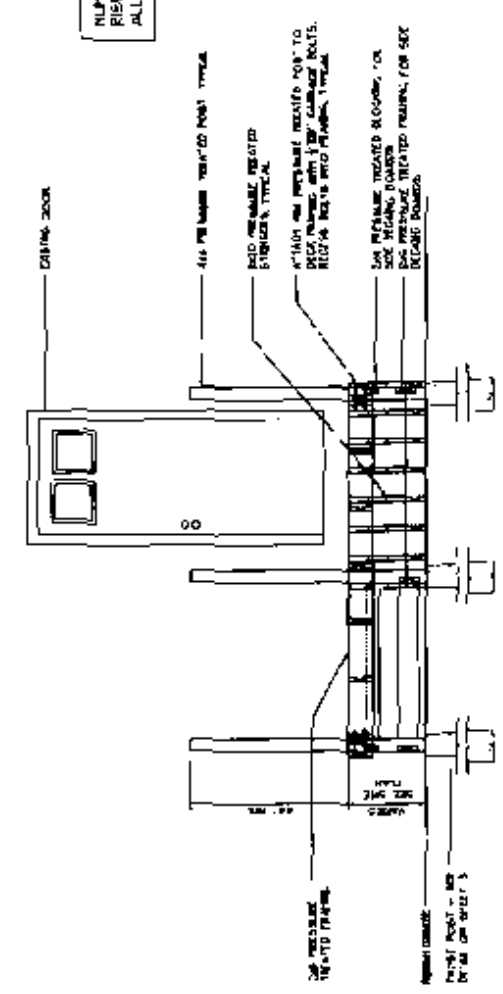

DECK B - FRONT VIEW - FRAMING AND FOOTINGS  
SCALE: 1/8" = 1'-0"

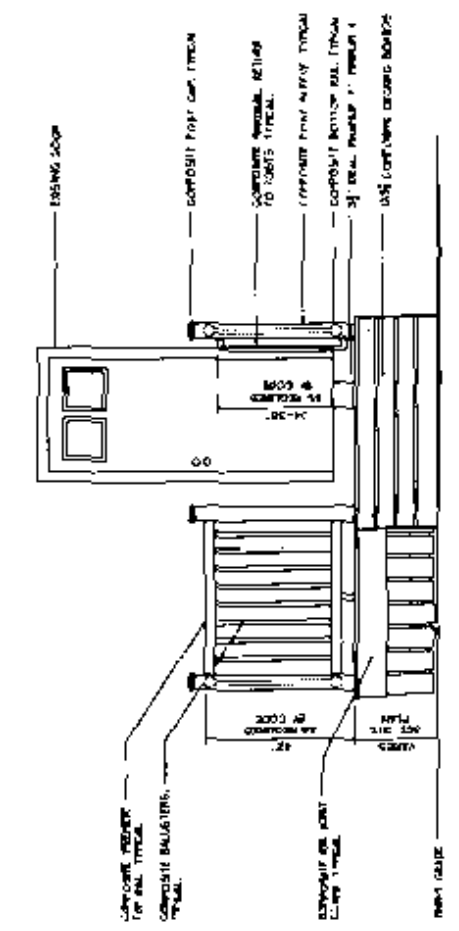

DECK B - FRONT VIEW - DECKING, GUARDRAILS AND HANDRAILS  
SCALE: 1/8" = 1'-0"

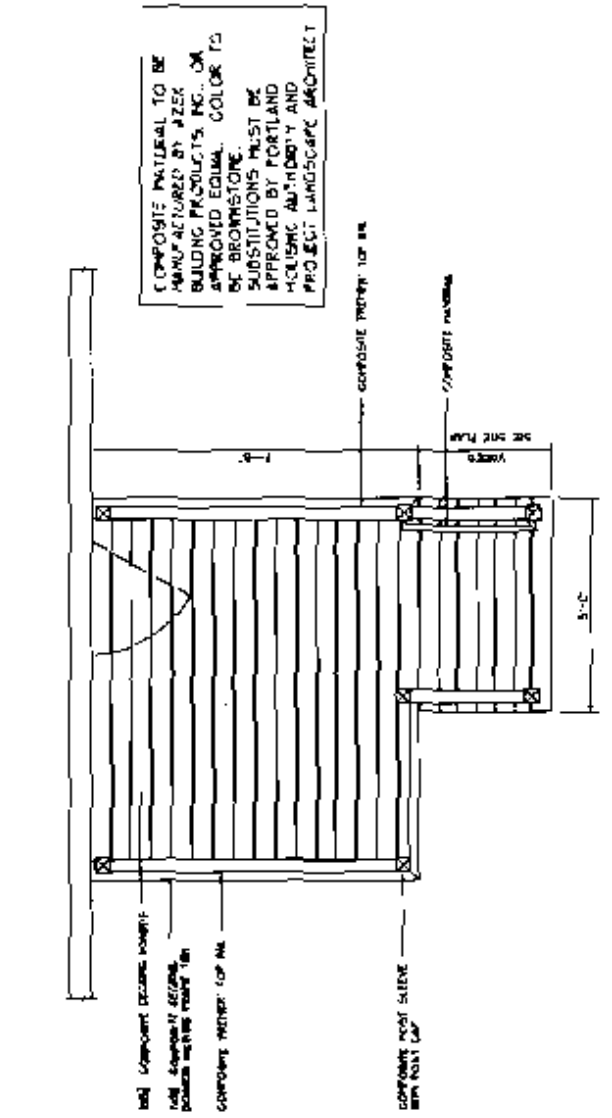

DECK B - FRONT VIEW - DECKING, GUARDRAILS AND HANDRAILS  
SCALE: 1/8" = 1'-0"

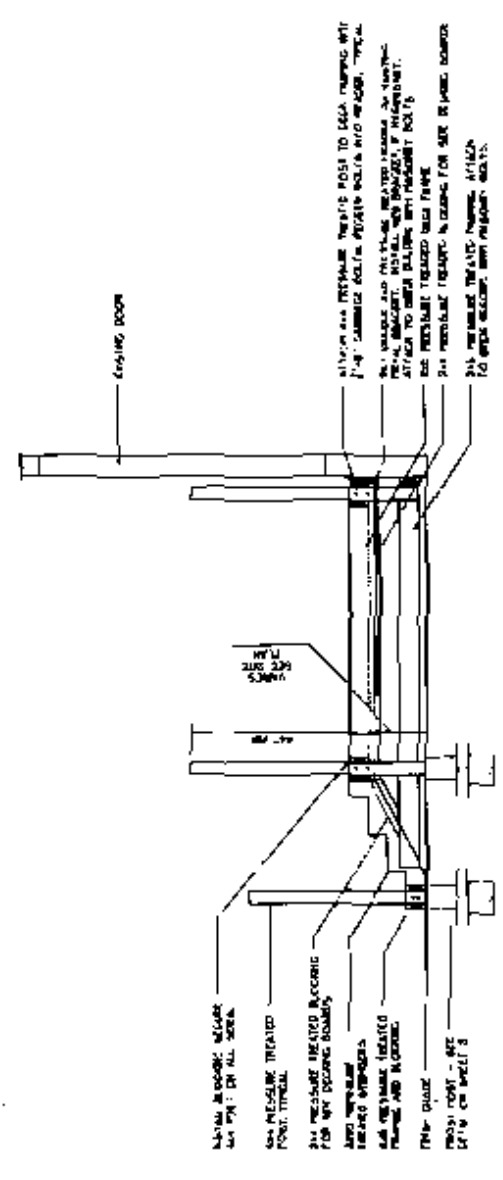

DECK B - SIDE VIEW - FRAMING AND FOOTINGS  
SCALE: 1/8" = 1'-0"

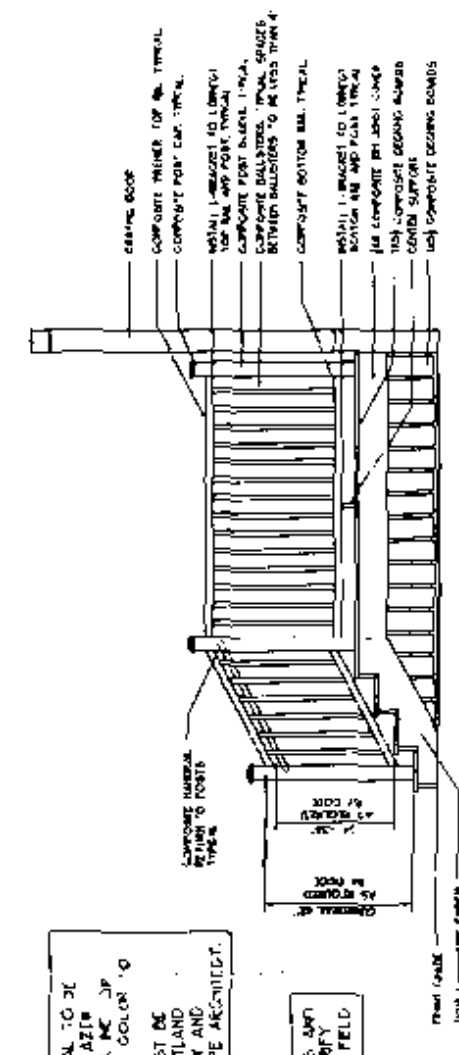

DECK B - SIDE VIEW - DECKING, GUARDRAILS AND HANDRAILS  
SCALE: 1/8" = 1'-0"

Prepared For:  
PORTLAND HOUSING  
AUTHORITY  
1000 NE Oregon Street  
Portland, Oregon 97232  
Contact: Mark Thompson  
Tel: (503) 944-3044

Prepared By:  
MITCHELL & ASSOCIATES  
1000 NE Oregon Street  
Portland, Oregon 97232  
Tel: (503) 944-4487

# FRONT STREET HOUSING DECK IMPROVEMENTS

Front Street  
Portland, Maine

Date: FEBRUARY 6, 2018

Issued For: CONSTRUCTION BIDDING

Revisions:

1. Description of work to be performed will be subject to contract documents and specifications to be published.

2. DECK B DETAILS

Scale: 1/8" = 1'-0"

Sheet No. 7

COMPOSITE MATERIAL TO BE MANUFACTURED BY AZEK BUILDING PRODUCTS, INC. OR APPROVED EQUAL. COLOR TO BE BROWN/STONE. SUBSTITUTIONS MUST BE APPROVED BY PORTLAND HOUSING AUTHORITY AND PROJECT LANDSCAPE ARCHITECT.

NUMBER OF TREADS AND RISERS Varies. VERIFY ALL CONDITIONS IN FIELD.

NUMBER OF TREADS AND RISERS Varies. VERIFY ALL CONDITIONS IN FIELD.

COMPOSITE MATERIAL TO BE MANUFACTURED BY AZEK BUILDING PRODUCTS, INC. OR APPROVED EQUAL. COLOR TO BE BROWN/STONE. SUBSTITUTIONS MUST BE APPROVED BY PORTLAND HOUSING AUTHORITY AND PROJECT LANDSCAPE ARCHITECT.

NUMBER OF TREADS AND RISERS Varies. VERIFY ALL CONDITIONS IN FIELD.

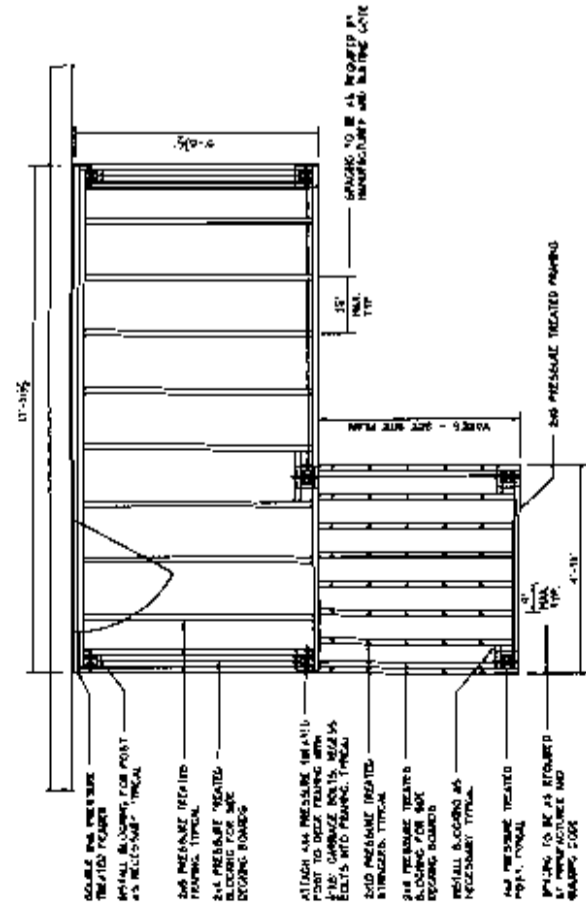

DECK C - PLAN VIEW - FRAMING AND FOOTINGS

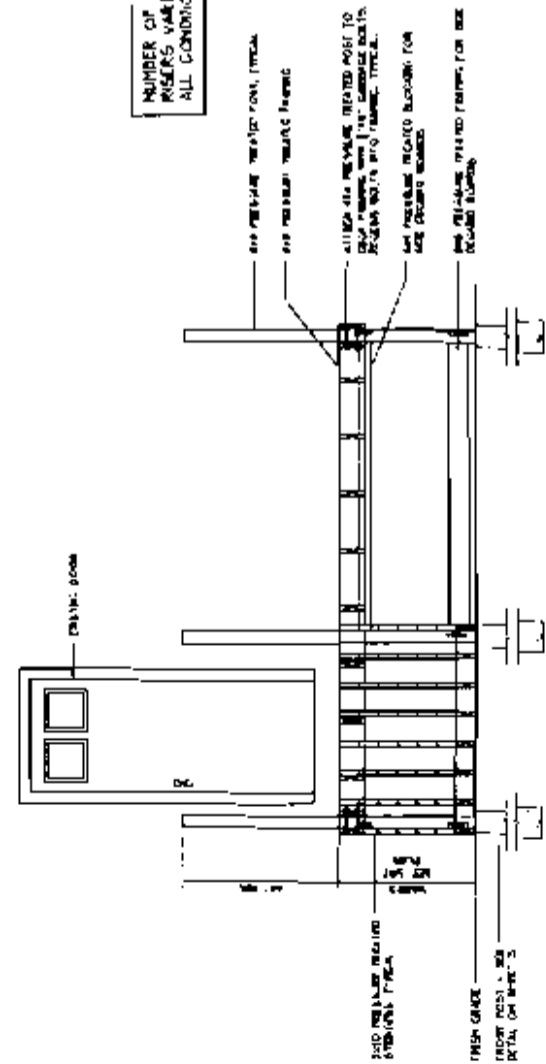

DECK C - FRONT VIEW - FRAMING AND FOOTINGS

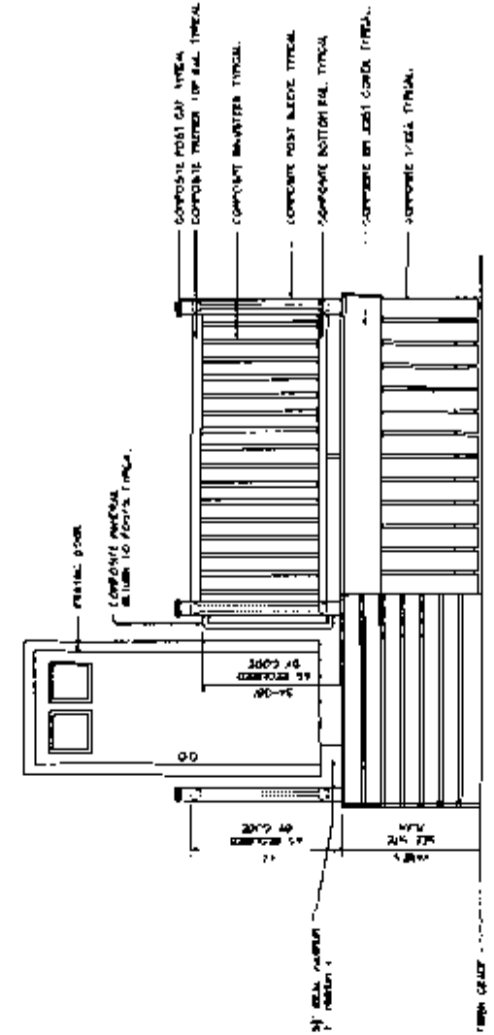

DECK C - FRONT VIEW - DECKING, GUARDRAILS AND HANDRAILS

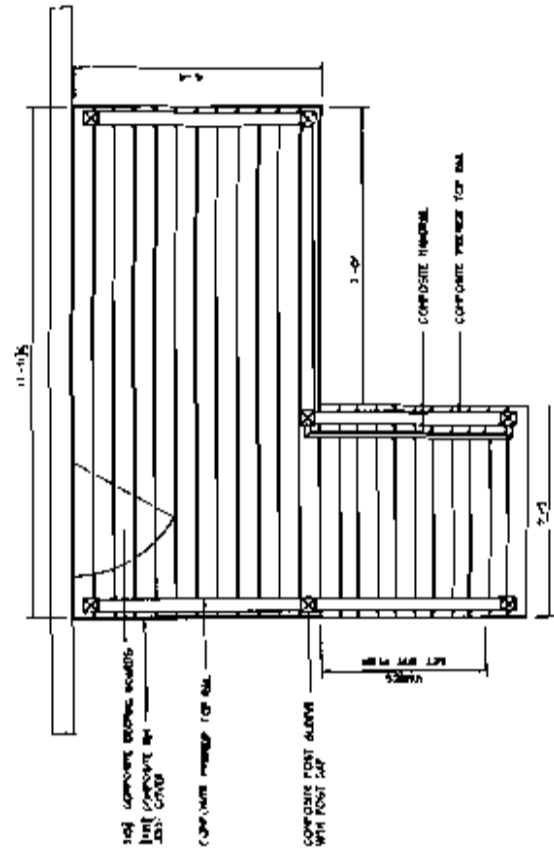

DECK C - PLAN VIEW - FRAMING AND FOOTINGS

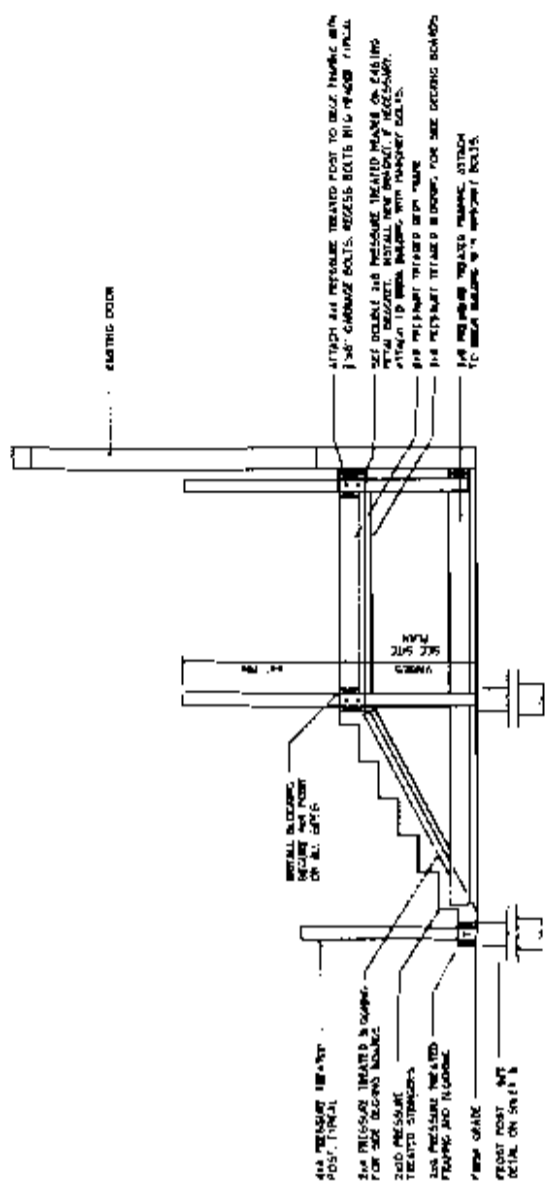

DECK C - SIDE VIEW - FRAMING AND FOOTINGS

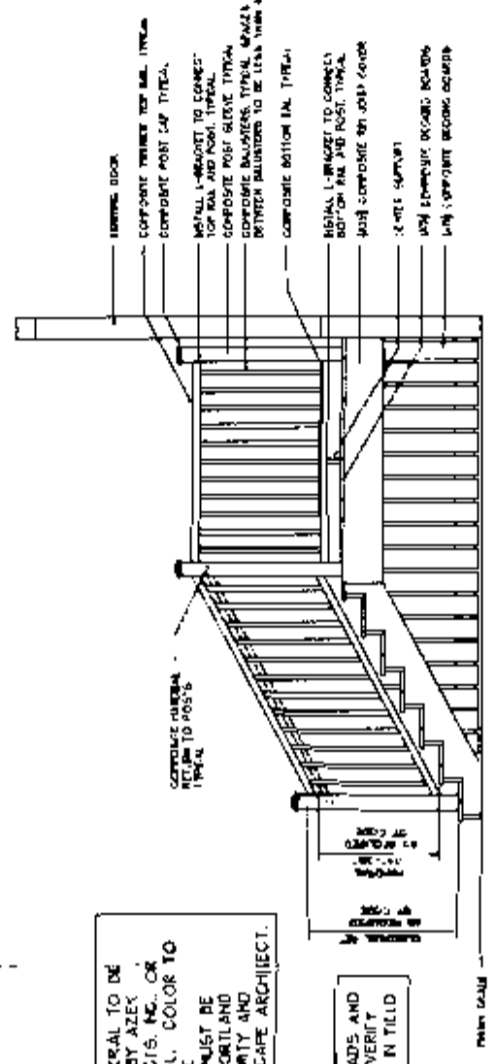

DECK C - SIDE VIEW - DECKING, GUARDRAILS AND HANDRAILS

COMPOSITE MATERIAL TO BE MANUFACTURED BY AZEK BUILDING PRODUCTS, INC. OR APPROVED EQUAL. COLOR TO BE BROWN/STONE. SUBSTITUTIONS MUST BE APPROVED BY PORTLAND HOUSING AUTHORITY AND PROJECT LANDSCAPE ARCHITECT.

NUMBER OF TREADS AND RISERS VARIES. VERIFY ALL CONDITIONS IN FIELD.

COMPOSITE MATERIAL TO BE MANUFACTURED BY AZEK BUILDING PRODUCTS, INC. OR APPROVED EQUAL. COLOR TO BE BROWN/STONE. SUBSTITUTIONS MUST BE APPROVED BY PORTLAND HOUSING AUTHORITY AND PROJECT LANDSCAPE ARCHITECT.

NUMBER OF TREADS AND RISERS VARIES. VERIFY ALL CONDITIONS IN FIELD.

Prepared For:  
PORTLAND HOUSING AUTHORITY  
14 Water Street  
Portland, ME 04101  
Tel: (603) 876-3300

Prepared By:  
MATHIAS & ASSOCIATES  
100 Water Street  
Portland, ME 04101  
Tel: (603) 876-3300

FRONT STREET HOUSING  
DECK IMPROVEMENTS  
Front Street  
Portland, Maine

Date: FEBRUARY 8, 2010  
Issued For: CONSTRUCTION SETTING  
Project: DECK C DETAILS  
Scale: 1/8" = 1'-0"  
Sheet No.: 8





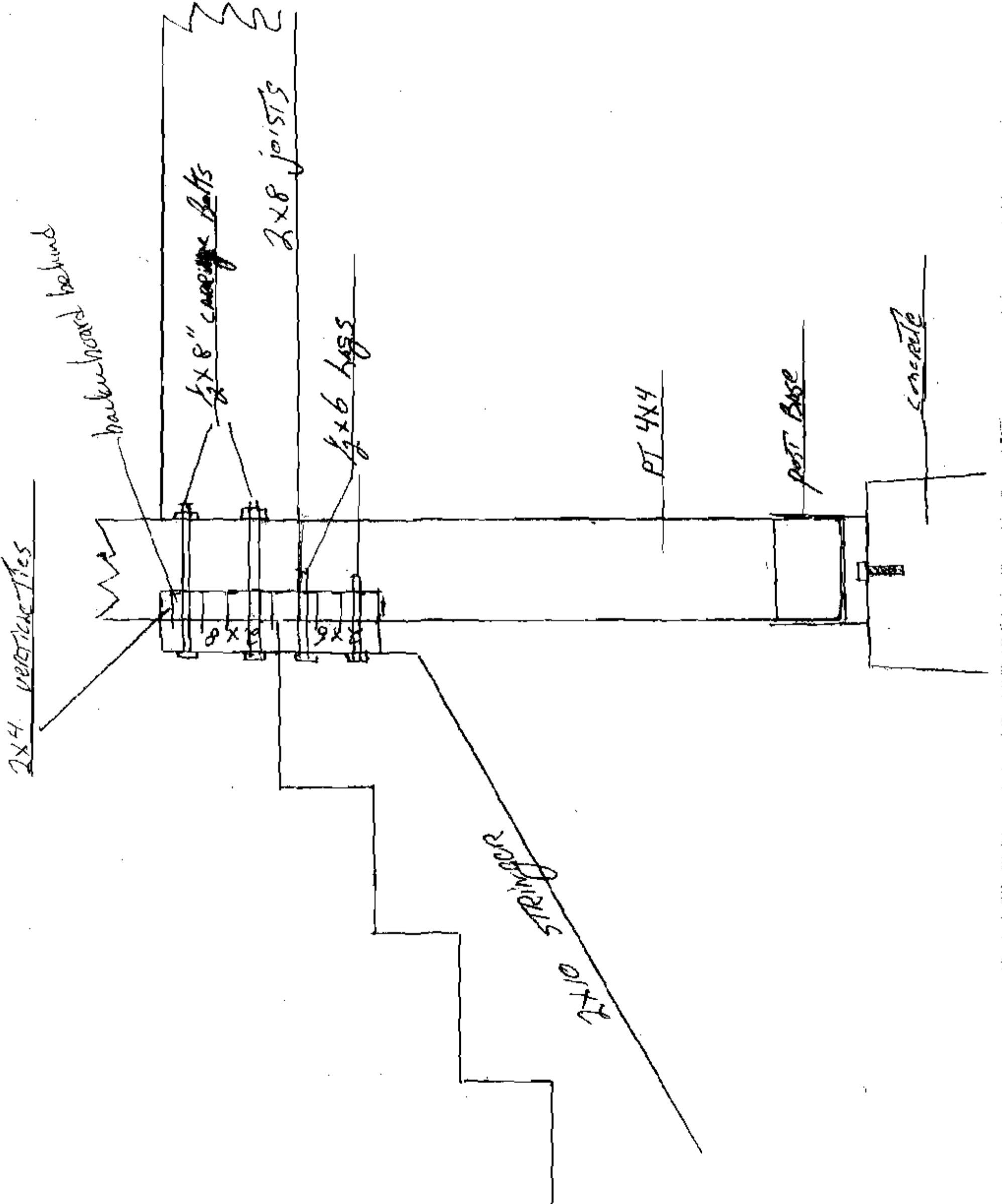

RECEIVED

NOV 23 2010

Dept. of Building Inspections  
City of Portland Maine