

Seaside Rehabilitation Center
Portland, Maine
For Bid
July 18, 2014

SECTION 230000 - HVAC

PART 1 - GENERAL

1.1 DESCRIPTION

- A. The work covered by this Section of the specifications includes the furnishing of labor, materials, equipment, transportation, permits, inspections and incidentals and the performing of operations required to install the heating, ventilating and air conditioning equipment indicated.

1.2 RELATED DOCUMENTS

- A. The drawings and the specifications including SECTION 230500 "Common Work Results for HVAC" are hereby made a part of the work of this section.

1.3 SUBMITTALS

- A. Substitutions: Your attention is directed to Section 230500-"Substitutions", relative to competition and the (ONLY) notation. Familiarity with this section should be achieved before reading the PRODUCTS section of this specification.

- B. The items for which the submittals paragraph in Section 230500 "Common Work Results for HVAC", apply are as follows:

1. Piping and supports.
2. Valves.
3. Hydronic accessories.
4. Miscellaneous materials.
5. Hangers.
6. Cutting and patching.
8. Wall Heaters.
9. Mini-split Heat Pump Systems.
10. Split Air Conditioning Systems.
11. Piping, Valve and Equipment Identification.
12. Firestopping materials and methods.
13. Hydronic Accessories.
14. Outdoor Heat Pump Units.
15. Electric heaters.
16. Fans.
17. Fintube radiation.

PART 2 PRODUCTS

2.1 PIPING MATERIALS

- A. Hot Water Heating Piping (HWS/R): Schedule 40 carbon steel pipe conforming with ASTM A53 or ASTM A106 and with threaded / welded joints and malleable iron fittings, or Schedule 40 carbon steel pipe with rolled or cut grooves and rigid

Seaside Rehabilitation Center

Portland, Maine

For Bid

July 18, 2014

couplings or flexible coupling where required for expansion, or Schedule 05 carbon steel pipe up to 2" with the Victaulic "Pressfit" fitting system.

- B. Branch piping may be PEX tubing.
- C. Condensate Piping: Type L hard copper tubing and cast bronze or wrought copper solder fittings.

2.2 FITTINGS FOR STEEL PIPE

- A. Fittings in sizes 1/2" through 2": Steel or malleable iron with requirements as follows:
 - 1. Steel fittings socket welding or screwed type conforming to ANSI B16.11.
 - 2. Malleable iron fittings screwed type conforming to ANSI B16.3.
 - 3. Victaulic rolled or cut grooves with rigid couplings and flexible couplings where required for expansion.
 - 4. Victaulic "Pressfit" system.
- B. Fittings in sizes 2-1/2" and larger:
 - 1. Butt welding type conforming to ANSI B16.9.
 - 2. Flanged type conforming to ANSI B16.5.
 - 3. Victaulic rolled or cut grooves with rigid coupling and flexible couplings where required for expansion.
- C. Steel Flanges: Forged steel, welding type conforming to ANSI B16.5. Bolting and gaskets shall be as follows:
 - 1. Bolting: Material used for bolts and studs shall conform to ASTM A 307, Grade B, and material for nuts shall conform to ASTM A 194, Grade 2. Dimensions of bolts, studs, and nuts shall conform to ANSI B18.2.1 and ANSI B18.2.2 with threads conforming to ANSI B1.1 coarse type, with Class 2A fit for bolts and studs, and Class 2B fit for nuts. Bolts or bolt-studs shall extend completely through the nuts.
 - 2. Gaskets: Gasket material for flanged joints for steam application under saturated conditions shall be composition asbestos or copper. Gaskets shall be of a material that resists attack by the fluid or gas in the pipeline and shall be suitable for the pressure and temperature ranges encountered. Gaskets shall be as thin as the finish of surfaces will permit. Raised-face steel flanges shall have ring gaskets with an outside diameter extending to the inside of the bolt holes. Gaskets shall have an inside diameter equal to or larger than the port openings.

Seaside Rehabilitation Center
Portland, Maine
For Bid
July 18, 2014

- D. Butt Weld Joints: Shall conform to ANSI B31.1. The use of backing rings shall conform to ANSI B31.1. Ferrous rings shall be of weldable quality and shall not exceed 0.05 percent sulfur. Backing rings shall be of the continuous machined or split band type.
- E. Grooved Joint Couplings: Couplings shall be self-centering and shall engage and lock in place the grooved or shouldered ends of pipe and pipe fittings in a positive watertight couplings where required. The couplings shall provide some degree of angular pipe deflection, contractions, and expansion. The coupling clamp shall be malleable iron conforming to ASTM A 536, Grade 65-45-12. The gasket shall be molded rubber conforming to ASTM D 2000, the "line call-out" number shall be suitable for a water temperature of 230 degrees F. Coupling nuts and bolts shall be steel conforming to ASTM A 183. Grooved fittings shall be malleable iron conforming to ASTM A47, Grade 32510 or ductile iron conforming to ASTM A 536, Grade 65-45-12. Mechanical couplings and fittings shall be of the same manufacturer. Before couplings are assembled, pipe ends and outside of gaskets shall be lightly coated with lubricant approved by the coupling manufacturer to facilitate installation. Couplings shall be Victaulic or Grinnell.

2.3 HANGERS

- A. Adjustable Swivel Hanger: Pipe Sizes 2" and Less: Carpenter and Paterson Fig. 800 conforming to MSS-SP-58, oversize for insulated piping systems. Pipe Sizes Larger Than 2": Carpenter and Paterson Fig. 100, oversize for insulated piping systems.
- B. Riser Clamp: Carpenter and Paterson Fig. 126 and Fig. 126 CT conforming to MSS-SP-58, provide copper plated clamps on copper pipes.
- C. Spring Vibration Isolation Pipe Hangers: Mason Industries Model PC30N, or approved equal by Amber-Booth or Vibration Mountings and Controls, combination spring and double deflection bridge-bearing neoprene hangers, 1" static deflection.

2.4 VALVES

- A. Ball Valves: Apollo 70-100 Series, bronze body, Watts, or equal, Fed. Spec. WW-V-35, Type II, Class A (bronze), Style 3, blow-out proof stem, 600 pound W.O.G., screwed connection for steel pipe, sweat connection for copper tube. Provide stem extension to allow operation without interfering with pipe insulation. Provide Tee handles for valves thru 2" pipe size.
- B. Gate Valves: Nibco Model S-113 or T-113, Watts, or equal, bronze body Fed. Spec. WW-V-54, wedge disc, rising stem, screwed connection for steel pipe, sweat connection for copper tube, 150-pound class.
- C. Outside Screw and Yoke (OS&Y) Gate Valves: Nibco Model F-617-0, Watts, or equal, iron body, Fed. Spec. WW-V-58 with bronze trim, 125 pound class.
- D. Check Valves: Nibco Model S-413 or T-413, bronze body Fed. Spec. WW-V-51, regrinding swing check type, 200 pound class.

Seaside Rehabilitation Center
Portland, Maine
For Bid
July 18, 2014

- E. Butterfly Valves: Centerline or Norris, valves shall conform with MSS-SP67, Type I 150 psig - Tight shut off valve, ends shall be flangeless or grooved, cast iron body, type 300 series corrosion resistant steel stems and corrosion resistant or bronze discs with molded elastomer disc seals. Valves shall have throttling handles with a minimum of 7 locking positions. Valves shall be suitable for water temperatures up to 220 degrees F.

2.5 PIPING, VALVE AND EQUIPMENT IDENTIFICATION

- A. Pipe Identification: Provide plastic "wrap around" identification markers by Seton or Setmark indicating flow direction and fluid flowing for the following:

Hot Water Supply Piping
Hot Water Return Piping
Refrigerant Piping

1. Markers shall be placed 30-50 ft. apart for piping in accessible areas.
2. Markers shall be placed outside the pipe insulation and in the most obvious location for viewing. Markers shall not be installed in exposed areas except in the mechanical rooms.
3. Piping identification shall be color-coded and in accordance with ANSI.

- B. Equipment Identification:

1. Provide laminated plastic nameplates for boilers, pumps, and air handling units. Laminated plastic shall be 0.125-inch thick melamine plastic conforming to Fed. Spec. L-P-387, black with white center core. Surface shall be a matte finish, corners shall be square. Accurately align lettering and engrave into the white core. Minimum size of nameplates shall be 1.0 inch by 2.5 inches. Lettering shall be minimum of 0.25-inch high normal block lettering.

- C. Valve Tags:

1. Attach to each valve a 1-1/2" round or octagonal brass tag with 1/2" indented numerals filled with a durable black compound. In addition to the valve numbers, each tag shall identify the system it controls. Service stop valves exposed in finished areas need not be tagged.
2. Tags shall be securely attached to stems of valves with copper or brass "S" hooks, or chains.
3. Valve charts shall be provided for each piping system and shall consist of schematic drawings of piping layouts, showing and identifying each valve and describing its function. Upon completion of the work, one (1) copy of each chart, sealed to rigid backboard with clear lacquer placed under glass and framed, shall be hung where directed. Two (2) additional unmounted copies shall be delivered to the Owner.

Seaside Rehabilitation Center
Portland, Maine
For Bid
July 18, 2014

2.6 HYDRONIC SPECIALTIES

- A. Thermometers: Tel-Tru Model D5A-series battery operated, or Ashcroft, 5" round dial, adjustable angle, Type 304 stainless steel case. The digital display shall include 1" high LCD digits. The thermometer display shall be in ⁰F. and have a minimum battery life of five (5) years. Accuracy shall be +/- 1% of the displayed value or 1⁰, whichever is greater. Provide with heat transfer fluid to fill the sealed interstitial space between bulb and well. Evidence of the transfer fluid leaking shall be cause for refilling and sealing the well.
- B. Pressure Gauges: Tel-Tru, or Ashcroft Type 1005, Grade B, ANSI B40.1, 3-1/2" diameter face installed with shut off petcock and restrictor. Pressure range: 0-60 psig with 5 psi graduations.
- C. Strainers: Watts Model 77S, Nibco, MIL-S-16293, 125 psig minimum rating wye strainers, cast iron or bronze body, screen shall be stainless steel, monel or bronze with 20 mesh perforations. Provide with blowdown ball valve and 3/4" hose connection.
- D. Automatic Air Vents: Armstrong No. 1-AV, float type to vent air in hydronic systems. Vents shall be constructed with cast iron body and stainless steel internals and with NPT male inlet and outlet for 1/4 inch overflow for safe water connection. 150 psi working pressure, 250°F maximum temperature.
- E. Manual Air Vents: Brass body, fiber discs, 125 psi working pressure, 240°F maximum temperature, adjustable for quick venting at system start-up.
- F. Temperature and Pressure Test Ports: Peterson Equipment Co. Model 110 "Pete's Plugs" temperature and pressure test capability, brass body, 1/4" NPT fitting, Nordel valve cores, 275°F maximum temperature, 500 psig maximum pressure. Provide with (1) pressure and temperature test kit.
- G. Flexible Connections at Coils: Mason type BSS line size with male nipples for 2" and smaller, flanged for 2-1/2" and larger. Provide series EM-RF-150 for application of extreme movement (3/4") or misalignment (1-1/2").
- H. Temperature and Pressure Test Ports: Peterson Equipment Co. Model 110 "Pete's Plugs" temperature and pressure test capability, brass body, 1/4" NPT fitting, Nordel valve cores, 275°F maximum temperature, 500 psig maximum pressure. Provide with (1) pressure and temperature test kit.
blow-down valve.
- I. Automatic Flow Control Valves: Flow Design, Inc., Autoflow Model AC (up to 2") and Model WS (larger than 2"), Griswold, Nexus, or approved equal. The valves shall be factory set to maintain the specified flow rates within +/- 5% over an operating range of 2-32 psid. Each valve shall have a five (5) year warranty and free first year cartridge exchange. The internal wear surfaces of the valve cartridge shall be electroless nickel or stainless steel. The valve body shall be forged brass and permanently marked with the flow rate and spring range. Minimum pressure and

Seaside Rehabilitation Center
Portland, Maine
For Bid
July 18, 2014

temperature ratings shall be 400 psig at 250°F. Valve accessories shall include a union and pressure and temperature test ports. Installation shall be in accordance with the manufacturer's recommendations. The ball valve shall have a teflon packing, brass packing nut and blowout-proof stem, large diameter plated ball and a full size steel handle with vinyl grip. Provide an automatic flow control valve for each terminal heating unit as indicated on the drawings.

2.7 FANS

- A. Shall be model indicated. Fan manufacturers shall be Greenheck, Cook or equal. The fans shall include housing, fan wheel, shaft, bearings, inlet shroud, motor, mounting support and mounting frame as a factory-assembled unit. An OSHA-approved belt guard for each fan shall be included. The fan drive shall have a 1.5 service factor for the maximum rated horsepower. Provide a disconnect switch for each fan. Roof and sidewall fans shall have an aluminum housing and a factory-applied epoxy coating with color selection by the Engineer. Provide gravity-operated, gasketed backdraft dampers for all exhaust fans except Kitchen Hood fans.
- B. Bearings shall be precision, flange-mounted self-aligning ball bearings at inlet and discharge. Minimum average L50 design life shall be 200,000 hours at maximum catalogued operating conditions. Grease lines shall extend to the exterior of the fan housing.
- C. Submit sound power data for inlet and discharge sound.
- D. Submit fan curves for each fan with the design operating point clearly marked.
- E. Belt-driven fans shall have "Grip-Notch" belts and automatic belt tensioner. Roof curbs shall have gaskets.

2.8 TOTAL ENERGY HEAT RECOVERY EQUIPMENT (ERV-#)

- A. Shall be Lifebreath, or approved equal, with capacities and performance as scheduled. The heat recovery equipment shall be a factory assembled and tested package, constructed and rated in accordance with ARI, AMCA and UL. System components shall include fan(s), air-to-air heat exchangers, dampers, filter sections, motor starters, welded structural steel base, non-fused disconnect switches, controls (coordinate with the Controls Contractor). The casing shall have 1" thick (minimum) 3.0 pcf fiberglass thermal insulation.
- B. The air-to-air "total energy" heat recovery units shall be a plate type heat exchanger certified by AHRI under Standard 1060 and listed under UL 1812 "Standard for Ducted Air to Air Heat Exchangers", capable of sensible and latent energy transfer. The unit shall perform without frosting at -10F., and 40% RH. The heat exchanger shall have a five (5) year replacement warranty for materials and labor.
- C. Fans shall be DWDI forward curved or airfoil blade or plenum fan with variable pitch belt drives selected at 1.5 times the maximum rated motor horsepower. Motors shall be mounted on an adjustable slide base. Motors shall be premium high efficiency, inverter-duty rated. Motor performance shall comply with the 2009 American Recovery and Reinvestment Act. Fan bearings shall be regreasable

Seaside Rehabilitation Center
Portland, Maine
For Bid
July 18, 2014

tapered roller pillow block bearings with an L10 life of 200,000 hours. Provide extended lubrication lines for each bearing. All serviceable components shall be readily accessible via hinged (stainless steel) and latched fully gasketed quick release access doors.

- D. Provide Supply and exhaust prefilters shall be 2" thick, 60-65% efficient (MERV7) extended surface pleated media disposable type by Farr, or approved equal. Furnish a total of three (3) complete sets of filters for each filter bank.
- E. Motorized intake and exhaust dampers shall be galvanized steel, airfoil blade, Ruskin Model CD60, or approved equal, "ultra low leak, insulated" type. Blade seals shall be neoprene and jamb seals shall be compressible aluminum or stainless steel. Insulated, motorized backdraft dampers and actuators with end switches shall be provided for the supply and exhaust fans. Dampers shall comply with the IECC 2012 and ASHRAE 90.1-2013.
- F. Electrical work shall be in accordance with the National Electrical Code (NFPA 70) and shall include disconnects, motor starters, and junction boxes. Wiring shall be in galvanized steel or liquidtight conduit. A single point electrical connection shall be provided.
- G. The heat recovery units shall be started up and their operation verified by an authorized representative of the equipment manufacturer.

2.9 SPLIT SYSTEM AIR CONDITIONING UNITS (**SAC-IT, SCU-IT**)

- A. The split system air conditioning units shall be Samsung with capacities and performance as scheduled, R410A, heat pumps with inverter driven compressors, wall mounted indoor units, as indicated with outdoor units. Furnish each unit with a wired wall-mounted controller. Cooling capacity shall be as scheduled with entering conditions of 75⁰F. EDBT, 67⁰F. EWBT and 95⁰F. ambient. The indoor units shall operate on 208V. and the outdoor units shall operate on 208V.-1 phase power. Furnish with **integral "Maxi-Blue" or "Mini-Blue"** condensate pumps by Charles Austen Pumps, LTD, size as required, condensate overflow safety switches, refrigerant piping, pipe insulation, wiring and condensate piping as recommended by the manufacturer. Furnish with wired controllers. The air conditioning units shall be suitable for cooling operation at 0⁰F. outside ambient. Indoor units shall be wall-mounted, as indicated.
- B. The units shall be suitable for refrigerant line lengths of up to 150 feet between the indoor evaporator and the outdoor condensing unit. Outdoor units shall be set on a reinforced concrete pad. The indoor units shall be piped in an aesthetically pleasing manner with a minimum of exposed piping. Exposed piping shall have a finished molded PVC cover. Installation shall be per the manufacturers recommendations.

2.10 VARIABLE REFRIGERANT VOLUME SYSTEM (**SAC-1a, 1b, 1c, 1d, SCU-1**)

- A. Indoor unit (4) shall be Daikin Model Number FXZQ18M7VJU, Mitsubishi, or LG, to be connected to outdoor unit Daikin Model Number RXYQ72PBTJ, Mitsubishi, or LG heat pump. The indoor units shall be a four-way air distribution type with a

Seaside Rehabilitation Center
Portland, Maine
For Bid
July 18, 2014

washable decoration panel. The supply air is distributed via motorized louvers which can be horizontally and vertically adjusted from 0° to 90°. The units shall be equipped with a programmed drying mechanism that dehumidifies while limiting changes in room temperature when used with Daikin remote control BRC1E72. A condensate pan shall be located under the coil in each unit. Units shall be equipped with a factory mounted condensate pump capable of 21" of lift. The outdoor condensing unit heat pump shall have a variable speed inverter compressor and variable speed condenser fan. The system shall be controlled by the Daikin BRC1E72 navigational controller and shall be capable of auto changeover and night setback. The outdoor unit shall be set on a reinforced concrete pad. Indoor units shall have a condensate overflow safety switch interlocked with the fan. The manufacturer shall provide a factory trained technician to perform start up of the system and train Owners personnel in system operation.

2.11 FINTUBE RADIATION

- A. FTR: Fintube radiation (FTR) shall be Sterling "Versaline" Model JVK-S11, or Vulcan, sloped top, wall-mounted, performance as scheduled, with an output rating of 480 BTUH/ft. with 160⁰F entering water temperature, 65⁰F entering air temperature and a 2.0 GPM water flow rate. The finned element shall be 3/4" copper tube with aluminum fins at 40 fins per foot. The enclosure shall be 16 gauge cold rolled steel, 4" deep x 11" high with factory enamel finish and color selection by the Architect. Installation including mounting height shall be per the manufacturer's recommendations, or as scheduled. Furnish with allen screw operated dampers.

PART 3 EXECUTION

3.1 SURFACE CONDITIONS

- A. Inspection:
 - 1. Prior to work of this Section, carefully inspect the installed work of other trades and verify that such work is complete to the point where this installation may properly commence.

3.2 CLOSING IN WORK

- A. Cover up or enclose work after it has been properly and completely tested and reviewed.
- B. No additional cost to the Owner will be allowed for uncovering or recovering any work that is covered or enclosed prior to required test and review.

3.3 TEST AND ADJUST

- A. After the installation is complete and ready for operation, test the system under normal operating conditions in the presence of the Engineer and demonstrate that the system functions as designed.

Seaside Rehabilitation Center
Portland, Maine
For Bid
July 18, 2014

- B. Correct defects which develop in operational testing, conduct additional testing until defect free operation is achieved.

3.4 CLEANUP AND CORROSION PREVENTION

- A. Piping and equipment shall be thoroughly cleaned. Dirt, dust, and debris shall be removed and the premises left in a clean and neat condition.
- B. Before covering is applied to piping systems, clips, rods, clevises and other hanger attachments, and before uncovered piping is permitted to be concealed, corrosion and rust shall be wire brushed and cleaned and in the case of iron products, a coat of approved protective paint applied to these surfaces. When corrosion is from the effects of hot solder paste, the areas shall be cleaned and polished and a wash of bicarbonate of soda and water used to neutralize the acid condition.

3.5 INSTRUCTIONS

- A. On completion of the project, instruct the Owner's representative in the care and operation of the system. The total period of instruction shall not be less than two (2) hours. The time of instruction shall be arranged with the Owner. In addition to the prime Mechanical Contractor, the control system Contractor, Balancing Contractor, and Owner's representative shall be present and participate in the Owner's instruction.

3.6 FIRESTOPPING

- A. Firestopping shall be performed in accordance with "Firestopping" specification section. All penetrations of fire-rated assemblies including walls and floors by mechanical system components (piping, ductwork, conduits, etc.) shall be firestopped as specified.

3.7 REFRIGERATION PIPING

- A. Refrigeration Piping:
 - 1. Provide and install refrigeration piping, hangers, and accessories as specified and required. The piping installation shall be performed by a qualified refrigeration mechanic under the direct supervision of the equipment manufacturer. Submit records of tests.
 - 2. Refrigeration piping shall be Type ACR copper tube with brazed joints, or as recommended by the equipment manufacturer, nitrogen-charged equal to BCUP-2 Classification of American Welding Society.
 - 3. The refrigeration system shall be tested as follows:

High pressure Side	300 psi
Low Pressure Side	150 psi
 - 4. Support risers, offsets, and equipment, in an acceptable manner.

Seaside Rehabilitation Center
Portland, Maine
For Bid
July 18, 2014

5. Piping shall be installed to meet Codes and regulations, applicable to the installation and in accordance with the best practice of the trade. Brazing shall be accomplished while sweeping piping with nitrogen.
6. Refrigerant accessories shall include required valves and fittings to provide a complete installation. Refrigerant suction and hot gas piping shall be insulated with 1½" thick Armaflex Type AP, or equal, elastomeric unicellular insulation. Exterior insulation shall have .032" thick circumferentially corrugated aluminum jacketing by Childers, .030" thick solvent-welded ultraviolet resistant PVC jacketing by Speedline, or approved equal.
7. Parts of the system not factory charged and field installed piping of components shall be evacuated to within .10 MM/Mercury of a perfect vacuum. Break the vacuum to 0 psig with oil-free nitrogen before charging. Hold vacuum overnight for leak test.
8. Provide complete charges of refrigerant and oil to be maintained for the guarantee period.
9. Elbows shall be long radius.
10. The installation shall be in accordance with the above, with equipment manufacturer's instructions, and with established recommended practices.
11. System installation shall include the following:
 - a. Pitch lines down in direction of flow a minimum of 1/2 inch per 10 feet.
 - b. Trap suction risers as verified with the equipment manufacturer.
 - c. Provide service valves on liquid and suction piping at air cooled condensing units.
 - d. Maximum filter-dryer pressure drops:
1 psi for liquid line filter-dryer.
 - e. Liquid line solenoid valve on each refrigeration circuit.
 - f. Thermal expansion valve on each refrigeration circuit.

3.8 INSTALLATION OF PIPING

- A. In general, piping shall be run concealed above ceilings in occupied areas. Piping in other areas may be run exposed. Piping shall not be exposed in occupied spaces unless written authorization is given by the Engineer.
- B. Provide and erect in accordance with the best practice of the trade piping shown on the Drawings and as required to complete the intended installation. Make offsets as shown or required to place piping in proper position to avoid other

Seaside Rehabilitation Center
Portland, Maine
For Bid
July 18, 2014

work and to allow the application of insulation and finish painting to the satisfaction of the Engineer.

- C. The size and general arrangements, as well as the methods of connecting piping, valves, and equipment, shall be as indicated, or so as to meet the requirements of the Engineer.
- D. Piping shall be erected so as to provide for the easy and noiseless passage of heating fluid under working conditions. Inverted eccentric reducing fittings shall be used whenever water pipes reduce in size.
- E. Water mains shall be run level or pitch slightly upward so that no air pockets are formed in the piping. The mains shall be set at elevations such that the runouts feeding equipment shall have no pockets where air can collect except where vents are provided. Provide drains at low points in the piping systems.
- F. High points in water piping shall be provided with manual vents.
- G. In the erection of water piping, make proper allowances for expansion and contraction. Piping shall be anchored as necessary to control expansion. Hot water runouts to units shall be the size as indicated on the Drawings and shall come off the main downward or off the side with a minimum of two 90° elbows provided on runout from main.
- H. Install stop valves and unions to facilitate isolation and removal of equipment. Provide final connections for hydronic specialties furnished under other sections of the Specifications.
- I. Steel piping with screwed connections. Threads on piping shall be full length and clean-cut with inside edges reamed smooth to the full inside bore. Close nipples shall not be used. Pipe threads: standard pipe threads, machine cut and full length. Pipe: reamed to remove burrs and up-ended and rapped to dislodge dirt and scale. Joint compound shall be applied to male thread only. If it is necessary to back off a screwed joint after it is made, the thread shall be cleaned and new compound applied. Caulked threads will not be permitted.
- J. Connections between copper and steel piping shall be made with bronze fittings.
- K. Install thermometer wells for temperature gauges and sensors, projecting a minimum of 2" into the pipe with extension to face of insulation. Piping 1-1/2" and smaller shall be enlarged to 2" where wells are installed. Wells shall be installed in active sections of piping. Fill wells with heat transfer fluid.
- L. Solder joints shall be made with non-lead solder. Clean surfaces to be soldered and use a paste flux. Wash joints with sodium bicarbonate and water to remove corrosive effects of heated solder paste. Hot wipe solder at each fitting.
- M. PVC piping shall have solvent welded joints except at connections to equipment and valves which shall be screwed for sizes 2" and smaller and flanged for sizes 2-1/2" and larger. Solvent welded joints: Pipe ends deburred, and beveled. Pipe end and fitting: Cleaned and dried, primed to soften bonding surfaces. Pipe end:

Seaside Rehabilitation Center
 Portland, Maine
 For Bid
 July 18, 2014

Apply even full layer of solvent cement after priming. Before cement starts to set, insert pipe end into fitting and turn 1/4 turn to evenly distribute cement. Hold joint together until cement sets-up, wipe excess cement off joint.

- N. Pipe penetrations through walls, floors and ceilings shall be in accordance with Section 15000 "Common Work Results for HVAC". Traverse points of piping shall be escutcheoned with split chrome floor and ceiling plates and spring anchors, where visible to occupancy.
- O. Automatic Air Vents: Shall be installed with a manual isolation valve. The vent discharge shall be piped to a local floor drain.

3.9 PIPE HANGERS

- A. Impact driven studs are not acceptable.
- B. Pipes (copper or steel) shall be supported at intervals and rod sizes as follows, double nuts on hangers and on beam clips.

Pipe Size	Hanger Intervals	Rod Sizes
1/2"	5'	3/8"
3/4"	6'	3/8"
1"	7'	3/8"
1-1/4"	8'	3/8"
1-1/2"	9'	3/8"
2"	10'	3/8"
2-1/2"	11'	1/2"
3"	12'	1/2"

- C. Verticals: Supported at the base and at intervals as follows by use of clamp hangers:

Steel Pipe: Not more than 16 ft.

Copper Pipe and Tubing:

1-1/2" and larger - Not more than 12 ft.
 1-1/4" and smaller - Not more than 6 ft.

- D. Provide welded steel saddles at each hanger on steel piping systems 4" and larger.
- E. PVC Piping: Supported at 4' intervals.

APPENDIX
VARIABLE REFRIGERANT VOLUME SYSTEM PERFORMANCE

Submittal Data Sheet

Project Name: Seaside Village
 Location: Portland, ME
 Engineer: Bennett Engineering
 Submitted to: _____
 Submitted by: _____
 Reference: _____

Approval: _____
 Date: _____
 Construction: _____
 Unit #: _____
 Drawing #: _____

Performance

Indoor Unit Model No: FXZQ18M7VJU
 Rated Cooling Capacity (Btu/hr): 18000
 Sensible Capacity (Btu/hr): 13000
 Cooling Input Power (kW): 0.128
 Rated Heating Capacity (Btu/hr): 21000
 Heating Input Power (kW): 0.122

Indoor Unit Type: 2' x 2' 4 Way Cassette
 Rated Cooling Conditions: Indoor: 80°F DB/67°F WB
 Ambient: 95°F DB/75°F WB
 Rated Heating Conditions: Indoor: 70°F DB/60°F WB
 Ambient: 47°F DB/43°F WB
 Rated Piping Length (ft): 25
 Rated Height Separation (ft): 0

Indoor Unit Details

Power Supply (V/Hz/Ph): 208-230/60/1ph
 Power Supply Connections: L1, L2, Ground
 Min. Circuit Amps MCA (A): 0.9
 Max. Overcurrent Protection (MOP) (A): 15
 Dimensions (HxWxD): 11 1/4x22 5/8x22 5/8
 Panel (HxWxD): 2 5/32x27 9/16x27 9/16
 Net Weight (lbs): 42
 Net Weight with Panel (lbs): 48

Airflow Rate (CFM wet coil): 495//353
 Moisture Removal (pt/h): _____
 Gas Pipe Connection (inch): 1/2
 Liquid Pipe Connection (inch): 1/4
 Condensate Connection (inch): 1-1/32
 Sound Pressure Level (dBA): 41
 Sound Power Level (dBA): _____
 External Static Pressure/Max (inWg): 0 / 0
 Controller Name: _____



FXZQ18M7VJU

Std U.S. Warranty: 7yrs Compressor, 1yrs Parts

Project Name: _____
 Location: _____
 Engineer: _____
 Submitted to: _____
 Submitted by: _____
 Reference: _____

Approval: _____
 Date: _____
 Construction: _____
 Unit #: _____
 Drawing #: _____

Dimensional Drawing - Indoor Unit

FXZQ18M7VJU

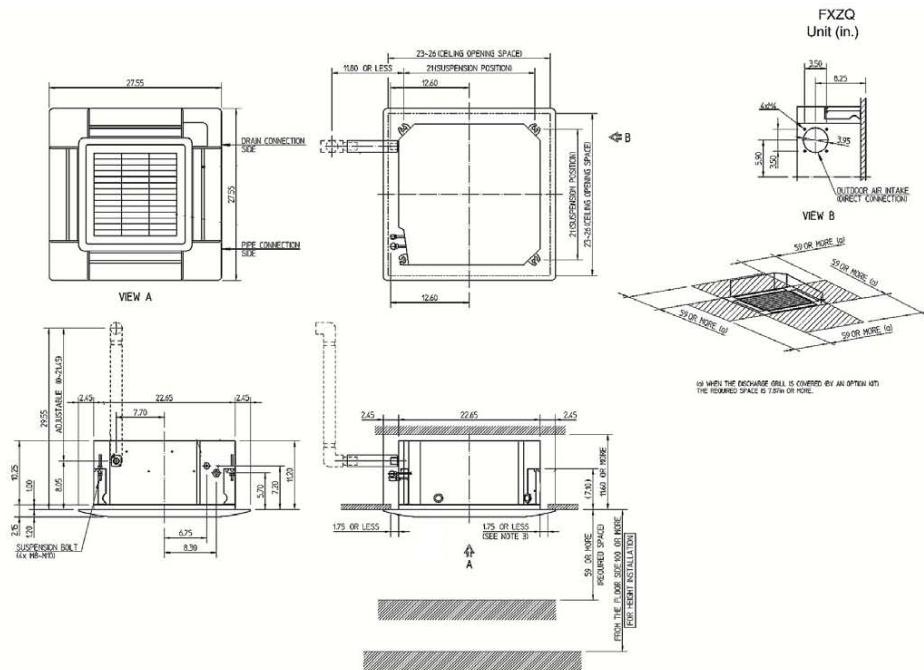



Submittal Data Sheet

Project Name: Seaside Village
 Location: Portland, ME
 Engineer: Bennett Engineering
 Submitted to:
 Submitted by:
 Reference:

Approval:
 Date:
 Construction:
 Unit #:
 Drawing #:

Performance

Outdoor Unit Model No: RXYQ72PBTJ
 Type: Non-Ducted / Ducted
 Rated Cooling Capacity (Btu/hr): 69000
 Nom Cooling Capacity (Btu/hr): 72000
 Cooling Input Power (kW): 5.39
 SEER: N/A
 IEER: 25.8/21.5
 Rated Heating Capacity (Btu/hr): 77000
 Nom Heating Capacity (Btu/hr): 81000
 Heating Input Power (kW): 6.08
 Heating COP (Btu/hr / Btu/hr): 4.0/3.71
 HSPF: N/A
 Heating COP 17F (Btu/hr / Btu/hr): 2.65/2.4

Condensing Unit Type: 6-Ton VRV-III Heat Pump

Unit Combination: RXYQ72PBTJ

Rated Cooling Conditions
 Indoor: 80°F DB/67°F WB
 Outdoor: 95°F DB/75°F WB

Rated Heating Conditions
 Indoor: 70°F DB/60°F WB
 Outdoor: 47°F DB/43°F WB

Rated Piping Length (ft): 50 / 25
 Rated Height Difference (ft): 0

Condensing Unit Details

Power Supply (V/Hz/Ph): 208-230/60/3ph
 Power Supply Connections: L1, L2, L3 Ground
 Min. Circuit Amps MCA (A): 30
 Max. Overcurrent Protection (MOP)(A): 35
 Max. Starting Current MSC(A): -
 Rated Load Amps RLA (A): 14.2
 Dimensions Height (Inch): 66-1/8
 Dimensions Width (Inch): 36-5/8
 Dimensions Depth (Inch): 30-1/8
 Net Weight (lbs): 420

Compressor Type: Inverter
 Capacity Control Range (%): 20 - 100
 Capacity Index Limit: 36 - 93.6 (130%)
 Airflow Rate (CFM): 6530
 Gas Pipe Connection (inch): 3/4
 Liquid Pipe Connection (inch): 3/8
 H/L Pressure Connection (inch):
 H/L Equalizing Connection (inch):
 Sound Pressure Level (dBA): 57
 Sound Power Level (dBA):
 Max. No. of Indoor Units: 12

System Details

Refrigerant Type: R-410A
 Holding Refrigerant Charge (lbs): 16.5
 Additional Charge (lbs/ft): install data
 Pre-charge Piping (Length ft): -
 Max. Pipe Length (Total ft):
 Max. Pipe Length (Vertical ft): 164 ft (295 ft) / 295 ft
 Max Height Separation (Ind to Ind ft):

Cooling Operation Range (°F): 23 - 110
 Cooling Range w/Baffle (°F):
 Heating Operation Range (°F): 0 - 77 / (-4) - 60
 Heating Range w/Baffle (°F):

Project Name: _____
 Location: _____
 Engineer: _____
 Submitted to: _____
 Submitted by: _____
 Reference: _____

Approval: _____
 Date: _____
 Construction: _____
 Unit #: _____
 Drawing #: _____

Dimensional Drawing - Condensing Unit

RXYQ72PBTJ

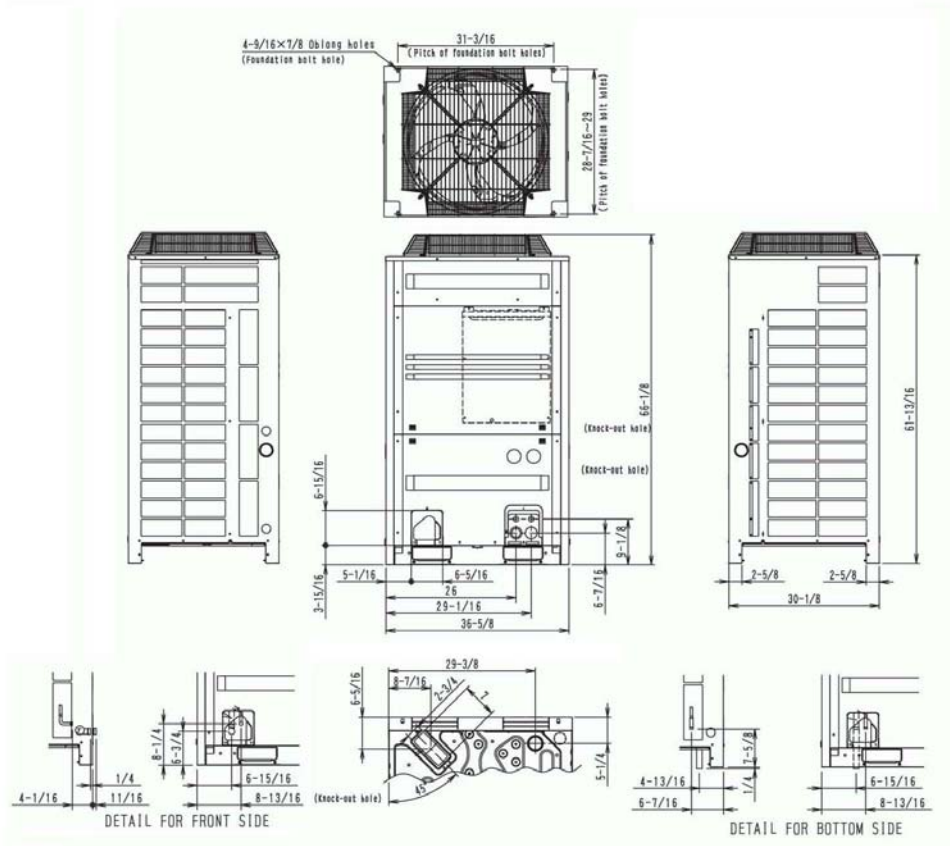

Submittal Data Sheet

Project Name: _____
Location: _____
Engineer: _____
Submitted to: _____
Submitted by: _____
Reference: _____

Approval: _____
Date: _____
Construction: _____
Unit #: _____
Drawing #: _____



RXYQ72PBTJ
Std U.S. Warranty: 7yrs Compressor, 1yrs Parts

Submittal Data Sheet

Project Name: Seaside Village
 Location: Portland, ME
 Engineer: Bennett Engineering
 Submitted to:
 Submitted by:
 Reference:

Approval:
 Date:
 Construction:
 Unit #:
 Drawing #:

Performance

Indoor Unit Model No: VAM470GVJU
 Rated Cooling Capacity (Btu/hr): N/A
 Sensible Capacity (Btu/hr): N/A
 Cooling Input Power (kW): 0.776
 Rated Heating Capacity (Btu/hr): N/A
 Heating Input Power (kW): 0.776

Indoor Unit Type: VAM
 Rated Cooling Conditions Ambient: 5 - 122 (80% RH) Indoor: N/A
 Rated Heating Conditions Ambient: 5 - 122 (80% RH) Indoor: N/A
 Rated Piping Length (ft): N/A
 Rated Height Separation (ft): N/A

Indoor Unit Details

Power Supply (V/Hz/Ph): 208-230/60/1ph
 Power Supply Connections: L1, L2, Ground
 Min. Circuit Amps MCA (A): 3.9
 Max. Overcurrent Protection (MOP) (A): 15
 Dimensions (HxWxD): 15-1/4x43-11/16x32-3/4
 Panel (HxWxD): N/A
 Net Weight (lbs): 121
 Net Weight with Panel (lbs): N/A

Airflow Rate (CFM wet coil) 470/470/390
 Moisture Removal (pt/h):
 Gas Pipe Connection (inch):
 Liquid Pipe Connection (inch):
 Condensate Connection (inch):
 Sound Pressure Level (dBA): 42
 Sound Power Level (dBA): 35
 External Static Pressure/Max (inWg): 0.33 - 0.73
 Controller Name:



VAM470GVJU
 Std U.S. Warranty: 6 year heat exchanger core,
 1yrs Parts

Project Name: _____
 Location: _____
 Engineer: _____
 Submitted to: _____
 Submitted by: _____
 Reference: _____

Approval: _____
 Date: _____
 Construction: _____
 Unit #: _____
 Drawing #: _____

Dimensional Drawing - Indoor Unit

VAM470GVJU

