



A Brand of Heatcraft Refrigeration Products
 2175 West Park Place Boulevard
 Stone Mountain, GA 30087
 800.537.7775
 www.larkinproducts.com

LHS040X6C
Hermetic
Air-cooled

Project:	QUOTATION: JG20120928153042;0 Item No: 1
Location: ,	Submitted by: John Gibson
Customer:	DATE: 9/28/2012
Identity #:	<input checked="" type="checkbox"/> For Record By: _____
Tag:	<input type="checkbox"/> For Approval Date: _____

PHYSICAL & ELECTRICAL DATA

REFRIGERANT	COMPRESSOR		CONNECTIONS (inches)		RECEIVER CAPACITY (90%)	NET WEIGHT	SOUND DATA	ALTITUDE	AMBIENT TEMP
	Model No.	HP	Liquid	Suction					
R404A/R507	CS27K6E	4	1/2	1 1/8	20	324	73	0	95°F

POWER SUPPLY	COMPRESSOR		FAN MOTOR			MCA†		MOP‡		Evap. Fan	Defrost Heater
	RLA	LRA	QTY	HP	FLA	Air	Elec.	Air	Elec.		
208-230/3/60	13.7	105	1	1/3	3.5	20.7		30			

†MCA=Minimum Circuit Ampacity
 ‡MOP= Maximum Overcurrent Protection

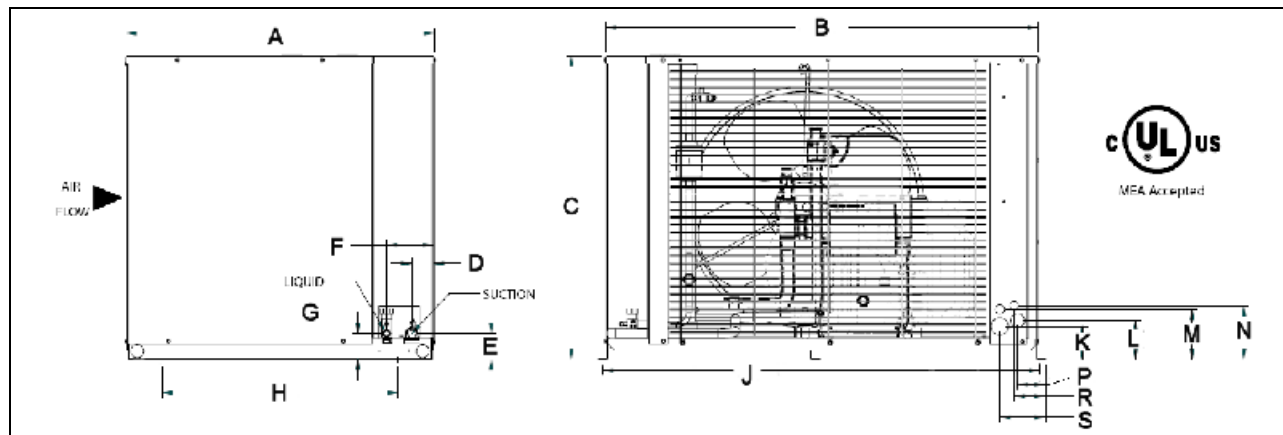

DIMENSIONS (inches)								
A	B	C	D	E	F	G	H	J
30 1/4	42 1/2	29 3/4	2 1/16	2 5/8	4 9/16	2 9/16	23 1/8	43

DIMENSIONS (inches)						
K	L	M	N	P	R	S



A Brand of Heatcraft Refrigeration Products
 2175 West Park Place Boulevard
 Stone Mountain, GA 30087
 800.537.7775
 www.larkinproducts.com

LHS040X6C
Hermetic
Air-cooled

Project:	QUOTATION: JG20120928153042;0 Item No: 1
Location: ,	Submitted by: John Gibson
Customer:	DATE: 9/28/2012
Identity #:	<input checked="" type="checkbox"/> For Record By: _____
Tag:	<input type="checkbox"/> For Approval Date: _____

3 1/4	3 13/16	4 15/16	5 1/4	1 15/16	2 1/4	3 11/16
-------	---------	---------	-------	---------	-------	---------

CAPACITY (BTUH)						
40 °F SST	35°F SST	30 °F SST	25 °F SST	20 °F SST	15 °F SST	10°F SST
49580	45670	41480	37270	33160	29720	26280

CAPACITY (BTUH)						
5 °F SST	0 °F SST	-5 °F SST	-10 °F SST	-15 °F SST	-20 °F SST	-25 °F SST
22840	19400	16770	14130	12650	11160	8200

CAPACITY (BTUH)						
-30 °F SST	-35 °F SST	-40 °F SST				
0	0	0				

SST = Saturated Suction Temperature

STANDARD FEATURES

- Cabinet & Construction
 - Painted steel cabinets with outdoor weather hood
 - Heavy duty steel raised base with 1-1/2" legs
 - Suction service valves for hermetic and scroll compressors located outside the cabinet
 - Semi-hermetic compressor models have a suction valve on the compressor and an access fitting on the suction line entering the cabinet
 - Receiver with fusible plug, liquid shutoff valve and charging port
 - Large electrical panel
 - Prefabricated wiring harnesses
 - Sight glass/moisture indicator
 - Piping is pre-bent to eliminate leaks
 - Head pressure control valve
 - Ambient temperature sensor
- Coil:
 - HyperCore™ microchannel coil technology
 - Completely leak tested in a helium environment
- Compressor
 - Hermetic, semi-hermetic and scroll. R-22 and R-404A/507 available for both medium and low temperature applications
 - Spring-mounted compressors with vibration eliminators on all 1-1/2 to 6 HP semi-hermetic compressors; 1/2 to 1 HP compressors are rigid mounted and have a discharge loop
 - Discharge service valves
 - Crankcase Heater
 - 24 volt compressor control circuit
 - Service switch
 - Bump tested and allowed to cycle off on the high and low pressure control
 - Encapsulated, auto-reset, high and low pressure controls (adjustable low pressure control on low temperature models)
- Fan Motors:
 - Rated for 50 and 60 cycle application
 - Standard PSC fan motors
 - Specifically matched fans with motor and coil
 - Fan Cycling (on 2 fan units)



A Brand of Heatcraft Refrigeration Products
 2175 West Park Place Boulevard
 Stone Mountain, GA 30087
 800.537.7775
 www.larkinproducts.com

LHS040X6C
 Hermetic
 Air-cooled

Project:	QUOTATION: JG20120928153042;0 Item No: 1
Location: ,	Submitted by: John Gibson
Customer:	DATE: 9/28/2012
Identity #:	<input checked="" type="checkbox"/> For Record By: _____
Tag:	<input type="checkbox"/> For Approval Date: _____

OPTIONS

Mounted Options:

<input checked="" type="checkbox"/> Liquid Filter Drier: Liquid Drier and Sight Glass	<input checked="" type="checkbox"/> Misc:Suction Accumulator
---	--

Ship Loose Options:

None	
------	--

MINIMUM UNIT CLEARANCES

Walls or Obstructions for Horizontal Air Flow

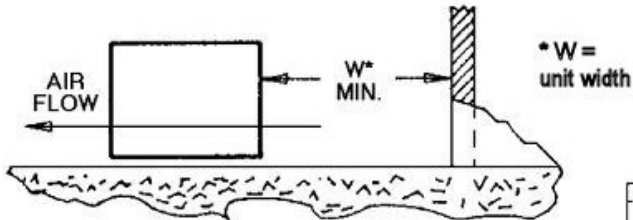

Multiple Units with Horizontal Air Flow

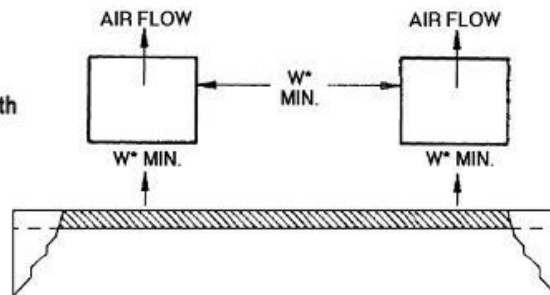



A Brand of Heatcraft Refrigeration Products
 2175 West Park Place Boulevard
 Stone Mountain, GA 30087
 800.537.7775
 www.larkinproducts.com

LCA6160BB
 Low Profile
 Walk-in

Project:	QUOTATION: JG20120928153042;0 Item No: 1
Location: ,	Submitted by: John Gibson
Customer:	DATE: 9/28/2012
Identity #:	<input checked="" type="checkbox"/> For Record By: _____
Tag:	<input type="checkbox"/> For Approval Date: _____

PHYSICAL & ELECTRICAL DATA

DEFROST TYPE	AIR FLOW	VOLTAGE	CAPACITY	RATING TD	RATING SST	Approx. NET WEIGHT	ALTITUDE
Air	1950	208-230/1/60	16000	10	23	67	0

FANS				HEATERS		CONNECTIONS (inches)		
QTY	FLA	MOTOR TYPE	BLADE	AMPS	WATTS	INLET	OUTLET	DRAIN
3	1.5	EC	12.0			1/2	7/8	3/4

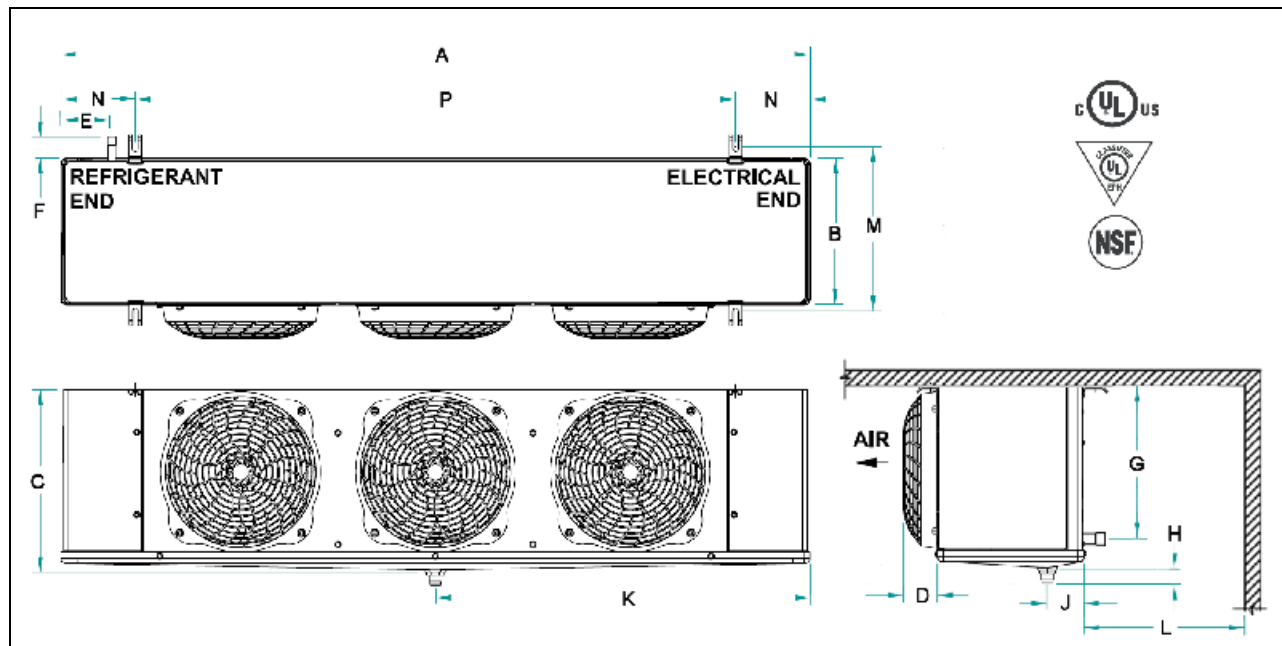

DIMENSIONS (inches)											
A	B	C	D	E	F	G	H	J	K	L	M
61.50	12.00	14.94	2.88	4.19	1.75	12.38	1.06	3.00	30.75	18.00	13.44

DIMENSIONS (inches)								
N	P	R	S	T	U	V	X	Y
6.13	49.25	0.00	0.00	0.00	0.00	0.00	0.00	0.00



A Brand of Heatcraft Refrigeration Products
 2175 West Park Place Boulevard
 Stone Mountain, GA 30087
 800.537.7775
 www.larkinproducts.com

LCA6160BB
Low Profile
Walk-in

Project:	QUOTATION: JG20120928153042;0 Item No: 1
Location: ,	Submitted by: John Gibson
Customer:	DATE: 9/28/2012
Identity #:	<input checked="" type="checkbox"/> For Record By: _____
Tag:	<input type="checkbox"/> For Approval Date: _____

STANDARD FEATURES

- Cabinet
- Attractive white painted aluminum cabinet
 - Front Access to electrical and refrigeration components
 - Small, low profile physical cabinet size with optimized interior space
 - The electrical board is front facing for easy access
 - Internal panels are isolated for quiet operation
 - Beacon II™ microprocessor mounted in piping section
 - Thermistor temperature sensors factory mounted
- (suction line, coil end plate, and entering air stream)
- Refrigerant distributor nozzle is factory mounted
 - Electric expansion valve factory mounted
 - Suction pressure transducer factory mounted
 - 24V control circuit transformer factory mounted
- Drain Pan:
- Drain fitting is located to the back of the unit with larger diameter

- Coil:
- Internally enhanced copper tubing and aluminum fin design for higher efficiency
 - Schrader valve on suction header
 - Sweat connections to reduce potential for leaks
- Fan Guards and Motors:
- Improved plastic, round guard design
 - Motor harness and solenoid harness are at the bottom of the unit for easy access
 - Motor harness easily plugs in
 - EC motors available factory-installed

OPTIONS

Mounted Options:

<input checked="" type="checkbox"/> Motor: EC	
---	--

Ship Loose Options (by Unit):

None	
------	--

Ship Loose Options (by System):

None	
------	--

MINIMUM UNIT CLEARANCES



A Brand of Heatcraft Refrigeration Products
 2175 West Park Place Boulevard
 Stone Mountain, GA 30087
 800.537.7775
 www.larkinproducts.com

LCA6160BB
 Low Profile
 Walk-in

Project:	QUOTATION: JG20120928153042;0 Item No: 1
Location: ,	Submitted by: John Gibson
Customer:	DATE: 9/28/2012
Identity #:	<input checked="" type="checkbox"/> For Record By: _____
Tag:	<input type="checkbox"/> For Approval Date: _____

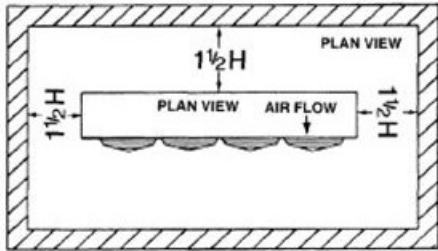

One evaporator

NOTE:
 H = Total height
 evaporator
 coil surface.

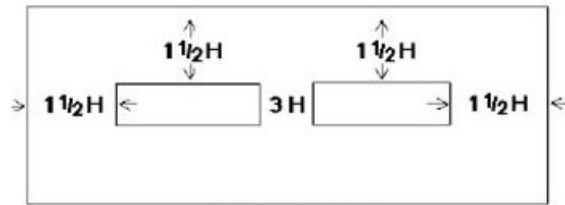

Two evaporators