

Larkin Refrigeration Products

2175 West Park Place Blvd.
Stone Mountain, GA 30087 • (770) 465-5600

SUBMITTAL DRAWINGS

Model ACM (Air Defrost)

UNIT COOLERS

Project: _____	Location: _____	Date: _____
Arch/Engr: _____		by: _____
Customer: _____	Order No. _____	<input type="checkbox"/> for approval
Identity: _____ Item No. _____	Model No. _____ Qty: _____	<input type="checkbox"/> for record

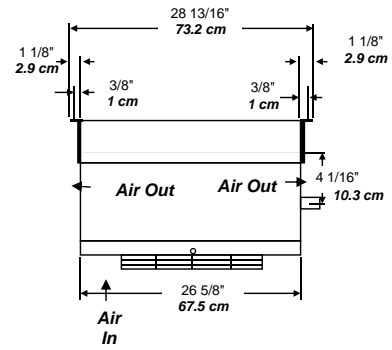
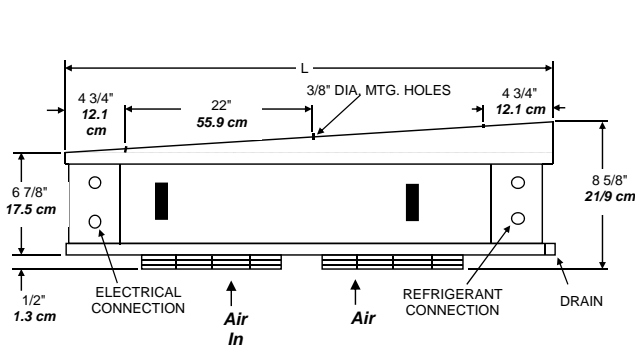

SPECIFICATION DATA

ACM Model No.	Dimensions			Net Weight (Lbs.)/kg.
	L In/cm	Inlet OD In.	Suction OD In.	
052	31 1/2/80	1/2	7/8	42/19
076	53 1/2/136	1/2	7/8	64/29
090	53 1/2/136	1/2	7/8	70/32
102	53 1/2/136	1/2	7/8	83/38
108	75 1/2/192	1/2	7/8	105/48
134	75 1/2/192	1/2	7/8	117/53
156	75 1/2/192	1/2	7/8	123/56
179	97 1/2/248	1/2	1-1/8	149/68
208	97 1/2/248	1/2	1-1/8	164/74
249	119 1/2/304	1/2	1-1/8	206/94

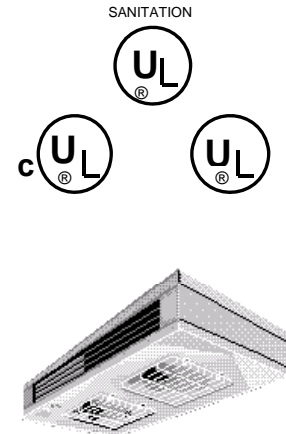

ACM Model No.	Capacities BTUH/kcal/h				Fans			Electrical Amps			
	60 Hz.		50 Hz.		No.	60 Hz.	50 Hz.	*60 Hz.		†50 Hz.	
	10° F TD	15° F TD	6° K	8° K		CFM/m³h	CFM/m³h	115 Volts	230 Volts	110 Volts	220 Volts
052	5200/1310	7800/1965	5300/1335	7125/1795	1	610/1035	550/935	2.1	1.1	0.8	0.4
076	7600/1915	11400/2872	7760/1955	10400/2620	2	1300/2210	1170/1990	4.2	2.2	1.7	0.8
090	9000/2268	13500/3402	9190/2315	12325/3105	2	1260/2140	1135/1930	4.2	2.2	1.7	0.8
102	10200/2570	15300/3855	10400/2620	13975/3520	2	1220/2075	1100/1865	4.2	2.2	1.7	0.8
108	10800/2721	16200/4082	11015/2775	14790/3725	3	1950/3315	1755/2985	6.3	3.3	2.5	1.2
134	13400/3376	20100/5065	13655/3440	18340/4620	3	1890/3210	1700/2890	6.3	3.3	2.58	1.2
156	15600/3931	23400/5896	15920/4010	23155/5380	3	1830/3110	1650/2800	6.3	3.3	2.5	1.2
179	17900/4510	26850/6766	18260/4600	24515/6175	4	2520/4285	2270/3855	8.4	4.4	3.3	1.6
208	20800/5241	31200/7862	21220/5345	28485/7175	4	2440/4145	2200/3735	8.4	4.4	3.3	1.6
249	24900/6274	37350/9412	25410/6400	34100/8590	5	3050/5185	2745/4665	10.5	5.5	4.2	2.0

All units have 1/4" OD external equalizer and 3/4" F.P.T. drain connection.

* 60Hz. units have shaded pole motors.

† 50Hz. units have PSC motors.

©Heatcraft Inc. 1996

Panel LCMA52396