



# PENSOTTI

A GRANBY COMPANY

## *Instruction Manual*

### **PCH 34/B**

**Condensing Combination  
Space heating / Water heater  
116,008 BTU/h INPUT**



#### **WARNING**

If the information in these instructions is not followed exactly, a fire or explosion may result, causing property damage, personal injury or death.

- Do not store or use gasoline or other flammable vapors or liquids in the vicinity of this or any other appliance.
- WHAT TO DO IF YOU SMELL GAS
  - Do not try to light any appliance
  - Do not touch any electrical switch; do not use any phone in your building
  - Immediately call your gas supplier from a neighbor's phone. Follow the gas supplier's instructions.
  - If you cannot reach your gas supplier, call the fire department
- Installation and service be performed by a qualified installer, service agency or the gas supplier.
- Use of a properly calibrated electronic combustion analyzer **MUST** be used to install and/or service this appliance.

Approved in accordance with:  
ANSI Z21.10 / CSA 4.3 - 2011



	<i>Pages</i>
<b>1. General information</b>	
1.1 General warnings	1
1.2 Product conformity	9
<b>2. Technical characteristics</b>	
2.1 Technical data	10
2.2 Dimensions	11
2.3 Internal parts of the water heater	12
2.4 Water circuit	13
2.5 Circulation pump head/flow graph	14
2.6 Printed circuit board – Technical characteristics	15
2.7 Control panel	15
<b>3. Installation (authorized personnel)</b>	
3.1 Reference standard	16
3.2 Unpacking	17
3.3 Installation water heater	18
3.4 Water connections	19
3.5 Domestic Hot Water Circuit / Hard Water Warning / Expansion Tank	20
3.6 Piping Diagram	21
3.7 Condensate Drain	22
3.8 Gas connection	23
3.9 Electrical connections	25
3.10 Venting connections	28
<b>4. Commissioning the appliance (authorized personnel)</b>	
4.1 General warnings	33
4.2 Filling the system	34
4.3 Flushing the system	35
4.4 Filling the condensate trap	35
4.5 Starting up the water heater	36
<b>5. Regulating the appliance (authorized personnel)</b>	
5.1 Parameters table	37
5.2 Setting the parameters	38
5.3 Gas Data	45
5.4 Converting the Water Heater to a Different Gas Type	46

	<i>Pages</i>
<b>6. Maintenance (authorized personnel)</b>	
6.1 General warnings	48
6.2 Maintenance	48
6.3 Water heater inspection	49
6.4 Accessing the water heater	50
6.5 Flushing out the primary side	50
6.6 Draining the central heating and domestic hot water system	51
6.7 Maintenance operations	52
6.8 Wiring diagrams	58
6.9 Troubleshooting	61
6.10 Diagnostics	62
6.11 Parts list	63
6.12 Cycle Sequence Flow Chart	64

# 1. GENERAL INFORMATION

## 1.1 General warnings – Installation

Read all safety warnings in the "Instruction Manual". The additional safety issues outlined below must also be followed completely when installing this Combination Water heater.

Use of a properly calibrated electronic combustion analyzer **MUST** be used when installing, servicing or converting this Combination Water heater from Natural Gas to LP or from LP to Natural Gas.

Failure to remove or maintain the area free of combustible material, gasoline and other flammable liquids or vapors can result in severe personal injury, death or substantial property damage.

All applicable local, state, national and provincial codes, ordinances, regulations and laws must be observed.

For installations in Massachusetts – code requires the units to be installed by a licensed plumbing or gas fitter.

The appliance cannot operate without the correct amount of air for combustion. Please make sure there is sufficient inflow and outflow of air for ventilation, never obstruct the flow of ventilation air. Failure to provide the proper amount of combustion air can result in a fire or explosion and cause death, serious bodily injury or property damage.

If an external electrical source is utilized, the appliance, when installed, must be electrically grounded in accordance with local codes or, in the absence of local codes, with the National Electrical Codes ANSI/NFPA 70 and or the CSA C22.1 Canadian Electrical Code.

**Follow all local codes and/or the most recent edition of the National Fuel Gas Code (ANSI Z223.1/NFPA 54) in the USA or the Natural Gas and Propane Installation Code in Canada (CAN/CSA B149.1).**

This unit is designed for indoor installations. **DO NOT** operate this unit without the vent piping connected. Exhaust gases must be completely expelled out of the building.

**Do not use this appliance if any part has been underwater. Immediately call a qualified service technician to inspect the appliance and replace any part of the control system and any gas control which has been underwater.**

Be sure not to reverse the water and gas connections as this may damage the gas valves.

**Water temperatures over 125°F can cause severe burns instantly or death from scalding. If the proposed water heater outlet temperature is above 125°F, a thermostatically controlled mixing valve (or a temperature limiting valve) for reducing point of use water temperature is recommended to reduce the risk of scald injury. Contact a licensed plumber or the local plumbing authority for further information.**

**The appliance should be located in an area where leakage within the unit or at its connections will not result in damage to the area adjacent to the appliance or to lower floors of the structure. PENSOTTI will not be responsible for any damage resulting from leaking if adequate drainage is not provided. When such locations cannot be avoided, it is recommended that a suitable drain pan, adequately drained, be installed under the appliance.**

Do not use this combination water heater for any purpose other than water heating and space heating.

The flow of combustion air and ventilation to the water heater must not be obstructed. The water heater area must be kept clear and free from combustible materials, gasoline and other flammable vapors and liquids.

If the water quality is known to be highly acidic and/or extremely hard, water treatments (ie water softeners and filtration) are recommended to maintain full warranty. Consult the local water authority.

**DO NOT** over-tighten fittings, as pipe and/or fitting damage may occur causing leakage.

**DO NOT** install water heater where subject to vibrations.

For other than a direct vent appliance, the appliance must be located as close as possible to a chimney or gas vent.

**Should overheating occur or the gas supply fails to shut off, turn the manual gas control valve to the appliance. Contact a Service Technician immediately.**

Clearance must be in accordance with the local installation codes and the requirements of the gas supplier.

Never operate the heater unless it is vented to the outdoors and has adequate air supply to avoid risks of improper operation, fire, explosion or asphyxiation.

**DO NOT install this water heater directly on a carpeted floor. A fire hazard may result. The water heater shall be installed on a metal or wood panel extending beyond the full width and depth of the water heater by at least 3 inches (76.2mm) in any direction or, if the water heater is installed in an alcove or closet, the entire floor shall be covered by the panel.**

**For safe operation, an ample supply of air must be provided for proper combustion and ventilation in accordance with the National Fuel Gas Code ANSI Z223.1/NFPA 54 National Fuel Gas Code CSA/B149.1 Natural Gas and Propane Installation Codes or applicable provisions of the local building codes. An insufficient supply of air may result in a yellow, luminous burner flame, carboning or sooting of the heat exchanger, or create a risk of asphyxiation. Do not obstruct the flow of combustion and ventilation air.**

This unit is not intended to operate at gas supply pressures other than those shown on the rating plate. Exposure to higher gas supply pressure may cause damage to gas valves, which can result in fire or explosion. If over-pressure has occurred, such as through improper testing of gas lines or emergency malfunction of the supply system, the gas valves must be checked for safe operation.

**A thermostatic mixing valve must be added to this system to prevent scalding, if regulated by local codes and authorities.**

### Check the Rating Plate

PENSOTTI units come from the factory configured for use with natural gas. Prior to installation, check the rating plate of the water heater to ensure the unit matches gas type, gas pressure, water pressure and electrical supply. If the unit does not match the requirements, do not install.

Be sure the gas type and electricity voltage match the rating plate.

There is a risk in using fuel burning appliances in rooms or areas where gasoline, other flammable liquids or engine-driven equipment or vehicles are stored, operated or are repaired. Flammable vapors are heavy and travel along the floor and may be ignited by the igniter or main burner flames causing fire or explosion. Some local codes permit operation of gas appliances if installed 18 inches or more above the floor. This may reduce the risk if location in such an area cannot be avoided. Flammable items, pressurized containers or any other potential fire hazardous articles must never be placed on or adjacent to the water heater. Open containers of flammable materials should not be stored or used in the same room with the water heater.

Do not install the PENSOTTI water heater in areas with excessive high humidity.

Do not install the unit in location where there is excessive humidity, such as a bathroom, damp crawl space, and other areas with high levels of humidity. This may cause the unit to malfunction.

To avoid possible electrical shock, DO NOT touch the internal components of the water heater or the power cord with wet hands.

DO NOT splash excessive water on the water heater when cleaning, as they are water resistant, not water proof.

Professionally qualified personnel in accordance with current laws and standards and in line with the manufacturer's instructions must install the appliance.

The commissioning of the water heater and any subsequent works carried out on the appliance must be effected by an appropriately qualified technician.

The appliance must be used solely for the purpose for which it has been designed and manufactured: central heating and domestic hot water production. Any other use is deemed as improper and as such dangerous. Under no circumstances will the manufacturer be held responsible for damage or injury to persons or animals caused by errors in the installation and/or use of the appliance, or through non-compliance with current local and national standards and/or the manufacturer's instructions.

The installation, operation and maintenance manual forms are an integral and essential part of the product and must be kept with the appliance always.

The warnings contained in this chapter have been written for the appliance user, the installer and the service technician.

The "operating instructions" chapter of this manual must be read carefully as it provides information on the operation and the operating limits of the appliance.

After the removal of all the packaging, check that the appliance has not been damaged. In case of doubt, do not attempt to use the product but refer to the supplier. Packing materials (cardboard box, wooden crate, nails, staples, plastic bags, polystyrene, etc.) must not be left within reach of children in that these items represent a potential hazard and must be disposed of in a responsible manner.

Before carrying out any cleaning or maintenance operations, disconnect the appliance from the mains electricity supply by switching off at the main switch and/or any other isolating device.

In the case of a fault and/or malfunction in the appliance, shut down the system. Do not interfere with or attempt any repairs. Call for professionally qualified technical assistance only.

Any warranty repairs to the appliance must be carried out exclusively by the manufacturer's authorized service dealers using original spare parts. Non-compliance with the above requirements may compromise the safety of the appliance and invalidate the warranty. In order to guarantee the efficiency of the appliance and its correct operation, it must be serviced regularly by professionally qualified personnel in line with the manufacturer's instructions.

Only original accessories or optional extras (including electrical parts) must be used with the appliance.

Should there be a smell of gas present in the room where the appliance is installed, **DO NOT** attempt to activate any electric switches, telephones or any other equipment that may cause sparks. Open doors and windows immediately to create a current of air and ventilate the room. Shut-off the main gas supply valve (at the meter), or on the cylinder in the case of bottled gas, and call an authorized service center.

**Do not attempt to interfere with the appliance in any way.**

As dictated by current legislation, this appliance **must be installed exclusively by qualified personnel**. Before starting the water heater for the first time, make sure that it is connected to a water supply and central heating system compatible with its performance characteristics.

Prior to start-up, the central heating pipes should be flushed to remove any residues that could compromise the operation of the appliance.

The appliance must be connected to a designated electrical circuit only.

The power supply must be checked by a qualified electrician to ensure that it can support the maximum power absorption of the appliance, as indicated on the appliance rating plate (positioned on the casing). In particular, make sure that the cable ratings are adequate for the power absorbed.

Do not use adapters; multiple sockets or extension leads to connect the appliance to the power supply.

The appliance must be connected to the mains power supply through an appropriate electrical isolator in accordance with the current wiring regulations.

If the cable is damaged in any way, switch off the appliance and have the cable replaced by a suitably qualified technician.

**When the appliance is no longer required for use, switch off the main power supply, to switch all electrical components off (circulating pump, burner etc.).**

**The thermostats are adjusted at their minimum lowest temperature positions when shipped from the factory.**

**Caution: Label all wires prior to disconnection when servicing controls. Wiring errors can cause improper and dangerous operation.**

**Important: Carbon Monoxide Detectors**



Many jurisdictions require the installation of carbon monoxide detectors in building where a side wall vented fuel burning appliance is installed. Installers must abide by local code requirements regarding the installation of CO detectors. The use of a certified carbon monoxide detector is recommended but not required by PENSOTTI.

**"In the State of Massachusetts only"**

(a) For all horizontally vented gas fuelled equipment installed in every dwelling, building or structure used in whole or in part for residential purposes, including those owned and operated by the Commonwealth and where the side wall exhaust vent termination is less than seven (7) feet above finished grade in the area of the venting, including but not limited to decks and porches, the following requirements shall be satisfied:

1. **INSTALLATION OF CARBON MONOXIDE DETECTORS.** At the time of installation of the side wall horizontal vented gas fuelled equipment, the installing plumber or gas fitter shall observe that a hard wired carbon monoxide detector with an alarm and battery back-up is installed on the floor level where the gas equipment is to be installed and on each additional level of the dwelling, building or structure served by the equipment. It shall be the responsibility of the property owner to secure the services of qualified licensed professionals for the installation of hard wired carbon monoxide detectors.
  - a. In the event that the side wall horizontally vented gas fuelled equipment is installed in a crawl space or an attic, the hard wired carbon monoxide detector with alarm and battery back-up may be installed on the next adjacent floor level.
  - b. In the event that the requirements of this subdivision cannot be met at the time of completion of installation, the owner shall have a period of 30 days to comply with the above requirements; provided, however, that during said 30 day period a battery operated carbon monoxide detector with alarm shall be installed.
2. **APPROVED CARBON MONOXIDE DETECTORS.** Each carbon monoxide detector as required in accordance with the above provisions shall comply with NFPA 720 and be ANSI/UL 2034 listed and IAS certified.
3. **SIGNAGE.** A metal or plastic identification plate shall be permanently mounted to the exterior of the building at a minimum height of eight (8) feet above grade directly in line with the exhaust vent terminal for the horizontally vented gas fuelled heating appliance or equipment. The sign shall read, in print size no less than one-half (1/2) inch in size, "**GAS VENT DIRECTLY BELOW. KEEP CLEAR OF ALL OBSTRUCTIONS**".
4. **INSPECTION.** The state or local gas inspector of the side wall horizontally vented gas fuelled equipment shall not approve the installation unless, upon inspection, the inspector observes carbon monoxide detectors and signage installed in accordance with the provisions of 248 CMR 5.08(2)(a) 1 through 4.

GENERAL INFORMATION

**FOR YOUR SAFETY READ BEFORE OPERATING**

**WARNING:** If you do not follow these instructions exactly, a fire or explosion may result causing property damage, personal injury or loss of life.

**A.** This appliance does not have a pilot. It is equipped with a direct ignition device, which automatically lights the burner. Do not try to light the burner by hand.

**B. BEFORE OPERATING:** Smell all around the appliance area for gas. Be sure to smell next to the floor because some gas is heavier than air and will settle on the floor.

**WHAT TO DO IF YOU SMELL GAS**

- Do not try to light any appliance.
- Do not touch any electric switch; do not use any phone in your building.

**C.** Use only your hand to operate the remote control keypad. Never use tools. If the remote keypad doesn't work, do not try to repair it, call a qualified service technician. Forced or improper repair may result in a fire or explosion.

**D.** Do not use this appliance if any part has been under water. Immediately call a qualified service technician to inspect the appliance and to replace any part of the control system and any gas control which has been under water.

- Immediately call your gas supplier from a neighbor's phone. Follow the gas supplier's instructions.
- If you cannot reach your gas supplier, call the fire department.

**OPERATING INSTRUCTIONS**

1. **STOP!** Read the safety information above before proceeding.
2. Set the thermostat to the lowest setting.
3. Turn off all power to the electrical appliance.
4. This appliance does not have a pilot. It is equipped with a direct ignition device, which automatically lights the burner. Do not try to light the burner by hand.
5. Turn the manual valve located at the gas inlet of the appliance clockwise  to "OFF"

6. Wait (5) minutes to clear out any gas. If you then smell gas, **STOP!** Follow "B" in the safety information above on this label. If you don't smell gas, go to next step.
7. Turn the manual valve located at the gas inlet of appliance counterclockwise to  "ON" (see Figure 47).
8. Turn on all electric power to the appliance.
9. Set the thermostat to desired setting.
10. If the appliance will not operate, follow the instructions "To Turn Off Gas To Appliance" and call your service technician or gas supplier.

**TO TURN OFF GAS TO THE APPLIANCE**

1. Set the thermostat to the lowest setting.
2. Turn off all electric power to the appliance if service is to be performed.

3. Turn the manual valve at gas inlet of appliance clockwise  to "OFF" (see figure 47).

**Manual Gas Valve**

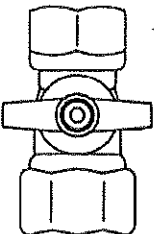

← CLOSED MANUAL VALVE ('OFF' POSITION)

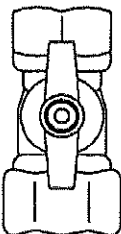

→ OPEN MANUAL VALVE ('ON' POSITION)



GENERAL INFORMATION

 **WARNING**

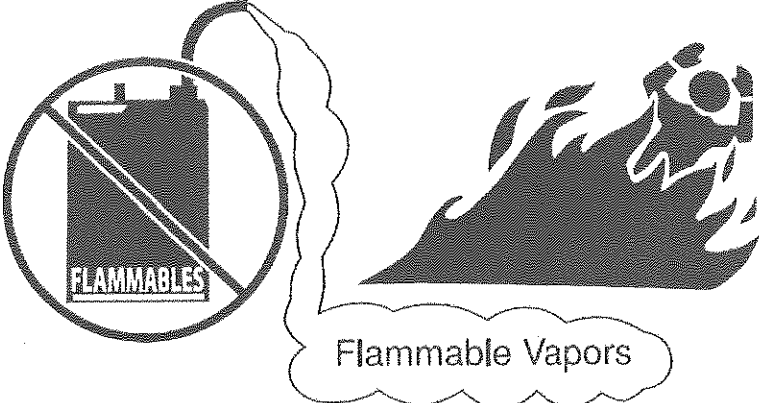

Flammable Vapors

**FIRE AND EXPLOSION HAZARD**  
Can result in serious injury or death

 Do not store or use gasoline or other flammable vapors and liquids in the vicinity of this or any other appliance. Storage of or use of gasoline or other flammable vapors or liquids in the vicinity of this or any other appliance can result in serious injury or death.

<p>Vapors from flammable liquids can explode and catch fire causing death or severe burns.</p> <p><b>Keep flammable products:</b></p> <ol style="list-style-type: none"><li>1. far from any possible ignition source,</li><li>2. in approved containers</li><li>3. tightly closed and</li><li>4. out of children's reach</li></ol>	<p>Do not use or store flammable products such as gasoline, solvents or adhesives in the same room or area near this appliance, or any other appliance or any possible ignition source.</p> <p><b>Vapors:</b></p> <ol style="list-style-type: none"><li>1. cannot be seen,</li><li>2. are heavier than air</li><li>3. go a long way on the floor</li><li>4. can be carried away from other rooms to possible ignition sources by air currents</li></ol>
--	---

Water heaters in residential garages must be installed and located, or protected, to avoid physical damage.

Read and follow water heater warnings and instructions. If owner's manual is missing contact the distributor or manufacturer.

GENERAL INFORMATION

**! DANGER**

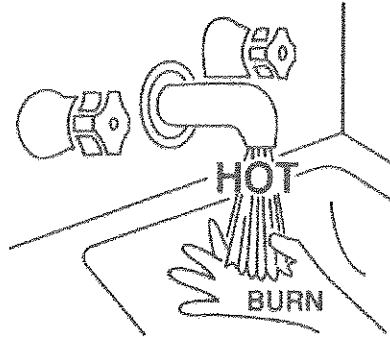

The temperature at which injury occurs varies with the person's age and time of exposure.

The slower response time of disabled persons increases the hazards to them. Never allow small children to use a hot water tap, or to draw their own bath water. Never leave a child or disabled person unattended in a bathtub or shower.

The water heater should be located in an area where the general public does not have access to the temperature control.

Lower water temperatures should be used to avoid the risk of scalding. It is further recommended, in all cases, that the water temperature be set for the lowest temperature which satisfies the user's hot water needs. This will also provide the most energy efficient operation of the water heater and minimize scale formation in the heat exchanger, thus prolonging the life of the unit.

Setting the water heater temperature at 120°F will reduce the risk of scalds. Some states require settings at specific lower temperatures. The table below shows the approximate time-to-burn relationship for normal adult skin.

Hot water temperatures required for automatic dishwasher and laundry use can cause scalds and burns resulting in serious personal injury and/or death.

Table - Risk of Scalds

Temperature Setting	Time to Produce, 2nd, 3rd Degree Burns on Adult Skin
Over 170 °F	Nearly instantaneous
160 °F	About 1/2 second
150 °F	About 1-1/2 seconds
140 °F	Less than 5 seconds
130 °F	About 30 seconds
120 °F or less	More than 5 minutes

To protect against injury, you should install a tempering valve in the water system. This valve will reduce point of discharge temperature by mixing cold and hot water in branch supply lines. Such valves are available from the local plumbing supplier.

## WARNING

If the information in these instructions is not followed exactly, a fire or explosion may result, causing property damage, personal injury or death.

-Do not store or use gasoline or other flammable vapours and liquids in the vicinity of this or any other appliance.

-WHAT TO DO IF YOU SMELL GAS

- Do not try to light any appliance.
- Do not touch any electrical switch; do not use any phone in your building.
- Immediately call your gas supplier from a neighbour's phone. Follow the gas supplier's instructions.
- If you cannot reach your gas supplier, call the fire department.

-Installation and service must be performed by a qualified installer, service agency or the gas supplier.

Minimum clearances from combustible construction, 0-inches sides, 0-inches back, 0-inches top.

For closet installation, 0-inches front, or for alcove installation.

This water heater is provided with a pressure relief valve. For safe operation of the water heater, the relief valve(s) must not be removed from its designated point of installation or unplugged.

The temperature and pressure relief valve provided by the manufacturer shall be installed at the time of installation of the heater in the location specified by the manufacturer. Local codes shall govern installation of relief devices. For safe operation of the water heater, the relief valve must not be removed or unplugged.

### "Warning"

"This appliance must be installed in accordance with the local codes or, in the absence of local codes, the National Fuel Gas Code, ANSI Z223.1/NFPA 54 or the CSA B149.1, Natural Gas and Propane Installation Code".

### SUITABLE FOR WATER (POTABLE) HEATING AND SPACE HEATING

Toxic chemicals, such as used for boiler treatment, shall not be introduced into potable water heater used for space heating. This water heater may never be connected to any existing heating system or component(s) previously used with a non potable water heating appliance.

"For operation at outlet water temperatures not in excess of 180°F (88°C)"

## 1.2 Product conformity

All Pensotti LLC water heaters are ETL certified and possess technical and functional characteristics that comply with the following standards:

Gas fired water heaters also comply with the following standards:

American National Standard/CSA Standard for Gas Water Heaters Volume III, Storage Water Heaters with input Ratings above 75,000 Btu per Hour, Circulating and Instantaneous. Conforms to ANSI STD Z21.10.3, certified to CSA STD 4.3.

The materials used such as copper, brass, stainless steel, etc. form a compact, uniform, highly functional unit that is easy to install and simple to operate. In its simplicity, the wall-mounted appliance is equipped with all the appropriate accessories required to make it a fully independent water heater capable of satisfying domestic hot water production and central heating needs. All water heaters are fully inspected and are accompanied by a quality certificate, signed by the inspector, and a guarantee certificate. This manual must be kept in a safe place and must **accompany the water heater at all times.**

**Pensotti LLC will not be held responsible for any misinterpretation of this manual resulting from the inaccurate translation of same.**

**Pensotti LLC will not be held responsible for the consequences in the case of non-observance of the instructions contained in this manual or in the case where actions not specifically described herein are undertaken.**

## 2. TECHNICAL CHARACTERISTICS

### 2.1 Technical data

Model		PCH 34/B
CE Certification	n°	0694BN3485
Appliance Type		B23p-B33-C13-C33-C43-C53-C63-C83-C93
Appliance Category		II2H3B/P
Heat Input max	kW - BTU/hr	34 - 116013
Heat Input min	kW - BTU/hr	10 - 34121
Heat Output max - 122/86°F	kW - BTU/hr	36.2 - 123670
Heat Output max - 176/140°F	kW - BTU/hr	33.4 - 114041
Heat Output min - 176/140°F	kW - BTU/hr	9.7 - 33200
Efficiency 100% (full load 122/86°F)	%	95
Efficiency 30% (partial load 122/86°F)	%	97.5
Efficiency 100% (full load 176/140°F)	%	87.7
Efficiency 30% (partial load 176/140°F)	%	88.9
GAS DIRECTIVE 92/42/ECC - Efficiency marking	stars	4
Sedbuk	band	A
<b>Central Heating circuit</b>		
Central Heating water temperature setting (min-max)	°C – °F	30-80 / 25-40 – 86-176 / 77-104
Max. heating working temperature	°C – °F	80 – 176
Expansion vessel capacity	gal	1.85
Max. working pressure (heating)	bar - psi	2.1 - 30
Min. working pressure (heating)	bar - psi	0.3 - 4.29
<b>Domestic Hot Water circuit</b>		
D.H.W. temperature setting (min-max)	°C – °F	35-70 – 95-160
Max. Hot water working pressure	bar - psi	6 – 86
Min. Hot water working pressure	bar - psi	0.5 - 7.16
<b>Dimensions (Boiler casing size)</b>		
Width	in	16.1
Height	in	28.7
Depth	in	12.2
Weight (net)	lb	88
<b>Hydraulic connections</b>		
Central Heating Flow connection	NPT	3/4"
Central heating Return connection	NPT	3/4"
Central heating flow connection to DHW storage cylinder	NPT	3/4"
Central heating return connection from DHW storage cylinder	NPT	3/4"
Cold water mains connection	NPT	1/2"
Gas connection	NPT	1/2"
<b>Flue systems</b>		
Horizontal-Concentric flue system	Ø mm - in	80/125 - 3.15/5
Max. Flue length	m - ft	8 - 26
<b>Gas Supply</b>		
<b>Natural gas G 20</b>		
Inlet pressure	mbar - psi	20 - 0.29
Gas consumption	m <sup>3</sup> /h - ft <sup>3</sup> /h	3.60 – 127.13
<b>Propane G31</b>		
Inlet pressure	mbar - psi	37 - 0.53
Gas consumption	m <sup>3</sup> /h - ft <sup>3</sup> /h	1.38 – 48.73
<b>Electrical specifications</b>		
Power supply	V/Hz	110/60
Electrical power consumption	W	180
Electrical protection	IP	X4D

## 2.2 Dimensions

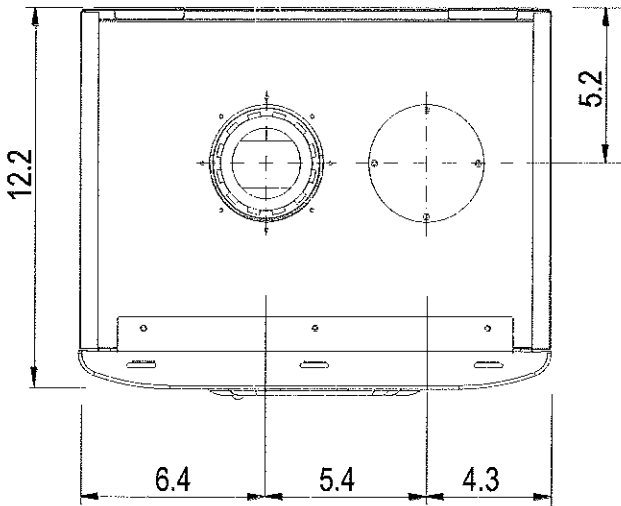
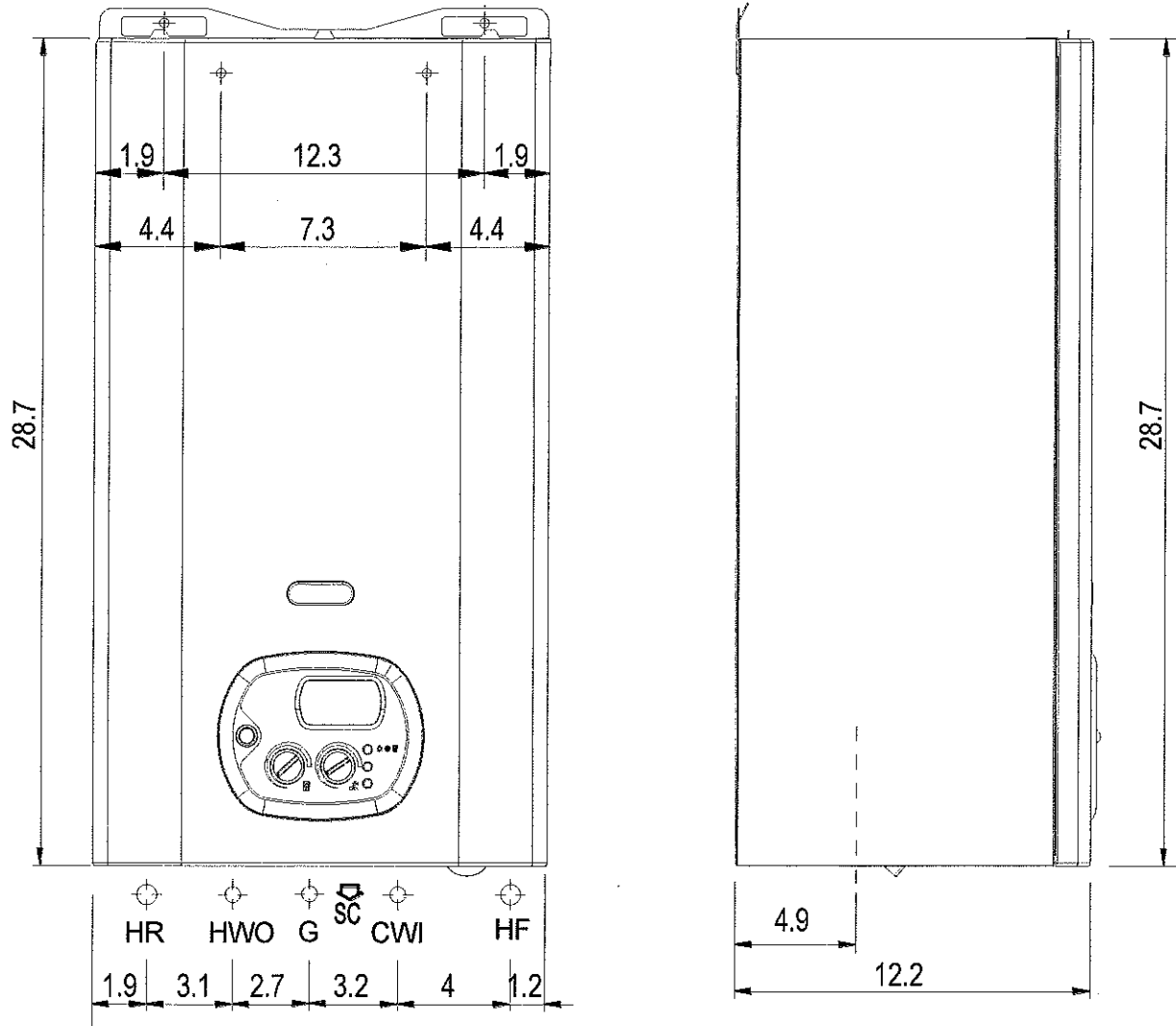

### LEGEND

HR	HEATING RETURN	Ø 3/4"
HF	HEATING FLOW	Ø 3/4"
G	GAS	Ø 1/2"
CWI	COLD WATER INLET	Ø 1/2"
HWO	HOT WATER OUTLET	Ø 1/2"
SC	CONDENSATE DRAIN	Ø 0.98 in

## 2.3 Internal parts of the water heater

### LEGEND

1. SAFETY THERMOFUSE
2. FLUE HOOD
3. PRIMARY CONDENSING HEAT EXCHANGER
4. IONISATION ELECTRODE
5. PREMIX BURNER UNIT (GAS MANIFOLD + BURNER)
6. CONDENSATE DRAIN PIPE
7. HEATING SENSOR
8. HEATING SAFETY THERMOSTAT
9. VENTURI
10. FAN
11. AUTOMATIC AIR VENT VALVE
12. PUMP
13. SAFETY VALVE 3/4
14. SYSTEM DRAIN VALVE
15. AUTOMATIC BY-PASS
16. AIR PRESSURE SWITCH
17. EXPANSION VESSEL
18. IGNITION TRANSFORMER
19. IGNITION ELECTRODE
20. ELECTRONIC GAS VALVE
21. ROOM SEAL CHAMBER BACK SIDE
22. LOW WATER CUT OUT SWITCH
23. CONDENSATE TRAP
24. DIVERTER VALVE ACTUATOR UL/CSA
25. NO-RETURN VALVE
26. WATER PRESSURE GAUGE
27. FILLING TAP

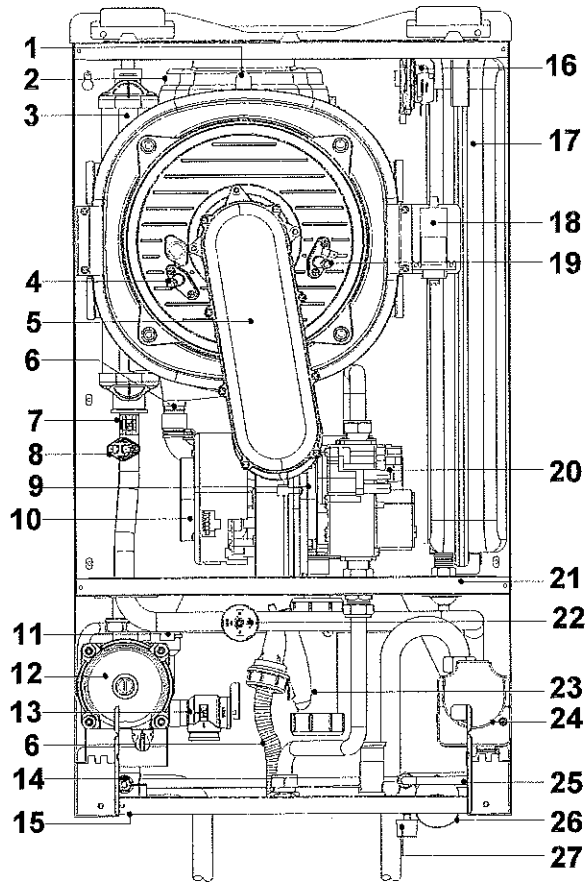

## 2.4 Water circuit

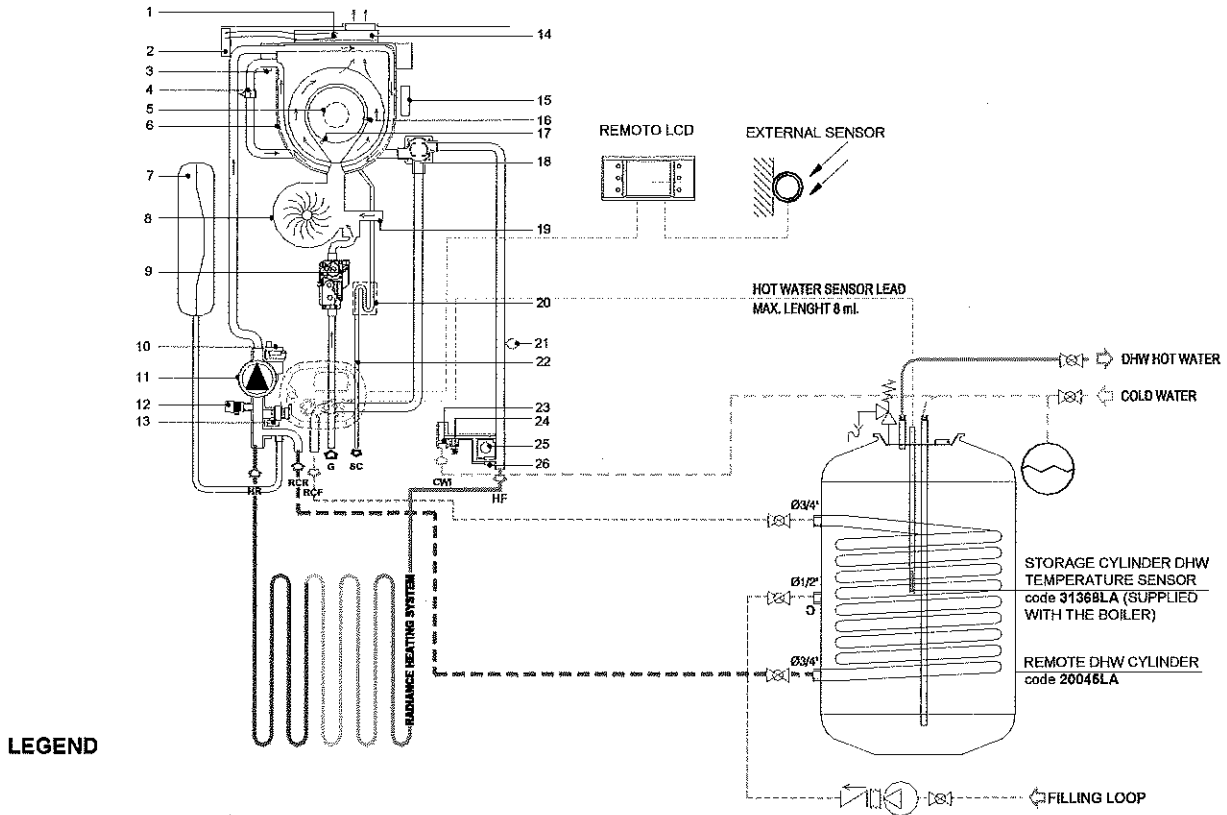

### LEGEND

1. SAFETY THERMOFUSE
2. AIR PRESSURE SWITCH
3. HEATING SAFETY THERMOSTAT
4. HEATING SENSOR
5. PREMIX BURNER UNIT (GAS MANIFOLD+BURNER)
6. PRIMARY CONDENSING HEAT EXCHANGER
7. EXPANSION VESSEL
8. FAN
9. ELECTRONIC GAS VALVE
10. AUTOMATIC AIR VENT VALVE
11. PUMP
12. AIR VENT VALVE 1/4
13. SAFETY VALVE 3/4
14. FLUE HOOD
- 15.
16. IGNITION TRANSFORMER
17. IGNITION ELECTRODE
18. IONISATION ELECTRODE
19. DIVERTER VALVE ACTUATOR UL/CSA
20. VENTURI
21. CONDENSATE TRAP
22. LOW WATER CUT OUT SWITCH
23. CONDENSATE DRAIN PIPE
24. FLOW LIMITER
25. FILLING TAP
26. WATER PRESSURE GAUGE
27. NO-RETURN VALVE

**NOTE**  
THERE IS A STRAINER ON THE HEATING CIRCUIT.  
THE INSTALLATION OF AN ADDITIONAL STRAINER ON THE SECONDARY CIRCUIT IS RECOMMENDED.

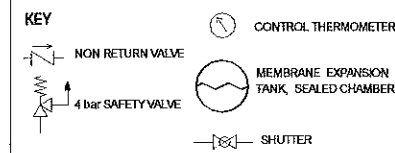

LEGEND	
HR	HEATING RETURN
HF	HEATING SUPPLY
G	GAS
RCR	REMOTE D.H.W. CYLINDER RETURN
CWI	COLD WATER INLET
RCF	REMOTE D.H.W. CYLINDER FLOW
SC	CONDENSATE DRAIN



## 2.5 Circulation pump head/flow graph

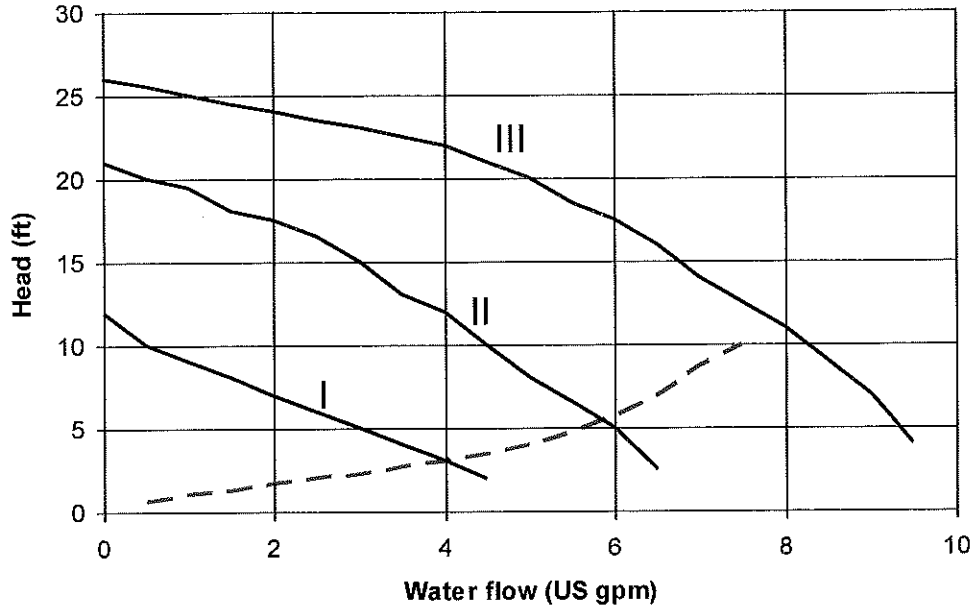

- Pump head
- I, II, III Pump speed
- - - Appliance losses

## 2.6 DIGITECH® printed circuit board – SM 20021

### Technical characteristics

#### Adjustments possible by service personnel only

- Standard (86-176°F) / reduced (77-104°F) central heating temperature
- Water hammer prevention function
- Central Heating timer - (adjustable from 0 to 7,5 minutes)
- Central Heating pump overrun timer
- Domestic Hot Water pump overrun timer
- Minimum Gas pressure setting
- Maximum Heating Load
- D.H.W. temperature setting 95-160°F

#### User settings

- On/Off
- Heating Temperature setting (86-176°F) – (77-104°F)
- D.H.W. temperature setting (95-140°F) – (95-160°F)
- D.H.W. only mode / Heat only mode / D.H.W. + Heat mode selection

#### Operation/Functions display

- Lock-Out
- Water deficiency indicator
- Temperature display

-+ *When the water heater is switched off at the switch on the control panel, the word OFF appears on the display. The D.H.W and central heating frost protection system, nevertheless, remain enabled. If the water heater was previously on, it is switched off and the post-ventilation, pump overrun, circulation pump and three-way valve inactivity protection functions are enabled.*

## 2.7 Control panel

### LEGEND

1. ON/OFF SWITCH
2. HEATING TEMPERATURE CONTROL KNOB
3. D.H.W TEMPERATURE CONTROL KNOB.
4. D.H.W TEMPERATURE BUTTON. KEEP PRESSED FOR 5 SECONDS TO DISPLAY OUTSIDE TEMPERATURE (ONLY WITH OPTIONAL OUTDOOR SENSOR)
5. SERVICE BUTTON.
6. D.H.W, HEAT OR D.H.W./HEAT MODE SELECTION BUTTON.
7. TERMINAL BOARD FOR EXTERNAL WIRING.
8. TEMPERATURE, ERROR CODE AND OPERATING STATUS DISPLAY

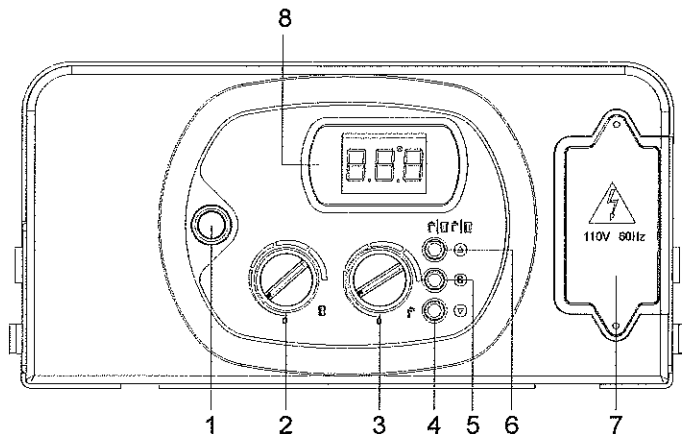

### **3. INSTALLATION (authorized personnel)**

#### **3.1 Reference standard**

Install in accordance with local building and electrical codes.

This appliance meets the requirements of:

American National Standard/CSA Standard for Gas Water Heaters Volume III, Storage Water Heaters with input Ratings above 75,000 Btu per Hour, Circulating and Instantaneous Conforms to ANSI STD Z21.10.3, certified to CSA STD 4.3.

Failure to install a gas appliance correctly and in accordance with the above norms could lead to prosecution. It is in the interest of the installer and safety that the codes are complied with.

The manufacturer's instructions form an integral part of the installation and should be left with the appliance but do not over ride in anyway statutory obligations.

#### **Installation requirements**

Please refer to local and national standards in force with the Country of destination of the product.

### 3.2 Unpacking

- The materials (cardboard) used for packing the appliance are fully recyclable.
- It is recommended that the packing material is only removed prior to installing the combination water heater. The manufacturer will not be held responsible for damage caused by incorrect storage of the product.
- Packing materials (plastic bags, polystyrene, nails, etc.) must not be left within reach of children, in that these items represent a potential hazard.

**A.** Place the packed appliance on the floor (see fig. 1) making sure that the "up" arrow is facing down. Remove the staples and open out the four flaps of the box.

**B.** Rotate the combination water heater 90° while manually supporting it from underneath

**C.** Lift the box and remove the protections. Lift the combination water heater by grasping the rear part and proceed with the installation.

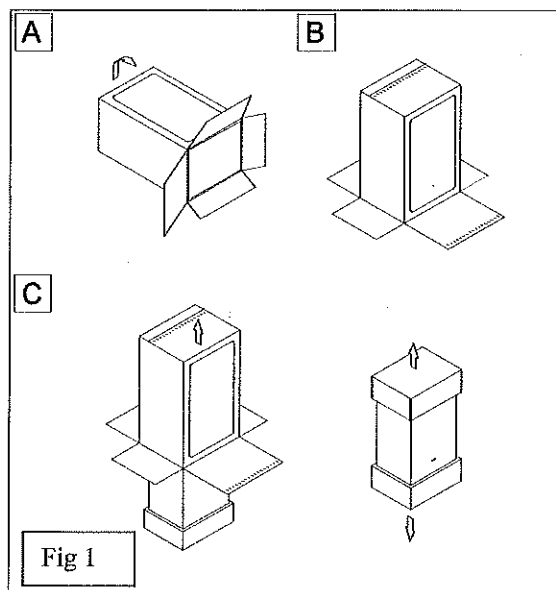

#### STORAGE & HANDLING

Please note that prior to installation the Pensotti North America combination water heaters should be stored in the horizontal position with no more than three combination water heaters to a stack;

Ensure that the combination water heaters are stored in dry conditions and be aware that the carton is a two-man lift;

### 3.3 Installing the combination water heater.

 The appliance must be installed exclusively on a vertical solid wall capable of supporting its weight.

- The combination water heater should be fitted within the building unless otherwise protected by a suitable enclosure i.e. garage or outhouse. (The combination water heater may be fitted inside a cupboard)
- If the combination water heater is sited in an unheated enclosure then it is recommended to leave the ON/OFF switch always in ON position to give frost protection.
- If the combination water heater is installed in a room containing a bath or shower reference must be made to the relevant requirements.
- Appliance is approved for installation on combustible walls.

In order to allow access to the interior of the combination water heater for maintenance purposes, it is important that the minimum distances indicated in figure 1 are respected. To make the installation easier, the combination water heater is supplied with a template to enable the pipe connections to be positioned prior to fixing the appliance to the wall.

To install the appliance, proceed as follows (see fig. 2):

- a. Use a level (of not less than 24" long) to mark a horizontal line on the wall where the appliance is to be fitted.
- b. Position the top of the template along the line drawn with the level, respecting the distances indicated. Then mark the centres of the positions of the two wall screws or anchors. Finally, mark the positions of the water and gas pipes.
- c. Remove the template and install the domestic hot and cold water pipes, the gas supply pipe and the central heating pipes using the fittings supplied with the unit.

Fix the combination water heater to the wall using the bracket and connect the pipes.

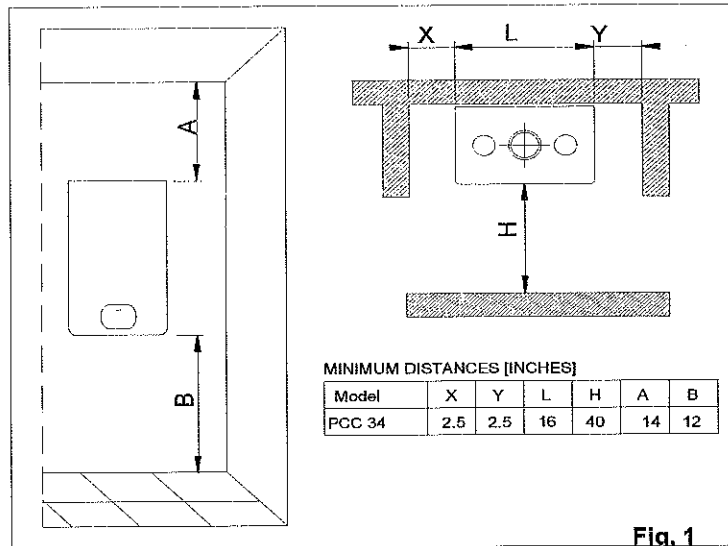

Fig. 1

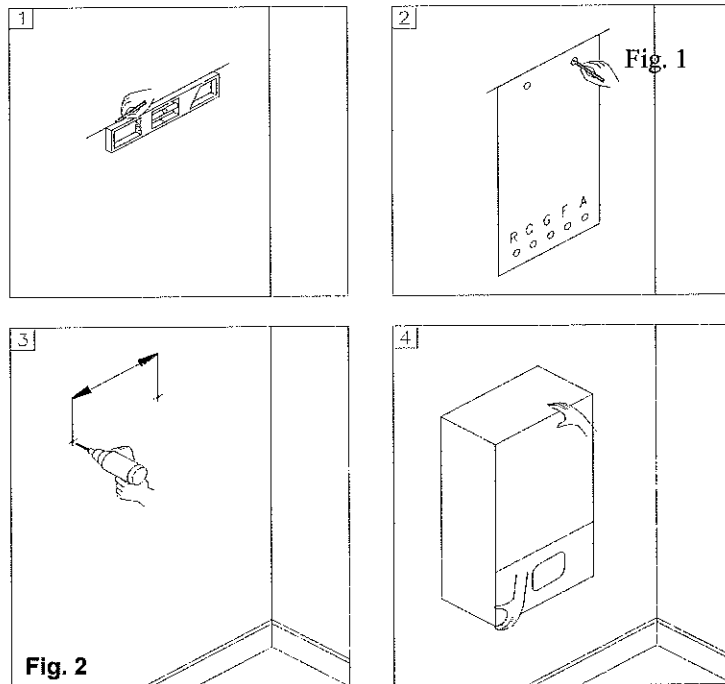

Fig. 2

### 3.4 Water connections

- ⚠ In order to safeguard the heat exchanger and circulation pump, especially in case of appliance replacement, it is recommended that the system is hot-flushed to remove any impurities (especially oil and grease) from the pipes and radiators.
- ⚠ In order to safeguard all waterside components the supplied Fernox Commissioning Kit Must be used in its entirety.
- ⚠ Make sure that the domestic water and central heating pipes are not used to earth the electrical system. The pipes are totally unsuitable for this purpose.
- ⚠ Isolation Valves must be installed on the heating and D.H.W circuits. This will facilitate all maintenance and service operations where the appliance needs to be drained.
  - To prevent vibration and noise coming from the system, do not use pipes of reduced diameter, short radius elbows or severe reductions in the cross sections of the water passages.
  - In order to guarantee the reliability of the water heater a pressure reducing valve and backflow preventer must be installed.
  - To facilitate the installation, the water heater is supplied with an hydraulic connection kit (see fig.2).

A pressure relief valve is installed in this dual purpose water heater that is rated in accordance with and complying with either The Standard for relief Valves and Automatic Shutoff Devices for Hot Water Supply Systems, ANSI Z21.22 or The ANSI/ASME Boiler and Pressure Vessel Code, Section IV (Heating Boilers).The relief valve must be

installed such that the discharge will be conducted to a suitable place for disposal when relief occurs. The discharge line must be installed to allow complete drainage of both the valve and the line. If this unit is installed with a separate storage vessel, the separate vessel must have its own temperature and pressure relief valve. This valve must also comply with The Standard for Relief Valves and Automatic Shutoff Devices for Hot Water Supply Systems. ANSI Z21.22 (in the U.S. only). A temperature relief valve is not required but if one is used, do not install the valve with the probe directly in the flow of water. This may cause unwarranted discharge of the valve.

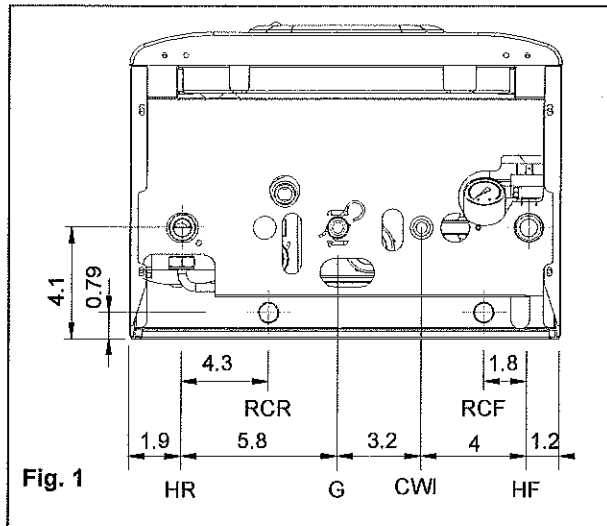

Fig. 1

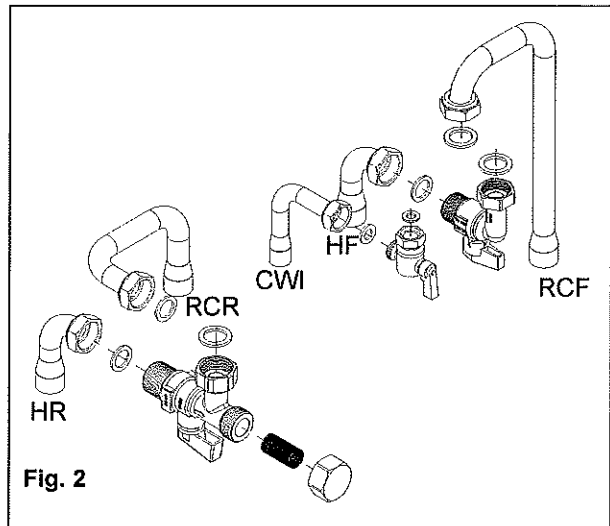

Fig. 2

**LEGEND**

HR	HEATING RETURN	Ø 3/4"
HF	HEATING SUPPLY	Ø 3/4"
G	GAS	Ø 1/2"
RCR	REMOTE D.H.W. CYLINDER RETURN	Ø 3/4"
RCF	REMOTE D.H.W. CYLINDER FLOW	Ø 3/4"
CWI	COLD WATER INLET	Ø 1/2"
SC	CONDENSATE DRAIN	Ø 0.98 in

### 3.5 Domestic Hot Water Circuit

- In order to prevent scaling and eventual damage to the D.H.W heat exchanger, the mains water supply must not have a hardness rating of more than 7 grains/gal (120 ppm). It is nevertheless advisable to check the properties of the water supply and install the appropriate treatment devices where necessary.

The cold water supply pressure at the inlet to the combination water heater must be between 7.25 psi (0.5 bar) and 87 psi (6 bar).

In areas with higher water inlet pressure a pressure reducing valve must be fitted before the boiler.

The frequency of the heat exchanger coil cleaning depends on the hardness of the mains water supply and the presence of residual solids or impurities, which are often present in the case of a new installation. If the characteristics of the mains water supply are such that require it to be treated, then the appropriate treatment devices must be installed, while in the case of residues, an in-line filter should be sufficient.

#### Central heating circuit

In order to prevent scaling or deposits in the primary heat exchanger, the mains supply water to the heating circuit must be treated according to the requirements of local standards.

This treatment is indispensable in the case where the circuit is frequently topped-up or when the system is often either partially or fully drained.

In order to safeguard all waterside components the supplied Fernox Commissioning Kit Must be used in its entirety.

#### Condensate drain

Refer to the city, town or municipality have jurisdiction for codes regarding the proper discharge of condensate.

The condensate drain flexible pipe supplied with the combination water heater must be connected to a proper condensate trap. The condensate discharge into the drainage system is allowed providing a condensate trap (siphon) is installed.

Any condensate discharge pipe work external to the building (or in an unheated part of it) must be insulated to protect against frost. Before switching the combination water heater On, check the correct condensate discharge.

#### Expansion Tank Capacity

Max. System Operating Temperature (°F)	Maximum System Water Content (Gals.)*
100	114
110	85
120	65
130	52
140	43
150	36
160	30
170	26
180	24

⚠ When installing this combination water heater without an indirect water heater the following precautions must be taken.

- Install the supplied piping spurs for an indirect water heater.
- Using 3/4" copper pipe, connect the supply and return together. SEE drawing on next page.
- Set mode selection switch to Heat only position. SEE section 2.7
- Change parameter 01 (P01) to a value of "00"

### 3.6 Piping Diagrams

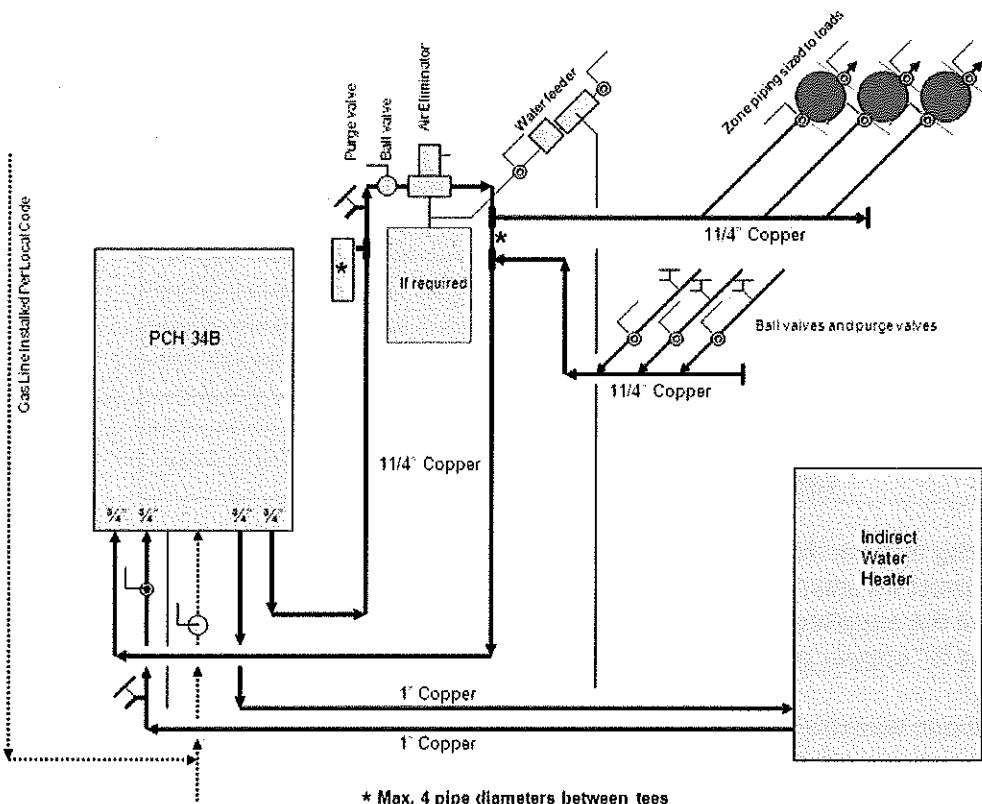
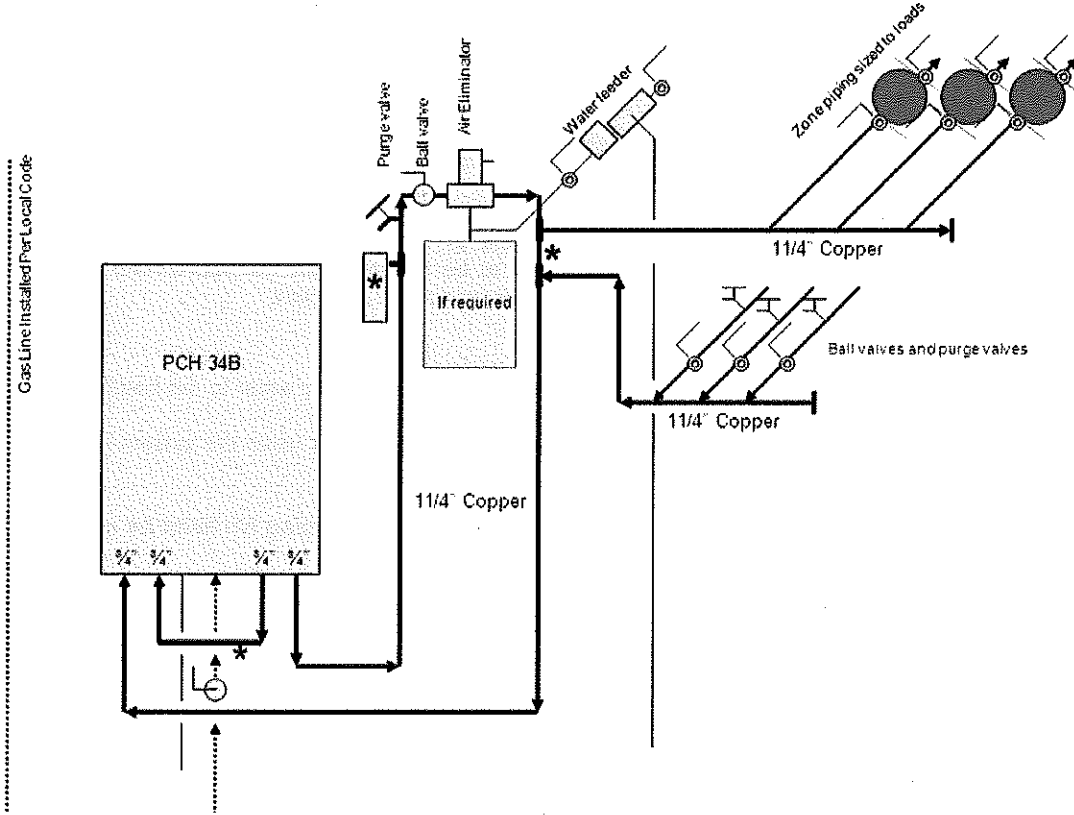

- \* Max. 4 pipe diameters between tees
- \* External Low Water Cut-Off if required by local code



### 3.7 Condensate drain

FAILURE TO INSTALL THE CONDENSATE DISCHARGE PIPEWORK CORRECTLY WILL AFFECT THE RELIABLE OPERATION OF THE DUAL PURPOSE WATER HEATER. The condensate discharge pipe MUST NOT RISE at any point along its length. There MUST be a fall of AT LEAST 2.5° (1" per 20") along the entire run.

1. The condensate outlet terminates in 7/8" nut and seal for the connection of 7/8" plastic overflow pipe which should generally discharge internally into the household drainage system. If this is not possible, discharge into an outside drain is acceptable.
2. Ensure condensate piping, neutralizer, and discharge of condensate complies with any and all local and national codes.
3. The discharge pipe should be run in a proprietary drain pipe material e.g. PVC, PVC-U, ABS, PVC-C or PP.
4. Metal pipe work is NOT suitable for use in condensate discharge systems.
5. The pipe should be a minimum of 7/8" diameter and must be supported using suitably spaced clips to prevent sagging.
6. Any pipe fitted externally must not exceed 10 feet.
7. Any condensate discharge pipe work external to the building (or in an unheated part of it e.g. garage) must be insulated to protect against frost. It is also recommended that the pipe diameter is increased to 1 1/4".
8. If the water heater is fitted in an unheated location the entire condensate discharge pipe should be treated as an external run.
9. In all cases discharge pipe must be installed to aid disposal of the condensate. To reduce the risk of condensate being trapped, as few bends and fittings as possible should be used.
10. When discharging condensate into a soil stack or waste pipe the effects of existing plumbing must be considered. If soil pipes or waste pipes are subjected to internal pressure fluctuations when WC's are flushed or sinks emptied then back-pressure may force water out of the water heater trap and cause appliance lockout.

**Information Only:**

Examples are shown of the following methods of termination:-

- i) to an internal soil & vent pipe
- ii) via an internal discharge branch (e.g. sink waste)
- iii) to a drain or gully
- iv) to a purpose made soak away

**Ensure condensate piping, neutralizer, and discharge of condensate complies with any and all local and national codes.**

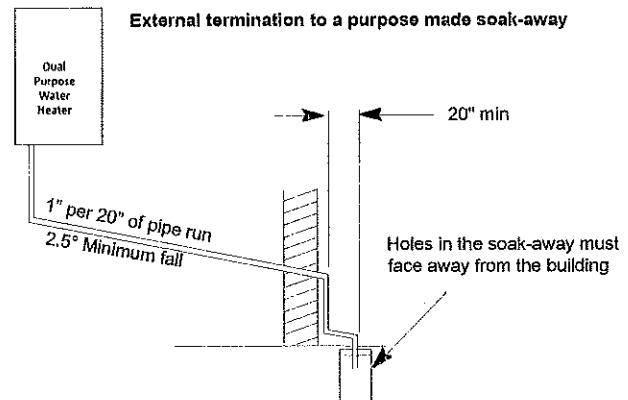
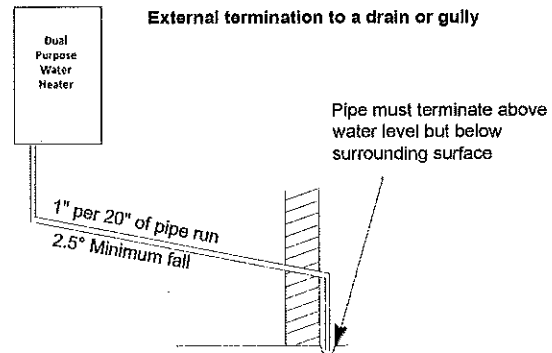
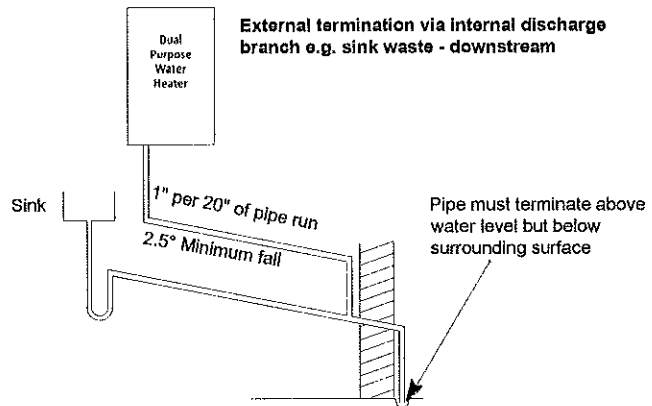
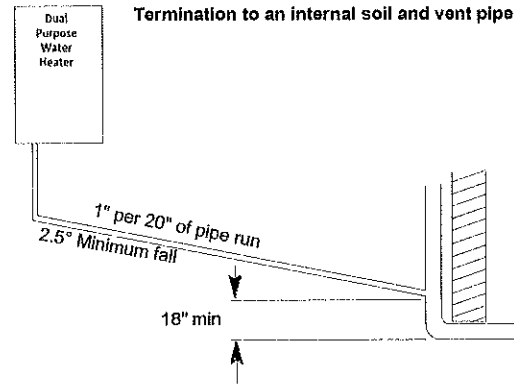

## 3.8 Gas Connection

### 3.8.1 Gas Piping Guidelines

Follow all local codes and/or the most recent edition of the National Fuel Gas Code (ANSI Z223.1/NFPA 54) in the USA or the Natural Gas and Propane Installation Code in Canada (CAN/CSA B149.1).

### 3.8.2 Gas Supply Lines Pressures

The minimum and maximum inlet gas pressures are *Natural Gas Min. 7.00"WC – Max. 14.00"WC. and Propane Gas Min. 11.00"WC – Max. 21.00"WC.*

Gas pressures over and above the specified range will result in adverse performance and dangerous operating conditions; any damage resulting from extreme gas supply pressures will not be covered by the limited warranty.

Until pressure testing of the main gas supply line is completed, ensure the gas line to the PENSOTTI Combination Water Heater is disconnected to avoid any damage to the water heater.

The appliance and its individual shut off valve must be disconnected from the gas supply piping system during any pressure testing of that system at test pressures in excess of 0.5 psi (3.5 kPa)..

The appliance must be isolated from the gas supply piping system by closing its individual manual shut-off valve during any pressure testing of the gas supply system at test pressures equal to or less than 0.5 psi (3.5 kPa).

The gas appliance and its gas connections must be leak tested before placing the appliance in operation. Leaks can be found by using a gas leak detection device or by applying soapy water to all gas fittings. Should bubbles occur, tighten those connections and re-test.

Always purge the gas line for any debris before connecting to the water heater gas inlet.

Never use an open flame to test for gas leaks as property damage, personal injury or death could result.

The maximum inlet gas pressure must not exceed the valve specified by the manufacturer and that the minimum valve listed as for the purposes of input adjustment.

The connection to the gas supply must be carried out by professionally qualified personnel in accordance with the relevant standards.

- **Check the internal and external seals of the gas supply system.**
- A gas shut-off valve and sediment trap must be installed upstream of the appliance .
- Before starting up the water heater, make sure that the type of gas corresponds to that for which the appliance has been set-up.
- The gas supply pressure must be between the values reported on the rating plate.
- Conversion of the appliance from natural gas to LPG or vice versa must be carried out by qualified personnel.
- The power supply cable must be replaced by a qualified electrician. If the cable is damaged in any way, switch off the appliance and have the cable replaced by a suitably qualified electrician.

**When using an electrical appliance, a few fundamental rules must be observed:** Do not touch the appliance with damp or wet parts of the body or when barefoot. Do not pull on the electric wires.

Do not allow the appliance to be used by children or anyone unfamiliar with its operation.

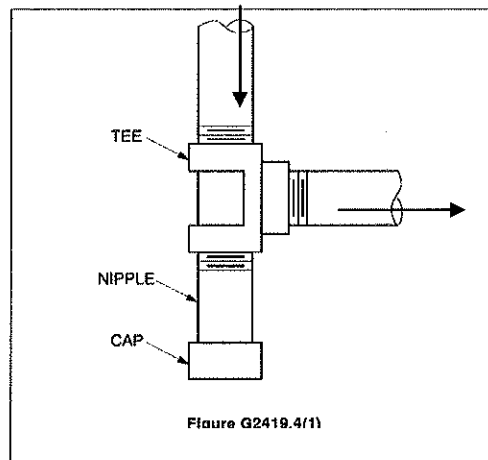

### Natural Gas Pipe Sizing Chart

Length of Pipe In Feet	Size of Schd. 40 Black Iron Pipe in Inches					
	1/2"	3/4"	1"	1-1/4"	1-1/2"	2"
10	108	230	387	793	1237	2259
20	75	160	280	569	877	1610
30	61	129	224	471	719	1335
40	52	110	196	401	635	1143
50	46	98	177	364	560	1041
60	42	89	159	336	513	957
70	38	82	149	317	476	896
80	36	76	140	299	443	840
90	33	71	133	275	420	793
100	32	68	126	266	411	775
125	28	60	117	243	369	700

Natural Gas flow is given in thousands of BTU/hr. - One cubic foot of natural gas = 1000 BTU  
 Nominal pressure at the burner for Natural Gas is 3.5" of water column. (Typical machine supply 5"-7")  
 Pipe length must include additional length for all fittings. Add approximately 5 feet of pipe per fitting  
 Natural Gas Example: A machine with a burner that requires 440,000 BTU would need a 1 -1/4" pipe for a 20' long run.

### Liquid Propane Gas Pipe Sizing Chart

Length of Pipe in Feet	Size of Schd. 40 Black Iron Pipe in Inches					
	1/2"	3/4"	1"	1-1/4"	1-1/2"	2"
10	275	567	1071	2205	3307	6221
20	189	393	732	1496	2299	4331
30	152	315	590	1212	1858	3465
40	129	267	504	1039	1559	2992
50	114	237	448	913	1417	2646
60	103	217	409	834	1275	2394
80	89	185	346	724	1086	2047
100	78	162	307	630	976	1811
125	69	146	275	567	866	1606
150	63	132	252	511	787	1496

LP Gas flow is given in thousands of BTU/hr. - One cubic foot of LP gas - 2516 BTU  
 This chart refers to low pressure LP, after regulation Standard nominal pressure at the burner for  
 Liquid Propane Gas is 11" of water column.  
 Pipe length must include additional length for all fittings. Add approximately 5 feet of pipe per fitting  
 LP Example: A machine with a burner that requires 440,000 BTU would need a 1" pipe for a 20' long run.

## 3.9 Electrical connections

### 3.9.1 General warnings

Follow the electrical code requirements of the local authority having jurisdiction. In the absence of such requirements, follow the latest edition of the National Electrical Code (NFPA 70) in the U.S. or the latest edition of CGA C22.1 Canadian Electrical Code – Part 1 in Canada.

### 3.9.2 Electric Wiring: Ground and Surges

All units come with factory installed 3-pronged (grounded) plug end. The combination water heater can be plugged into any standard electrical duplex outlet close to the unit as it requires only 4 Amps.

If the local jurisdiction requires the unit to be wired directly, remove and discard the factory installed plug. An ON/OFF switch controlling the main power between the breaker and the Water Heater should be provided to facilitate end-user maintenance and servicing. This should be done by a qualified electrician.

The combination water heater must be electrically grounded. Ensure the electrical receptacle, in which the water heater will be plugged into, is properly grounded; if wiring directly, do not attach the ground wire to either the gas or the water piping as plastic pipe or dielectric unions may isolate the water heater electrically.

The use of a surge protector, surge capacitor, line conditioner or equivalent is recommended to protect the appliance from power surges.

If a generator is to be used as "backup" power care must be taken that a line conditioner is used to protect the appliance from erratic voltage.

If the water heater is to be installed in a structure utilizing a emergency stand-by generator, the installation of a surge capacitor, surge protector, line conditioner or equivalent is required.

If the water heater is to be installed in a structure where frequent power outages are experienced the installation of a surge capacitor, surge protector, line conditioner or equivalent is required.

Do not energize electric power to the unit until all plumbing and gas piping is complete and the combination water heater has been filled with water.

The electrical supply required by the water heater is 120VAC at 60Hz with a maximum 4A rating with proper grounding. Protection must be in place to prevent the Combination Water Heater from being exposed to voltage in excess of 130VAC Max or 95VAC Min.

**Damage caused by excessive voltage is not covered under warranty.**

DO NOT connect 220-240VAC and any other voltage to this PENSOTTI Combination Water Heater. This will damage the combination water heater and void the warranty.

Do not disconnect the power supply when the unit is in normal operation.

If there is a power failure in cold weather areas, the freeze prevention system in the water heater will not operate and may result in freezing of the heat exchanger; in cold weather areas where power failures are common, you must completely drain the unit to prevent damage if the power will be off for any extended period of time.

**Damage caused by freezing is not covered under warranty.**

CAUTION : Label all wires prior to disconnection when servicing controls. Wiring errors can cause improper and dangerous operation. Verify proper operation after servicing.

The connection to the main power supply must be carried out by professionally qualified electrical personnel, registered in accordance with current legislation and local authorities.

Always check to make sure that the appliance has an efficient ground system. This requirement is only satisfied if it has been properly connected to an efficient ground system installed in accordance with the requirements of current safety standards and carried out by professionally qualified personnel.

This basic safety measure must be checked, verified and carried out by professionally qualified personnel. Have the electrical system checked by a qualified electrician. The manufacturer will not be held liable for any damage or injury caused as a result of an inefficient or faulty ground system.

- Ensure the domestic power supply is checked by a qualified electrician to ensure that it can support the maximum power absorption of the appliance, as indicated on the rating plate. In particular, make sure that the cable sizes are adequate for the power absorbed by the appliance;
- The power supply cable must be replaced by a qualified electrician. If the cable is damaged in any way, switch off the appliance and have the cable replaced by a suitably qualified electrician;

**When using an electrical appliance, a few fundamental rules must be observed:**

Do not touch the appliance with damp or wet parts of the body or when barefoot.

Do not pull on the electric wires.

Do not allow the appliance to be used by children or anyone unfamiliar with its operation;

**If the unit fails to re-start after any fault, unplug the unit for 30 seconds, then re-plug in the unit and try to restart with the on/off switch. If the unit fails to restart, call a qualified Technician for service.**

## Remote control connection

**Connect the power supply to the terminal board inside the control panel as follows:**

- a. Switch off the power supply at service switch or breaker.
- b. Remove the front case panel of the boiler.
- c. Slacken the screws and remove plate A (see fig. 1).
- d. With the plate removed, connect the wires to the terminal board B as follows:
  - Connect the earth wire (normally coloured green/yellow) to the terminal marked with the earth symbol "⊥".
  - Connect the neutral wire (normally coloured blue) to the terminal marked with the letter "N".
  - Connect the live wire (normally coloured brown) to the terminal marked with the letter "L".
  - Terminals identified by the letters:
    - Ta ⇒ Room thermostat or End Switch
    - Se ⇒ Outside temperature sensor

Ta terminals are 24V DC. Only a non-power robbing, battery operated thermostat or dry set of contacts can be installed on Ta terminals.

When the wires have been connected, place plate "A" back to position. Switch the power supply back on.

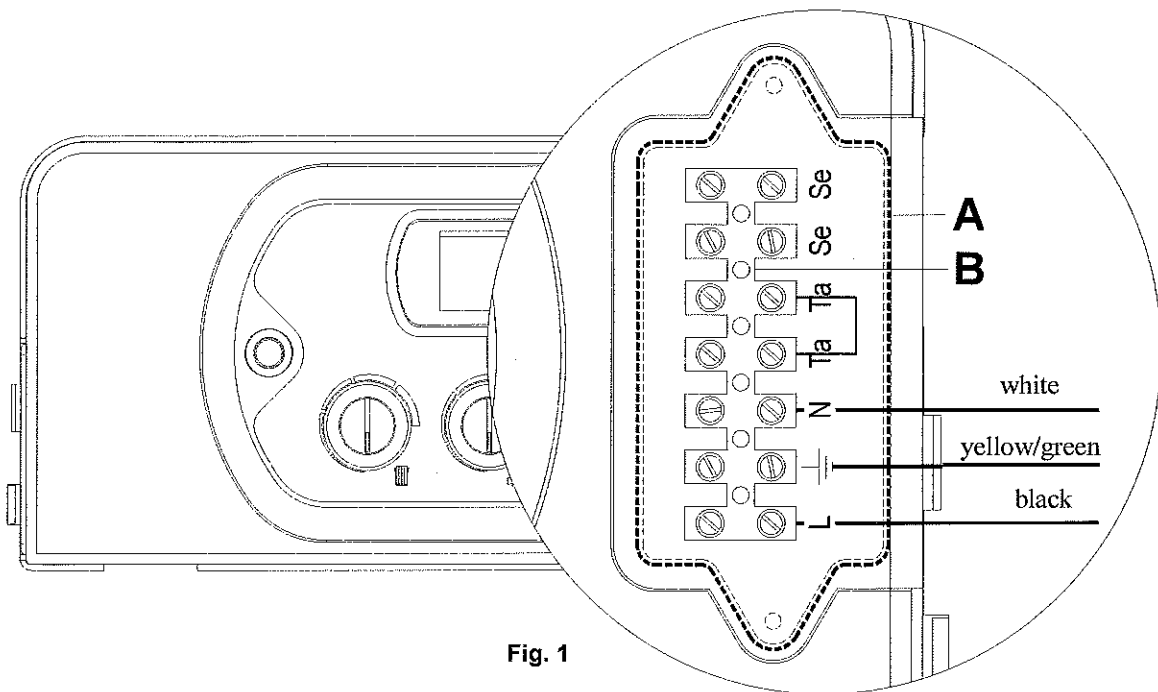

Fig. 1

### 3.10 Venting

Improper venting of combination water heater can result in excessive levels of carbon monoxide which can result in severe personal injury or death. This combination water heater must be vented in accordance with the "Venting of Equipment" section of the latest edition of the ANSI Z223.1 / NFPA 54 Natural Gas Code and/or the "Venting systems and air supply for appliances" section of the latest version of the CAN/CSA B149.1 Natural Gas and Propane Installation Code in Canada and in accordance with all applicable local building codes.

#### Venting Guidelines

For best results, keep the vent system as short and straight as possible.

Locate the combination water heater as close as possible to the vent termination.

The combination water heater vent must not be common vented with any other gas appliance or vent stack.

Slope vent upwards towards the vent terminal at a rate of 1/8" per foot (1% slope).

Vent termination must be a minimum of 12" above grade or expected snowfall.

Vent and air intake pipe must be supported every 4 feet of horizontal run and every 5 feet of vertical run.

#### PENSOTTI and Direct Vent

All PENSOTTI Combination Water Heaters are prepared at the factory to be direct vent (sealed combustion) units which draw all of their required combustible air directly from outside the building.

All PENSOTTI Combination Water Heaters use a 3/5" concentric vent (polypropylene inner exhaust pipe with a painted aluminum outer pipe).

**The exhaust vent material must only be polypropylene. Do not use anything other than polypropylene as a means of venting flue gases from the Pensotti Combination Water Heater.**

#### Contaminated Make-Up Air Will Damage the Unit

We recommend not operating the combination water heater in an area that is or will be under construction or renovation.

The PENSOTTI warranty will not cover damage and premature wear caused to the unit due to installation in a contaminated environment.

All concentric venting must be checking for cross contamination using a combustion analyzer inserted into the makeup air test port on the venting adapter. Analyzer must NOT read anything in excess of "0 ppm" Carbon Monoxide (CO). Any leaks must be repaired before continuing operation of the water heater.

Warranty will not be available if the water heater is used for construction heat.

# Venting Pictures & Illustrations

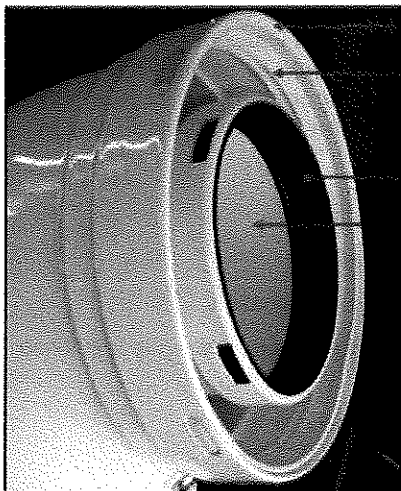

- 5" Painted Aluminum
- EPDM Seal
- EPDM Seal
- 3.15" Polypropylene Pipe 240 Degree F Rating

Maximum Equivalent Vent Lengths

PC 18	29.25 Feet
PC 34	26 Feet
PC 50	16.25 Feet

### Equivalent Fittings Lengths

90 Degree Elbow	2.6 Feet
45 Degree Elbow	1.64 Feet
Extensions/Terminals	Measured Lengths

On **Horizontal** vent systems the 2/4" to 3.15/5" transition and first elbow are not calculated into the equivalent length of run.

On **Vertical** vent systems the vent termination is not calculated into the equivalent length of run.

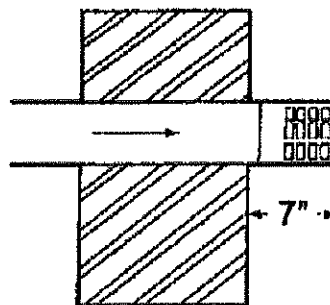
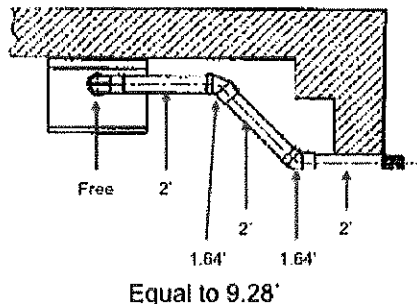
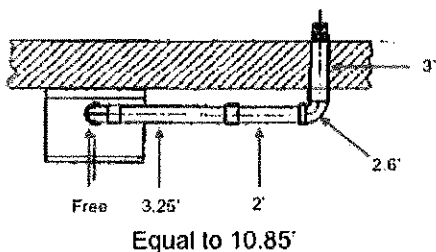



Rotate Transition To Desired Position And Secure Using Screws Provided

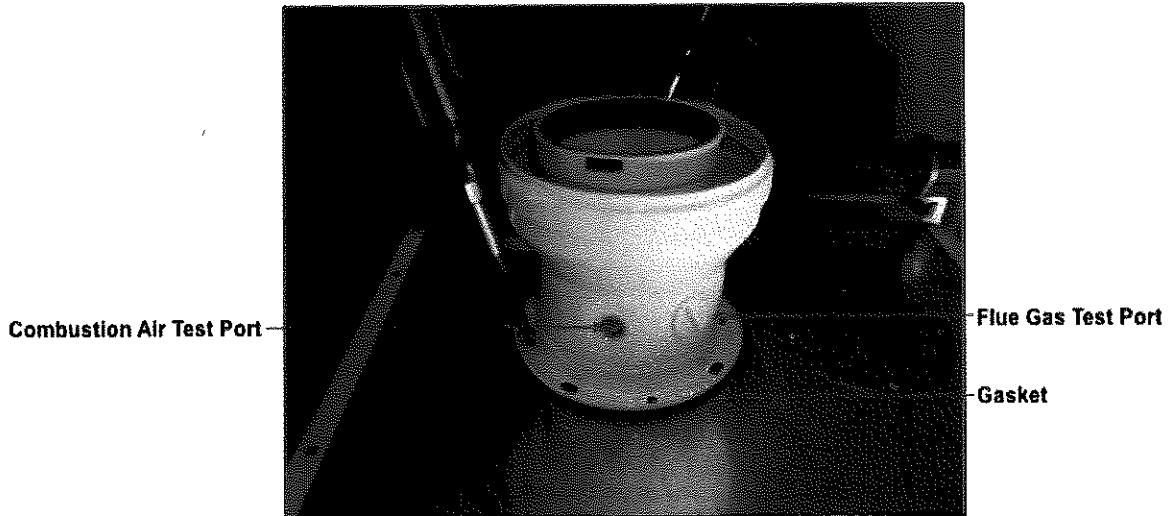

Included With Each Combination Water Heater Is A PAHVK Horizontal Kit



Lubricate Rubber Gaskets, with Supplied Silicone Lubricant, and Install Venting Components. Fully Seat Then Secure With 2 - No. 8 x 1/2" Zinc Coated Screws

**Do not over lubricate**  
**Assemble immediately after lubrication**

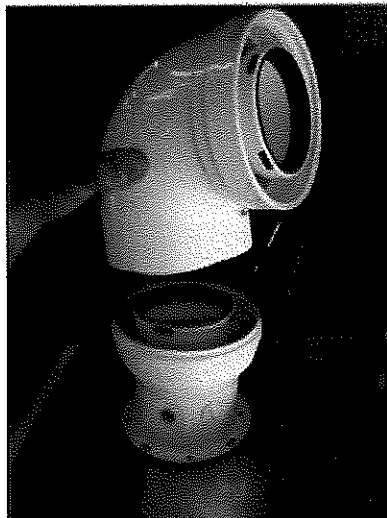

## Pensotti Solenne Series Fastening of Venting Components

All concentric venting systems installed with Pensotti Solenne condensing wall mounted boilers must be fastened together to reduce the chance of the venting components separating.

Two screws must be fastened through the outer air intake pipe, behind the gasket, at equal distances apart. The screws must be no longer than No. 8 x 1/2" sheet metal screws and must be zinc coated or stainless steel.

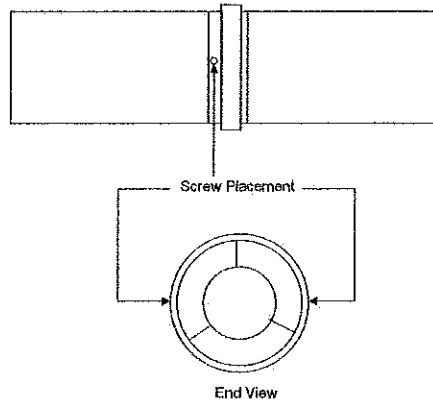

Be sure not to pierce the inner poly exhaust pipe.  
Failure to comply with these instructions could result in property damage, personal injury or loss of life.

12" Clearance Suggested From The Top Of The Appliance To Ceiling

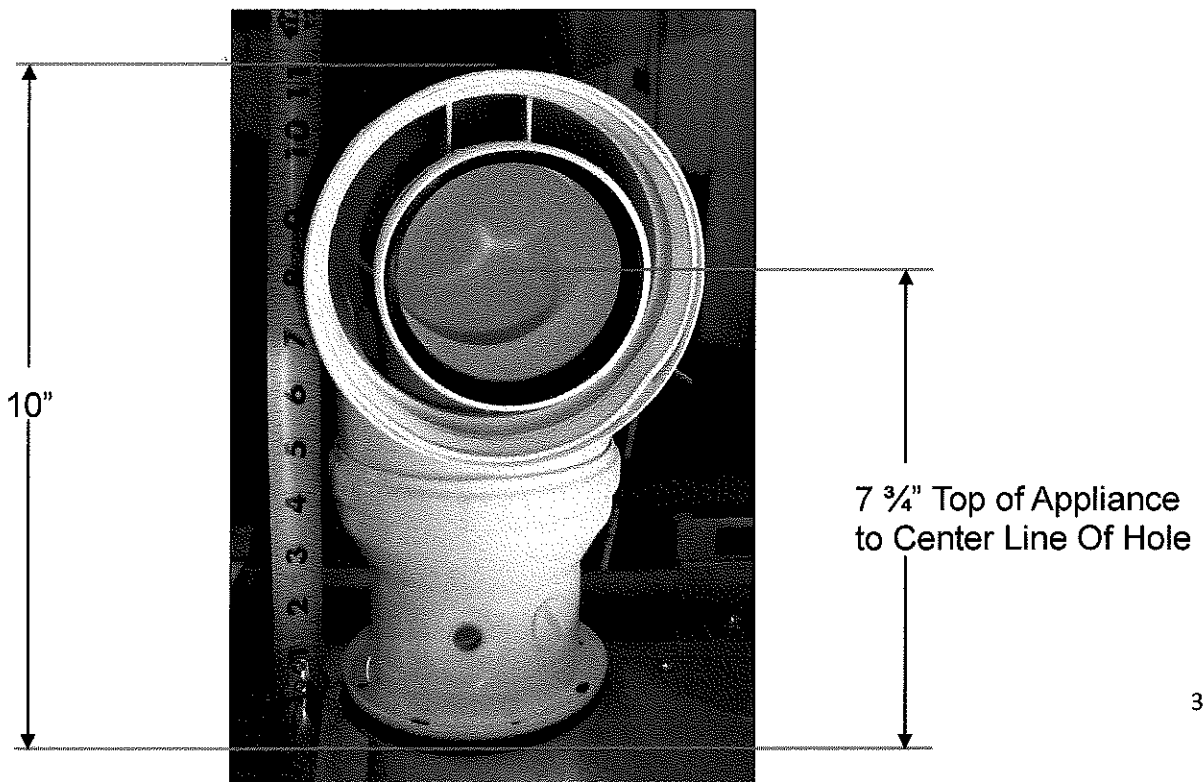

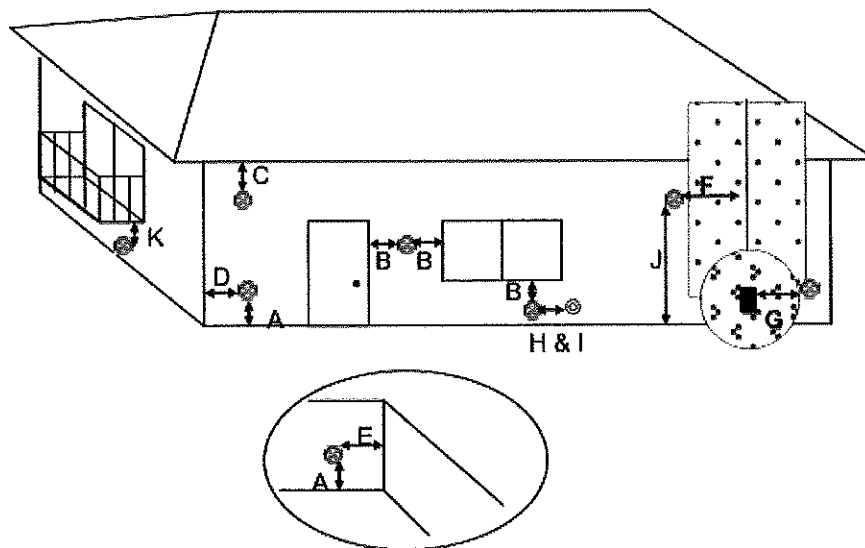

Direct Vent Termination Minimum Clearances	
A = 12"	Clearance above grade, snowline, deck, porch or balcony
B = 12"	Clearance to window or door that may be opened
C = 24"	Vertical clearance to ventilated and unventilated soffit within a 2' distance horizontally from center line of DV termination
D = 12"	Minimum distance to outside corner
E = 18"	Minimum distance to inside corner, included walls and fences.
F = 48"	Not to be installed above a gas meter/regulator within F from the center line of the meter/regulator
G = 48"	Minimum clearance to service regulator vent outlet, gas meter or electrical meter
H = 12"	Clearance to non-mechanical inlet air opening into the building
I = 36"	Clearance to a mechanical air inlet into the building
J = 84"	Minimum distance above a paved sidewalk or driveway located on public property. If terminal is located between two single family residences with a sidewalk or driveway between; the same 84" clearance applies.
K = 24"	Minimum clearance beneath porch, deck, veranda or balcony, only if the area below is completely open on at least two sides.

State and local codes may require different clearances, consult the local authority having jurisdiction in each area for details.

The vent hood must be installed on the leeward side of the structure. Avoid installing the vent hood on the side of the structure receiving normal prevailing winds.

The termination shall be located so that flue gasses, or condensate from the flues gasses, are not directed as to jeopardize people, building materials, building construction, siding or soffits. Flue gasses from the termination shall not be allowed to enter any type of structure.

The termination shall be located no less than 48" above or to the side of the exhaust for any other oil, gas or solid fuel appliance

## 4. COMMISSIONING THE APPLIANCE

### 4.1 General warnings

The following operations must be carried out by professionally qualified personnel, registered in accordance with current legislation.

Use of a properly calibrated electronic combustion analyzer **MUST** be used when installing, servicing or converting this Combination Water heater from Natural Gas to LP or from LP to Natural Gas.

The water heater leaves the factory pre-set and tested for burning either Natural Gas or LPG. Nevertheless, when starting the water heater for the first time, make sure that the information on the rating plate corresponds to the type of gas being supplied to the water heater.

Once the system has been filled and the necessary adjustments made, remember to tighten the screws of the gas valve test point and make sure that there are no gas leaks from the test point and from any pipe fittings upstream of the gas valve.

#### ■ Preliminary operations

Switching the water heater on for the first time means checking that the installation, regulation and operation of the appliance are correct:

Check that the rating on the rating plate corresponds to that of the mains supply networks (gas, electricity, water));

Check that the power supply voltage to the water heater complies with the rating plate (120 V – 60 Hz) and that the live, neutral and ground wires are connected properly. Also make sure that the ground connection is sound;

Check that the gas supply is correctly sized for the flow rate required by the water heater and that it is fitted with all the safety and control devices stipulated by current regulations;

Check that the supply of combustion air and exhaust and condensate discharge systems are functioning correctly and in line with current law and national and local standards;

Check for the presence of permanent aeration/ventilation openings as required by current law for the type of appliances installed;

Check that the exhaust vent and its connections to the termination comply with the requirements of current law and national and local standards for the type of appliances installed;

Make sure that any central heating shut-off valves are open;

Check that the condensate drain system, including outside the water heater (exhaust system condensate collection devices), allows the condensate to flow freely to the drain.

Check that there are no flammable materials or liquids in the immediate vicinity of the water heater;

*Flush out both primary and domestic hot water circuits (see 4.3 "Flushing the system").*

## 4.2 Filling the system

⚠ Check the properties of the water supply and install the appropriate treatment devices if the mains water has a hardness rating more than 7 grains/gal. (120 ppm) in order to prevent scaling and eventual damage to the D.H.W heat exchanger.

⚠ A pressure reducing valve and backflow preventer must be installed.

⚠ Use only clean tap water to fill the system.

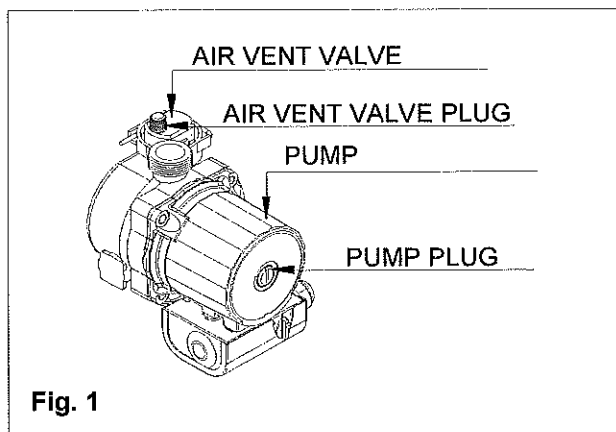

Fig. 1

Once the water pipes have been connected, close the gas feed valve and fill the system as follows:

- Check that the circulation pump runs freely;
- Check that the plug of the air vent valve has been slackened slightly to allow air to escape from the system (fig.1);
- Purge all air from primary heat exchanger using the manual air vent.
- Open the main domestic water supply valve;
- Unscrew the plug on the pump to remove any trapped air, check that the pump is free then re-tighten it when water starts to flow out;
- Open the air vents on the radiators and monitor the air evacuation process. When water starts to flow out of the radiators, close the air vents;

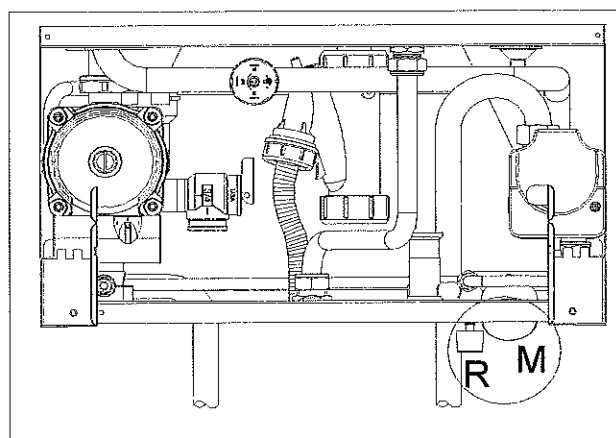

Fig. 2

- Use the pressure gauge **M** (fig. 2) to check that the system pressure reaches 14 psi (1 bar) and that the code H2O does NOT appear on the control panel display (see 2.7 section 'Control Panel');
- If, after the above operations, there is a reduction in the pressure, re-open the filling tap **R** until the pressure gauge reads 14 psi (1 bar) and that the code H2O disappears on the control panel display;
- On completion, make sure that the filling tap **R** is perfectly closed.

### Emptying the central heating system

Whenever it is necessary to empty the system, proceed as follows:

- turn off the main power supply switch;
- wait for the appliance to cool down;
- turn the system drain tap RS (see fig. 2) and use a container to collect the water that runs out;

### Emptying the domestic hot water system

Whenever there is danger of freezing or any other occurrence, the hot water system could be emptied in the following way:

- Shut off the water at the mains;
- Open all hot and cold water taps;
- Empty from the lowest point (where possible).

### 4.3 Flushing the system

**Failure to flush and add inhibitor to the system will invalidate the appliance warranty.**

**All systems must be thoroughly drained and flushed using additives – corrosion inhibitors and flushing agents/descalers. Pensotti requires the use of the supplied Fernox Commissioning Kit or individual containers of Fernox F3 or F5 cleaner and F1 protector. Follow Fernox installation instructions. Failure to use Fernox F3 or F5 cleaner and F1 protector could void the warranty for all waterside components.**

#### To flush out the primary side of this unit

- Fill the water heater as per the filling instructions.
- Using a drain off cock on the lowest point of the system allow the water to drain from the system and water heater.
- In order to flush the system correctly turn off all radiators open the filling loop and drain cock simultaneously and allow the water to flow through the water heater.
- Open each individual radiator allowing water to flow through then turn that radiator off and repeat for all radiators on the system.
- Turn off the filling loop and close the drain cock open all radiators and open the filling to fill the system.
- Continue to fill the system until the pressure gauge reads in the Green section of the gauge (14.5 psi (1 bar)).

#### To flush out domestic hot water circuit

- Open all hot water outlets.
- Turn on inlet group supply so water enters the water heater; leave to fill until water is released from the hot water outlets. Turn off all hot water outlets.
- Connect a hosepipe to the cylinder drain cock and open the drain cock.
- Allow water to flow through the water heater and out of the drain cock.
- Turn off water supply, disconnect the hosepipe, close the drain cock and refill the water heater.

### 4.4 Filling the condensate trap

The condensation trap must be pre-filled when starting the combination water heater for the first time in order to prevent flue gases from flowing back through the trap.

The filling operation is carried out as follows (see fig. 1):

- Remove plug **T** and fill the trap **S** three quarters full with water;
- Replace plug **T** and connect the drainpipe **P** into a condensate discharge trap conforming to current legislation;

**Attention!** It is recommended to clean the condensate trap, after a few months of appliance operation, to remove deposits/residuals left after the first condensate passage within the units new components that may interfere with the correct operation of the trap itself.

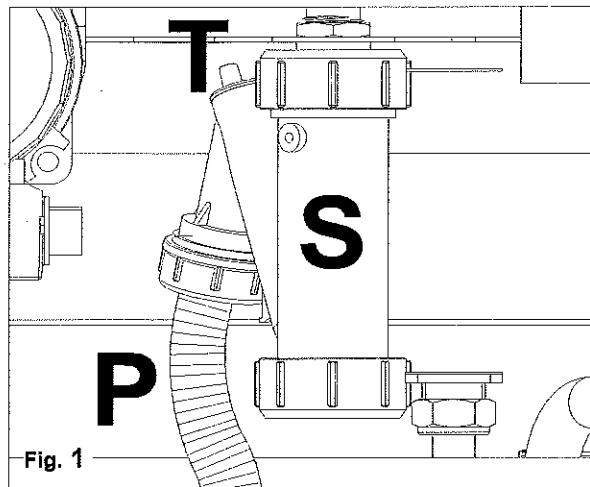

## 4.5 Starting up the water heater

Once the system has been filled, proceed as follows:

- Check that the exhaust flue is free of obstructions and correctly connected to the water heater;
- Switch on the power supply to the appliance;
- Open the gas isolation valve;
- Place switch **1** in the **ON position** (see 2.7 "Control Panel"), after a few seconds the circulating pump will start to run;
- Use button **6** to set the D.H.W,

HEAT or D.H.W./HEAT function. The symbols  will light up (fixed light) to indicate that the water heater is working;

- The automatic ignition system will then light the burner. This operation is repeated for 3 times. It may however be necessary to repeat the operation in order to eliminate all the air from the gas pipes. To repeat the operation, wait approximately three minutes before re-attempting to light the water heater. To reset the water heater Switch off switch **1** (see 2.7 "Control Panel") and switch it back on again and repeat the lighting procedure;
- With the water heater ignited, if the system still emits noises, the operations must be repeated until all the air has been removed from the gas piping;
- Check the water pressure in the system. If the pressure has fallen, introduce water into the appliance until the code "H2O" **disappears on the display** and the pressure gauge reads in the Green section of the gauge (14.5 psi (1 bar)) on completion;
- Check gas pressure at gas valve inlet pressure tap. SEE Fig 2. Set gas pressure to proper level at the regulator (Refer to section 2.1 Technical Data). Gas pressure adjustments must be performed while the appliance is in "Flue Test Function" mode (maximum firing rate). Do NOT make any adjustments to the gas valve itself.
- Unscrew the plug and insert an analyser in the exhaust sampling point **PF**, SEE Fig. 1, (air intake manifold is missing in the drawing to provide a clear view of the V screw) to check the CO<sub>2</sub> value. Make sure that the value complies with that reported in table 1 while the appliance is in "Flue Test Function" mode;
- If the CO<sub>2</sub> value does not correspond to the specified value, adjust screw **V** (see fig. 1) on the venturi clockwise to reduce the CO<sub>2</sub> value or counter-clockwise to increase it;

Table n°1

Gas type	CO <sub>2</sub> %
Natural Gas - G20	9.18
Liquid Propane Gas - G 31	10.3

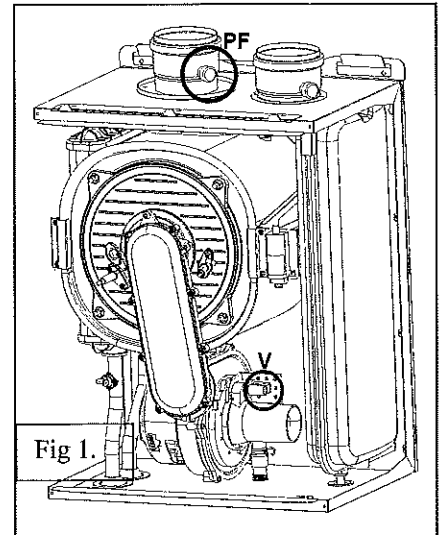

Fig 1.

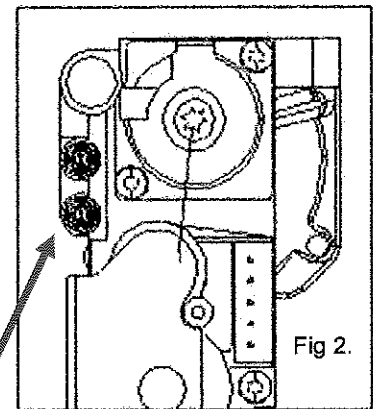

Fig 2.

Inlet Pressure Tap

## 5. REGULATING THE APPLIANCE

### 5.1 Parameters table

PARAMETER N°	TYPE OF OPERATION	PARAMETER VALUE	FUNCTION
1	Selects the type of water heater	00 01 02 03	PCC 34 or PCH 18 PCI 18/8 or PCI 34/20 PCH 34/B, PCH 18/B or PCH 50/B D.H.W. Temperature 95-160 F (PCC 34 only)
2	Selects the type of gas	00 01	Natural gas Propane
3	Sets the central heating Temperature Displayed in °C only	00 01	Standard (86-176F) Reduced (77-104F)
4 <sup>1</sup>	Selects pump mode during heating phase	00 01	Standard ( 3' pump overrun) Permanent (pump runs continuously)
5	Water hammer cycle prevention	00 01	Off On
6	Central heating timer	00-90 (default = 36)	Electronically timed heating differential. Expressed in steps of 5 sec (factory set at 36 x 5 = 180 sec)
7	Central heating pump overrun timer	00-90 (default = 36)	The overrun timer can be modified. Expressed in steps of 5 sec (factory set at 36 x 5 = 180 sec)
8	D.H.W pump overrun timer	00-90 (default = 18)	The overrun timer can be modified. Expressed in steps of 5 sec (factory set at 18 x 5 = 90 sec)
9	<b>Not Applicable</b>	-	Not applicable for premix water heaters
10	<b>Not Applicable</b>	-	Not applicable for premix water heaters
11	<b>Not Applicable</b>	-	Not applicable for premix water heaters
12	<b>Not Applicable</b>	-	Not applicable for premix water heaters
13	D.H.W. priority function (2 min delay on D.H.W. function)	00 01	Off On (Recommended)
14 <sup>4</sup>	Selects the type of burner	00 01 02 03	Atmospheric (not premix) 18 kW 34 kW 50 kW
15	Zone management activation <b>Not Applicable</b>	00 01	Off On
16	Telephone control <b>Not Applicable</b>	00 01	Off On
17	Minimum fan speed setting	55 Hz (Natural Gas) 52 Hz (Propane)	To set the minimum frequency value (Hz) for the fan operation
18	Maximum fan speed setting	164 Hz (Natural Gas) 155 Hz (Propane)	To set the maximum frequency value (Hz) for the fan operation
19	Minimum fan speed setting (Central Heating)	55 Hz (Natural Gas) 52 Hz (Propane)	To set the minimum frequency value (Hz) for the fan operation in heating mode.
20	Maximum fan speed setting (Central Heating)	164 Hz (Natural Gas) 155 Hz (Propane)	To set the maximum frequency value (Hz) for the fan operation in heating mode
21	Ignition sequence setting	110 Hz (Natural Gas) 130 Hz (Propane)	To set the fan frequency value (Hz) at the ignition
22	Fan frequency value display	00 01	Off On (for 10 min. time)

#### NOTES:

- 1 - Activate only for "heating only" water heaters;
- 2- When the parameter value 01, 02 and/or 03 is set, parameters from no.17 to 22 are automatically activated and water heater settings are carried-out in through these parameters (in Hz). Once the parameter value has been set according to the water heater output, the P.C.B will automatically adjust the maximum and minimum values.



## 5.2 Setting the parameters

To modify the pre-set values of the parameters reported in the previous table, open the parameter settings menu as follows:

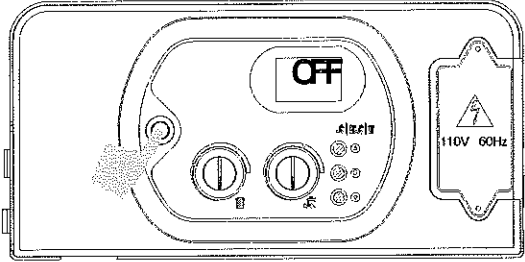

1. Place the On/Off switch in the OFF position.

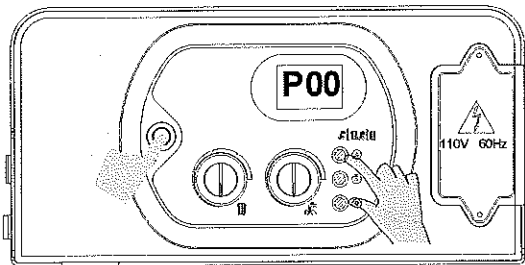

2. Activate the On/Off switch while keeping buttons '+' and '-' pressed. Wait for "P 00" to appear on the display.

3. Release buttons '+' and '-'.

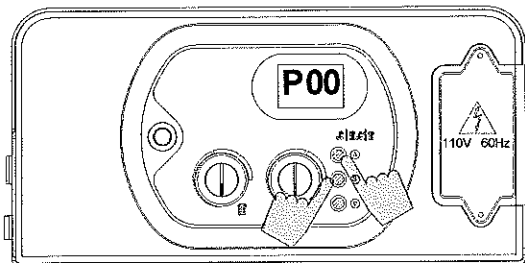

4. Keep button 'S' pressed and use button '+' and '-' to select the parameter to modify.

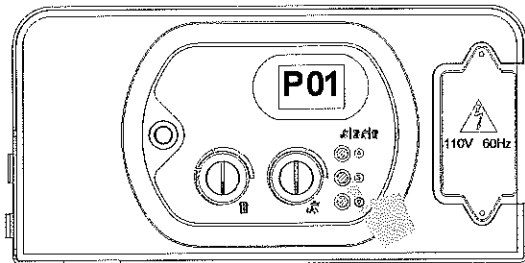

5. Release button 'S', then re-press and release it. The display will indicate the value of the parameter to modify.

Adjust the value of the parameter using the procedure described in the following pages.

To enter the parameters menu, follow the previously described procedure (steps 1-5).

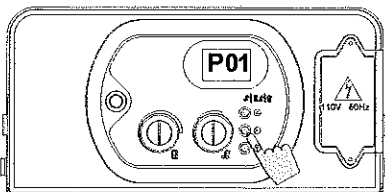
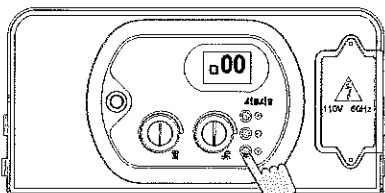

**PARAMETER 1 – TYPE OF BOILER**

6. Use buttons '+' and '-' to modify the value of the parameter:

- 00 = PCC 34 or PCH 18;
- 01 = PCI 18/8 or PCI 34/20;
- 02 = PCH 34/B, PCH18/B or PCH 50/B;
- 03 = DHW Temperature 95-160°F – PCC 34 Only

7. Press and release button 'S' to confirm. The parameter number (1) will appear on the display.

8. Switch off the appliance and switch it back on again to render the new parameter operative.

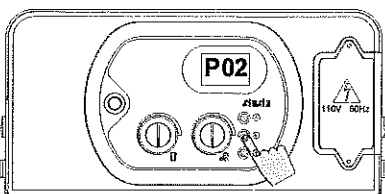
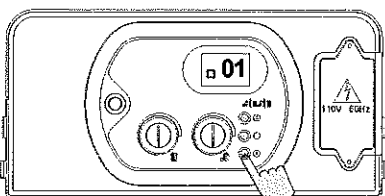

**PARAMETER 2 - GAS SUPPLY**

6. Use buttons '+' and '-' to modify the value of the parameter:

- 00 = natural gas
- 01 = lp gas

7. Press and release button 'S' to confirm. The parameter number (2) will appear on the display.

8. Switch off the appliance and switch it back on again to render the new parameter operative.

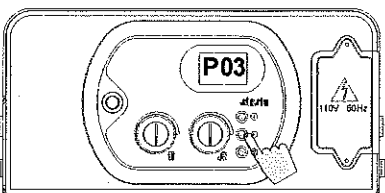
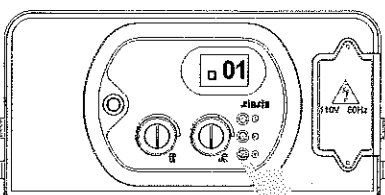

**PARAMETER 3 – CENTRAL HEATING TEMPERATURE**

**Displayed in °C only**

6. Use buttons '+' and '-' to modify the value of the parameter:

- 00 = standard (86 – 176°F)
- 01 = reduced (77 – 104 °F) for under-floor heating

7. Press and release button 'S' to confirm. The parameter number (3) will appear on the display.

8. Switch off the appliance and switch it back on again to render the new parameter operative.

**PARAMETER 4 – CENTRAL HEATING PUMP**

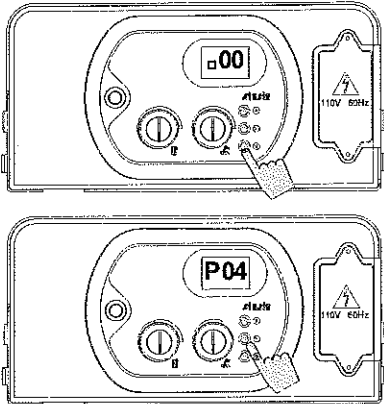

6. Use buttons '+' and '-' to modify the value of the parameter:  
 00 = standard (3 minute default overrun)  
 01 = permanent (always running)
7. Press and release button 'S' to confirm. The parameter number (4) will appear on the display.
8. Switch off the appliance and switch it back on again to render the new parameter operative.

**PARAMETER 5 – WATER HAMMER PREVENTION**

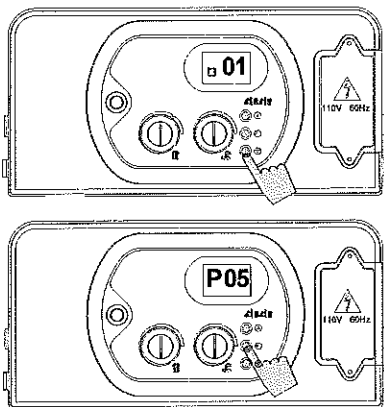

6. Use buttons '+' and '-' to modify the value of the parameter:  
 00 = off  
 01 = on (2 second burner delay upon D.H.W. call)
7. Press and release button 'S' to confirm. The parameter number (5) will appear on the display.
8. Switch off the appliance and switch it back on again to render the new parameter operative.

**PARAMETER 6 – CENTRAL HEATING TIMER**

**Electronically timed heating differential**

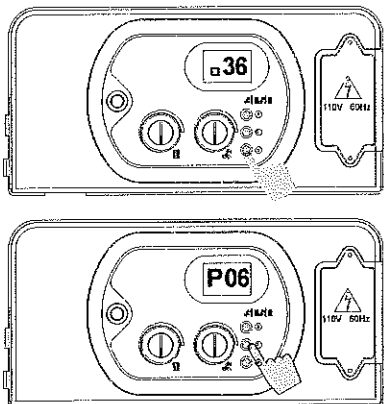

6. Use buttons '+' and '-' to modify the value of the parameter within the prescribed limits  
 00 = 0 x 5 sec = 0 sec  
 90 = 90 x 5 sec = 450 sec (7.5 min)  
 The default value is 36 = 180 sec = 3 min
7. Press and release button 'S' to confirm. The parameter number (6) will appear on the display.
8. Switch off the appliance and switch it back on again to render the new parameter operative.

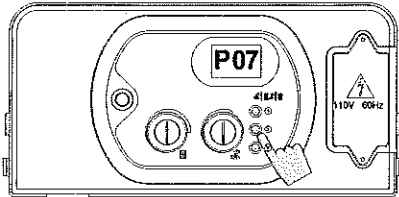
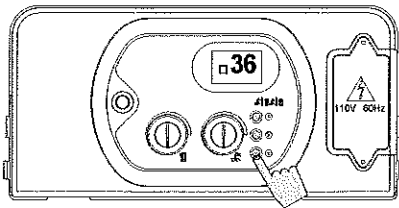

**PARAMETER 7 – CENTRAL HEATING PUMP OVERRUN TIMER**

6. Use buttons '+' and '-' to modify the value of the parameter within the prescribed limits

00 = 0 x 5 sec = 0 sec

90 = 90 x 5 sec = 450 sec (7.5 min)

The default value is 36 = 180 sec = 3 min

7. Press and release button 'S' to confirm. The parameter number (7) will appear on the display.

8. Switch off the appliance and switch it back on again to render the new parameter operative.

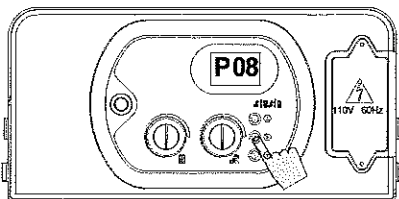
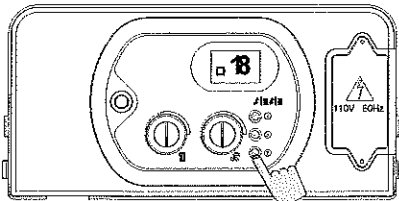

**PARAMETER 8 – D.H.W PUMP OVERRUN TIMER**

6. Use buttons '+' and '-' to modify the value of the parameter within the prescribed limits

00 = 0 x 5 sec = 0 sec

90 = 90 x 5 sec = 450 sec (7.5 min)

The default value is 18 = 90 sec = 1.5 min

7. Press and release button 'S' to confirm. The parameter number (8) will appear on the display.

8. Switch off the appliance and switch it back on again to render the new parameter operative.

**PARAMETER NO.9**

*Not applicable for premix burner (only for atmospheric burner)*

**PARAMETER NO.10**

*Not applicable for premix burner (only for atmospheric burner)*

**PARAMETER NO.11**

*Not applicable for premix burner (only for atmospheric burner)*

**PARAMETER NO.12**

*Not applicable for premix burner (only for atmospheric burner)*

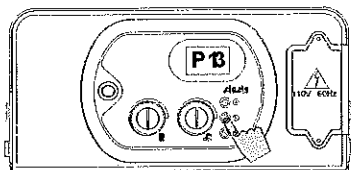
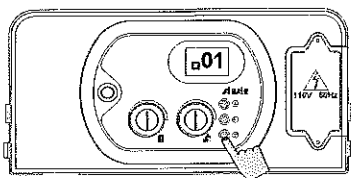

**PARAMETER 13 – D.H.W PRIORITY**

6. Use buttons '+' and '-' to modify the value of the parameter:  
 00 = off  
 01 = On (Keeps 3-way valve in D.H.W position for 2 minutes after a call for D.H.W. ends).
7. Press and release button 'S' to confirm. The parameter number (13) will appear on the display.
8. Switch off the appliance and switch it back on again to render the new parameter operative.

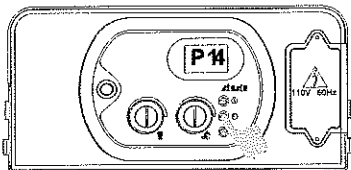
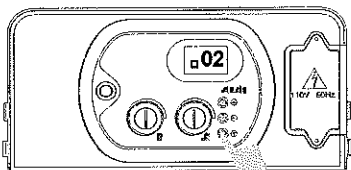

**PARAMETER 14 – TYPE OF BURNER**

6. Use buttons '+' or '-' to modify the value of the parameter:  
 00 = boiler with atmospheric burner,  
 01 = PCH 18, PCH18/B or PCI 18/8  
**02 = PCH 34/B, PCI 34/20 or PCC 34**  
 03 = PCH 50/B
7. Press and release button 'S' to confirm. The parameter number (14) will appear on the display.
8. Switch off the appliance and switch it back on again to render the new parameter operative.

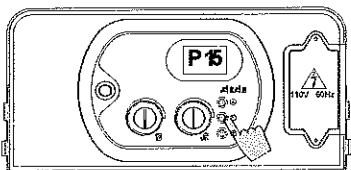
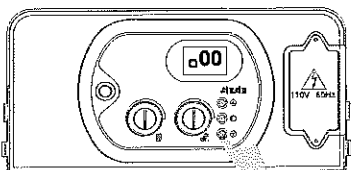

**PARAMETER 15 – ZONED SYSTEM – NOT APPLICABLE**

**KEEP SET TO '00' – "OFF"**

If set to '01' the combination water heater will become a temperature maintaining unit and run constantly up to temperature limit.

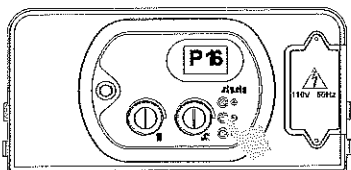
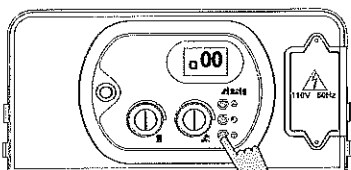

**PARAMETER 16 – TELEPHONE CONTROL – NOT APPLICABLE**

**KEEP SET TO '00' – "OFF"**

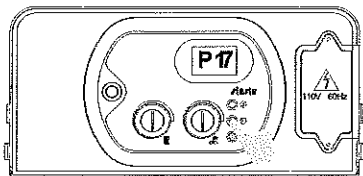
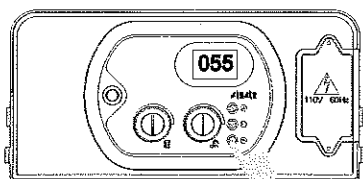

**PARAMETER 17 – MINIMUM FAN SPEED SETTING**

6. Use buttons '+' o '-' to modify the value of the parameter:  
max = value of parameter 18

The default value is :  
- 55 Hz for Natural Gas;  
- 52 Hz for L.P.G.;

7. Press and release button 'S' to confirm. The parameter number (17) will appear in the display.

8. Switch off the appliance and switch it back on again to render the new parameter operative.

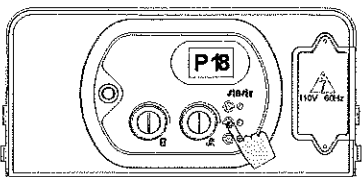
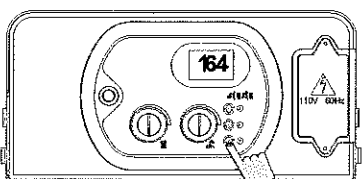

**PARAMETER 18 – MAXIMUM FAN SPEED SETTING**

6. Use buttons '+' o '-' to modify the value of the parameter:  
min = value of parameter 17.

The default value is:  
- 164 Hz for Natural Gas;  
- 155 Hz for L.P.G.;

7. Press and release button 'S' to confirm. The parameter number (18) will appear in the display.

8. Switch off the appliance and switch it back on again to render the new parameter operative.

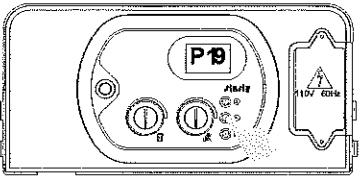
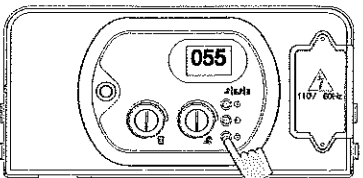

**PARAMETER 19 – MINIMUM FAN SPEED SETTING**

**CENTRAL HEATING MODE**

6. Use buttons '+' o '-' to modify the value of the parameter:  
max = value of parameter 20.

The default value is:  
- 55 Hz for Natural Gas;  
- 52 Hz for L.P.G.;

7. Press and release button 'S' to confirm. The parameter number (19) will appear in the display.

8. Switch off the appliance and switch it back on again to render the new parameter operative.

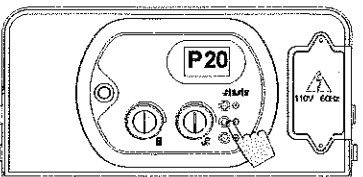
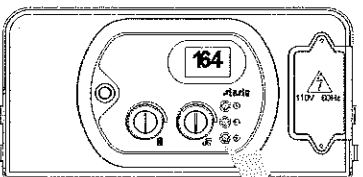

**PARAMETER 20 – MAXIMUM FAN SPEED SETTING CENTRAL HEATING MODE**

6. Use buttons '+' o '-' to modify the value of the parameter:  
min = value of parameter 19

The default value is:  
- 164 Hz for Natural Gas;  
- 155 Hz for L.P.G.;

7. Press and release button 'S' to confirm. The parameter number (20) will appear in the display.

8. Switch off the appliance and switch it back on again to render the new parameter operative.

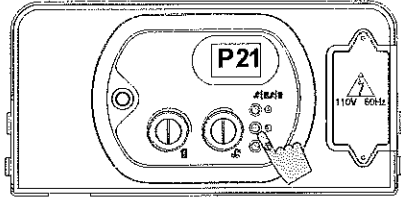
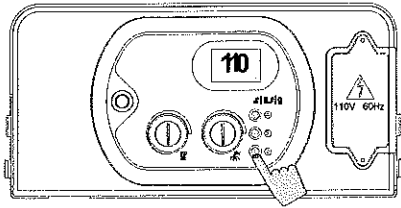

### PARAMETER 21 – IGNITION SEQUENCE SETTING

#### IGNITION POINT IN HZ

6. Use buttons '+' or '-' to modify the value of the parameter between: min = value of parameter 17; max = value of parameter 18.

The default value is:

- 110 Hz for Natural Gas;
- 130 Hz for L.P.G.;

7. Press and release button 'S' to confirm. The parameter number (21) will appear in the display.

8. Switch off the appliance and switch it back on again to render the new parameter operative.

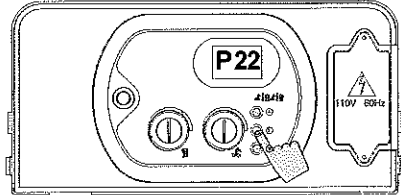
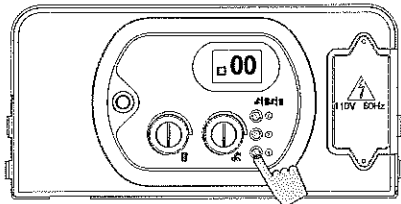

### PARAMETER 22 – FAN FREQUENCY VALUE DISPLAY

6. Use buttons '+' or '-' to modify the value of the parameter:

- 00 = Off
- 01 = On

If parameter value 01 is selected, during the appliance operation, the display will show the fan frequency value for 10 min.

7. Press and release button 'S' to confirm. The parameter number (22) will appear in the display.

8. Switch off the appliance and switch it back on again to render the new parameter operative.

### 5.3 Gas data

#### Technical data tables

Table no.1 - CO <sub>2</sub> Values	
Gas type	CO <sub>2</sub> %
Natural Gas – Gas A	9.18
Liquid Propane Gas – Gas E	10.3

Table no.2 - Frequency		
Gas type	Minimum (Hz)	Maximum (Hz)
Natural Gas – Gas A	55	164
Liquid Propane Gas – Gas E	52	155

		NATURAL GAS – GAS A	LIQUID PROPANE GAS – GAS E
Lower Wobble Index (59F; 14.5 psi)	MJ/Nm <sup>3</sup>	45.67	70.69
Nominal supply gas pressure	"WC	7	11

#### Heating Power (kW) – Fan frequency (Hz) diagram

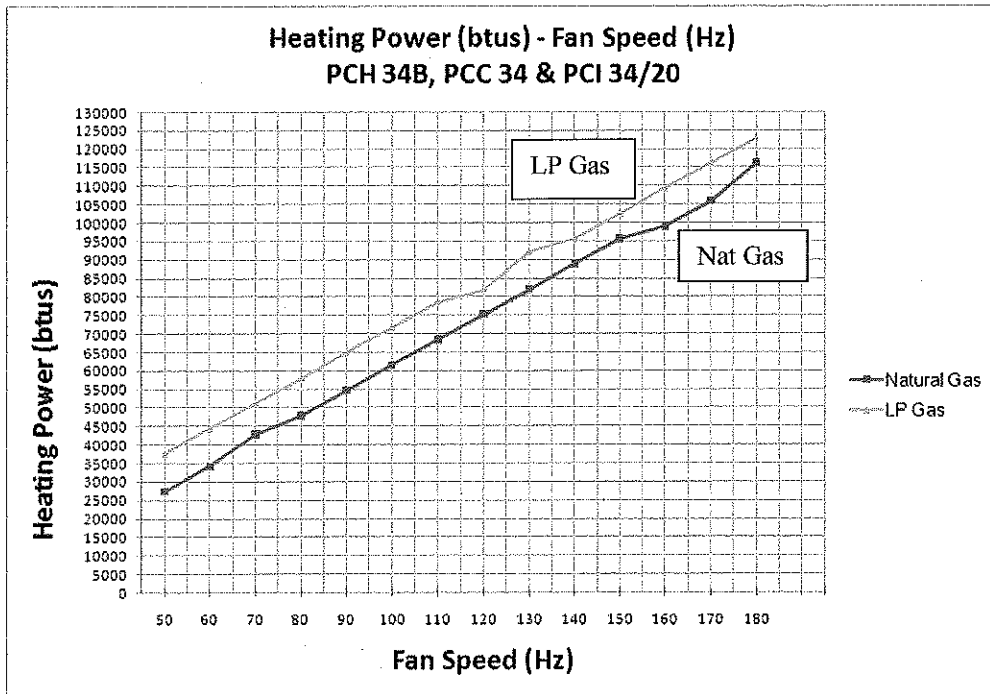



## 5.4 Converting the boiler to a different gas type

- ⚠ The conversion of this combination water heater from burning natural gas to LPG, or vice versa, must be carried out exclusively by professionally qualified personnel, registered in accordance with current legislation and authorized by Pensotti LLC. It is necessary to use a properly calibrated, electronic combustion analyzer.
- ⚠ Check that the gas supply pipe is suitable for the new fuel type.

### Pensotti Solenne Series Gas Boiler Conversion Instructions



1. Place the On/Off switch in the off position.



2. Activate the On/Off switch while keeping buttons '+' and '-' pressed. Wait for "P 00" to appear on the display.

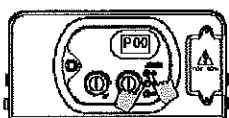

3. Release buttons '+' and '-'.

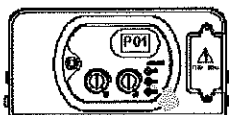

4. Keep buttons 'S' pressed and use button '+' or '-' to select a parameter to modify.

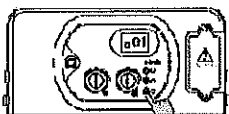

5. Release button 'S', then re-press and release it. The display will indicate the value of the parameter to modify.

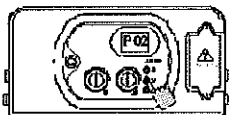

#### PARAMETER 2 – GAS SUPPLY

6. Use buttons '+' or '-' to modify the value of the parameter:

"00" = natural gas

"01" = lp gas

7. Press and release button 'S' to confirm. The parameter "P02" will appear on the display.

8. Switch off the appliance and switch it back on again to render the new parameter operative.

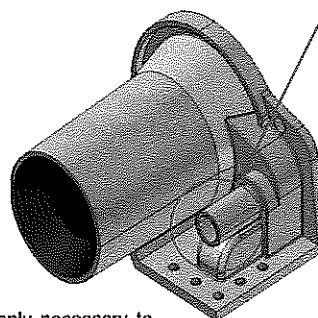
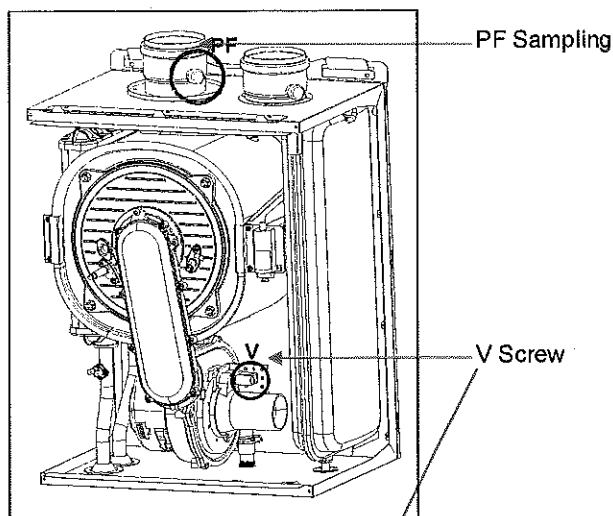

\*When Converting model numbers PCC 34, PCH 34B, PCI 34/20 and PCH 50B it is only necessary to change Parameter "P02". If converting models numbers PCH 18, PCH 18B or PCI 18/8 it is necessary to change Perimeters 2, 17, 18, 19, 20 and 21 to the values found in the corresponding installation manuals.

9. Turn the appliance off using the power button.
10. As a preliminary adjustment, using a 4mm allen wrench or properly sized slotted screwdriver, turn the V screw clockwise 4 turns (PCH 18, PCH 18B & PCI 18/8 – 2 ½ to 3 turns). Leave the wrench or screwdriver in the V screw to make the final adjustment.
11. Turn on all available HEAT zones. Turn the appliance back on and set the mode selection to HEAT ONLY position by pressing the '+' button.
12. After the boiler fires, press and hold the center button, 'S' for a few seconds until you see '07' appear on the screen/ This will hold the boiler in high fire for 15 minutes.
13. Unscrew the white test plug and insert an analyzer in the exhaust sampling point 'PF' to check the CO2 value. Make sure the value complies with the boiler installed.
14. If the CO2 value does not correspond to the specified value, adjust the V screw on the venturi clockwise to reduce the CO2 value or counter-clockwise to increase it. Be careful not to block the boiler air/fuel venturi with your hand as you adjust the V screw.
15. Once the V screw adjustment is complete, remove the allen wrench or screwdriver. Turn the power button off and then back on. The boiler control is now back in normal operation mode. (If this step is ignored the control will revert back to normal operation after the 15 minute period expires).
16. Select the proper operation mode and temperatures as required.

## 6. MAINTENANCE (authorized personnel)

### 6.1 General Warnings

All maintenance operations must be carried out by professionally qualified personnel, authorized by PENSOTTI

The frequency of water heater maintenance is recommended to be carried out once a year.

In order to guarantee the long life of the appliance and in accordance with the current gas safety regulations, only use original replacement parts

Before carrying out any type of maintenance operation, disconnect the appliance from the electrical supply and shut off the gas valve.

**Warranty will not be offered if recommended maintenance is not followed.**

**Keep appliance area clear and free from combustible material, gasoline and other flammable vapors and liquids.**

**In order to safeguard all waterside components the supplied Fernox Commissioning Kit must be used in its entirety.**

### 6.2 Maintenance

**Periodic examination of the entire venting system is recommended. Make sure all the venting connections/joints are tight and in good condition where visible.**

Clean the burner cylinder using a non-metal brush and without damaging the ceramic fiber.

Clean the heat exchanger using a recommended detergent from PENSOTTI for the stainless steel. Do not wet the ceramic fiber coating.

**Visually inspect the burner flame. The flame must burn with a clear blue, stable flame. If the burner flame appearance is not satisfactory or debris is visible on the burners, remove and clean with a vacuum cleaner.**

All electric motors are permanently lubricated and do not need oiling. Remove the combustion air blower and clean wheel and housing with soft brush or vacuum.

Verify proper operation after any servicing.

Wipe the outside surface with a wet cloth; then dry the surface. Use a neutral detergent to clean any stains.

**Vent termination should be inspected for blockage during maintenance checks.**

Check for blockage at the drain pipe and condensate trap.

Clean condensate trap and check for correct level of water.

Check for water leaks from the equipment and piping.

**Warranty will not be offered if recommended maintenance is not followed.**

### 6.3 Water heater inspection

In order to ensure that the water heater operates efficiently and safely, it is recommended that the appliance is inspected by a suitably competent technician at least once a year.

The following operations should be carried out annually:

- Check the condition of the gas seals and replace where necessary.
- Check the condition of the water seals and replace where necessary.
- Visually inspect the condition of the combustion chamber and flame.
- Check that the combustion is correctly regulated and if necessary proceed in line with section "Commissioning the water heater".
- Remove and clean any oxidation from the burner.

**If a relief valve discharges periodically, this may be due to thermal expansion in a closed water supply system. Contact a qualified plumber to correct this situation. DO NOT PLUG THE RELIEF VALVE.**

- Check that the seal of the room-sealed chamber is undamaged and positioned correctly.
- Check the primary heat exchanger and clean if necessary.
- Check the maximum and minimum modulation pressures and the modulation itself.
- Check the condition and operation of the ignition and gas safety systems. If necessary, remove and clean the scaling from the ignition and flame detection electrodes, paying particular attention to replace them at the correct distance from the burner.
- Check the heating safety systems: temperature limit safety thermostat, pressure limit safety device.
- Check the pre-fill pressure of the expansion tank (see expansion tank rating plate).
- For safety reasons, periodically check the integrity and operation of the exhaust system.
- Check that the connection to the mains electricity supply complies with that reported in the water heater's instruction manual.
- Check the electrical connections inside the control panel.
- Check the D.H.W flow rate and temperature.
- Check that the condensate drain system is working correctly, including any parts of the system outside the water heater such as condensate collection devices along the length of the exhaust vent and/or any acid neutralizing devices.
- Check that the condensate flows freely and that there are no exhaust fumes present within the appliance.

**Warranty will not be offered if recommended maintenance is not followed.**

## 6.4 Accessing the water heater

All maintenance operations require one or more of the appliance casing panels to be removed.

The side panels can only be removed after the front panel has been removed.

### Front panel:

Remove the fixing screws at the lower edge of the front panel.

- Grasp the lower part of the panel and pull it outwards (see fig. 1) and then up (see fig. 2).

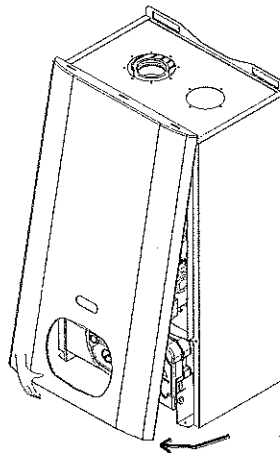

Fig. 1

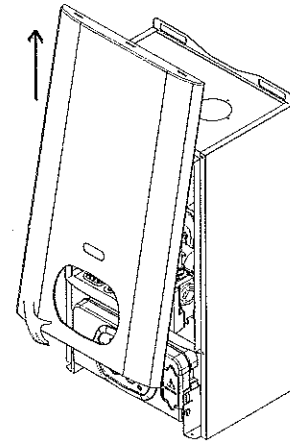

Fig. 2

### Left and right side panel:

- Remove the fixing screws at the front and lower edge of the side panel to remove.
- Grasp the bottom of the panel, move it sideways and then upwards to remove it.

To access the electrical connections of the control panel, proceed as follows:

- Remove the front panel (see fig. 1 and fig. 2).
- Grasp the left and right control panel support brackets (see fig. 5) and pull them outwards, at the same time rotating the panel downwards.
- Unscrew the four fixing screws (see fig. 6) and remove the panel back piece.

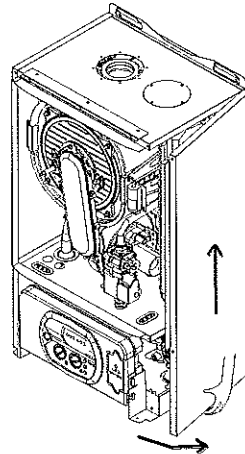

Fig. 3

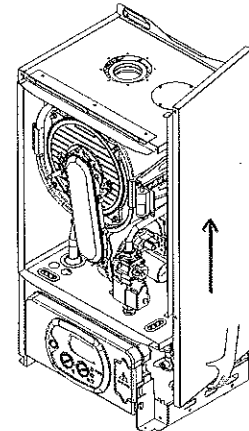

Fig. 4

## 6.5 Flushing out the primary side

Fill the water heater as per the filling instructions.

Using a drain off cock on the lowest point of the system allow the water to drain from the system and water heater.

In order to flush the system correctly, turn off all radiators or fan coils. Open the filling loop and drain cock simultaneously and allow the water to flow through the water heater.

Open each individual radiator or fan coil, allowing water to flow through. Then turn that radiator or fan coil off and repeat for all radiators or fan coil on the system.

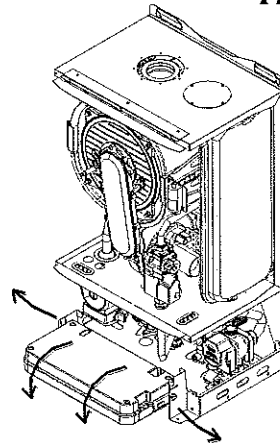

Fig. 5

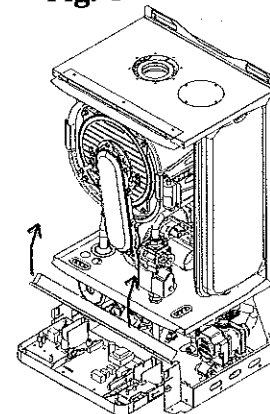

Fig. 6

Turn off the filling loop and close the drain cock open all radiators and open the filling to fill the system. Continue to fill the system until the pressure gauge reads in the Green section of the gauge (14.5 psi (1 bar))

**In order to safeguard all waterside components the supplied Fernox Commissioning Kit must be used in its entirety.**

## 6.6 Draining the central heating system

If the need arises to drain the system, this can be done as follows:

- Switch the system to "HEAT" mode and ignite the boiler.
- Switch off the power supply to the water heater.
- Wait for the appliance to cool down.
- Connect a hosepipe to the system drain point **R** and locate the other end of the hose in a suitable drainage system.
- Open the system drain valve (fig. 1).
- Open the manual air vent located on the primary heat exchanger.
- Open the air vents on the radiators, starting with the highest and moving down the system to the lowest.
- When the system has been drained, close the radiator air vents and the drain valve.
- **If only the water heater needs to be drained, close the flow/return isolating valves on the heating circuit and open the drain valve R located at the bottom of the water heater on the pump manifold (see fig. 1);**

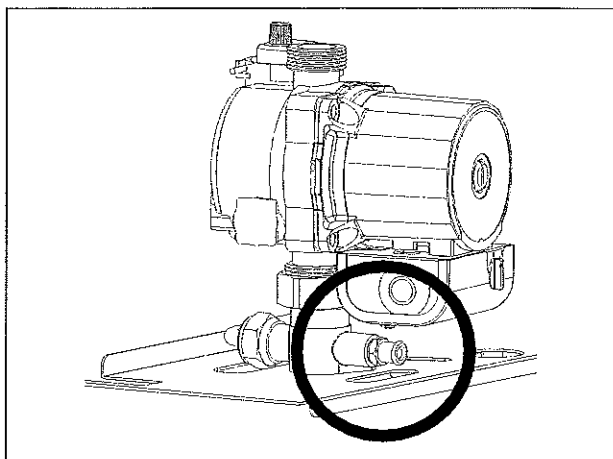

### Draining the domestic hot water system

If there is a danger of freezing, the domestic hot water system should be drained. This can be done as follows:

- Close the main water supply valve.
- Joint the water draining pipe and open the cylinder draining tap (see fig. 2)
- Open all the hot and cold water taps.
- **On completion, close all the previously opened taps.**

### Freeze Protection

- ⚠ **Glycol must not be used in Domestic Hot Water applications.**

#### System winterization (non-operative system)

Because it may be impossible to completely drain the combination water heaters heating circuit, D.H.W circuit and distribution system. Pensotti recommends the introduction of the proper type antifreeze to protect these systems from freezing damage. **Glycol must not be used in Domestic Hot Water applications.**

#### System winterization (operating system)

Pensotti combination water heaters are certified for indoor use ONLY. Proper precautions for freeze protection are recommended for combination water heaters and associated piping in areas where the danger of freezing exists. Do not use automotive antifreeze. Pensotti recommends the use of inhibited glycol concentrations between 20-35% glycol. Glycol products must be maintained properly so they do not become inactive or corrosive, consult glycol specifications for more information.

## 6.7 Maintenance operations

**⚠** Before carrying out any cleaning or part replacement operations, **ALWAYS** turn off the **ELECTRICITY**, **WATER** and **GAS** supplies to the combination water heater.

Pensotti LLC will not be held responsible for damage to any of the water heater's components caused by non-compliance with this instruction.

For all maintenance operations requiring removal of the water heater casing, refer to the procedures described in paragraph 6.4 "Accessing the water heater".

Cleaning the main exchanger module and combustion unit (fig. 1)

- Disconnect the electrical connections of the electric fan.
- Disconnect the joint and remove the pipe linking the gas valve to the injector unit (venturi).
- Disconnect the joint and remove the gas feed pipe from the gas valve.
- Un-plug the ignition electrode and flame detection wires from the ignition control unit.
- Unscrew the ring-nut at the bottom of the room-sealed chamber and remove the gas valve.
- Unscrew the nuts securing the burner unit (consisting of a fan, manifold and burner) to the primary heat exchanger.
- Remove the burner unit, paying particular attention not to remove the ceramic fibre protection from the bottom of the heat exchanger.
- Check that the burner is not affected by deposits, scaling or excessive oxidation. Check that all the holes in the burner are free.
- Clean the electrodes carefully without altering their positions with respect to the burner.
- Clean the burner cylinder using a non-metal brush and without damaging the ceramic fibre.
- Check the integrity of the gasket on the cover of the burner.
- Clean the heat exchanger using a household detergent for stainless steel, distributing the product on the spirals of the exchanger using a brush. Do not wet the ceramic fibre coating. Wait a few minutes then remove the deposits using a non-metal brush. Then remove the residues under running water.
- Remove the pipe clip, remove the condensate drainpipe and clean under running water.
- Unscrew the joint to the condensate trap, remove the trap and wash under running water.
- With the cleaning completed, re-assemble the components following the above procedure in reverse order.
- Finally, check the appliance to make sure that all gas and exhaust joints are tight.

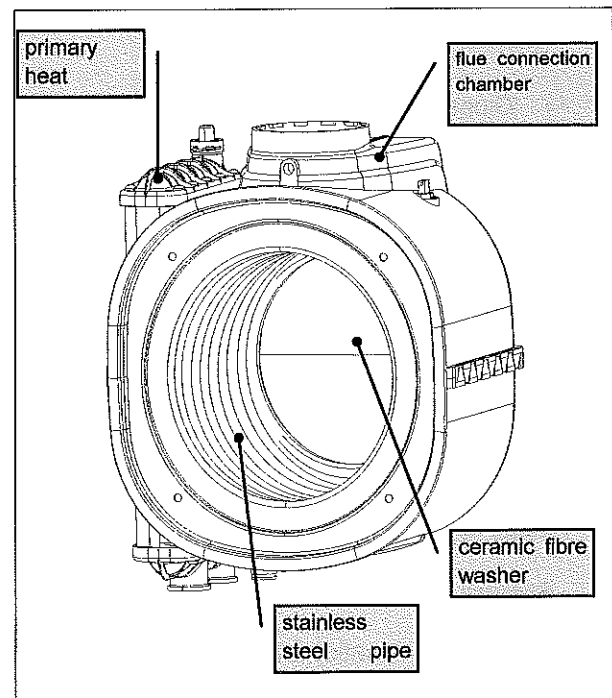
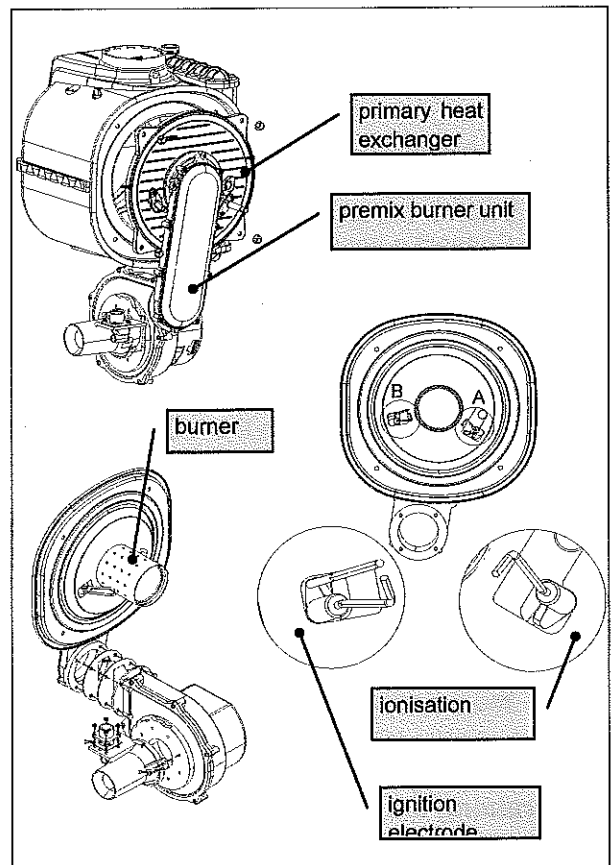

Part replacement:

**Ignition and/or flame detection electrodes**

(see fig. 2)

- **Un-Plug the electrode wires;**
- Slacken the fixing screws;
- Remove the electrodes. When fitting the new ones, check that the seals are not damaged. Replace if necessary;
- Reconnect the wires and re-assemble the components following the above procedure in reverse order;
- Switch on the power supply and restart the appliance;
  - △ *If the appliance does not restart, check the positions of the electrodes (especially the ignition electrode). Make sure that original position and distances between the electrodes and the burner are respected to avoid a malfunction).*

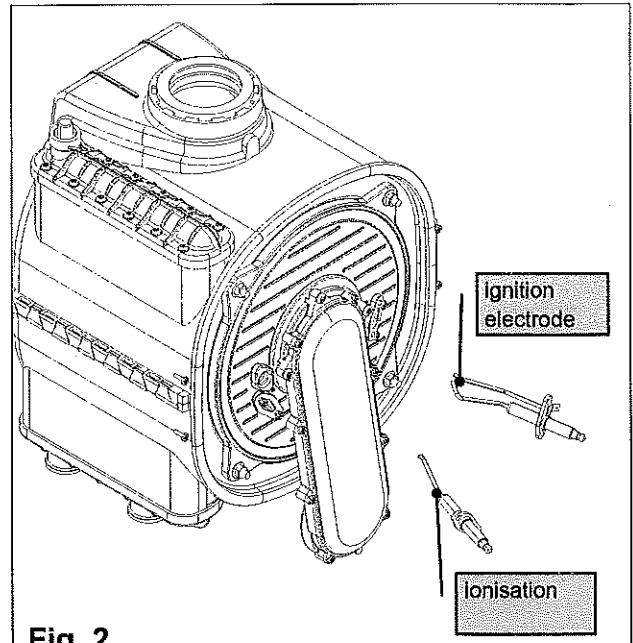

**Fig. 2**

**POSITIONING THE IGNITION ELECTRODE AND THE IONISATION ELECTRODE (mm)**

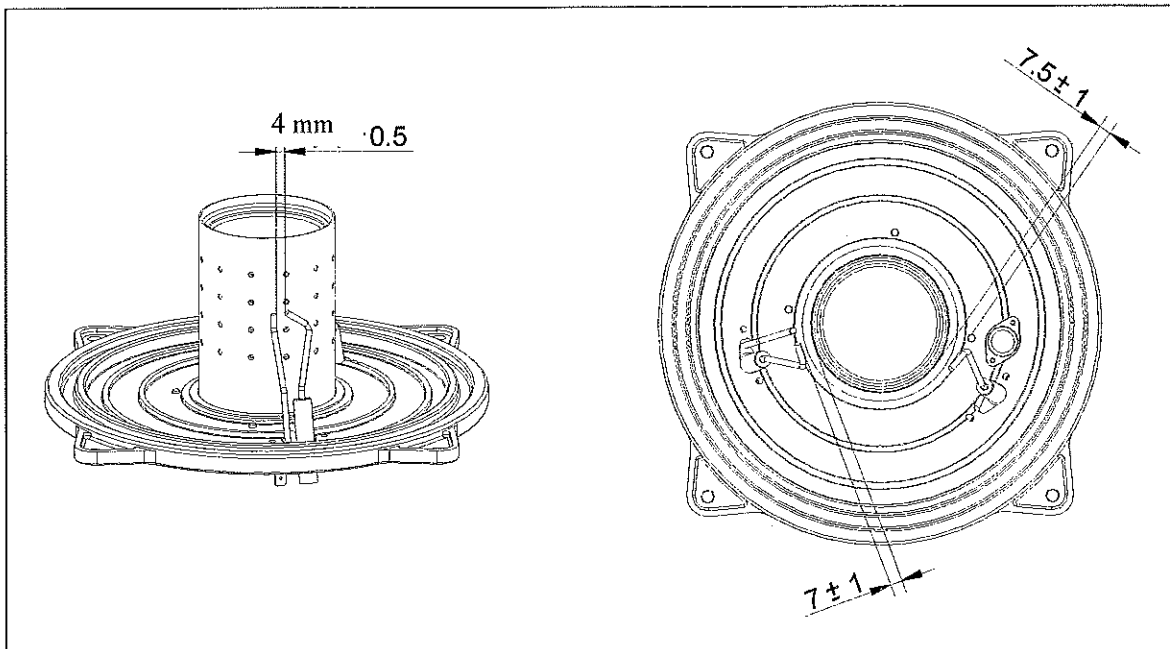

**Safety thermostat (see fig. 1)**

- **Disconnect the connecting wire;**
- Unscrew the fixing screws and remove the thermostat;
- Replace the thermostat and re-assemble the components following the above procedure in reverse order;
- Switch on the electricity, water and gas supplies and restart the appliance.

**Heating sensor (see fig. 1)**

- **Un-Plug the connecting wire;**
- Replace the sensor and re-assemble the components following the above procedure in reverse order;
- Switch on the electricity, water and gas supplies, open the shut-off valves and fill the central heating circuit. Then restart the appliance, remembering to discharge any air that may be trapped in the system;

**Gas valve (see fig. 2)**

- **Unscrew the screws connecting the gas valve to the venturi.**
- Disconnect the gas feed pipe and valve ring-nut at the bottom of the room-sealed chamber.
- Remove the flanged elbow coupling of the existing valve and fit it to the new valve; also fit a new cork washer and a new fiber gasket.
- Replace the gas valve and re-assemble the components following the above procedure in reverse order.
- Replace all the gas seals.
- Fully tighten the gas connections.
- Switch on the electricity, water and gas supplies and check for any gas leaks using a soapy solution or leak detector spray;

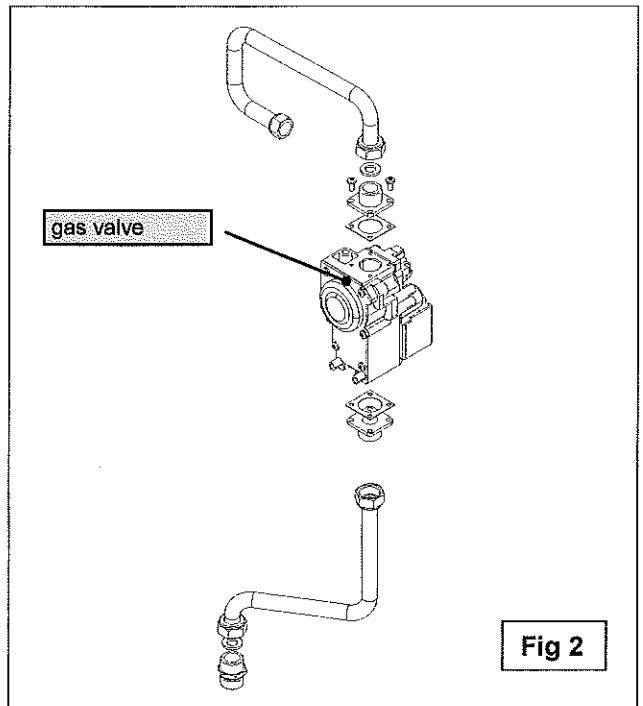
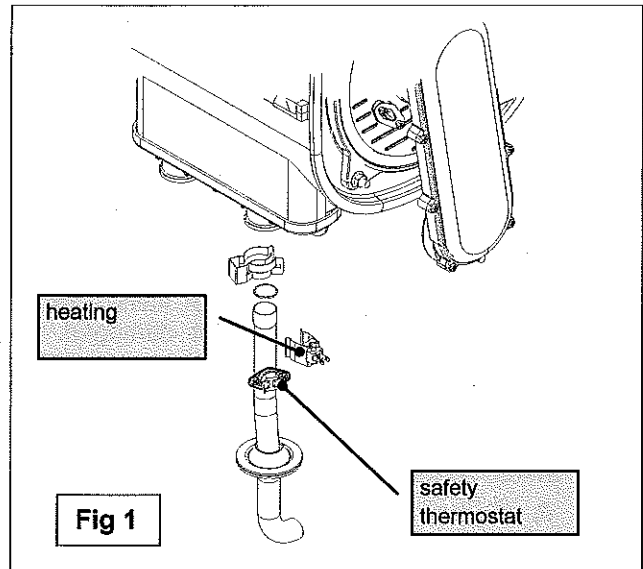



**Electric fan** (see fig. 1)

- **Remove and dismantle the entire burner unit** (see *“Cleaning the burner unit”*).
- Use an 8 mm spanner to unscrew the four nuts securing the electric fan to the gas manifold and then remove the electric fan, noting the positions of the washer.
- Remove the air intake duct, unscrew the two fixing screws from the venturi and remove the electric fan, paying particular attention not to damage the cork gasket.
- Replace the electric fan and re-assemble the components following the above procedure in reverse order.
- Switch on the electricity, water and gas supplies and check the soundness of the joint by measuring the CO<sub>2</sub> levels; using an electronic combustion analyzer.

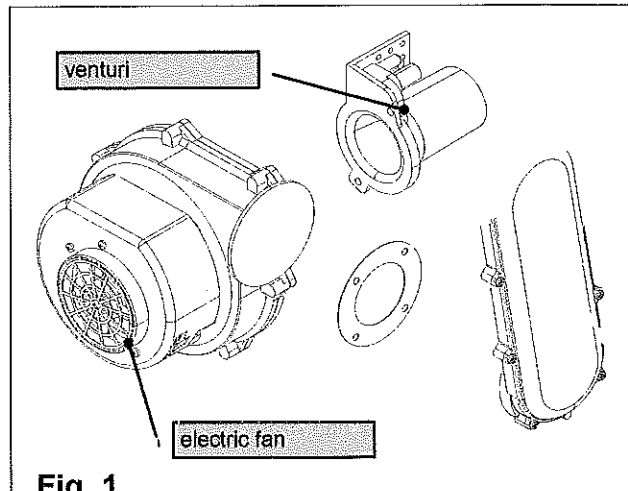

**Fig. 1**

**Circulating pump** (motor body) (see fig. 2)

- Close the shut-off valves and drain the central heating circuit of the water heater;
- Use a 5 mm Allen key to unscrew the four screws securing the motor body to the impeller body;
- Remove the motor body and check the condition of the washer. If necessary, replace the washer;
- Replace the circulation pump or cartridge only and re-assemble the components following the above procedure in reverse order;
- Switch on the electricity, water and gas supplies and fill the system with water. Check for any leaks from the joints and bleed off all air from the circuit. Restart the water heater.

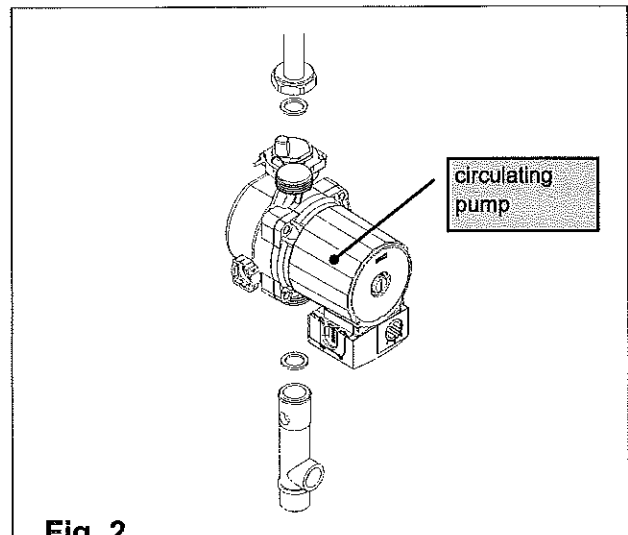

**Fig. 2**

**Diverter valve (see fig. 1)**

**Replacing the motor**

- Unscrew the fixing screws securing the transparent cover of the diverter valve and remove the cover;
- Unscrew the two motor fixing screws and disconnect the wires;
- Replace the motor and re-assemble the components following the above procedure in reverse order;
- Replace the motor and re-assemble the components following the above procedure in reverse order;

**Replacing the diverter valve**

- Close the shut-off valves and drain the central heating circuit of the water heater;
- Disconnect the joints securing the valve to the pipes;
- Replace the valve body and re-assemble the components following the above procedure in reverse order;
- Switch on the electricity, water and gas supplies and fill the system with water. Check for any leaks from the joints and bleed off any air from the circuit. Restart the water heater.

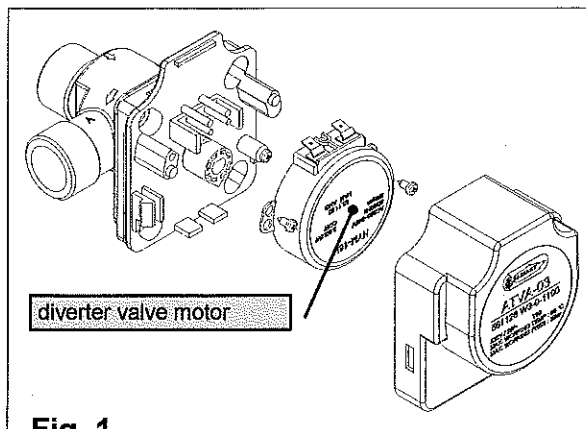

**Fig. 1**

**Modulating circuit board (see fig. 2-3)**

- **Open the control panel (see 6.4 "Accessing the boiler");**
- Disconnect all the connectors, remove the regulating knobs, unscrew the four fixing screws and remove the modulation circuit board;
- Replace the circuit board and re-assemble the components following the above procedure in reverse order;
- Switch on the electricity, water and gas supplies and regulate the water heater (see 5.3 "Gas data");

⚠ *Replacement modulating circuit boards must be programmed to the correct parameters before starting the appliance. Refer to section 5.1 parameters table.*

**Electric fan circuit board (see figs. 2-3)**

- **Open the control panel (see 6.4 "Accessing the boiler");**
- Disconnect the two connectors from the circuit board, unscrew the two fixing screws and remove the board;
- Replace the circuit board and re-assemble the components following the above procedure in reverse order;
- Switch on the electricity, water and gas supplies.

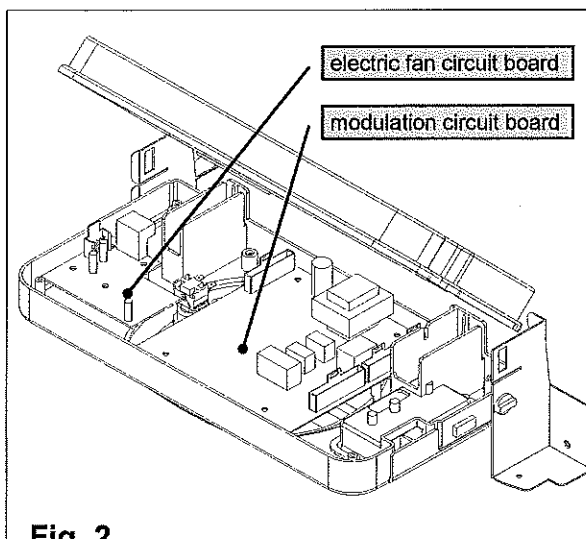

**Fig. 2**

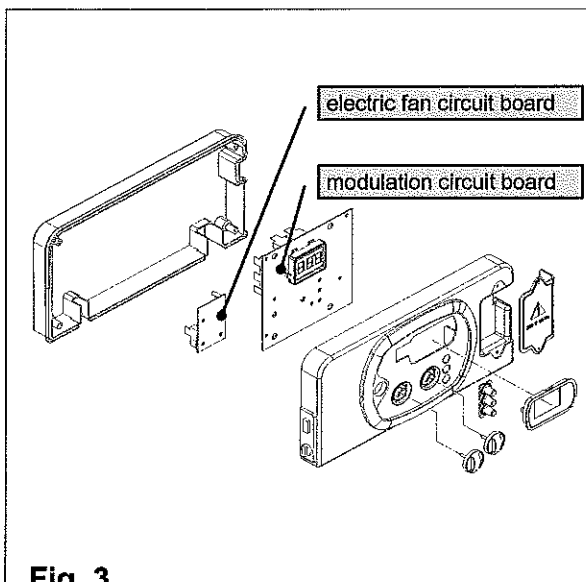

**Fig. 3**

**Primary heat exchanger** (see fig. 1)

- Close the shut-off valves and drain the central heating circuit of the water heater;
- **Switch off the power and gas supply to the water heater;**
- **Remove and dismantle the entire burner unit (see “Cleaning the condensation module and burner unit”);**
- **Remove the gas valve;**
- Remove the spring and then the condensate drainpipe;
- Remove the fixing springs and then the delivery and return pipes;
- Remove the support brackets and pull out the heat exchanger;
- Remove the regulation sensor from the old heat exchanger and refit it together with the two condensate drainpipes to the new one;
- Replace the heat exchanger and re-assemble the components following the above procedure in reverse order;
- Switch on the electricity, water and gas supplies and fill the system with water. Check for any leaks from the joints and bleed off any air from the circuit. Restart the water heater, making sure that there are no gas leaks;

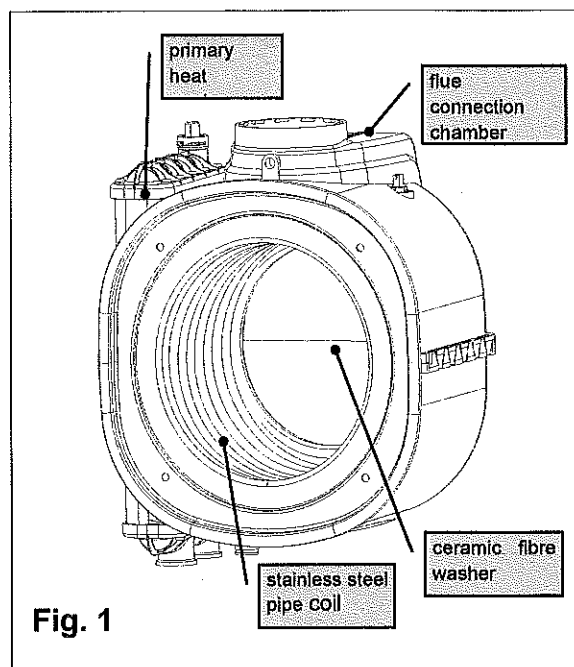

**Fig. 1**

**Expansion vessel** (see fig. 2)

- Close the shut-off valves and drain the central heating circuit of the water heater.
- Use a 19 mm spanner to unscrew the pipe coupling to the vessel.
- Unscrew the fixing screws and remove the upper mounting bracket. Remove the expansion vessel from the left side of the water heater.
- Replace the expansion vessel and re-assemble the components following the above procedure in reverse order.
- Switch on the electricity, water and gas supplies and fill the system with water. Check for any leaks from the joints and bleed off any air from the circuit;

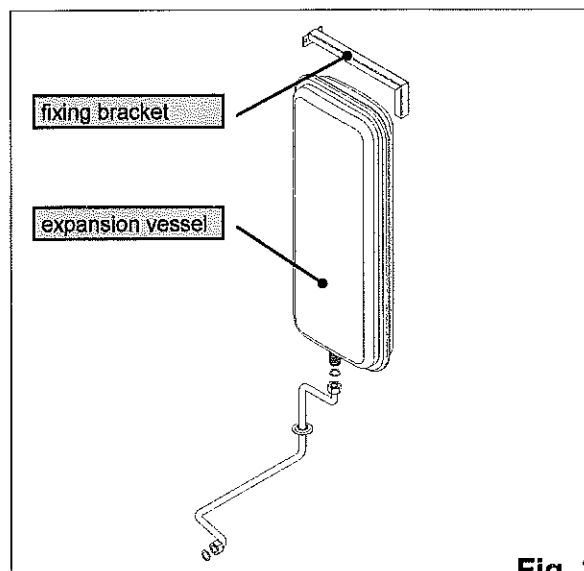

**Fig. 2**

6.8 Wiring diagrams

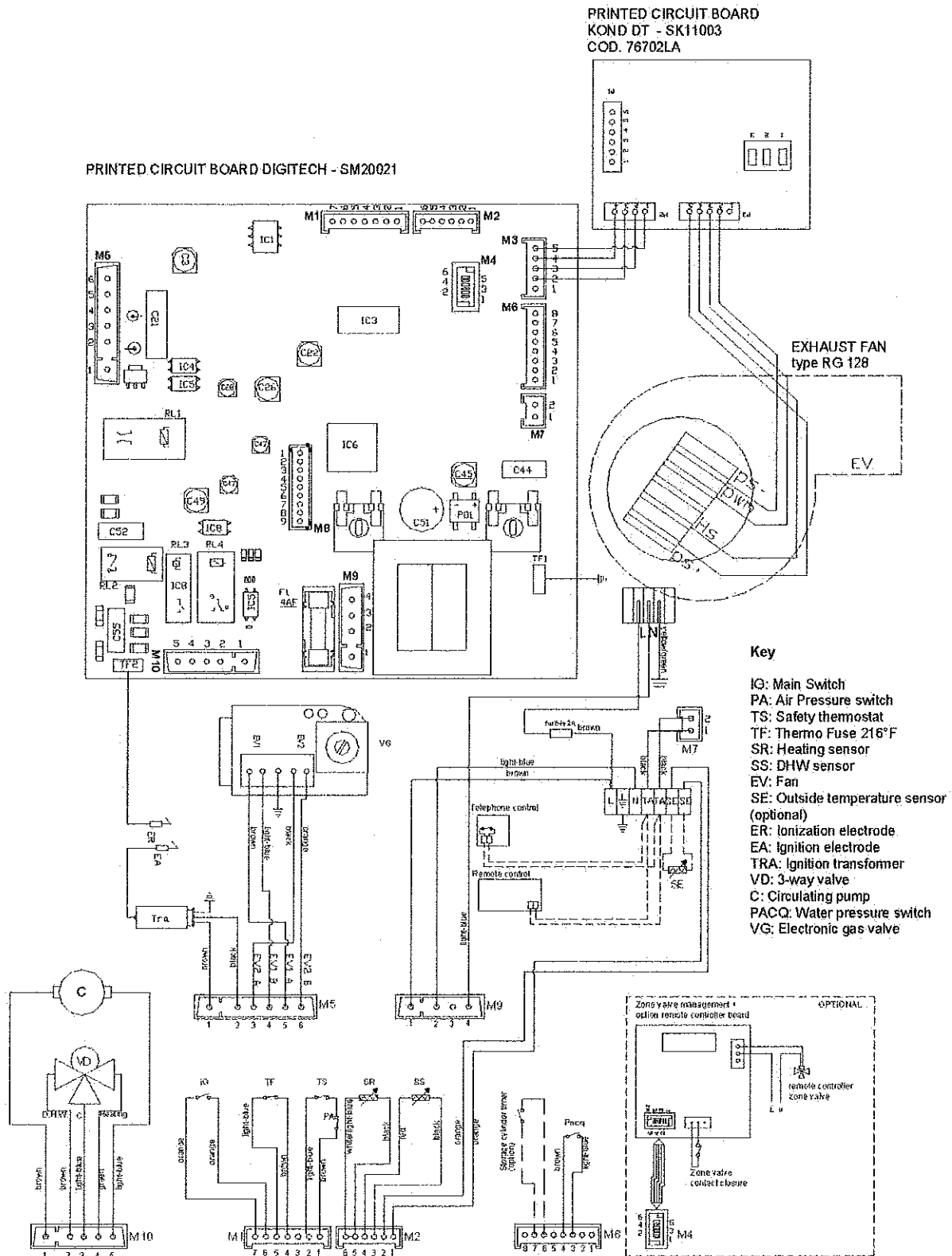

### Connecting the room thermostat (Option)

Connect the wires to the terminal board inside the instrument panel as follows:

**TA terminals are 24volt DC. Accordingly only a non-power stealing device can be installed to the these terminals.**

- a. switch off the power supply at the main switch.
- b. remove the front case panel of the water heater.
- c. slacken the screws and remove plate A (see fig.1).
- d. remove jumper TA -TA from the terminal board B;
- e. connect the room thermostat/end switch wires;

When the wires have been connected, place plate "A" back to position and then the front case panel.

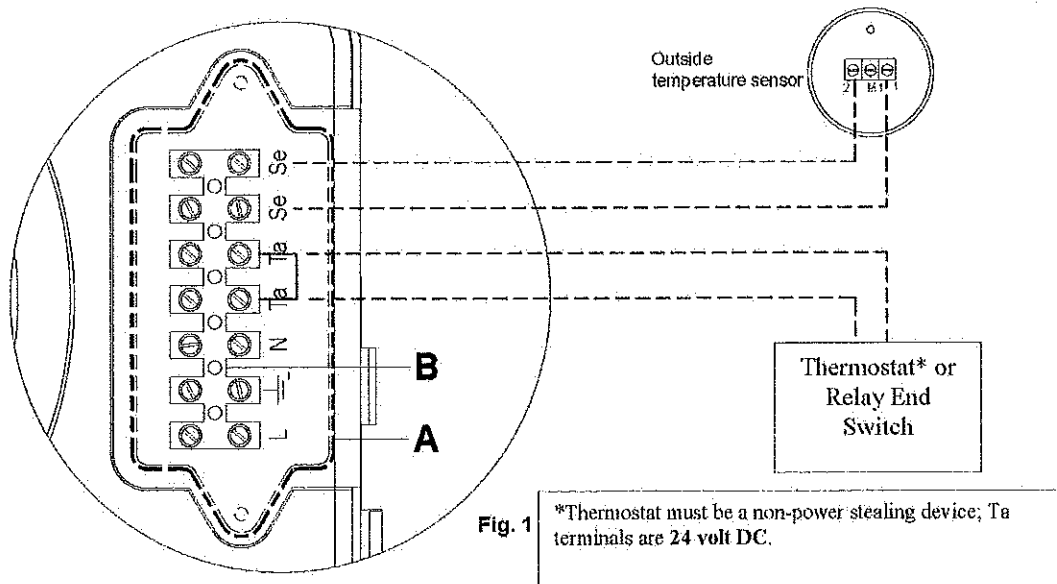

### Connecting the outside temperature sensor (Option)

Connect the wires to the terminal board inside the instrument panel as follows:

- a. switch off the power supply at the main switch.
- b. remove the front case panel of the water heater.
- c. slacken the screws and remove plate A (see fig.1).
- d. connect the outside temperature sensor on contacts marked as SE-SE on the terminal board B ;
- e. refer to the following page to set the reset curves.

When the wires have been connected, place plate "A" back to position and then the front case panel.

## Regulating the water temperature in accordance with the outdoor temperature

The outdoor sensor has to be connected directly to circuit board.

In case of outdoor temperature sensor installation, the climatic compensation curve is set using the central heating control knob. As the knob (see fig. 2) is rotated, the numbers corresponding to the curve shown in figure 1 are displayed

The factors governing the correction are reported in figure 1.

The selection of the compensation curve is determined by the maximum delivery temperature  $T_m$  and the minimum outdoor temperature  $T_e$ .

**N.B.** The y-axis values of the delivery temperature  $T_m$  refer to standard 176-86 °F appliances or 104-77 °F floor-mounted appliances. The type of appliance can be programmed using parameter 3 (see 5.1 "Parameter programming").

### OUTDOOR SENSOR DELIVERY TEMPERATURE CORRECTION AS A FUNCTION OF OUTSIDE TEMPERATURE WITH RESPECT TO THE POSITION OF THE HEATING TEMPERATURE CONTROL SET BY THE USER

**N.B.** The y-axis values of the delivery temperature  $T_m$  refer to standard 176-86 °F

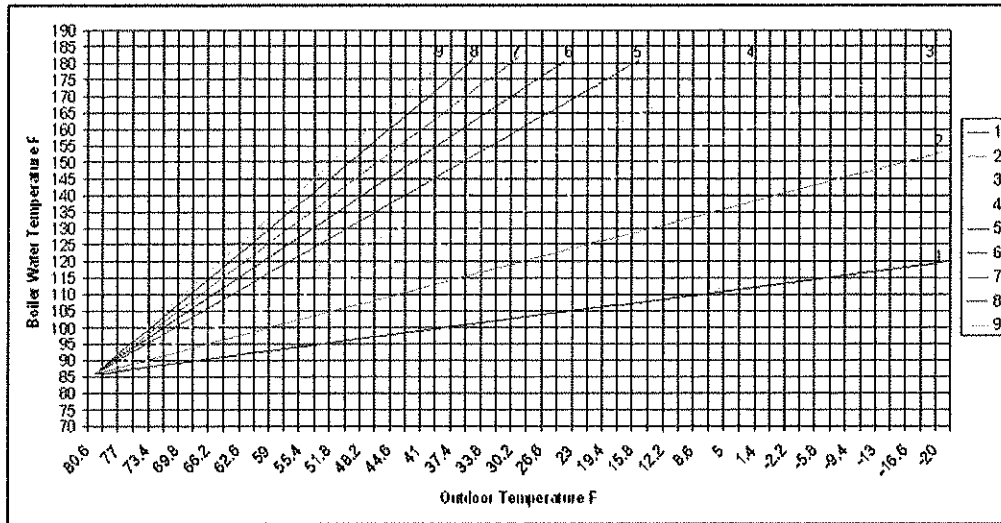

Fig. 1

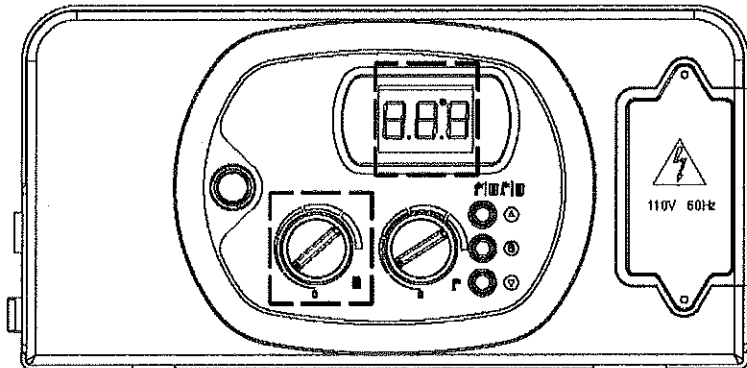

Fig. 2

## 6.9 Troubleshooting

ERROR CODE	PROBLEM	POSSIBLE CAUSE	REMEDY
E01	NO FLAME	<p>WITH NO IGNITION</p> <p>a. NO GAS. b. IGNITION ELECTRODE BROKEN OR GROUNDED. c. GAS VALVE MALFUNCTION d. MECHANICAL MINIMUM ADJUSTMENT (ON GAS VALVE) SET TOO LOW OR SLOW IGNITION ADJUSTMENT SET TOO LOW. e. GAS VALVE INLET PRESSURE TOO HIGH (FOR LPG WATER HEATERS ONLY);</p> <p>WITH IGNITION</p> <p>f. POWER SUPPLY LIVE AND NEUTRAL WIRES INVERTED. g. IONIZATION ELECTRODE MALFUNCTION. h. IONIZATION ELECTRODE CABLE DISCONNECTED.</p>	<p>WITH NO IGNITION</p> <p>a. CHECK MAINS SUPPLY. b. REPLACE PART. c. REPLACE PART d. REGULATE MECHANICAL MINIMUM OR SLOW IGNITION. e. CHECK THE MAXIMUM PRESSURE SETTING.</p> <p>WITH IGNITION</p> <p>f. CONNECT THE POWER SUPPLY WIRES CORRECTLY. g. REPLACE PART. h. CONNECT THE IONIZATION ELECTRODE WIRE.</p>
E02	SAFETY THERMOSTAT TRIPPED (203°F) / AIR PRESSURE SWITCH TRIPPED	<p>i. THERMOSTAT MALFUNCTION OR OUT OF CALIBRATION. j. THERMOSTAT CABLE DISCONNECTED.</p> <p>AIR PRESSURE SWITCH</p> <p>k. SWITCH OUT OF ORDER l. INLET OR OUTLET FLUE GAS DUCTS OBSTRUCTED m. SWITCH CABLE NOT STABLE</p>	<p>i. REPLACE PART.</p> <p>j. CHECK THE WIRING;</p> <p>AIR PRESSURE SWITCH</p> <p>k. REPLACE PART l. CHECK FLUE GAS DUCTS m. CHECK CABLE</p>
E03	FLUE SAFETY THERMOFUSE	<p>n. THERMOFUSE BROKEN; o. THERMOFUSE CABLE DISCONNECTED; p. THERMOFUSE LOCK OUT. (HIGH FLUE TEMPERATURE)</p>	<p>n. REPLACE PART; o. CHECK THE ELECTRICAL CONNECTION; p. RESTART AND CHECK THE THERMOFUSE</p>
H20	NO WATER IN THE SYSTEM	<p>q. INSUFFICIENT WATER PRESSURE IN THE SYSTEM (STOPS AT 4.5 PSI (0.3 BAR)). r. WATER PRESSURE SWITCH CABLE DISCONNECTED. s. WATER PRESSURE SWITCH MALFUNCTION.</p>	<p>q. FILL THE SYSTEM; r. CHECK THE WIRING; s. REPLACE PART;</p>
E05	HEATING SENSOR	<p>t. SENSOR MALFUNCTION OR OUT OF CALIBRATION (RESISTANCE VALUE 10 kOhms AT 77 °F). u. SENSOR CABLE DISCONNECTED OR WET.</p>	<p>t. REPLACE PART; u. CHECK THE ELECTRICAL CONNECTION;</p>
E06	D.H.W SENSOR	<p>v. SENSOR MALFUNCTION OR INCORRECT (RESISTANCE VALUE 10 kOhms AT 77 °F). w. SENSOR CABLE DISCONNECTED OR WET.</p>	<p>v. REPLACE PART; w. CHECK THE ELECTRICAL CONNECTION;</p>
E16	FAN	<p>x. BURNT FAN – BEFORE REPLACING FAN MOMENTARILY DISCONNECT POWER TO THE APPLIANCE THEN RECONNECT POWER. IF ERROR CODE CLEARS AND APPLIANCE OPERATES NORMAL DO NOT REPLACE THE FAN.</p>	<p>x. REPLACE PART</p>
E22	PARAMETER PROGRAMMING REQUEST	<p>y. LOSS OF MICROPROCESSOR MEMORY OR NEW PCB</p>	<p>y. REPROGRAM PARAMETERS;</p>
E35	FLAME DETECTION MALFUNCTION	<p>z. IONIZATION ELECTRODE MALFUNCTION aa. IONIZATION ELECTRODE CABLE MALFUNCTION bb. PRINTED CIRCUIT BOARD MALFUNCTION</p>	<p>z. CLEAN IT OR REPLACE PART aa. REPLACE PART bb. REPLACE PART</p>
E42	FAN PRINTED CIRCUIT BOARD	<p>cc. FAN PRINTED CIRCUIT BOARD MALFUNCTION - BEFORE REPLACING FAN CIRCUIT BOARD. MOMENTARILY DISCONNECT POWER TO THE APPLIANCE THEN RECONNECT POWER. IF ERROR CODE CLEARS AND APPLIANCE OPERATES NORMAL DO NOT REPLACE THE FAN CIRCUIT BOARD.</p>	<p>cc. REPLACE PART</p>

## 6.10 Diagnostics

### ■ Error codes:

- E01 Ionisation Lock Out
- E02 Safety Thermostat Tripped
- E03 Flue Gas Thermofuse Tripped
- H2O Low Water Pressure Alarm
- E05 Heating Sensor Malfunction
- E12 D.H.W Storage Cylinder Sensor Malfunction
- E16 Electric Fan Malfunction
- E22 Parameter Programming Request
- E35 Flame Detection Malfunction
- E42 Fan Speed P.C.B. Malfunction

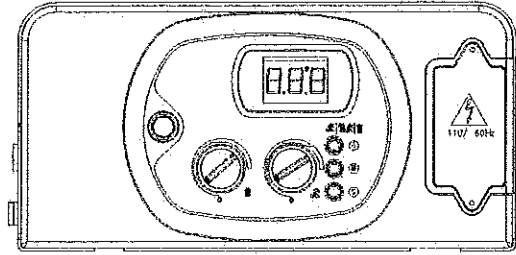

### ■ Function codes :

Code	Function	Description
07	Flue test function active (Chimney-Sweeper) "High Fire" Test	Pressing the "service" button for 7 seconds activates the Flue test function. Pressing the water heater off button deactivates the function. The Flue test function operates the water heater at the maximum heating pressure for 15 minutes without any modulation. The function is useful for combustion testing.
08	Frost Protection Central heating circuit	The function is activated when the heating sensor senses a temperature of 41 °F. The water heater operates at minimum gas pressure with the 3-way diverter valve in the winter position. The function is deactivated when the temperature detected by the sensor reaches 86°F.
09	Frost Protection D.H.W. circuit	The function is activated when the sensor senses a temperature of 40°F. The water heater operates at minimum gas pressure. The 3-way diverter valve closes in the summer position and heats the D.H.W. circuit. The function is deactivated when the D.H.W. sensor detects a temperature of 46°F.
31	Incompatible Remote Control	Function active when the remote control connected is not compatible with the printed circuit board.



## 6.11 Parts List / Available from PENSOTTI

### Main components

CODE	DESCRIPTION
20086LA	ISOTHERMIQUE 5+1 COMBUSTION CHAMBER BACK PANEL
21044LA	PRIMARY EXCHANGER 5+1 PREMIX 0.70
24060LA	PUMP STAR S 21 KU RSL-PL6 UL/CSA
25-00050	SAFETY VALVE 3/4"M - 3/4"F
27044LA	CONDENSATE TRAP
35031LA	IGNITION ELECTRODE
35032LA	IONISATION ELECTRODE
36072LA	VENTURI MINIFOLD
36075LA	GAS VALVE UL/CSA
37033LA	FAN UL/CSA
59015LA	LOW WATER CUT OUT SWITCH PC 5411 BRASS
59023LA	AIR PRESSURE SWITCH
73516LA	HTG CLIP SENSOR FOR PIPE 17/18 mm BLUE-T7335D1123B
73517LA	THERMO FUSE 102°C RED ISOTHERM . 1/4" 4X45
76702LA	PRINTED CIRCUIT BOARD KOND DT - SK11003
76719LA	MAIN PRINTED CIRCUIT BOARD UL/CSA - SM20021
86006LA	SAFETY THERMOSTAT 95°C
86014LA	WATER PRESSURE GAUGE
88022LA	TRANSFORMER UL/CSA
95013LA	EXPANSION VESSEL 7 lt. 3/8"
96018LA	NO-RETURN VALVE
96093LA	DIVERTER VALVE ACTUATOR UL/CSA (3-WAY VALVE)

## 6.12 Cycle Sequence of Operations

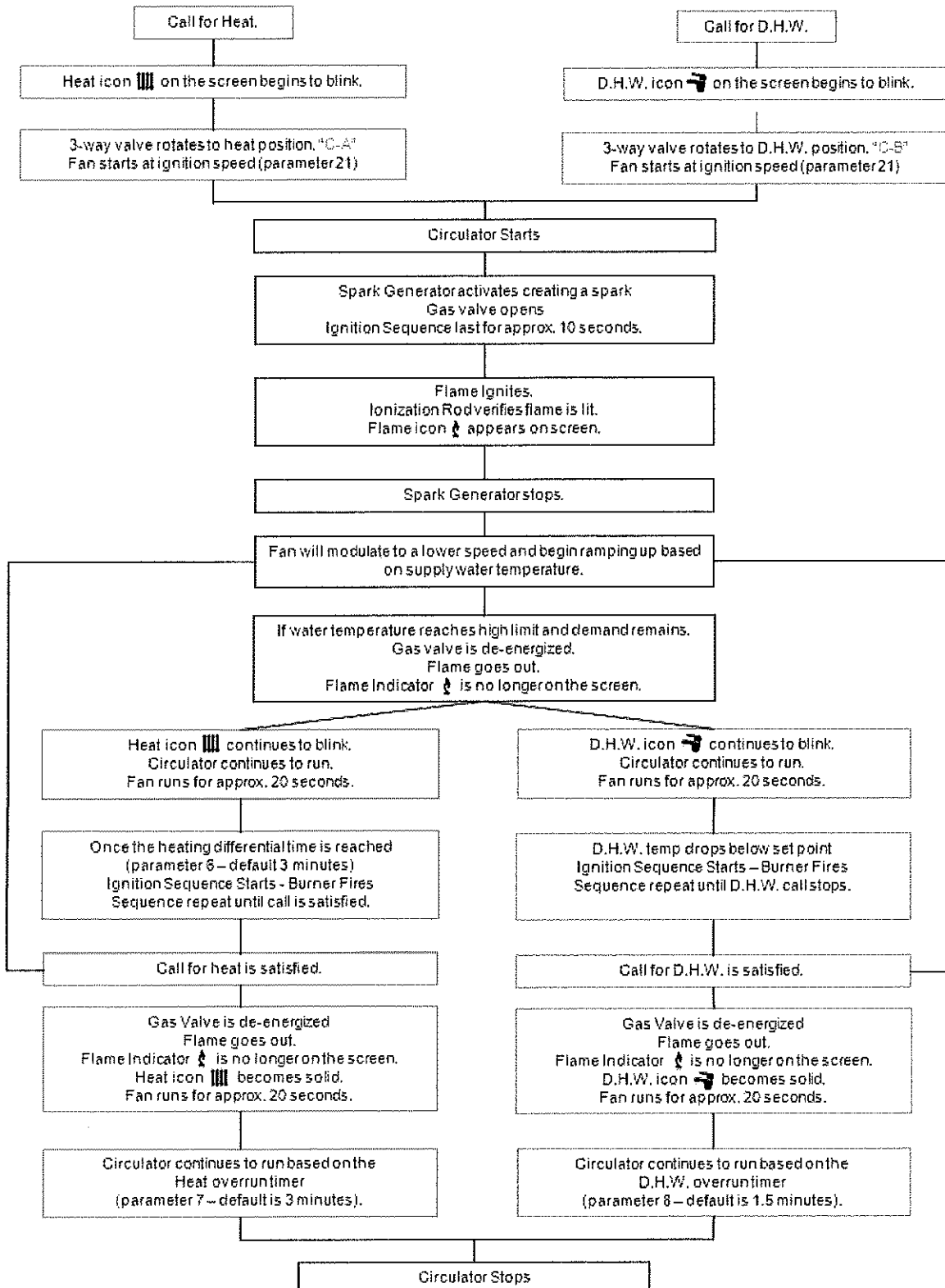

**Pensotti LLC**  
34 Coffin Ave Brewer, ME 04412  
P. 207-942-3636 F. 207-942-3737  
[www.pensottiboiler.com](http://www.pensottiboiler.com)

