

City of Portland, Maine - Building or Use Permit Application

389 Congress Street, 04101 Tel: (207) 874-8703, Fax: (207) 874-8716

Permit No: 05-0037	ISSUANCE DATE: JAN 18 2005	CBL: 162 F011001
OWNER NAME: Mckenny John F & Mary C Jts		OWNER ADDRESS: 86 Murray St
CONTRACTOR NAME: Frost N Flame		CONTRACTOR ADDRESS: 629 Main St. Portland
PERMIT TYPE: R-3		ZONE: R-3

Location of Construction: 86 Murray St	Owner Name: Mckenny John F & Mary C Jts	Owner Address: 86 Murray St
Business Name:	Contractor Name: Frost N Flame	Contractor Address: 629 Main St. Portland
Lessee/Buyer's Name	Phone:	Permit Type: R-3

Past Use: Single Family Home	Proposed Use: Single Family Home / Install Lopi Sturbridge Direct vent Gas stove
---------------------------------	---

Permit Fee: \$48.00	Cost of Work: \$2,372.57	CEO District: 4
Signature: <i>[Signature]</i> RICT (P.A.D.) Action: <input type="checkbox"/> Approved <input type="checkbox"/> Approved w/Conditions <input type="checkbox"/> Denied Signature: _____ Date: _____		

Proposed Project Description:
Install Lopi Sturbridge Direct vent Gas stove

Permit Taken By: Idobson	Date Applied For: 01/10/2005
-----------------------------	---------------------------------

- This permit application does not preclude the Applicant(s) from meeting applicable State and Federal Rules.
- Building permits do not include plumbing, septic or electrical work.
- Building permits are void if work is not started within six (6) months of the date of issuance. False information may invalidate a building permit and stop all work..

Special Zone or Reviews

Shoreland

Wetland

Flood Zone

Subdivision

Site Plan

Maj Minor MM

Date: 1/14/05

Zoning Appeal

Variance

Miscellaneous

Conditional Use

Interpretation

Approved

Denied

Date: _____

Historic Preservation

Not in District or Landmark

Does Not Require Review

Requires Review

Approved

Approved w/Conditions

Denied

Date: 1/14/05

CERTIFICATION

I hereby certify that I am the owner of record of the named property, or that the proposed work is authorized by the owner of record and that I have been authorized by the owner to make this application as his authorized agent and I agree to conform to all applicable laws of this jurisdiction. In addition, if a permit for work described in the application is issued, I certify that the code official's authorized representative shall have the authority to enter all areas covered by such permit at any reasonable hour to enforce the provision of the code(s) applicable to such permit.

SIGNATURE OF APPLICANT	ADDRESS	DATE	PHONE
RESPONSIBLE PERSON IN CHARGE OF WORK, TITLE		DATE	PHONE

City of Portland, Maine - Building or Use Permit

389 Congress Street, 04101 Tel: (207) 874-8703, Fax: (207) 874-8716

Permit No: 05-0037	Date Applied For: 01/10/2005	CBL: 162 F011001
------------------------------	--	----------------------------

Location of Construction: 86 Murray St	Owner Name: Mckenny John F & Mary C Jts	Owner Address: 86 Murray St	Phone:
Business Name:	Contractor Name: Frost N Flame	Contractor Address: 629 Main St. Portland	Phone:
Lessee/Buyer's Name	Phone:	Permit Type: HVAC	

Proposed Use: Single Family Home / Install Lopi Sturbridge Direct vent Gas stove	Proposed Project Description: Install Lopi Sturbridge Direct vent Gas stove
--	---

Dept: Zoning **Status:** Approved **Reviewer:** Tammy Munson **Approval Date:** 01/14/2005
Note: **Ok to Issue:**

Dept: Building **Status:** Approved with Conditions **Reviewer:** Tammy Munson **Approval Date:** 01/14/2005
Note: **Ok to Issue:**

1) The installation must comply with the State of Maine Gas Regulations.



FILL IN AND SIGN WITH INK

APPLICATION FOR PERMIT HEATING OR POWER EQUIPMENT



To the INSPECTOR OF BUILDINGS, PORTLAND, ME.

The undersigned hereby applies for a permit to install the following heating, cooking or power equipment in accordance with the Laws of Maine, the Building Code of the City of Portland, and the following specifications:

'62711
 Location / CBL 86 Murray St Portland Use of Building Residential Date 1/5/05
 Name and address of owner of appliance Cathy McKenney 86 Murray St. Portland ME
 Installer's name and address Dennis Knudsen Frost + Flame 609 Main St. Braham ME
 Telephone 207-856-7000

Location of appliance:

- Basement
- ^{1st} Floor
- Attic
- Roof

Type of Fuel:

- Gas LP
- Oil
- Solid

Appliance Name:

Lopi Sturbodse

U.L. Approved Yes No

Will appliance be installed in accordance with the manufacture's installation instructions? Yes No

IF NO Explain: _____

The Type of License of Installer:

- Master Plumber # _____
- Solid Fuel # _____
- Oil # _____
- Gas # : PNT1606
- Other _____

Type of Chimney:

- Masonry Lined
Factory built _____
- Metal
Factory Built U.L. Listing # _____

Direct vent
Type Simpson

UL# 3AV98

Type of Fuel Tank

- Oil
- Gas LP

Size of Tank 100

Number of Tanks 1

Distance from Tank to Center of Flame 25 feet.

Cost of Work: \$ 2372.57

Permit Fee: \$ 18

Approved

Fire: _____

Ele.: _____

Bldg.: _____

Approved with Conditions

See attached letter on requirement

Inspector's Signature

Date Approved

Signature of Installer M. D. Heath

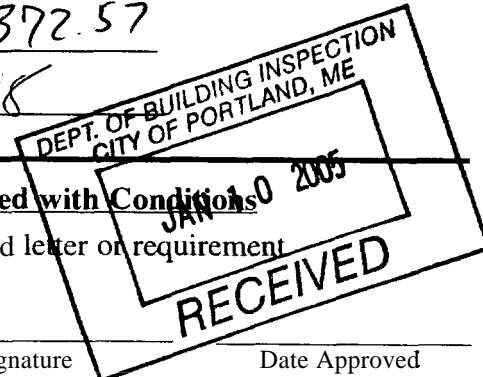

Specifications

Features:

- Ember Fyre™ Burner for "Wood Fire" Look
- Works During Power Outages (millivolt system)
- High Efficiency
- Optional Thermostat or Remote Control
- Optional Blower for Quicker Heat Distribution
- Convenient Operating Controls
- Variable-Rate Heat Output
- Low Maintenance

Installation Options:

- Freestanding Stove
- Horizontal or Vertical Vent
- Residential or Mobile Home
- Straight or Corner Placement
- Bedroom Approved

Heating Specifications:

Approximate Heating Capacity (in square feet)*.....up to 850 with Blower, up to 650 Without

Maximum Input (in BTU's).....18,000

Minimum Output On Low (in BTU's).....9,900

Steady State Efficiency.....up to 80.1%

AFUE (without blower)Up to 67.8%

- Heating capacity will vary depending on the home's floor plan, degree of insulation, and the outside temperature.
- ** Efficiency rating is a product of thermal efficiency rating determined under continuous operation independent of installed system.

Dimensions & Weight:

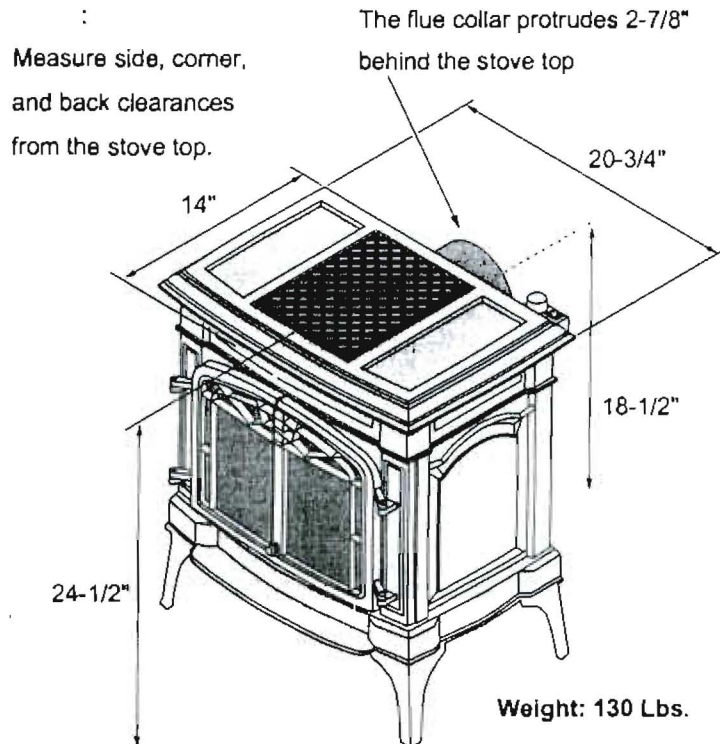

Electrical Specifications (for optional blower)

Electrical Rating.....115 Volts, 1.3 Amps, 60 Hz (150 watts on high)

Fuel:

- This heater is shipped in natural gas (NG) configuration but may be converted to propane (LP) using the included LP conversion kit. The sticker on top of the gas control valve will verify the correct fuel.