

DISPLAY THIS CARD ON PRINCIPAL FRONTAGE OF WORK



CITY OF PORTLAND

BUILDING PERMIT

This is to certify that ST. IGNATIUS RESIDENCE

Located At 267 OCEAN AVE

Job ID: 2012-08-4615-ALTCOMM

CBL: 156-F-001-001

has permission to Replace snackbar hood w/ Compliant Hood & Duct

provided that the person or persons, firm or corporation accepting this permit shall comply with all of the provisions of the Statutes of Maine and of the Ordinances of the City of Portland regulating the construction, maintenance and use of the buildings and structures, and of the application on file in the department.

Notification of inspection and written permission procured before this building or part thereof is lathed or otherwise closed-in. 48 HOUR NOTICE IS REQUIRED.

A final inspection must be completed by owner before this building or part thereof is occupied. If a certificate of occupancy is required, it must be

Fire Prevention Officer

A handwritten signature in black ink, appearing to read 'Jamie Bonke', written over a horizontal line.

Code Enforcement Officer / Plan Reviewer

**THIS CARD MUST BE POSTED ON THE STREET SIDE OF THE PROPERTY
PENALTY FOR REMOVING THIS CARD**

BUILDING PERMIT INSPECTION PROCEDURES

Please call 874-8703 or 874-8693 (ONLY)

or email: buildinginspections@portlandmaine.gov

With the issuance of this permit, the owner, builder or their designee is required to provide adequate notice to the city of Portland Inspections Services for the following inspections. Appointments must be requested 48 to 72 hours in advance of the required inspection. The inspection date will need to be confirmed by this office.

- **Please read the conditions of approval that is attached to this permit!! Contact this office if you have any questions.**
- **Permits expire in 6 months. If the project is not started or ceases for 6 months.**
- **If the inspection requirements are not followed as stated below additional fees may be incurred due to the issuance of a "Stop Work Order" and subsequent release to continue.**

Close In Elec/Plmb/Frame prior to insulate or gyp

Final Inspection

The project cannot move to the next phase prior to the required inspection and approval to continue, REGARDLESS OF THE NOTICE OF CIRCUMSTANCES.

IF THE PERMIT REQUIRES A CERTIFICATE OF OCCUPANCY, IT MUST BE PAID FOR AND ISSUED TO THE OWNER OR DESIGNEE BEFORE THE SPACE MAY BE OCCUPIED.



PORTLAND MAINE

Strengthening a Remarkable City, Building a Community for Life • www.portlandmaine.gov

Director of Planning and Urban Development
Jeff Levine

Job ID: 2012-08-4615-ALTCOMM

Located At: 267 OCEAN AVE

CBL: 156- F-001-001

Conditions of Approval:

Building

1. Application approval based upon information provided by the applicant or design professional. Any deviation from approved plans requires separate review and approval prior to work.
2. Equipment shall be installed in compliance with the manufacturer's specifications and the UL listing.
3. The hood, duct and exhaust shall be installed per NFPA 96.
4. This permit is approved based on the plans submitted for reductions in the clearances based on the application of a UL approved fire wrap or equivalent assembly per code.
5. Separate permits are required for any electrical, plumbing, sprinkler, fire alarm, HVAC systems, heating appliances, including pellet/wood stoves, commercial hood exhaust systems and fuel tanks. Separate plans may need to be submitted for approval as a part of this process.

Fire

Installation shall comply with City Code Chapter 10.

Installation shall comply with NFPA 211, *Standard for Chimneys, Fireplaces, Vents, and Solid Fuel-Burning Appliances*;

NFPA 54, *National Fuel Gas Code*;

NFPA 91, *Standard for Exhaust Systems for Air Conveying Vapors, Gases, Mists, and Noncombustible Particulate Solids*;

NFPA 70, *National Electrical Code*; and the manufacturer's published instructions.

-2012-08-4615-

8-3



General Building Permit Application

If you or the property owner owes real estate or personal property taxes or user charges on any property within the City, payment arrangements must be made before permits of any kind are accepted.

Location/Address of Construction: <u>267 Ocean Ave Cheverus-</u>		
Total Square Footage of Proposed Structure		Square Footage of Lot
Tax Assessor's Chart, Block & Lot Chart# Block# Lot# <u>56 F 1</u>	Owner: <u>Cheverus St. Ignace Residence</u> <u>The Society of Jesus</u>	Telephone:
Lessee/Buyer's Name (If Applicable)	Applicant name, address & telephone: <u>Airtemp Inc</u> <u>11 Wallace Ave South Portland</u> <u>Maine 04106 207-774-2300</u>	Cost Of Work: \$ <u>18,600</u> Fee: \$ <u>210</u> C of O Fee: \$ _____
Current legal use (i.e. single family) <u>School</u> If vacant, what was the previous use? _____ Proposed Specific use: <u>no change</u> Is property part of a subdivision? _____ If yes, please name _____ Project description: <u>Replace the existing snackbar kitchen hood with new NFPA 96 compliant hood, duct and fan.</u>		
Contractor's name, address & telephone: <u>Airtemp Inc.</u>		
Who should we contact when the permit is ready: <u>Geoff Gerdler</u> Mailing address: <u>11 Wallace Ave South Portland, Maine 04106</u> Phone: <u>207-774-2300</u>		

RECEIVED
AUG 03 2012
Dept. of Building Inspections
City of Portland, Maine

Please submit all of the information outlined in the Commercial Application Checklist. Failure to do so will result in the automatic denial of your permit.

In order to be sure the City fully understands the full scope of the project, the Planning and Development Department may request additional information prior to the issuance of a permit. For further information or to download copies of this form and other applications visit the Inspections Division on-line at www.portlandmaine.gov, or stop by the Inspections Division office, room 315 City Hall or call 874-8703.

I hereby certify that I am the Owner of record of the named property, or that the owner of record authorizes the proposed work and that I have been authorized by the owner to make this application as his/her authorized agent. I agree to conform to all applicable laws of this jurisdiction. In addition, if a permit for work described in this application is issued, I certify that the Code Official's authorized representative shall have the authority to enter all areas covered by this permit at any reasonable hour to enforce the provisions of the codes applicable to this permit.

Signature of applicant:  Date: 8/3/12

This is not a permit; you may not commence ANY work until the permit is issued.

Grease Gutters provided? Yes

Hood Clearance reduction to Combustibles design /specs:

3" Standoff Rear.

Duct Clearance reduction to Combustibles design /specs:

Where less than 16" from combustibles (Notably at the roof deck penetration and just below the ceiling) the duct shall have 2- 1.5" layers Zero Clearance duct insulation 3M

Vibration Isolation System: Firebarrier 615+

Integral to fan

Air Velocity within the duct system 1500 FPM

Grease accumulation prevention system:

Captive Aire aluminum baffle filters. Grease box on EF.

Cleanouts Per NFPA 96

Grease Duct enclosure NA

Exhaust Termination Roof x Wall

Fire Suppression System Yes. Amerex

Exhaust fan mounting and clearance from the roof / wall or Combustibles:

20" High vented hinged curb. Upblast UL Listed Kitchen fan

Exhaust fan distance from property lines ~ 125 feet

Exhaust fan distance from other vents or openings 30 feet

Exhaust fan distance from adjacent buildings 17 feet

Exhaust fan height above adjoining grade 16 Feet

Hood Specs

Style of Hood Wall Canopy

Type of Filter Aluminum Baffle

Height of filter above nearest cooking surface 48"

Capacity of hood CFM 1575

Make up Air system description and capacity

Two (2) existing Trane Air- handling units 4000 CFM Each.



Cheverus Snack Bar Hood
Code upgrade and replacement

New Up blast Fan
Location.

Cap former
exhaust location.

s/?FORM=HDRSC4#

Owner: Cheverus High School
Construction Manager: Siemens Industries
Installing Contractor: Airtemp Inc.

Airtemp job# 12-421

HOOD INFORMATION

HOOD NO.	MODEL	LENGTH	MAX. COOKING TEMP.	EXHAUST PLENUM RISER(S)					SUPPLY PLENUM RISER(S)					HOOD CONSTRUCTION	HOOD CONFIG.		
				TOTAL EXH. CFM	WIDTH	LENG.	DIA.	CFM	S.P.	TOTAL SUP. CFM	WIDTH	LENG.	DIA.		CFM	S.P.	END TO END
1	4824 ND-2	7' 0.00"	500 Deg.	1575			14"	1575	-0.395"	0					430 SS Where Exposed	ALONE	ALONE

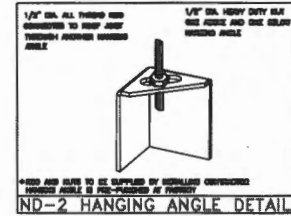

HOOD INFORMATION

HOOD NO.	FILTER(S)	LIGHT(S)			UTILITY CABINET(S)			FIRE SYSTEM	ELECTRICAL	SWITCHES	FIRE SYSTEM PIPING	HOOD HANGING WGT
		QTY.	HEIGHT	LENGTH	QTY.	TYPE	WIRE GUARD					
1	Alum Baffle w/ Handles	4	16"	16"	2	Screw In Compact Fluore	NO				NO	341 LBS

HOOD OPTIONS

HOOD NO.	OPTION
1	FIELD WRAPPER 24.00' High Front, Left, Right
	BACKSPASH 80.00' High X 84.00' Long 430 SS
	RIGHT QUARTER END PANEL 23' Top Width, 0' Bottom Width, 23' High 430 SS
	LEFT QUARTER END PANEL 23' Top Width, 0' Bottom Width, 23' High 430 SS

SPECIFICATIONS

THE RESTAURANT FIRE SUPPRESSION SYSTEM SHALL BE THE PRE-ENGINEERED TYPE WITH A FIXED NOZZLE AGENT DISTRIBUTION NETWORK. IT SHALL BE LISTED WITH UNDERWRITERS LABORATORIES, INC. (UL)

THE SYSTEM SHALL BE CAPABLE OF AUTOMATIC DETECTION AND ACTUATION WITH LOCAL OR REMOTE MANUAL ACTUATION. ACCESSORIES SHALL BE AVAILABLE FOR MECHANICAL OR ELECTRICAL GAS LINE SHUT-OFF APPLICATIONS.

THE EXTINGUISHING AGENT SHALL BE A POTASSIUM CARBONATE, POTASSIUM ACETATE-BASED FORMULATION DESIGNED FOR FLAME KNOCKDOWN AND SECUREMENT OF GREASE RELATED FIRES. IT SHALL BE AVAILABLE IN PLASTIC CONTAINERS WITH INSTRUCTIONS FOR LIQUID AGENT HANDLING AND USAGE.

THE REGULATED RELEASE MECHANISM SHALL BE COMPATIBLE WITH A FUSIBLE LINK DETECTION SYSTEM. THE FUSIBLE LINK SHALL BE SELECTED AND INSTALLED ACCORDING TO THE OPERATING TEMPERATURE IN THE VENTILATING SYSTEM. THE FUSIBLE LINK SHALL BE SUPPORTED BY A DETECTOR BRACKET/LINKAGE ASSEMBLY.

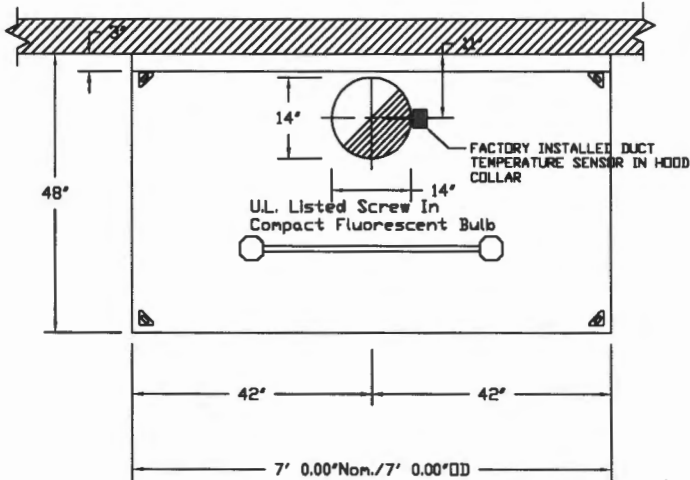

PLAN VIEW - Hood #1
7' 0.00" LONG 4824ND-2

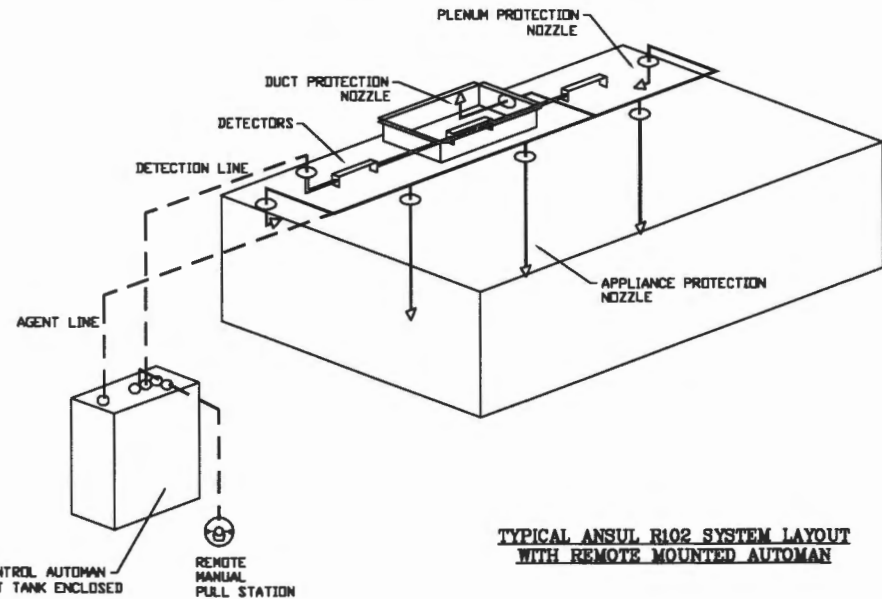

TYPICAL ANSUL R102 SYSTEM LAYOUT WITH REMOTE MOUNTED AUTOMAN

CUSTOMER APPROVAL TO MANUFACTURE:

Approved as Noted

Approved with NO Exception Taken

Revise and Resubmit

SIGNATURE _____

Your Title _____ Date _____



JOB	Cheverus Snack Bar r5
LOCATION	SOUTH PORTLAND, ME
DATE	7/24/2012
JOB #	1596565
DWG #	1
DRAWN BY	BFC-21
REV.	SCALE 3/8" = 1'-0"

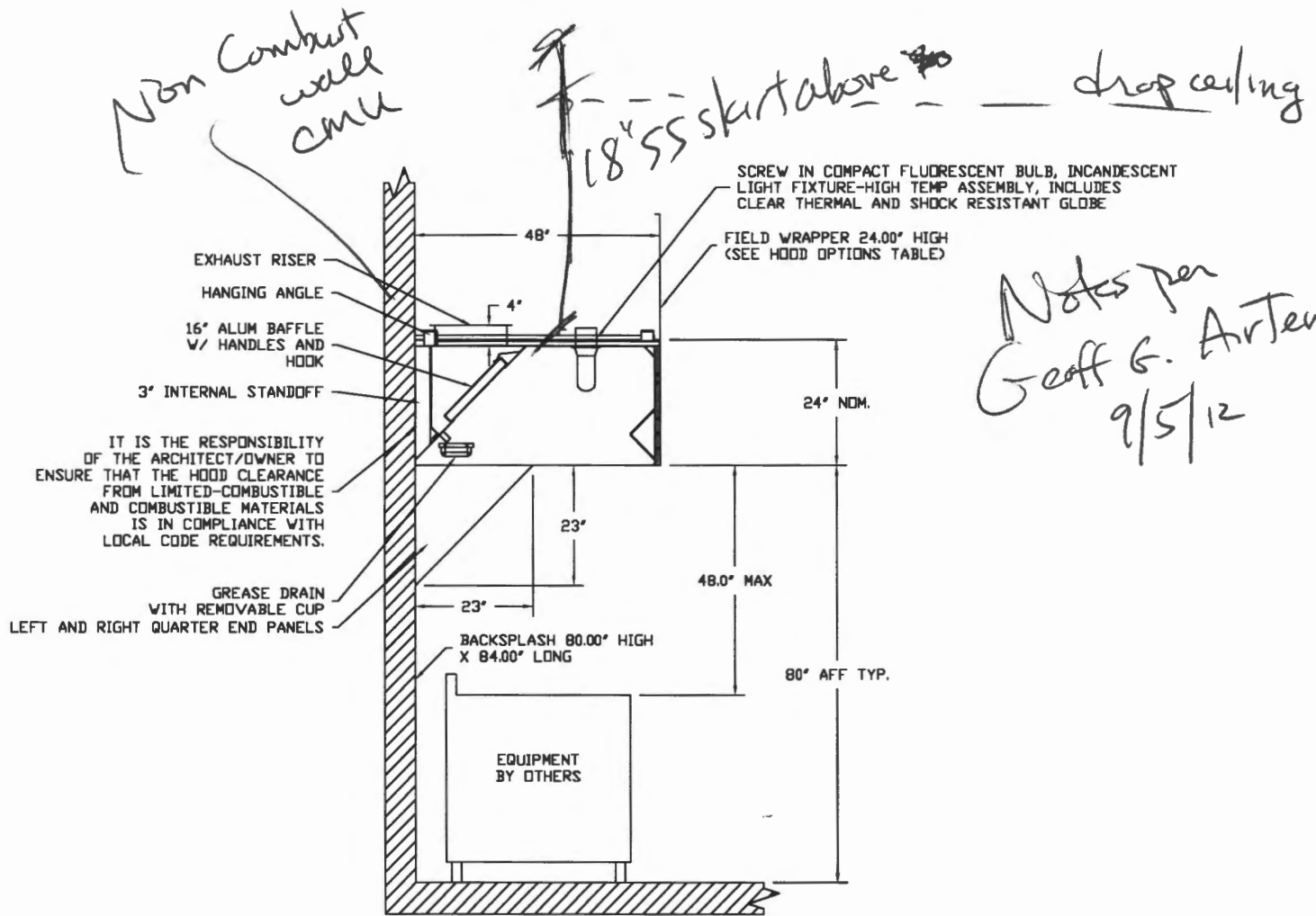

Notes per
Geoff G. ArTemp
9/5/12

SECTION VIEW - MODEL 4824ND-2

CUSTOMER APPROVAL TO MANUFACTURE:

Approved as Noted

Approved with NO Exception Taken

Revise and Resubmit

SIGNATURE _____

Your Title _____ Date _____

CAPTIVE AIR

JOB Cheverus Snack Bar r5	
LOCATION SOUTH PORTLAND, ME	
DATE 7/24/2012	JOB # 1596565
DWG # 2	DRAWN BY BFC-21
REV.	SCALE 3/8" = 1'-0"

EXHAUST FAN INFORMATION

FAN UNIT NO.	FAN UNIT MODEL #	MODEL	TAG	CFM	ESP.	RPM	H.P.	#	VOLT	FLA	WEIGHT (LBS.)	SDNES
1	NCA14FA	NCA14FA		1575	0.600	956	0.500	3	208	1.8	155.14	8.6

FAN OPTIONS

FAN UNIT NO.	OPTION (Qty. - Descr.)
1	1 - Grease Box
	1 - Full Crating For Exhaust Fans
	1 - Fan Base Ceramic Seal - For Grease Ducts
	1 - EPO15-Tan Enamel Coating

CURB ASSEMBLIES

NO.	DN FAN	WEIGHT	ITEM	SIZE
1	# 1	36 LBS	Curb	23.000"W x 23.000"L x 20.000"H Vented Hinged

FAN #1 NCA14FA - EXHAUST FAN

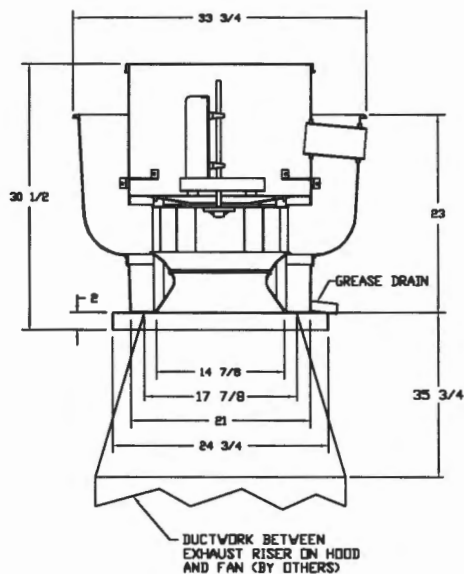

FEATURES:

- ROOF MOUNTED FANS
- RESTAURANT MODEL
- UL705 AND UL762
- AMCA SOUND AND AIR CERTIFIED
- WIRING FROM MOTOR TO DISCONNECT SWITCH
- WEATHERPROOF DISCONNECT
- HIGH HEAT OPERATION 300°F (149°C)
- GREASE CLASSIFICATION TESTING

NORMAL TEMPERATURE TEST
EXHAUST FAN MUST OPERATE CONTINUOUSLY WHILE EXHAUSTING AIR AT 300°F (149°C) UNTIL ALL FAN PARTS HAVE REACHED THERMAL EQUILIBRIUM, AND WITHOUT ANY DETRIMENTARY EFFECTS TO THE FAN WHICH WOULD CAUSE UNSAFE OPERATION.

ABNORMAL FLARE-UP TEST
EXHAUST FAN MUST OPERATE CONTINUOUSLY WHILE EXHAUSTING BURNING GREASE VAPORS AT 600°F (316°C) FOR A PERIOD OF 15 MINUTES WITHOUT THE FAN BECOMING DAMAGED TO ANY EXTENT THAT COULD CAUSE AN UNSAFE CONDITION.

OPTIONS

- GREASE BOX
- FULL CRATING FOR EXHAUST FANS
- FAN BASE CERAMIC SEAL - FOR GREASE DUCTS
- EPO15-TAN ENAMEL COATING

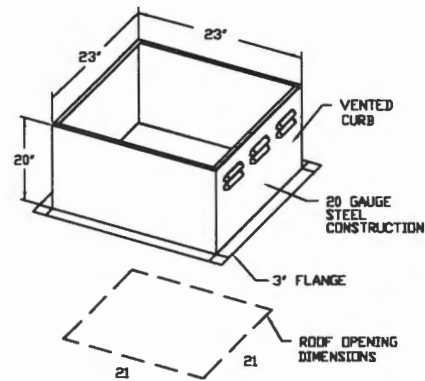

CUSTOMER APPROVAL TO MANUFACTURE:

Approved as Noted

Approved with NO Exception Taken

Revise and Resubmit

SIGNATURE _____

Your Title _____ Date _____



CAPTIVE AIR

JOB	Cheverus Snack Bar r5
LOCATION	SOUTH PORTLAND, ME
DATE	7/24/2012
JOB #	1596565
DWG #	3
DRAWN BY	BFC-21
REV.	SCALE 3/8" = 1'-0"

ELECTRICAL PACKAGES

NO.	TAG	PACKAGE #	LOCATION	SWITCHES		OPTION	FANS CONTROLLED				
				LOCATION	QUANTITY		TYPE	#	H.P.	VOLT	FLA
1		ENS10102	Wall Mount In SS Box	SS Wall Mount Box	1 Light 1 Fan 1 Other	EMS 02: Exhaust in Fire, Lights out in Fire	Exhaust	3	0.500	208	1.8

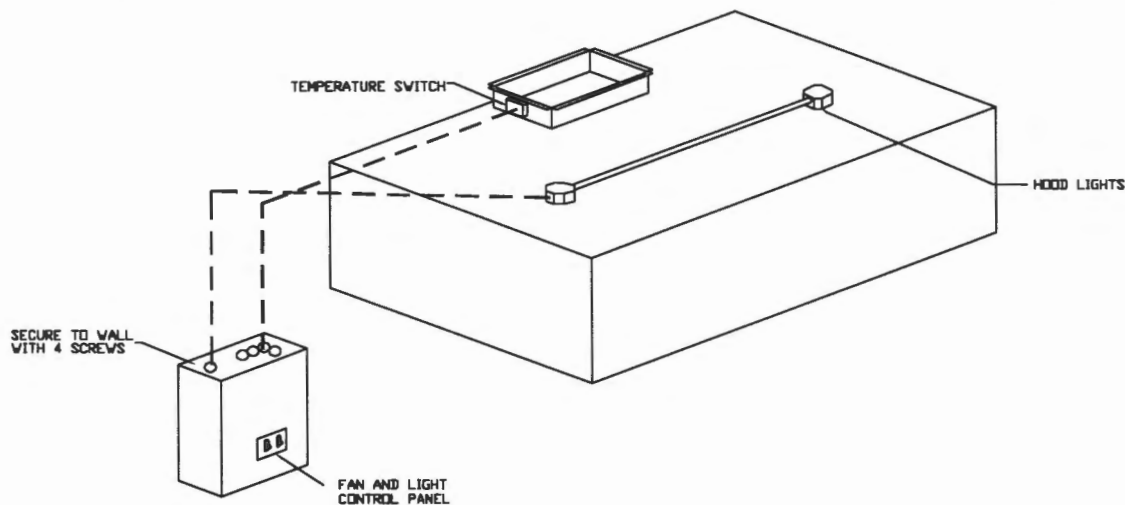

WALL MOUNTED ENERGY MANAGEMENT SYSTEM

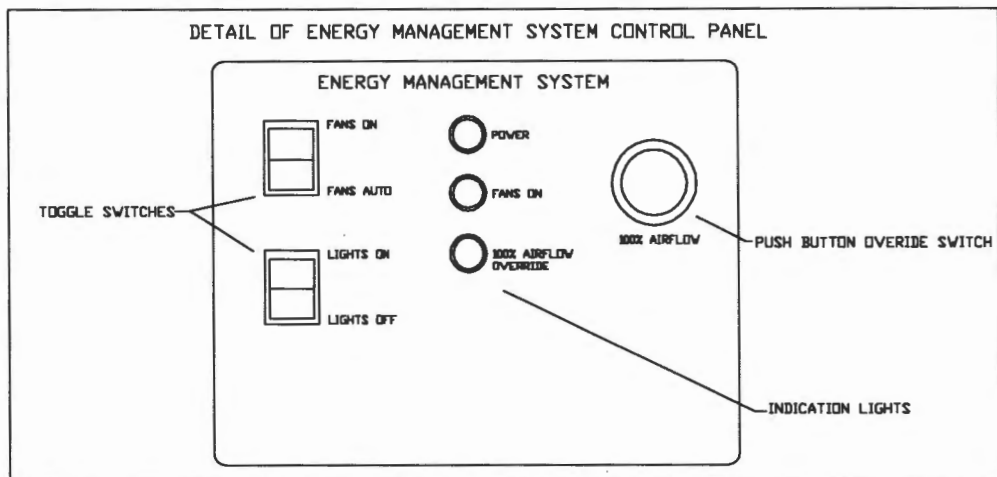

WALL MOUNTED EMS SYSTEM

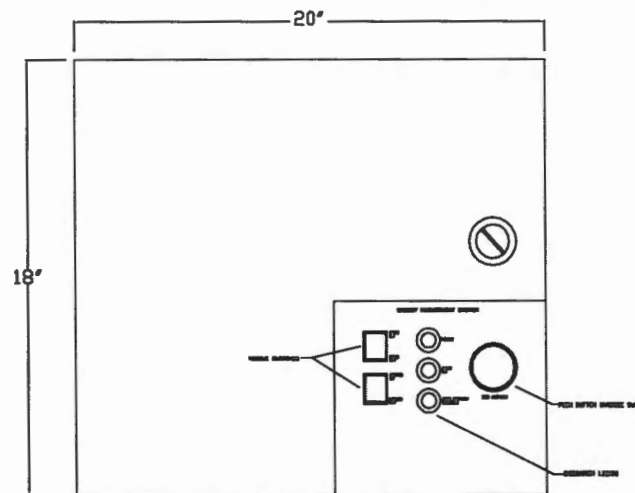

CUSTOMER APPROVAL TO MANUFACTURE:

Approved as Noted

Approved with NO Exception Taken

Revise and Resubmit

SIGNATURE _____

Your Title _____ Date _____



JOB Cheverus Snack Bar r5	
LOCATION SOUTH PORTLAND, ME	
DATE 7/24/2012	JOB # 159656
DWG # 4	DRAWN BY BFC-21
REV.	SCALE 3/8" = 1'-0"

Model: EMS Series

Certifications: Controls shall be listed by ETL (UL 508A).

Application:

The Energy Management System (EMS) is capable of saving energy during idle cooking periods. The EMS is designed to automatically reduce exhaust and supply airflow quantities, while ensuring hood performance is maintained. The EMS uses Variable Frequency Drives (VFD) and temperature sensors in the exhaust ducts to modulate the fan speed during cooking operations and maximize energy savings. A 100% airflow override button shall be supplied with an adjustable timer.

Construction:

Controls shall be listed by ETL (UL 508A). The control interface shall include (1) fan switch, (1) hood light switch, (1) 100% airflow override push button and indicator lights. Indicator lights shall include a "power" light, a "fans on" light, and a "100% airflow override" light. The control interface shall be screen printed on stainless steel and be able to be installed on the face of the hood, face of the utility cabinet, or on the face of the control enclosure.

The control enclosure shall be NEMA 1 rated and listed for installation inside of the exhaust hood utility cabinet. The control enclosure may be constructed of stainless steel or painted steel.

Variable frequency drives shall allow full adjustment of minimum and maximum frequency set-point for proper kitchen balance. Drives shall contain motor thermal overload protection. Acceleration and deceleration times shall be fully adjustable. Drives are capable of controlling up to 20HP motor each.

Resistive Temperature Detector (RTD) shall be mounted in the exhaust hood riser(s). Temperature probe shall be constructed of Stainless Steel. System shall be factory pre-set to modulate fan speed between 85°F and 130°F for 600°F and 700°F cooking applications and between 85°F and 90°F for 400°F cooking applications. Set-points shall be fully adjustable through the temperature controllers inside the control panel based on application needs.

The 100% override timer shall be adjustable from .05 seconds to 30 days. Timer is energized with 100% Airflow Override button. When button is depressed, time starts and fans go to high speed. Upon timeout, fans return to low speed or speed dictated by temperature sensors.

The panels include color coded wiring with as-built wiring diagrams, and spare terminals controlled by the fire system micro switch. The panel is factory pre-wired to shut down supply fans in a fire condition. There is also a factory pre-wire option to turn on the exhaust fans in a fire condition (if required).

CUSTOMER APPROVAL TO MANUFACTURE:	
Approved as Noted	<input type="checkbox"/>
Approved with NO Exception Taken	<input type="checkbox"/>
Revise and Resubmit	<input type="checkbox"/>
SIGNATURE: _____	
Your Title _____	Date _____



CAPTIVE AIR

JOB Cheverus Snack Bar r5	
LOCATION SOUTH PORTLAND, ME	
DATE 7/24/2012	JOB # 1596565
DWG # 5	DRAWN BY BFC-21
REV.	SCALE 3/8" = 1'-0"

Exhaust Fan Wiring

JOB NAME *Cheverus Snack Bar r5*

DATE *7/24/2012*

DRAWING NUMBER *EXH1596565-1*

JOB NUMBER *1596565*

MODEL **NCAL4FA**

Installed Options

1
2
3
4
5
6
7
8
9
10
11
12
13
14
15
16
17
18
19
20
21
22
23

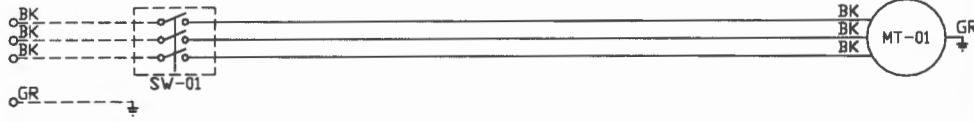

<u>Component Identification</u>		
<u>Label</u>	<u>Description</u>	<u>Location</u>
MT-01	Fan Motor	[2]

SW-01 Main disconnect switch [2]

MOTOR INFO
EXHAUST 0.5HP-208V-3P-1.8FLA

ELECTRICAL INFORMATION
MOTOR/CONTROL MCA: 2.3A
MOTOR/CONTROL MOP: 15A

NOTES
----- DENOTES FIELD WIRING
————— DENOTES INTERNAL WIRING

WIRE COLOR
BK - BLACK YW - YELLOW
BL - BLUE GR - GREEN
BR - BROWN GY - GRAY
OR - ORANGE PR - PURPLE
RD - RED PK - PINK
WH - WHITE

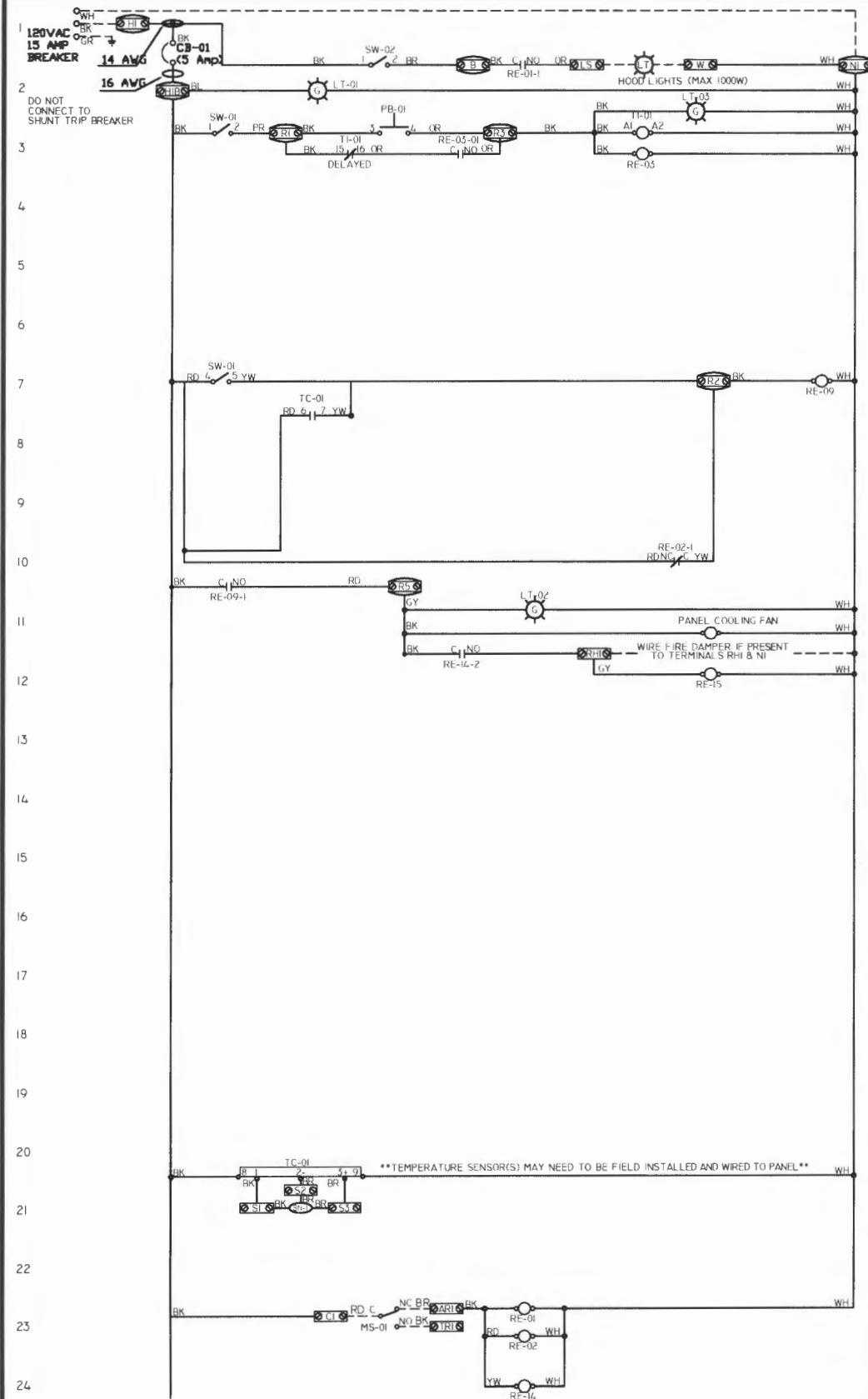

INSTALLER OPTIONS

HOOD LIGHT SWITCH (MAX 1000 W)	
EXHAUST ON IN FIRE	
LIGHTS OUT IN FIRE	

COMPONENT IDENTIFICATION

LABEL	DESCRIPTION	LOCATION
CB-01	CIRCUIT BREAKER UL489 (5 AMP)	[1]
LT-01	"POWER ON" LIGHT-PF50CG5-120VAC-W6	[2]
LT-02	"FANS ON" LIGHT-PF50CG5-120VAC-W6	[0]
LT-03	"100% OVERRIDE" LIGHT-PF50CG5-120VAC-W6	[2]
MS-XX	FIRE SYSTEM MICRO-SWITCH	[23]
PB-01	PUSH BUTTON OVERRIDE-D7-F2XII	[2]
RE-01	FIRE DPDT RELAY-3A,110.0184.0	[26][27]
RE-02	FIRE DPDT RELAY-3A,110.0184.0	[6][14]
RE-03	TIMER/PUSH BUTTON RELAY-3A,110.0184.0	[2]
RE-09	FAN ON RELAY-3A,110.0184.0	[5][28]
RE-14	FIRE DPDT RELAY-3A,110.0184.0	[24][1]
RE-15	RUN RELAY DPDT RELAY-3A,110.0184.0	[9][16]
SM-01	EXH SPEED CONTROL-SM-V SERIES	[27-31]
SN-XX	TEMPERATURE SENSOR - A/100-SW-PO-4'-EXPL	[21-22]
SW-01	FAN ON/AUTO SWITCH-RE24ZD100	[2][29]
SW-02	HOOD LIGHT SWITCH-RE24ZD100	[1]
TC-XX	TEMPERATURE CONTROLLER-PAR3 WADIN RAIL MOUNT	[6-42]
TI-01	100% OVERRIDE TIMER (30 MINUTES)-R27-FSA6JL23	[2][29]

SPARE RELAY CONTACTS

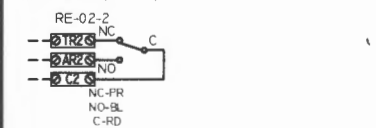

NO	4	5
NC	2	
COM	6	7
COM	6	5

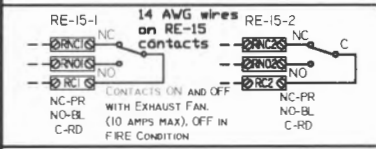

- NOTES
- FIELD WIRING
 - INTERNAL WIRING
 - TERMINAL IN PANEL
 - TERMINAL IN PANEL AND REMOTE
 - DRAWING SHOWN DE-ENERGIZED.
- WIRE COLOR
- BK - BLACK
 - BL - BLUE
 - BR - BROWN
 - OR - ORANGE
 - RD - RED (STRIPE)
 - WH - WHITE (STRIPE)
 - PR - PURPLE
 - PK - PINK
 - YW - YELLOW
 - GR - GREEN
 - GY - GRAY
 - OR/BL - ORANGE/BLUE (STRIPE)
 - BL/RD - BLUE/RED (STRIPE)
 - PR - PURPLE (STRIPE)
 - RD/GN - RED/GREEN (STRIPE)

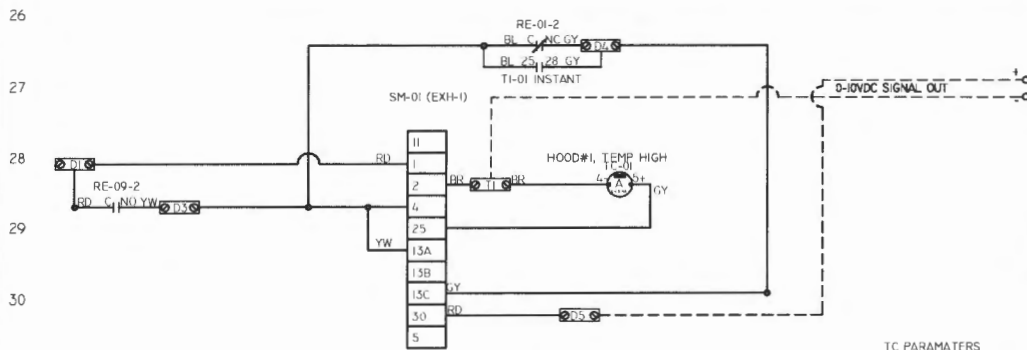

TC PARAMETERS
(600-450° Hoods)

SV = 85

LEVEL 1:
AL-H = 85
AL2 = 90

LEVEL 2:
P = 2.5 [P-(SV-H)-(SV-L)]/2

LEVEL 3:
SV-L = 85
SV-H = 90

TC PARAMETERS
(600-700° Hoods)

SV = 85

LEVEL 1:
AL-H = 85
AL2 = 130

LEVEL 2:
P = 22.5 [P-(SV-10)-(SV-L)]/2

LEVEL 3:
SV-L = 85
SV-H = 130

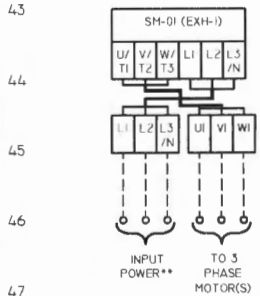

48 ALL EXTERNAL CONTROL WIRES TO MOTOR SPEED CONTROL SHOULD BE 16-20 AWG SHIELDED MULTICONDUCTOR CABLES AND MUST NOT BE RUN IN THE SAME CONDUIT OR RACEWAY WITH ANY HIGH POWER WIRING. GROUND SHIELDED CABLE AT THE DRIVE CHASSIS ONLY.

49 PG. 14 OF THE AC TECH SMV DRIVE MANUAL DESCRIBES THE ELECTRICAL INSTALLATION.

50 PG. 23 OF THE AC TECH SMV DRIVE MANUAL DESCRIBES THE PARAMETER SETTINGS OF THE DRIVE.

INSTALLED OPTIONS

HOOD LIGHT SWITCH (MAX 1000 W)	
EXHAUST ON IN FIRE	
LIGHTS OUT IN FIRE	

COMPONENT IDENTIFICATION

LABEL	DESCRIPTION	LOCATION
RE-01	DPDT RELAY-34.110.0184.0	[23]25
RE-09	FAN ON RELAY-34.110.0184.0	[5]26
SM-01	EXH SPEED CONTROL-SMV SERIES	[27-31]
TC-XX	TEMPERATURE CONTROLLER-PXR3 W/DIN RAIL MOUNT	

GENERAL DRIVE PARAMETER SETTINGS (PW = 275)

EXHAUST FAN DRIVERS
EPM PROGRAM #03

PI00	01 (TERM STRIP)
PI01	03 (PRESET #1)
PI02	0 HZ (MIN FREQ)
PI03	60 HZ (MAX FREQ)
PI04	50 SEC. (ACCEL TIME)
PI05	50 SEC. (DECEL TIME)
PI10	03 (AUTO RESTART)
PI21	02 (4-20 MA)
PI22	03 (PRESET SPEED #2)
PI23	03 (PRESET SPEED #3)
PI32	15 HZ (WASH CYCLE FREQ)
PI33	60 HZ (MUST MATCH PID)
PI36	60 HZ (MUST MATCH PIC)
PI40	01 (RUN)
PI44	00 (NO INVERSE PI40)
PI50	01 (0-10 VDC OUTPUT)
PI51	01 (ADD TB-5 TO TB-30)
PI52	60 HZ (-PI61)*EXH FAN
PI60	48 HZ (MIN SIGNAL SPEED)
PI61	60 HZ (MAX SIGNAL SPEED)
PI66	0 (CARRIER FREQ = K)
PI71	150 (CURRENT LIMIT = 15C)

ADJUST MANUALLY ON ALL DRIVES
PI07 = 00 (IF 120 OR 208 VAC) OR 01 (IF 230, 480 OR 575 VAC)
PI08 = Motor FLA > 100 / DRIVE OUTPUT RATING

SPEED #	TB-15	TB-18	TB-37
2 (PI-32)	OPEN	CLOSED	OPEN
3 (PI-33)	OPEN	OPEN	CLOSED
6 (PI-36)	OPEN	CLOSED	CLOSED

MOTOR INFORMATION

MOTOR	TAG	PH	VOLT	HP	FLA	BRF
EXH		3	208	0.5	1.8	5A

NOTES

--- FIELD WIRING

INTERNAL WIRING

TERMINAL IN PANEL

TERMINAL IN PANEL AND REMOTE

DRAWING SHOWN DE-ENERGIZED.

WIRE COLOR

BK	- BLACK	YW	- YELLOW
BL	- BLUE	GR	- GREEN
BR	- BROWN	GY	- GRAY
OR	- ORANGE	OR/BL	- ORANGE/BLUE (STRIPE)
RD	- RED	BL/RD	- BLUE/RED (STRIPE)
WH	- WHITE	BL/RD	- BLUE/RED (STRIPE)
PR	- PURPLE	RD/GN	- RED/GREEN (STRIPE)
PK	- PINK		

HOOD LIGHTS TO CONTROL PANEL

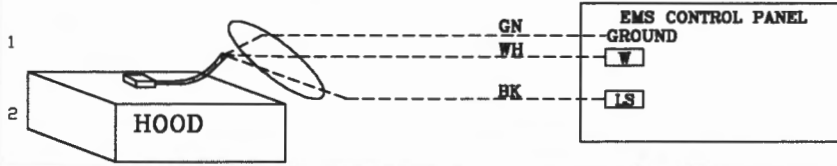

TEMPERATURE SENSOR WIRING (IF FIELD INSTALLED)

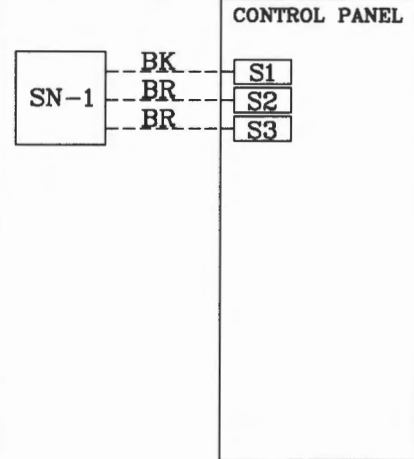

POWER FEED FOR CONTROLS AND LIGHTING

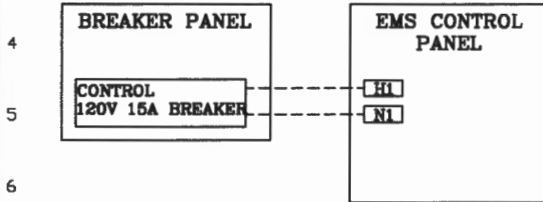

DDC, BUILDING MANAGEMENT OR RTU INTERFACE CONTROL PANEL

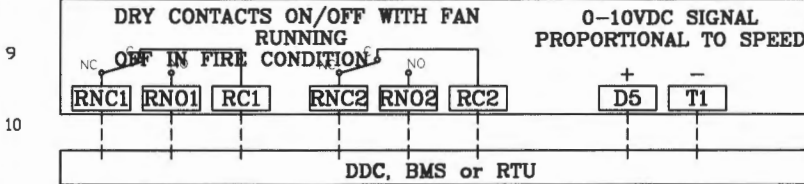

FIRE SYSTEM MICROSWITCH WIRING TO CONTROL PANEL 120VAC SHUNT TRIP BREAKER WIRING

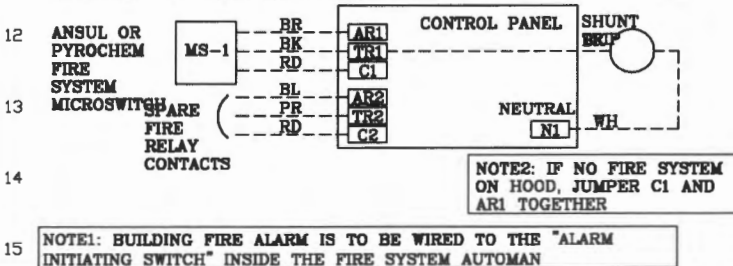

MICRO-SWITCHES WIRING WHEN MULTIPLE FIRE SYSTEMS CONNECTED TO ONE EMS PANEL (3 SHOWN HERE)

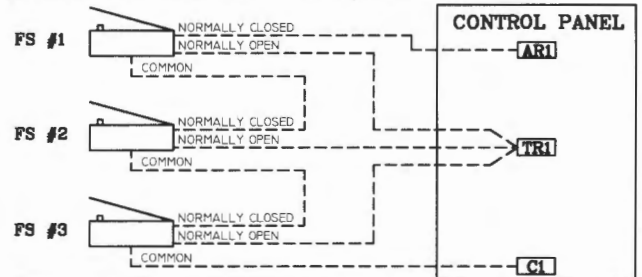

FAN WIRING TO CONTROL PANEL

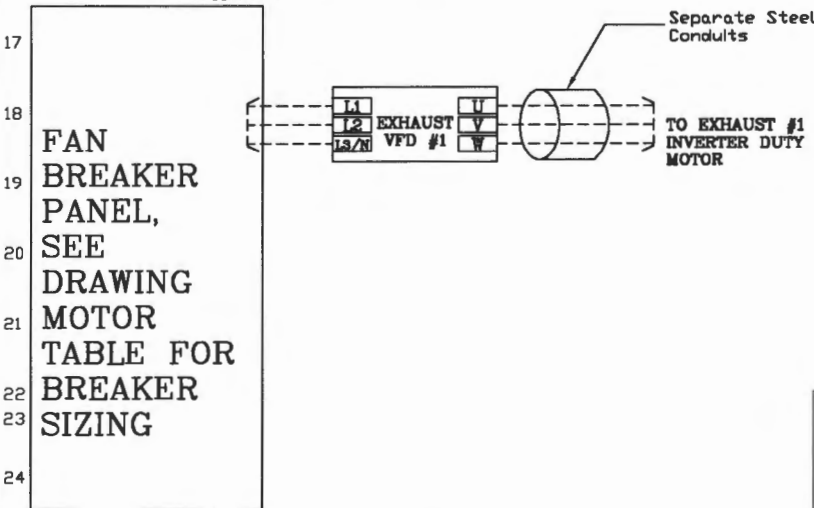

ELECTRIC GAS VALVE WITH RESET RELAY

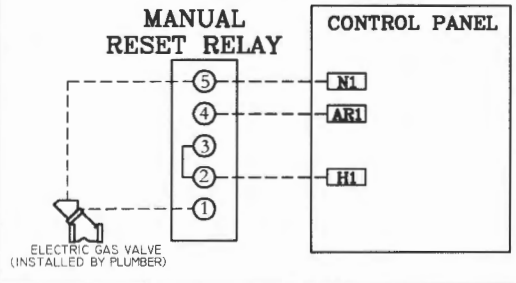

NOTES

----- DENOTES FIELD WIRING
 ----- DENOTES INTERNAL WIRING

WIRE COLOR

BK - BLACK YW - YELLOW
 BL - BLUE GY - GRAY
 BR - BROWN PR - PURPLE
 OR - ORANGE OR/BL - ORANGE/BLUE (STRIPE)
 RD - RED BL/RD - BLUE/RED (STRIPE)
 WH - WHITE BL/GN - BLUE/GREEN (STRIPE)
 GN - GREEN RD/GN - RED/GREEN (STRIPE)

NOTE:
 3 PHASE INPUT, USE L1, L2, L3.
 1 PHASE 240 VAC INPUT, USE L1 & L2 ONLY.
 1 PHASE 120 VAC INPUT, USE L1 & N ONLY.