

PERMIT ISSUED

City of Portland, Maine - Building or Use Permit Application
 389 Congress Street, 04101 Tel: (207) 874-8703, Fax: (207) 874-8716

| | | |
|-----------------------|-----------------------------------|---------------------|
| Permit No: 03-1069 | Issue Date: SEP 04 2003 | CBL: 156 A017001 |
|-----------------------|-----------------------------------|---------------------|

| | | | |
|--|---|--|-----------------------------|
| Location of Construction: 24 Read St | Owner Name: Warn Elizabeth K | Owner Address: 28 Read St CITY OF PORTLAND | Phone: 879-0746 |
| Business Name: | Contractor Name: Allan Knight | Contractor Address: 2079 Durham Road Guilford | Phone: 2034570182 |
| Lessee/Buyer's Name | Phone: | Permit Type: Amendment to Single Family | Zone: R3 |

| | | | | |
|-----------------------------------|---|-------------------------------|------------------------------------|---------------------------|
| Past Use: Single Family | Proposed Use: Single Family w/amendment to #03-0731 | Permit Fee: \$57.00 | Cost of Work: \$4,000.00 | CEO District: 2 |
|-----------------------------------|---|-------------------------------|------------------------------------|---------------------------|

| | | |
|---|---|--|
| Proposed Project Description: Add 2nd story to rear addition of original permit 03-0731 and exterior stairs | FIRE DEPT: <input type="checkbox"/> Approved <input type="checkbox"/> Denied | INSPECTION: Use Group: R3 Type: SB BOCA 1999 |
| Signature: | Signature: <i>JMB 9/4/03</i> | |

| | | | |
|--------------------------------|--|------------------------|--|
| Permit Taken By: jmb | Date Applied For: 09/04/2003 | Zoning Approval | |
|--------------------------------|--|------------------------|--|

| | | | |
|---|---|---|---|
| <ol style="list-style-type: none"> This permit application does not preclude the Applicant(s) from meeting applicable State and Federal Rules. Building permits do not include plumbing, septic or electrical work. Building permits are void if work is not started within six (6) months of the date of issuance. False information may invalidate a building permit and stop all work.. | Special Zone or Reviews <input type="checkbox"/> Shoreland <input type="checkbox"/> Wetland <input type="checkbox"/> Flood Zone <input type="checkbox"/> Subdivision <input type="checkbox"/> Site Plan Maj <input type="checkbox"/> Minor <input type="checkbox"/> MM <input type="checkbox"/> Date: <i>JMB 9/4/03</i> | Zoning Appeal <input type="checkbox"/> Variance <input type="checkbox"/> Miscellaneous <input type="checkbox"/> Conditional Use <input type="checkbox"/> Interpretation <input type="checkbox"/> Approved <input type="checkbox"/> Denied Date: | Historic Preservation <input checked="" type="checkbox"/> Not in District or Landmark <input type="checkbox"/> Does Not Require Review <input type="checkbox"/> Requires Review <input type="checkbox"/> Approved <input type="checkbox"/> Approved w/Conditions <input type="checkbox"/> Denied Date: <i>JMB</i> |
| | <i>Approved orig permit # 03-0731</i> | | |

CERTIFICATION

I hereby certify that I am the owner of record of the named property, or that the proposed work is authorized by the owner of record and that I have been authorized by the owner to make this application as his authorized agent and I agree to conform to all applicable laws of this jurisdiction. In addition, if a permit for work described in the application is issued, I certify that the code official's authorized representative shall have the authority to enter all areas covered by such permit at any reasonable hour to enforce the provision of the code(s) applicable to such permit.

| | | | |
|---|---------|------|-------|
| SIGNATURE OF APPLICANT | ADDRESS | DATE | PHONE |
| RESPONSIBLE PERSON IN CHARGE OF WORK, TITLE | | DATE | PHONE |

City of Portland, Maine - Building or Use Permit

389 Congress Street, 04101 Tel: (207) 874-8703, Fax: (207) 874-8716

| | | |
|------------------------------|--|----------------------------|
| Permit No: 03-1069 | Date Applied For: 09/04/2003 | CBL: 156 A017001 |
|------------------------------|--|----------------------------|

| | | | |
|--|---|---|---------------------------------|
| Location of Construction: 24 Read St | Owner Name: Warn Elizabeth K | Owner Address: 28 Read St | Phone: () 879-0746 |
| Business Name: | Contractor Name: Allan Knight | Contractor Address: 2079 Durham Road Guilford | Phone: (203) 457-0182 |
| Lessee/Buyer's Name | Phone: | Permit Type: Amendment to Single Family | |

| | |
|---|---|
| Proposed Use: Single Family w/amendment to #03-0731 | Proposed Project Description: Add 2nd story to rear addition of original permit 03-0731 and exterior stairs |
|---|---|

Dept: Zoning **Status:** Approved **Reviewer:** Jeanine Bourke **Approval Date:** 09/04/2003

Note: **Ok to Issue:**

- 1) This approves the 2nd story addition to the rear structure only
- 2) This property shall remain a single family dwelling. Any change of use shall require a separate permit application for review and approval.

Dept: Building **Status:** Approved **Reviewer:** Jeanine Bourke **Approval Date:** 09/04/2003

Note: **Ok to Issue:**

All Purpose Building Permit Application

If you or the property owner owes real estate or personal property taxes or user charges on any property within the City, payment arrangements must be made before permits of any kind are accepted.

| | | |
|--|--|---|
| Location/Address of Construction: <u>28 Reed St</u> | | |
| Total Square Footage of Proposed Structure <u>Intel 288/576</u> | Square Footage of Lot <u>5250</u> | |
| Tax Assessor's Chart, Block & Lot Chart# <u>156</u> Block# <u>A</u> Lot# <u>17/18</u> | Owner: <u>Richard & Elizabeth Warr</u> | Telephone: <u>207 879-0746</u> |
| Lessee/Buyer's Name (if Applicable) | Applicant name, address & telephone: <u>Allan Knight</u> <u>28 Reed St</u> <u>Portland Me</u> | Cost Of Work: \$ <u>400</u> Fee: \$ <u>51.00</u> |
| Current use: <u>SFR</u> | | |
| If the location is currently vacant, what was prior use: _____ | | |
| Approximately how long has it been vacant: _____ | | |
| Proposed use: <u>SFR</u> | | |
| Project description: <u>Amend permit # -03-0731</u> <u>add 2nd story</u> | | |
| Contractor's name, address & telephone: | | |
| Who should we contact when the permit is ready: <u>Allan Knight 207 879 0746</u> | | |
| Mailing address: | | |
| We will contact you by phone when the permit is ready. You must come in and pick up the permit and review the requirements before starting any work, with a Plan Reviewer. A stop work order will be issued and a \$100.00 fee if any work starts before the permit is picked up. PHONE: | | |

IF THE REQUIRED INFORMATION IS NOT INCLUDED IN THE SUBMISSIONS THE PERMIT WILL BE AUTOMATICALLY DENIED AT THE DISCRETION OF THE BUILDING/PLANNING DEPARTMENT, WE MAY REQUIRE ADDITIONAL INFORMATION IN ORDER TO APPROVE THIS PERMIT.

I hereby certify that I am the Owner of record of the named property, or that the owner of record authorizes the proposed work and that I have been authorized by the owner to make this application as his/her authorized agent. I agree to conform to all applicable laws of this jurisdiction. In addition, if a permit for work described in this application is issued, I certify that the Code Official's authorized representative shall have the authority to enter all areas covered by this permit at any reasonable hour to enforce the provisions of the codes applicable to this permit.

| | |
|---|---------------------|
| Signature of applicant: <u>Allan R Knight</u> | Date: <u>8/8/03</u> |
|---|---------------------|

**This is NOT a permit, you may not commence ANY work until the permit is issued.
If you are in a Historic District you may be subject to additional permitting and fees with the Planning Department on the 4th floor of City Hall**

R-3

R-3
Sides - 8'
Front + Rear - 25'
Lot cov - 25% - OK

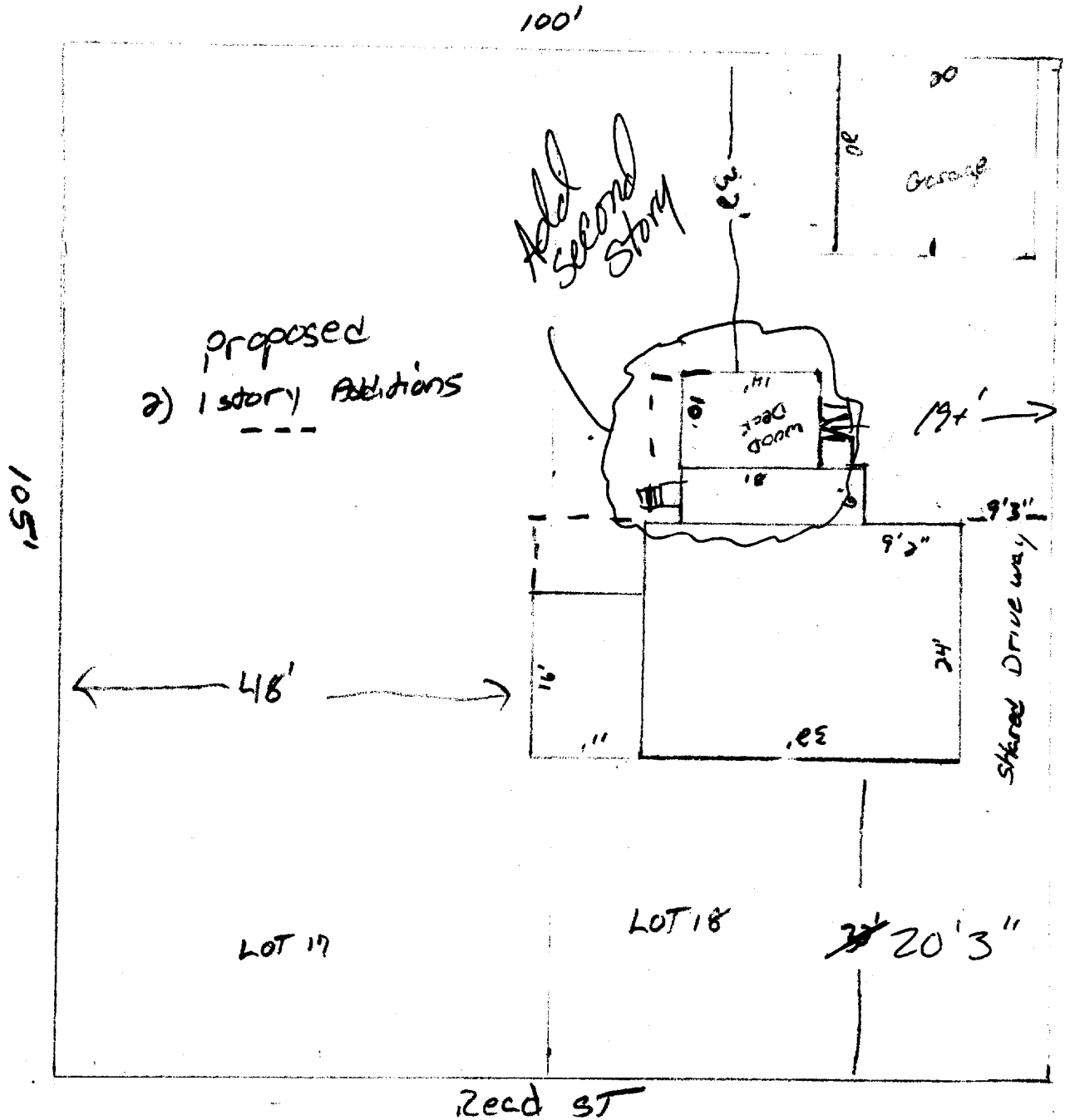

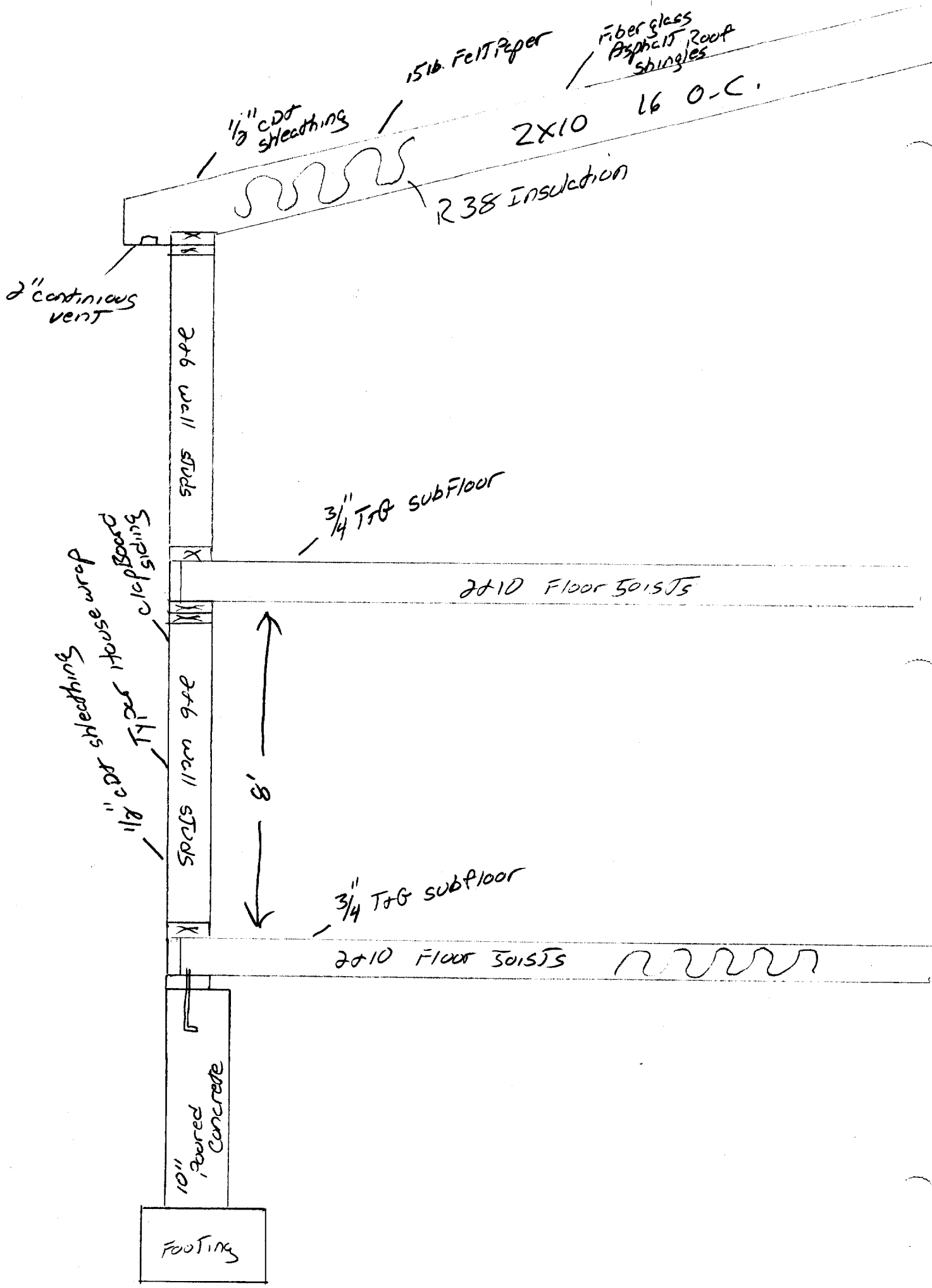

1st Floor

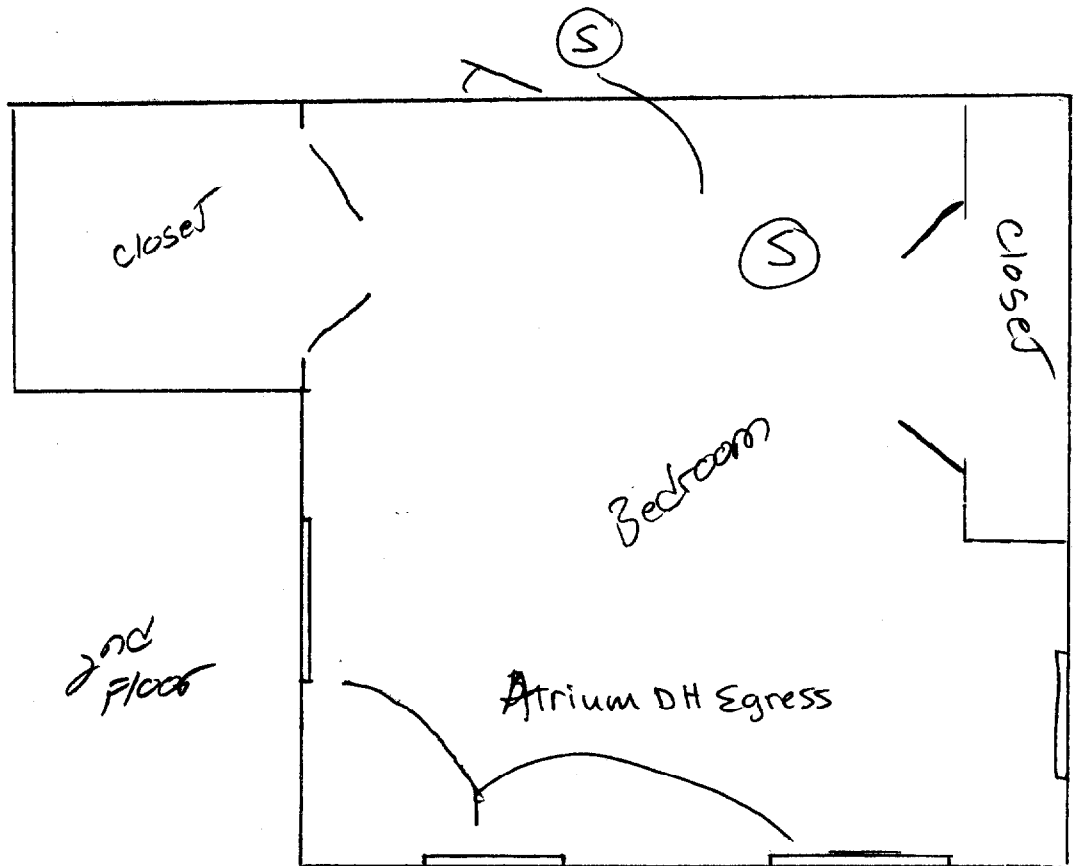
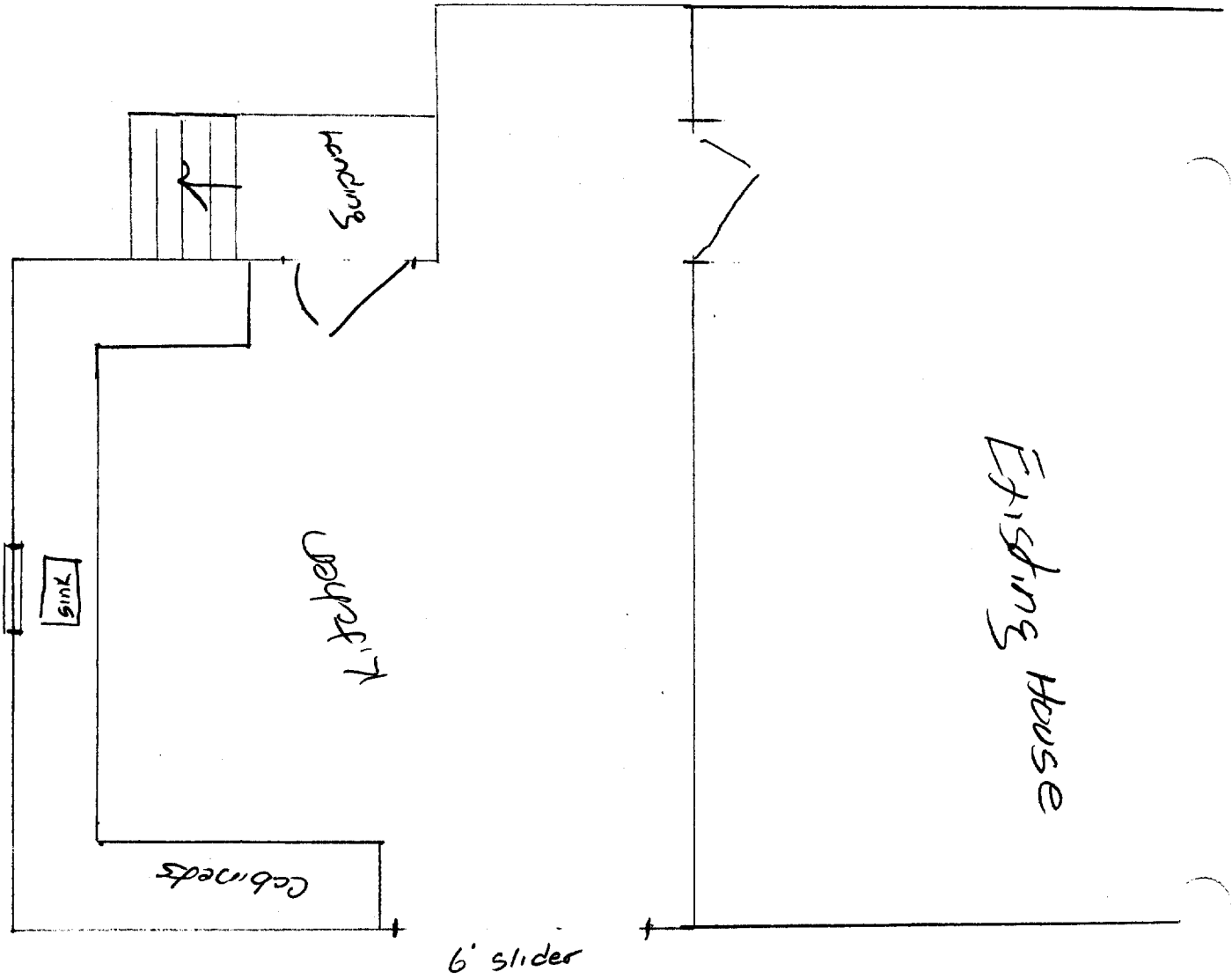

Typical
Exterior stairs
w/ 36" railing/pickets 5" oc

One side graspable HR
@ 34-38" w/ returns

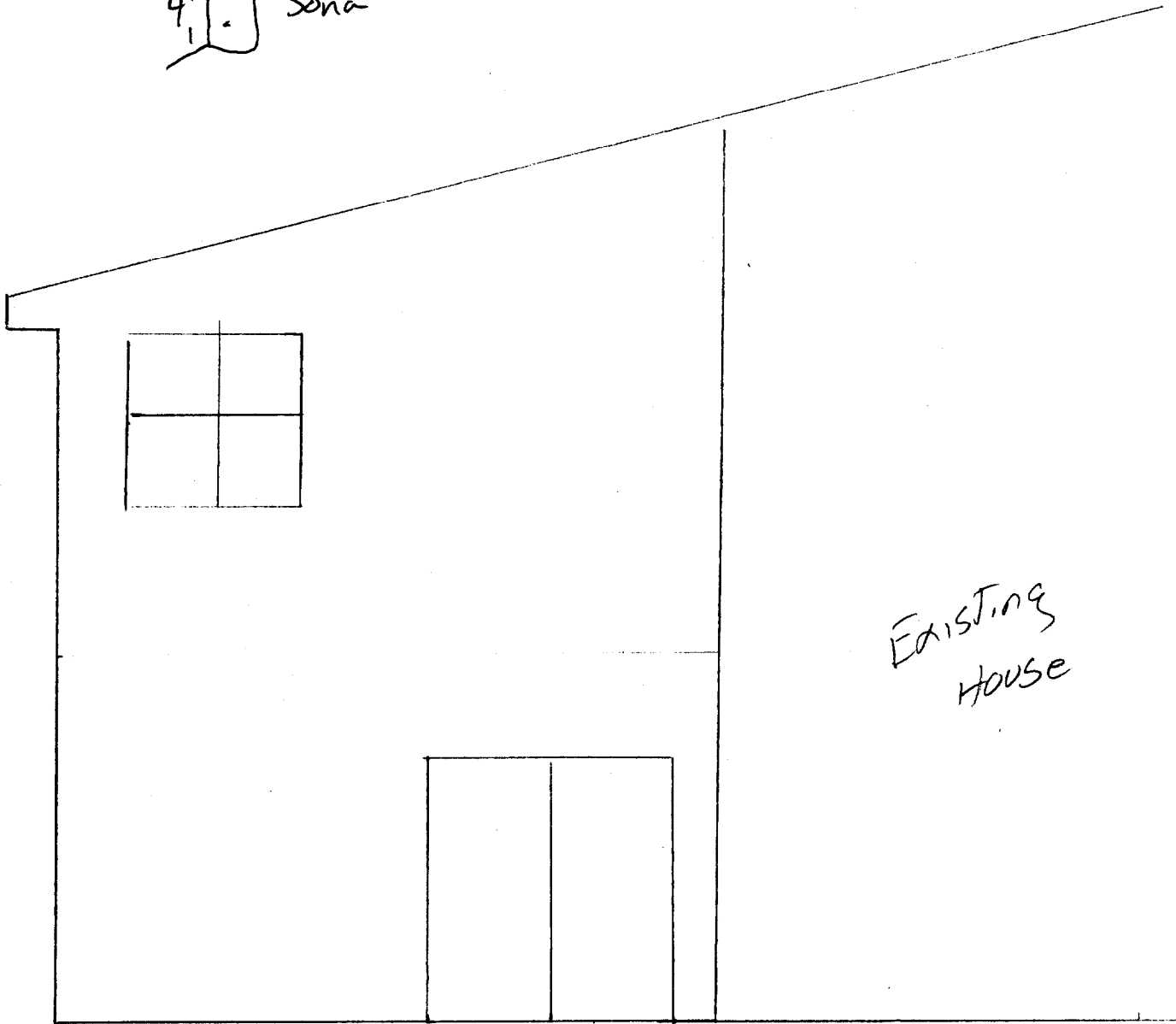
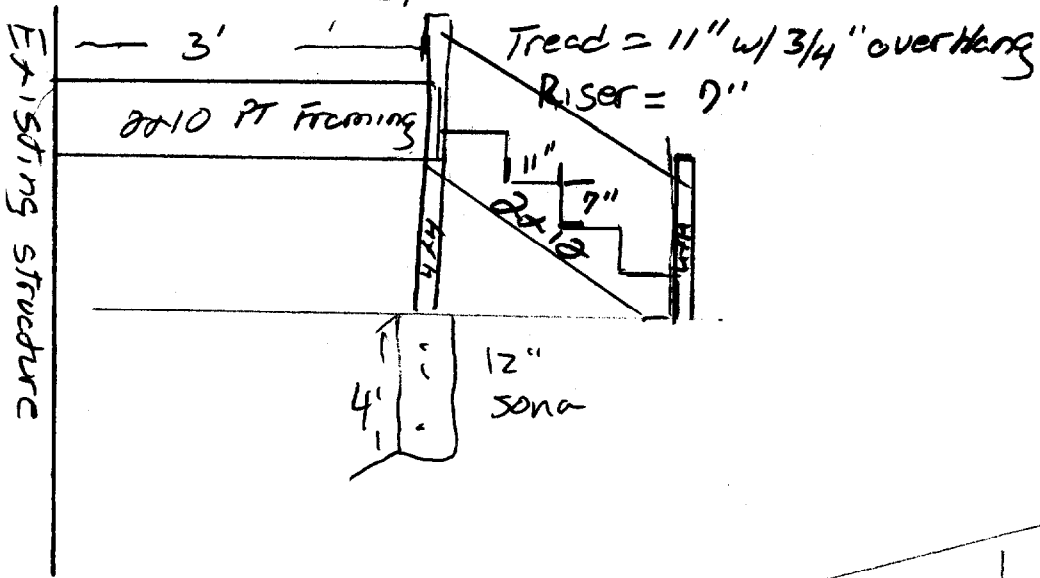

BUILDING PERMIT INSPECTION PROCEDURES

Please call 874-8703 or ~~874-8693~~ to schedule your inspections as agreed upon

Permits expire in 6 months, if the project is not started or ceases for 6 months.

The Owner or their designee is required to notify the inspections office for the following inspections and provide adequate notice. Notice must be called in 48-72 hours in advance in order to schedule an inspection:

By initializing at each inspection time, you are agreeing that you understand the inspection procedure and additional fees from a "Stop Work Order" and "Stop Work Order Release" will be incurred if the procedure is not followed as stated below.

JB **Pre-construction Meeting:** Must be scheduled with your inspection team upon receipt of this permit. Jay Reynolds, Development Review Coordinator at ~~874-8632~~ must also be contacted at this time, before any site work begins on any project other than single family additions or alterations.

- Footing/Building Location Inspection:** Prior to pouring concrete
- NA **Re-Bar Schedule Inspection:** Prior to pouring concrete
- NA **Foundation Inspection:** Prior to placing ANY backfill
- Framing/Rough Plumbing/Electrical:** Prior to any insulating or drywalling
- Final/Certificate-of-Occupancy:** Prior to any occupancy of the structure or use. ~~NOTE: There is a \$75.00 fee per inspection at this point.~~

Certificate of Occupancy is not required for certain projects. Your inspector can advise you if your project requires a Certificate of Occupancy. All projects DO require a final inspection

If any of the inspections do not occur, the project cannot go on to the next phase, REGARDLESS OF THE NOTICE OR CIRCUMSTANCES.

NA **CERTIFICATE OF OCCUPANCIES MUST BE ISSUED AND PAID FOR, BEFORE THE SPACE MAY BE OCCUPIED**

Skip Knight
Signature of applicant/designee

9/4/03
Date

Leanne Banks
Signature of Inspections Official

9/4/03
Date

CBL: 156-A-17 Building Permit #

03-1069

DISPLAY THIS CARD ON PRINCIPAL FRONTAGE OF WORK
CITY OF PORTLAND

Please Read Application And Notes, If Any, Attached

BUILDING INSPECTION

PERMIT ISSUED

Permit Number: 031069
SEP 04 2003

This is to certify that Warn Elizabeth K/Allan Kn
has permission to Add 2nd story to rear addition of original permit 030731 and exterior stairs
AT 24 Read St 156 A017001

provided that the person or persons, firm or corporation accepting this permit shall comply with all of the provisions of the Statutes of Maine and of the Ordinances of the City of Portland regulating the construction, maintenance and use of buildings and structures, and of the application on file in this department.

Apply to Public Works for street line and grade if nature of work requires such information.

Notification of inspection must be given and when permission is procured before this building or part thereof is occupied or closed-in. **HEAR NOTICE IS REQUIRED.**

A certificate of occupancy must be procured by owner before this building or part thereof is occupied.

OTHER REQUIRED APPROVALS

Fire Dept. _____
Health Dept. _____
Appeal Board _____
Other _____
Department Name

Jamie Bouke 9/4/03
Director - Building & Inspection Services

PENALTY FOR REMOVING THIS CARD