

NOTES:
1. PROVIDE (3)-2x6 COLUMNS, U.N.O.

PARTIAL CEILING PLAN

SCALE: 1/4"=1'-0"

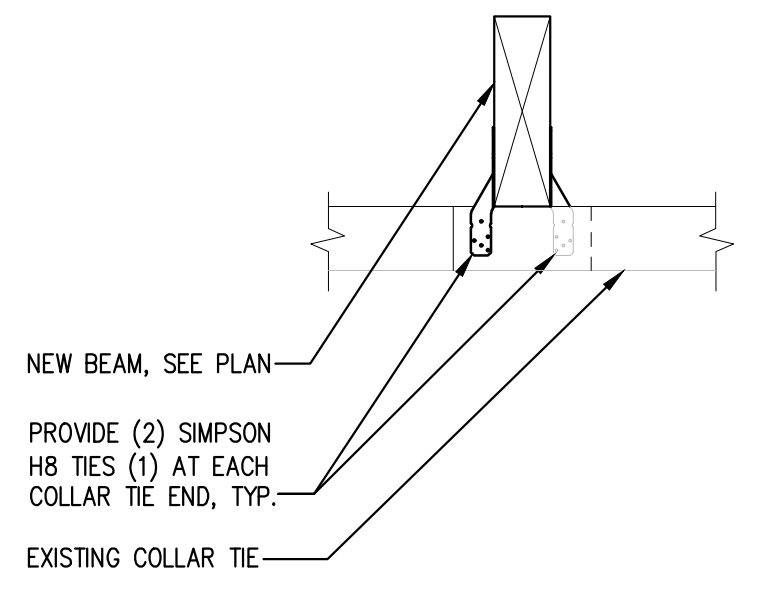

1 SECTION
1" = 1'-0"

GENERAL NOTES:

1. REFERENCE ARCHITECTURAL PLANS FOR DIMENSIONS NOT SHOWN. REFERENCE MECHANICAL, ELECTRICAL, AND ARCHITECTURAL PLANS FOR SIZES AND LOCATIONS OF WALL AND SLAB OPENINGS, DUCTS, PIPING, CURBS, AND EQUIPMENT PADS. IN THE EVENT OF A CONFLICT BETWEEN THE DRAWINGS, SPECIFICATIONS, OR NOTES ON THE DRAWINGS, THE ENGINEER SHALL BE NOTIFIED PRIOR TO CONSTRUCTION.
2. EXISTING DIMENSIONS AND CONDITIONS ARE FOR REFERENCE ONLY. CONTRACTOR SHALL VERIFY ALL EXISTING CONSTRUCTION AND DIMENSIONS IN THE FIELD PRIOR TO CONSTRUCTION OR FABRICATION. ALL DISCREPANCIES SHALL BE REPORTED TO THE ENGINEER PRIOR TO COMMENCING WORK.
3. THE CONTRACTOR SHALL NOTIFY THE ENGINEER IF DEVIATIONS OR CHANGES ARE REQUIRED TO THE CONTRACT DOCUMENTS OR APPROVED SHOP DRAWINGS DUE TO INTERFERENCES, FABRICATION ERRORS, OR OTHER CAUSES.
4. THE STRUCTURE IS SELF-SUPPORTING AND STABLE AFTER THE ENTIRE BUILDING IS COMPLETELY CONSTRUCTED. THE CONTRACTOR IS SOLELY RESPONSIBLE FOR ERECTION PROCEDURES AND SEQUENCING DURING CONSTRUCTION AND ERECTION TO PROVIDE AND ENSURE LOCAL AND OVERALL STABILITY OF THE BUILDING AND ITS COMPONENTS DURING CONSTRUCTION AND ERECTION. THE CONTRACTOR SHALL RETAIN A LICENSED STRUCTURAL ENGINEER TO DESIGN TEMPORARY BRACING/SHORING AND DETERMINE WHERE THE TEMPORARY BRACING/SHORING IS NEEDED.
5. THE CONTRACTOR SHALL BE RESPONSIBLE FOR ERECTION PROCEDURES, SEQUENCING AND FOR COMPLYING WITH ALL APPLICABLE SAFETY REGULATIONS DURING THE WORK.
6. ONE ELECTRONIC COPY OR TWO SETS OF HARD COPIES OF SHOP DRAWINGS SHALL BE SUBMITTED TO THE ENGINEER. ONE HARD COPY WILL BE RETURNED TO THE CONTRACTOR AND ONE HARD COPY WILL BE RETAINED BY THE ENGINEER.
7. REFERENCE THE PROJECT SPECIFICATIONS FOR MATERIAL, WORKMANSHIP AND ADDITIONAL INFORMATION NOT COVERED IN THESE NOTES (WHERE APPLICABLE)

WOOD NOTES:

1. ALL TIMBER FRAMING SHALL BE IN ACCORDANCE WITH IBC 2009 REFERENCED EDITIONS OF THE AITC TIMBER CONSTRUCTION MANUAL AND AF&PA NATIONAL DESIGN SPECIFICATION FOR WOOD CONSTRUCTION (NDS).
2. ALL FRAMING SHALL BE SPRUCE-PINE-FIR, No.2 OR BETTER U.N.O. AND HAVE A MAXIMUM MOISTURE CONTENT OF 19%.
3. ALL WOOD IN CONTACT WITH MASONRY OR CONCRETE OR EXPOSED TO WEATHER SHALL BE PRESSURE TREATED (PT) SOUTHERN YELLOW PINE.
4. WHERE "LVL" IS NOTED ON DRAWINGS, PROVIDE LAMINATED VENEER LUMBER, WHICH HAS THE FOLLOWING MINIMUM ALLOWABLE STRESSES:
Fb = 2600 PSI Fc = 2510 PSI (PARALLEL TO GRAIN)
Fv = 285 PSI Fc = 750 PSI (PERPENDICULAR TO GRAIN)
Ft = 1555 PSI E = 2,000,000 PSI
5. WHERE "PSL" IS NOTED ON DRAWINGS, PROVIDE PARALLAM STRAND LUMBER, WHICH HAS THE FOLLOWING MINIMUM ALLOWABLE STRESSES:
Fb = 2900 PSI Fc = 2900 PSI (PARALLEL TO GRAIN)
Fv = 290 PSI Fc = 750 PSI (PERPENDICULAR TO GRAIN)
Ft = 2025 PSI E = 2,000,000 PSI
6. ALL ENGINEERED LUMBER THAT IS EXPOSED TO WEATHER SHALL BE WOLMANIZED.
7. ALL FLOOR SHEATHING SHALL BE 3/4" TONGUE AND GROOVE, GLUED AND NAILED TO FLOOR FRAMING WITH 8d RINK SHANK NAILS AT 6" o.c. AT SUPPORTED PANEL EDGES, 12" o.c. AT INTERMEDIATE SUPPORTS UNLESS NOTED OTHERWISE ON DRAWINGS.
8. ALL ROOF SHEATHING (5/8") AND WALL SHEATHING (1/2") SHALL BE APA PERFORMANCE-RATED. ATTACH TO SUPPORTED PANEL EDGES WITH 8d NAILS AT 6" o.c. AND AT INTERMEDIATE SUPPORTS WITH 8d NAILS AT 12" o.c. U.N.O. SEE DRAWINGS FOR MORE STRINGENT NAILING REQUIREMENTS AT WOOD SHEAR WALLS.
9. SHEATHING SHALL BE ORIENTED WITH LONG DIMENSION PERPENDICULAR TO THE SUPPORTS AND BE CONTINUOUS OVER TWO OR MORE SUPPORTS. STAGGER ALL JOINTS & PROVIDE ADEQUATE JOINT SPACING (1/8" TYP) AS RECOMMENDED BY MANUFACTURER.
10. PROVIDE FULL DEPTH BLOCKING AT ENDS AND INTERIOR SUPPORTS OF ALL JOISTS AND RAFTERS WHERE JOISTS AND RAFTERS FRAME OVER SUPPORTS. PROVIDE 1x3 DIAGONAL BRIDGING OR FULL DEPTH SOLID BLOCKING FOR EACH 8'-0" OF SPAN FOR ALL JOISTS AND RAFTERS.
11. WHERE BEAMS ARE LABELED ON PLAN, DO NOT SPLICE BEAM NOR ANY PLY OF BEAM BETWEEN SUPPORTS.
12. ALL CONNECTION HARDWARE SHALL BE BY SIMPSON STONG-TIE (OR APPROVED EQUIVALENT) AND SHALL BE HOP-DIPPED GALVANIZED. HARDWARE IN CONTACT WITH PRESSURE TREATED (PT) LUMBER SHALL BE GALVANIZED G185 (ZMAX). REFER TO MANUFACTURERS LITERATURE FOR PROPER INSTALLATION GUIDELINES.
13. FASTENERS USED IN CONTACT WITH PRESSURE TREATED (PT) LUMBER SHALL BE HOT-DIPPED GALVANIZED, STAINLESS STEEL, OR OTHER FINISH APPROVED BY ENGINEER.
14. ALIGN COLUMNS SUCH THAT COLUMNS BEAR CONTINUOUSLY TO FOUNDATION SUPPORT. INSTALL ADDITIONAL SOLID BLOCKING WITHIN FLOOR PACKAGE TO PROVIDE CONTINUITY OF LOAD PATH.
15. PROVIDE HORIZONTAL BLOCKING FOR ALL LOAD BEARING WALLS AT 4'-0" O.C. VERTICAL, MAXIMUM.
16. SUBMIT SHOP DRAWINGS FOR ALL PREFABRICATED WOOD JOISTS AND WALL PANELS TO ENGINEER FOR REVIEW PRIOR TO CONSTRUCTION.

PLAN LEGEND

- BEARING WALL
- SHEAR WALL
- BEAM
- HSS COLUMN
- COLUMN FROM ABOVE
- COLUMN BELOW
- COLUMN ABOVE AND BELOW
- HOLD-DOWN

CASCO BAY ENGINEERING
424 Fore Street
Portland, ME 04101
Phone 207.842.2800
Fax 207.842.2828
www.cascobayengineering.com

CLIENT:
KATELYNN FISHER
56 BAY ST.
PORTLAND, ME 04103

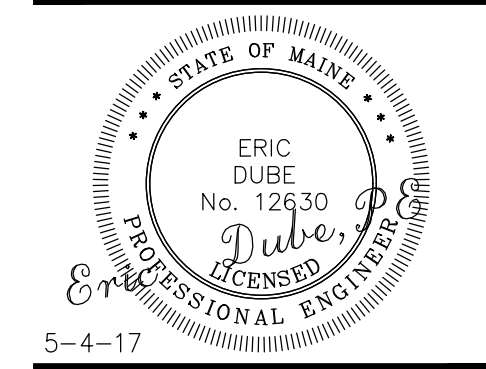

56 BAY STREET
56 BAY STREET PORTLAND ME, 04103

PROPOSED REMODEL

No.	DESCRIPTION	DR.	CHK.	DATE	
				BY	ED
0	ISSUED FOR CONSTRUCTION	CD	ED	5-4-17	

SHEET TITLE:

PARTIAL CEILING PLAN

DESIGNED: ED
DRAWN: CD
DATE: 5-4-17
PROJECT NUMBER: 17-068

S1.0

PRINTED: May 11, 2017