

City of Portland, Maine - Building or Use Permit Application

389 Congress Street, 04101 Tel: (207) 874-8703, Fax: (207) 874-8716

Permit No: 04-009#	Issue Date: PERMIT ISSUED FEB 06 2004	CBL: 153 A025007
-----------------------	--	---------------------

Location of Construction: 33 Kimberly Ct	Owner Name: Nial Construction Inc	Owner Address: 191 State Rd Ste # 2	Phone:
Business Name:	Contractor Name: Pine State Plumbing & Heating	Contractor Address: PO Box 6308 Scarborough	Phone: 2078831200
Lessee/Buyer's Name	Phone:	Permit Type: HVAC	Zone: R3

Past Use: Condo (unit 7) in 4 unit bldg.	Proposed Use: Condo/ Install a Majestic direct vent gas Fireplace	Permit Fee: \$30.00	Cost of Work: \$1,000.00	CEO District: 4
Proposed Project Description: Condo/ Install a Majestic direct vent gas Fireplace		FIRE DEPT: <input checked="" type="checkbox"/> Approved <input type="checkbox"/> Denied	INSPECTION: Use Group: Heating Type: Heating	

Signature: <i>[Signature]</i>	Signature: <i>[Signature]</i>
PEDESTRIAN ACTIVITIES DISTRICT (P.A.D.)	
Action: <input type="checkbox"/> Approved <input type="checkbox"/> Approved w/Conditions <input type="checkbox"/> Denied	
Signature:	Date:

Permit Taken By: Idobson	Date Applied For: 02/03/2004	Zoning Approval	
------------------------------------	--	------------------------	--

<ol style="list-style-type: none"> This permit application does not preclude the Applicant(s) from meeting applicable State and Federal Rules. Building permits do not include plumbing, septic or electrical work. Building permits are void if work is not started within six (6) months of the date of issuance. False information may invalidate a building permit and stop all work.. 	Special Zone or Reviews <input type="checkbox"/> Shoreland <input type="checkbox"/> Wetland <input type="checkbox"/> Flood Zone <input type="checkbox"/> Subdivision <input type="checkbox"/> Site Plan Maj <input type="checkbox"/> Minor <input checked="" type="checkbox"/> MMJ Date: <i>2/3/04</i>	Zoning Appeal <input type="checkbox"/> Variance <input type="checkbox"/> Miscellaneous <input type="checkbox"/> Conditional Use <input type="checkbox"/> Interpretation <input type="checkbox"/> Approved <input type="checkbox"/> Denied Date:	Historic Preservation <input checked="" type="checkbox"/> Not in District or Landmark <input type="checkbox"/> Does Not Require Review <input type="checkbox"/> Requires Review <input type="checkbox"/> Approved <input type="checkbox"/> Approved w/Conditions <input type="checkbox"/> Denied Date:
---	--	---	--

CERTIFICATION

I hereby certify that I am the owner of record of the named property, or that the proposed work is authorized by the owner of record and that I have been authorized by the owner to make this application as his authorized agent and I agree to conform to all applicable laws of this jurisdiction. In addition, if a permit for work described in the application is issued, I certify that the code official's authorized representative shall have the authority to enter all areas covered by such permit at any reasonable hour to enforce the provision of the code(s) applicable to such permit.

SIGNATURE OF APPLICANT _____ ADDRESS _____ DATE _____ PHONE _____

RESPONSIBLE PERSON IN CHARGE OF WORK, TITLE _____ DATE _____ PHONE _____

153A 025007



FILL IN AND SIGN WITH INK

APPLICATION FOR PERMIT HEATING OR POWER EQUIPMENT

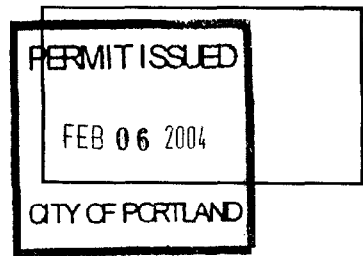

To the INSPECTOR OF BUILDINGS, PORTLAND, ME.

The undersigned hereby applies for a permit to install the following heating, cooking or power equipment in accordance with the Laws of Maine, the Building Code of the City of Portland, and the following specifications:

Location / CBL 33 Kimberly Court Use of Building Residence Date 2/2/04
Name and address of owner of appliance Larry Sturdivant

Installer's name and address Pine State Plumbing + Heating
5 Industry Rd. So. Portland, Me 04106 Telephone 321-2261

Location of appliance:

- Basement
- Floor
- Attic
- Roof

Type of Fuel:

- Gas
- Oil
- Solid

Appliance Name: Majestic direct vent fireplace

U.L. Approved Yes No

Will appliance be installed in accordance with the manufacture's installation instructions? Yes No

IF NO Explain: _____

The Type of License of Installer:

- Master Plumber # _____
- Solid Fuel # _____
- Oil # _____
- Gas # PNT 552
- Other _____

Type of Chimney:

Masonry Lined
Factory built _____

Metal
Factory Built U.L. Listing # _____

Direct Vent
Type _____ UL# _____

Type of Fuel Tank

- Oil
- Gas

Size of Tank _____

Number of Tanks _____

Distance from Tank to Center of Flame _____ feet.

Cost of Work: \$ 1000.00

Permit Fee: \$ _____

Approved

Approved with Conditions

Fire: [Signature]
Ele.: _____
Bldg.: _____

See attached letter or requirement

Inspector's Signature

Date Approved

Signature of Installer [Signature]

MAJESTIC.[®] *Fireplaces*



*Rear Vented
Direct Vent
Models*

**DVR33
DVR36
DVR39**

Installation Instructions & Homeowner's Manual

WARNING! IF THE INFORMATION IN THIS MANUAL IS NOT FOLLOWED EXACTLY, A FIRE OR EXPLOSION MAY RESULT CAUSING PROPERTY DAMAGE, PERSONAL INJURY OR LOSS OF LIFE.

FOR YOUR SAFETY

WHAT TO DO IF YOU SMELL GAS:

- * Do not try to light any appliance.
- * Do not touch any electric switch
- * Do not use any phone in your building.
- * Immediately call your gas supplier from your neighbours phone. Follow the gas suppliers instructions.
- * If you cannot reach your gas supplier call the fire department.

FOR YOUR SAFETY

DO NOT STORE
OR USE GASOLINE OR OTHER
FLAMMABLE VAPOURS AND LIQUIDS
IN THE VICINITY OF THIS OR ANY
OTHER APPLIANCE.

- * Installation and service must be performed by a qualified installer, service agency or your gas supplier.



THE CPMA
MAJESTIC
PRODUCTS COMPANY
475 Admiral Blvd.
Mississauga, Ontario, Canada
L5T 2N1

THE
MAJESTIC
PRODUCTS COMPANY
1000 East Market Street
Huntington, Indiana, U.S.A.
46750



INSTALLER: DO NOT DISCARD THIS MANUAL - LEAVE FOR HOMEOWNER

10001029
10/98 Rev. 0

FIREPLACE DIMENSIONS

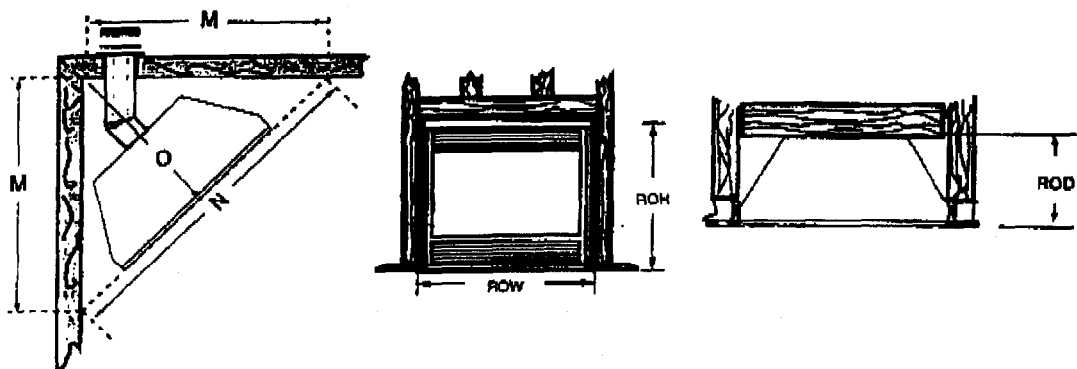

FRAMING & FINISHING

MODEL DVR33

A	33"	838mm
B	28 ⁷ / ₈ "	733mm
C	16 ³ / ₈ "	416mm
D	31"	787mm
E	22 ¹ / ₁₆ "	560mm
F	11 ¹ / ₂ "	292mm
G	14 ³ / ₄ "	375mm
H	15 ⁵ / ₈ "	397mm
I	19 ¹ / ₄ "	489mm
J	5"	127mm
K	7 ¹ / ₂ "	191mm
L	8 ¹ / ₂ "	216mm
M	36"	914mm
N	51"	1295mm
O	25 ¹ / ₂ "	648mm
ROD	12"	305mm
ROW	33 ¹ / ₂ "	851mm
ROH	29"	737mm

Table 1

MODEL DVR36

A	36"	914mm
B	34 ¹ / ₄ "	870mm
C	21"	533mm
D	33"	838mm
E	20"	508mm
F	14"	356mm
G	17"	432mm
H	18 ¹ / ₂ "	470mm
I	22 ¹ / ₄ "	565mm
J	5 ¹ / ₄ "	132mm
K	7 ³ / ₄ "	197mm
L	10 ³ / ₄ "	273mm
M	40"	1016mm
N	56"	1422mm
O	28 ⁵ / ₈ "	727mm
ROD	14 ¹ / ₂ "	368mm
ROW	36 ¹ / ₂ "	927mm
ROH	34 ³ / ₄ "	883mm

Table 2

MODEL DVR39

A	39"	991mm
B	34 ¹ / ₄ "	870mm
C	21"	533mm
D	36"	914mm
E	24"	610mm
F	16"	406mm
G	19"	483mm
H	18 ¹ / ₂ "	470mm
I	22 ¹ / ₄ "	565mm
J	6"	152mm
K	8"	203mm
L	12 ¹ / ₂ "	318mm
M	44"	1118mm
N	62 ¹ / ₄ "	1581mm
O	31 ¹ / ₈ "	790mm
ROD	16 ¹ / ₂ "	419mm
ROW	39 ¹ / ₂ "	1003mm
ROH	34 ³ / ₄ "	883mm

Table 3

Fig. 2

Termination Clearances

Termination clearances for buildings with combustible and noncombustible exteriors.

Inside Corner

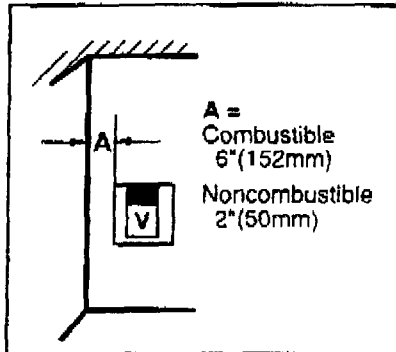

Outside Corner

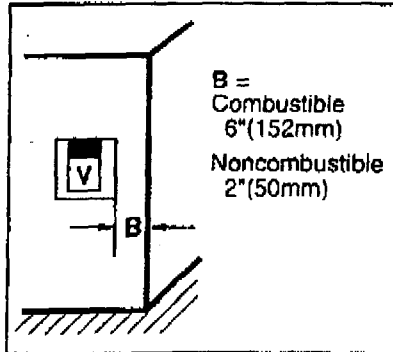

Recessed Location

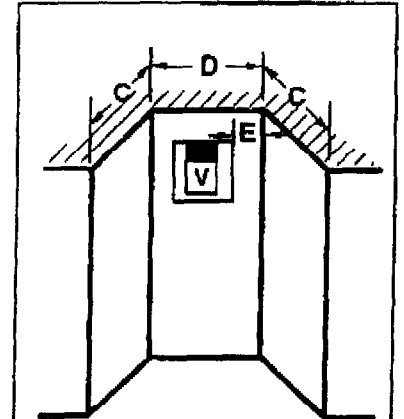

Balcony - with no side wall

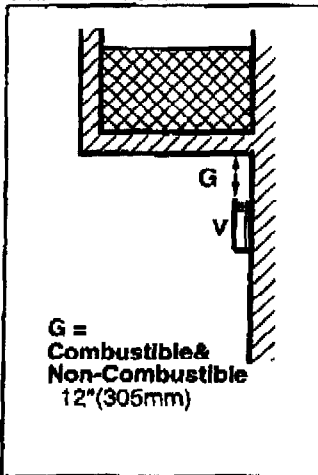

Balcony - with perpendicular side wall

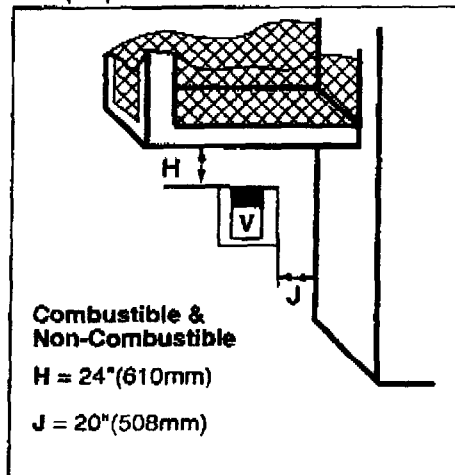

C = Maximum depth of 48"
(1219mm) for recessed
location.
D = Minimum width for back wall
of a recessed location.
Combustible 38" (965mm)
Noncombustible 24" (610mm)
E = Clearance from corner in
recessed location.
Combustible 6" (152mm)
Noncombustible 2" (50mm)

Fig. 11

REAR VENTING APPLICATIONS

Note: It is not necessary to seal the vent pipe joints for any rear vent applications.

Minimum clearances between vent pipe and combustible materials are as follows:

Top - 2" (50 mm)

Sides - 1" (25 mm)

Bottom - 1" (25 mm)

Note: Vent Starter Kit Model 7DVRVT must be used in rear vent applications.

Maximum Vent Length 20" - Fig. 12

..... 20" - With 45 Elbow

Maximum Number of Elbows One 45° Elbow - Fig. 13

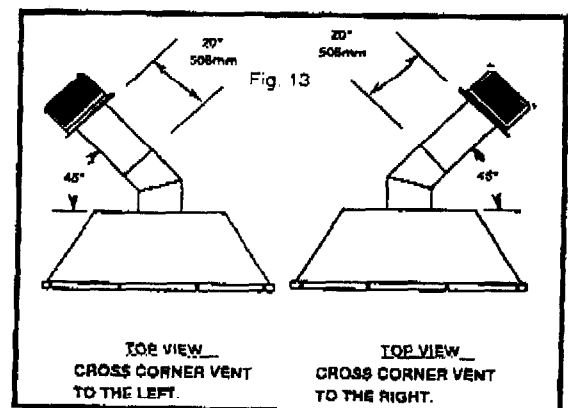
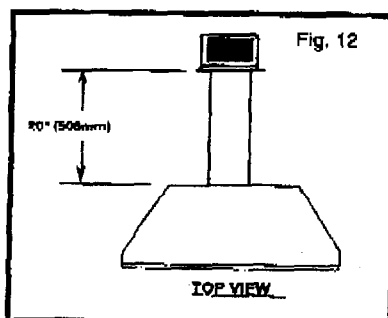

City of Portland, Maine - Building or Use Permit

389 Congress Street, 04101 Tel: (207) 874-8703, Fax: (207) 874-8716

Permit No: 04-0094	Date Applied For: 02/03/2004	CBL: 153 A025007
------------------------------	--	----------------------------

Location of Construction: 33 Kimberly Ct	Owner Name: Nial Construction Inc	Owner Address: 191 State Rd Ste # 2	Phone:
Business Name:	Contractor Name: Pine State Plumbing & Heating	Contractor Address: PO Box 6308 Scarborough	Phone (207) 883-1200
Lessee/Buyer's Name	Phone:	Permit Type: HVAC	

Proposed Use: Condo/ Install a Majestic direct vent gas Fireplace	Proposed Project Description: Condo/ Install a Majestic direct vent gas Fireplace
---	---

Dept: Zoning	Status: Approved	Reviewer: Marge Schmuckal	Approval Date: 02/03/2004
Note:			Ok to Issue: <input checked="" type="checkbox"/>
Dept: Building	Status: Approved	Reviewer: Tammy Munson	Approval Date: 02/04/2004
Note:			Ok to Issue: <input checked="" type="checkbox"/>
Dept: Fire	Status: Approved with Conditions	Reviewer: Lt. MacDougal	Approval Date: 02/04/2004
Note:			Ok to Issue: <input checked="" type="checkbox"/>
1) propane tank shall require a permit			