

NOTES: 1. IN WORK AREA THE 100' MAX. IS APPLICABLE TO THE ENTIRE PROJECT. 2. ALL DIMENSIONS ARE UNLESS OTHERWISE NOTED. 3. SEE THE PROJECT MANUAL FOR THE LATEST REVISIONS TO THE SPECIFICATIONS.

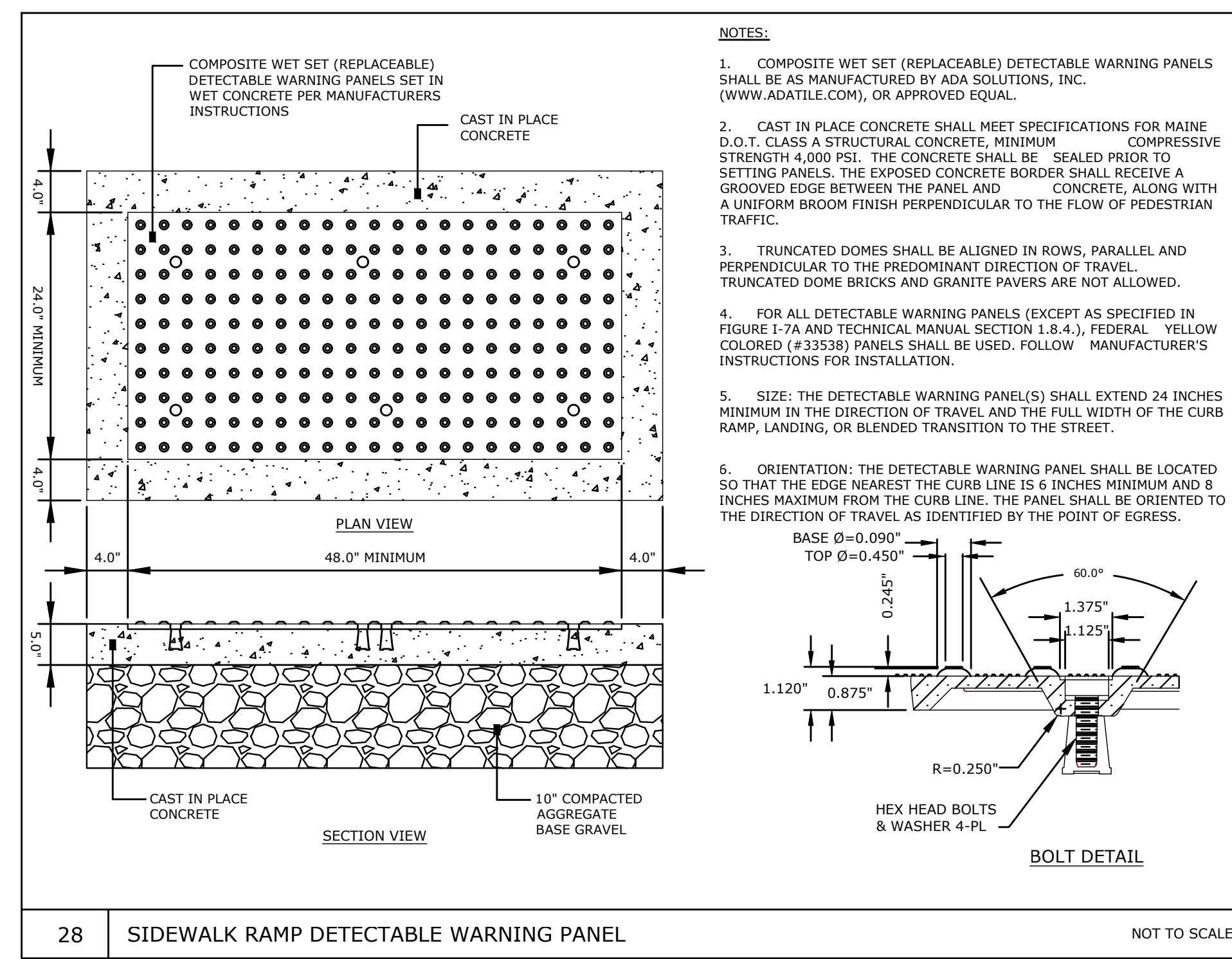
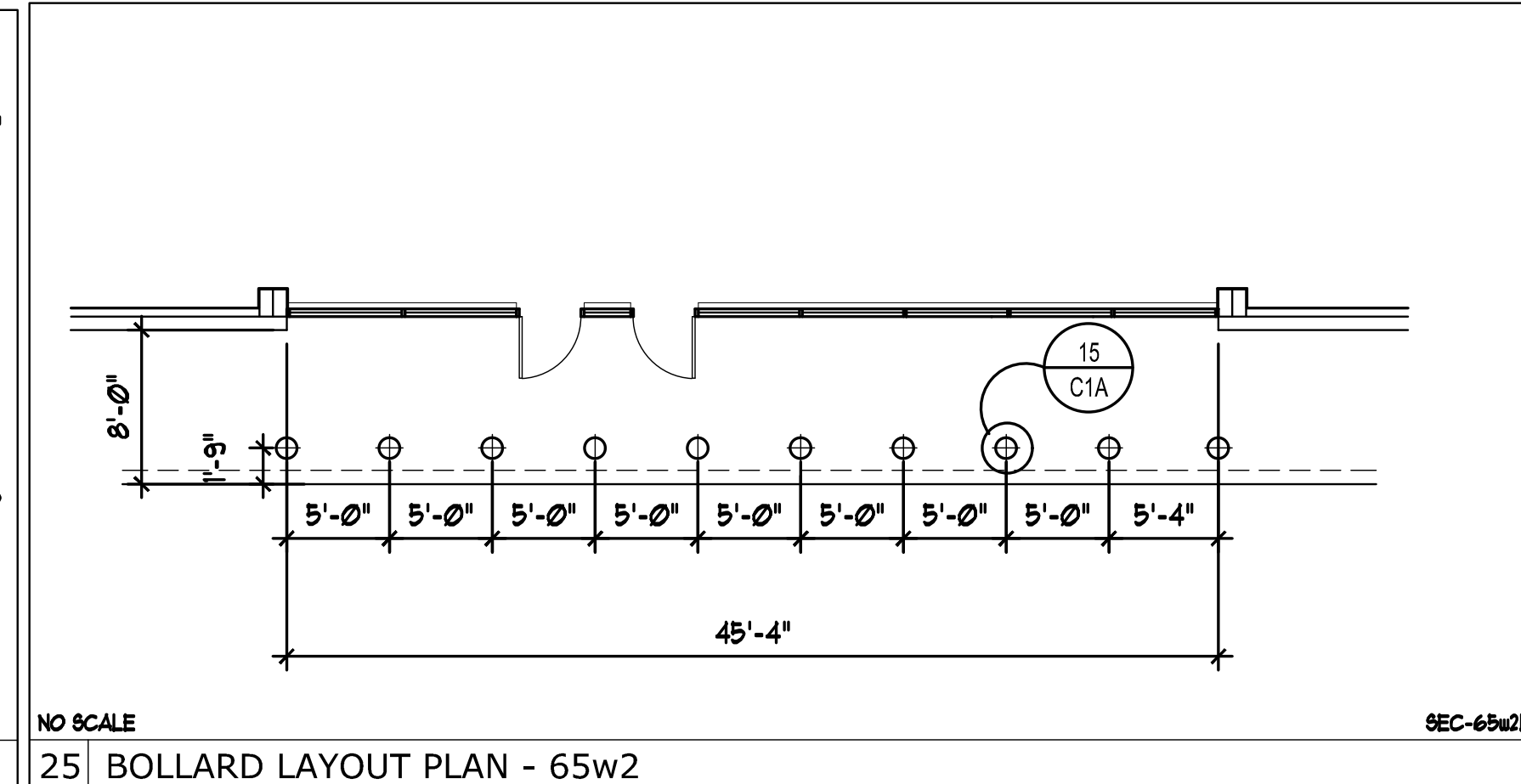
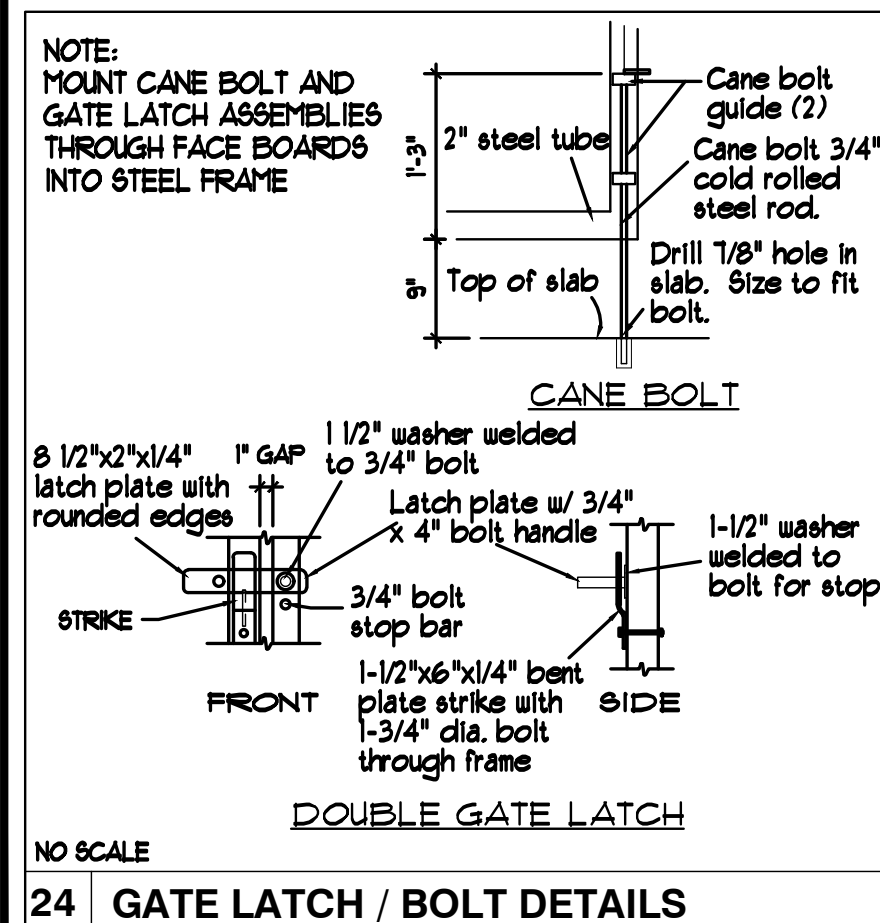
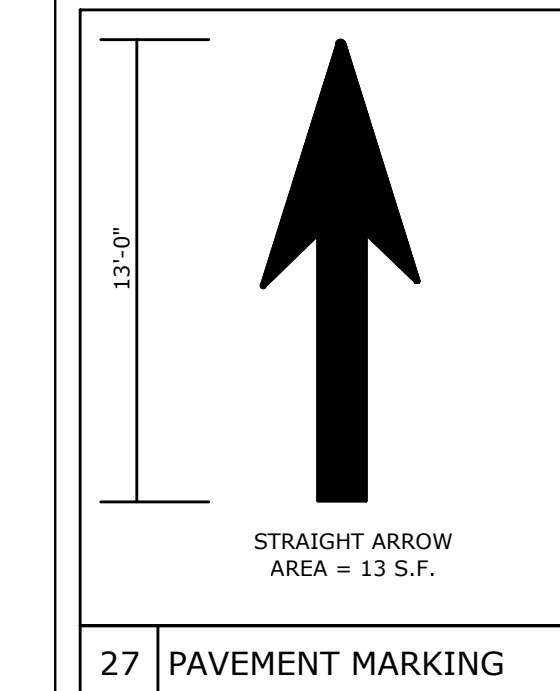
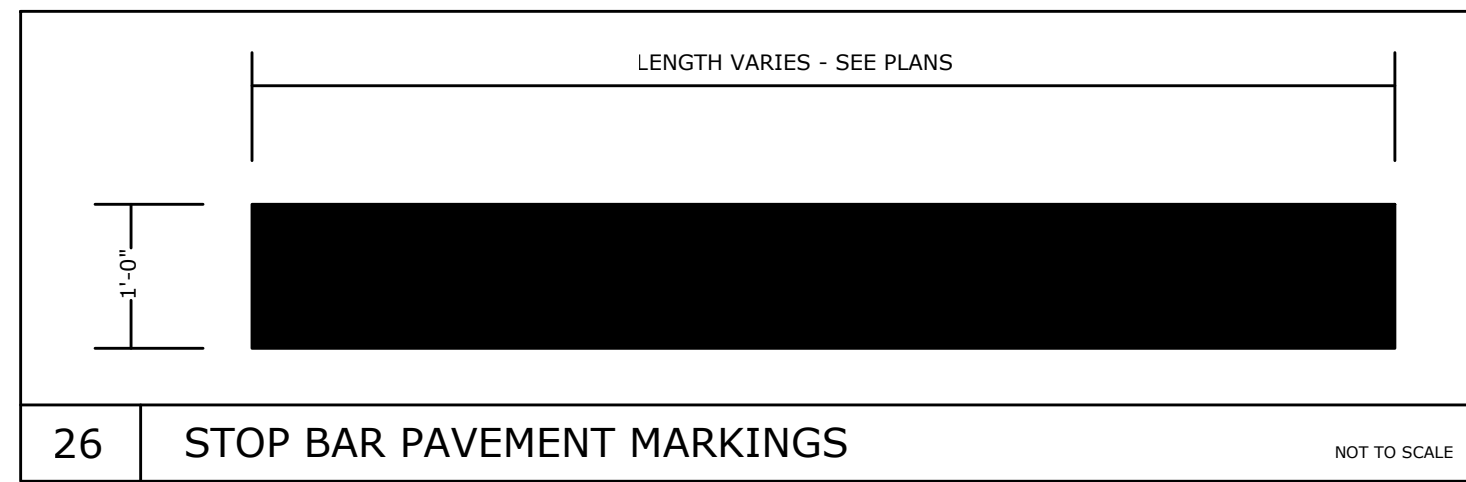
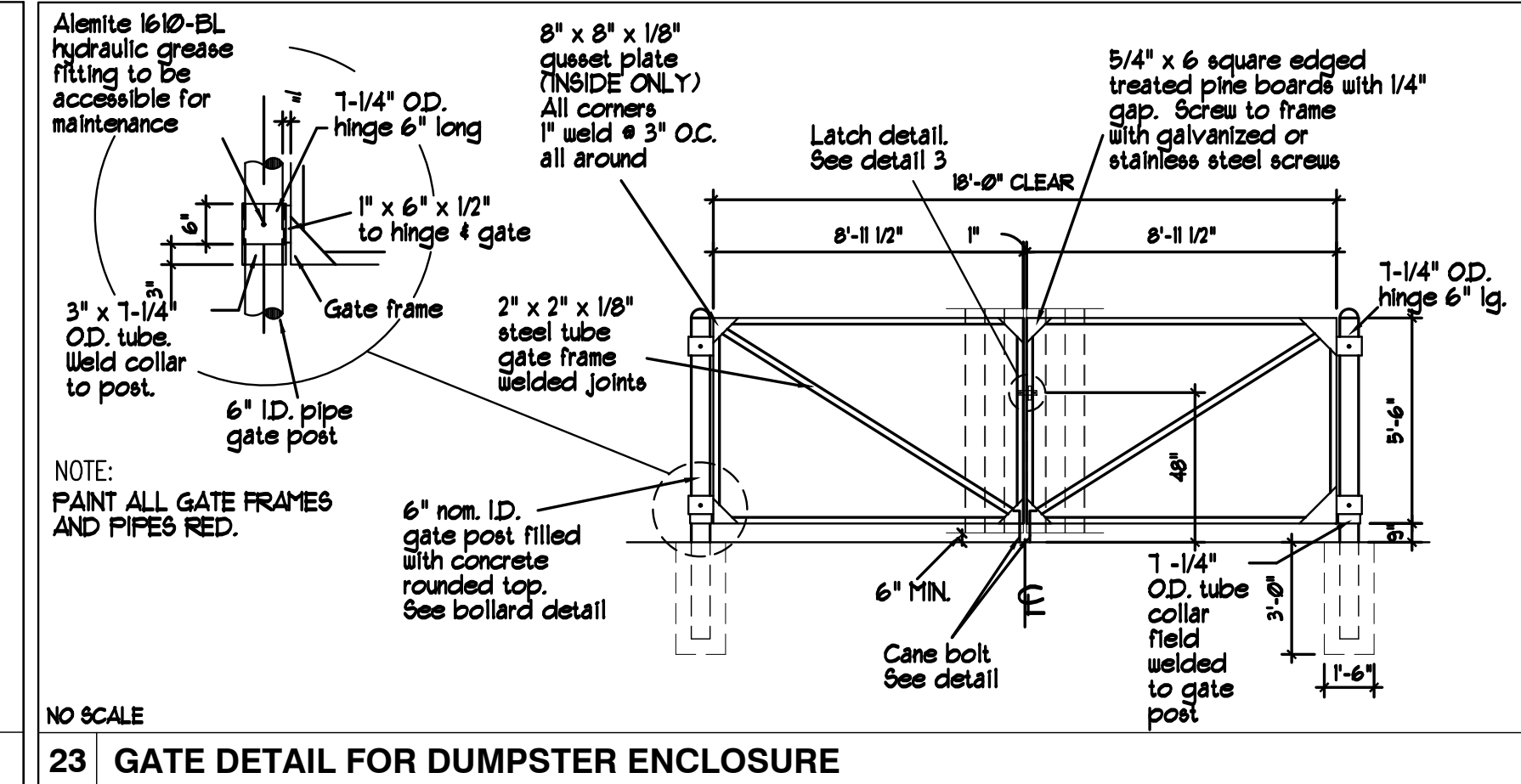
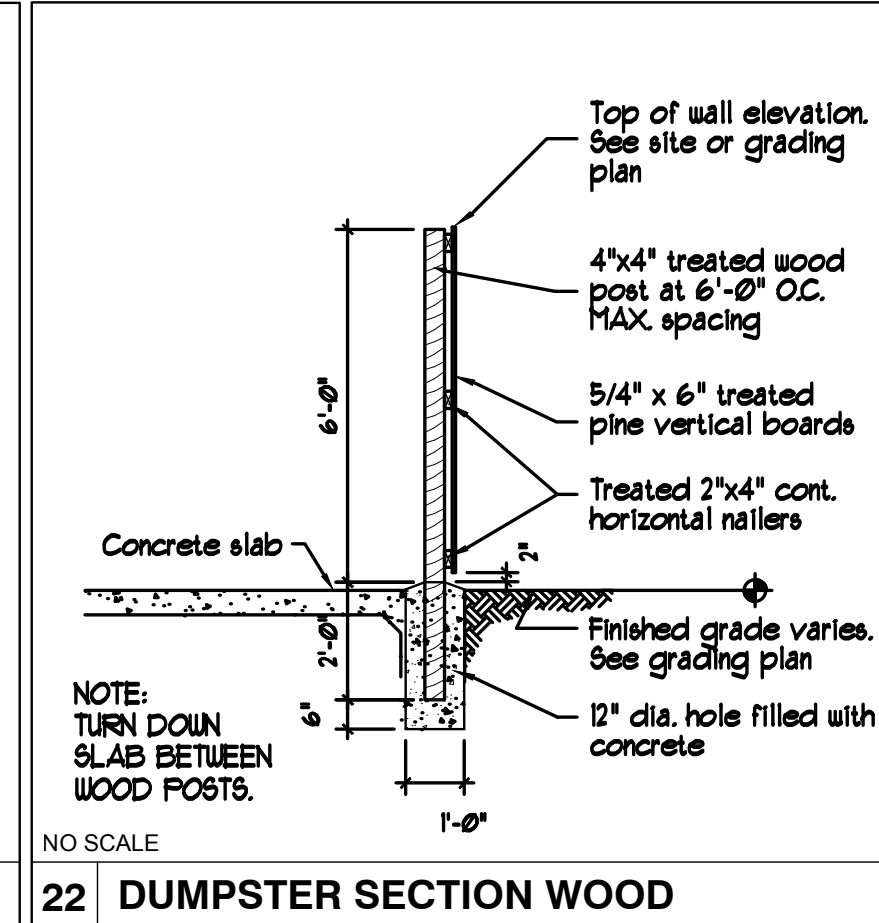
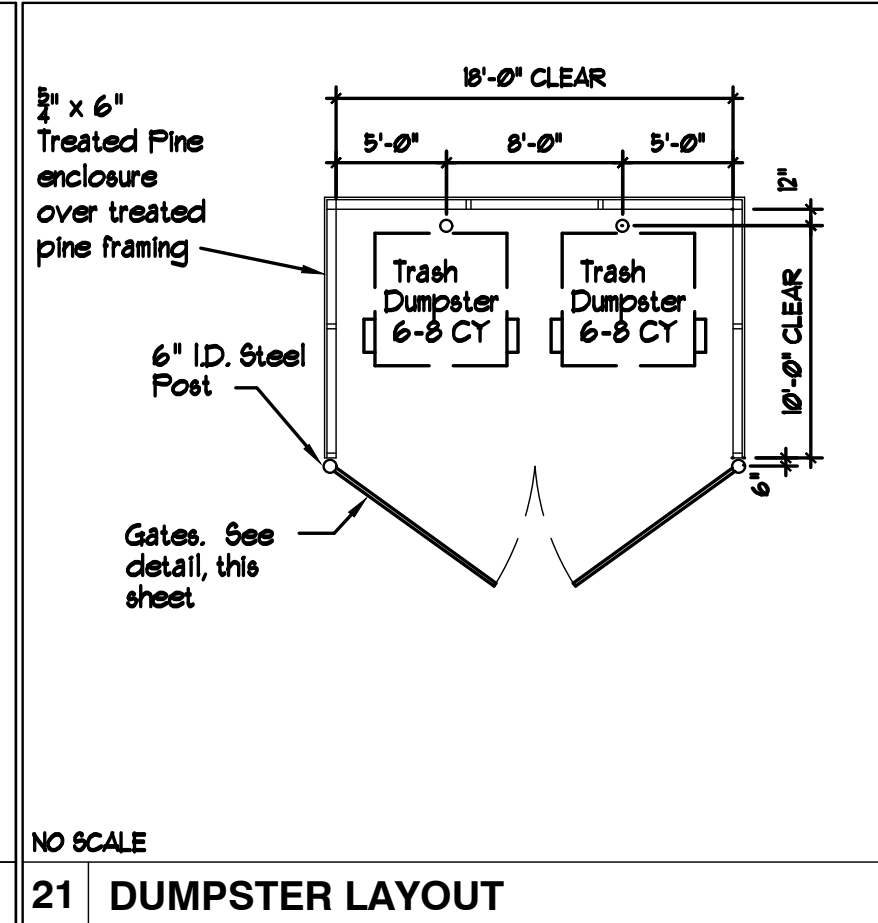
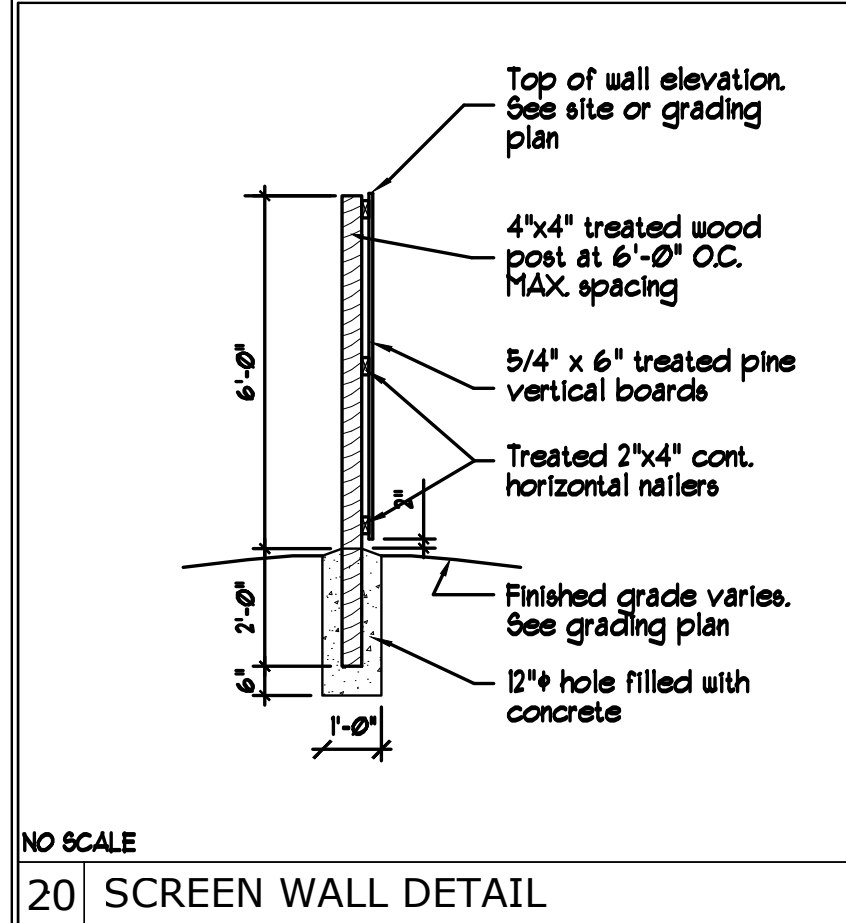
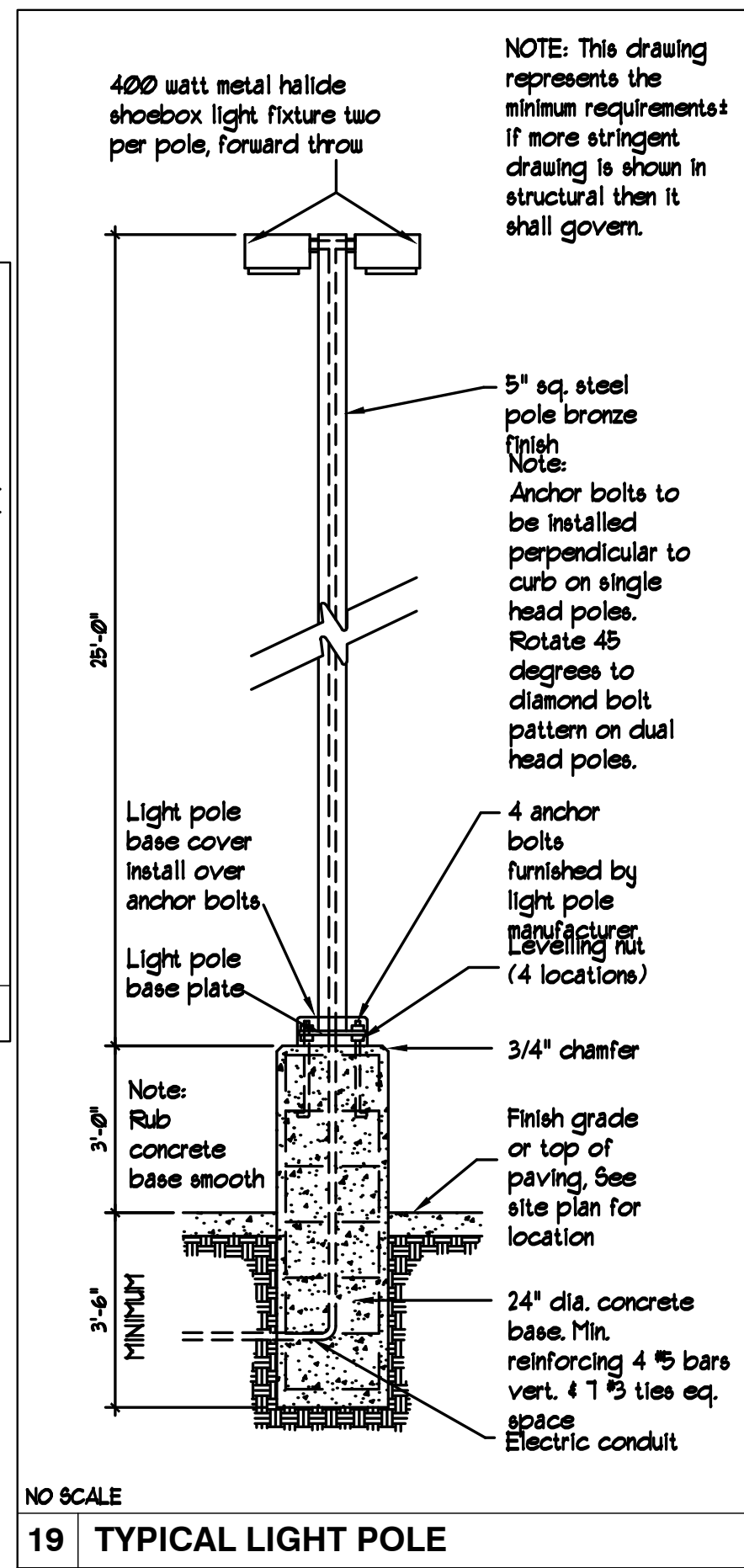
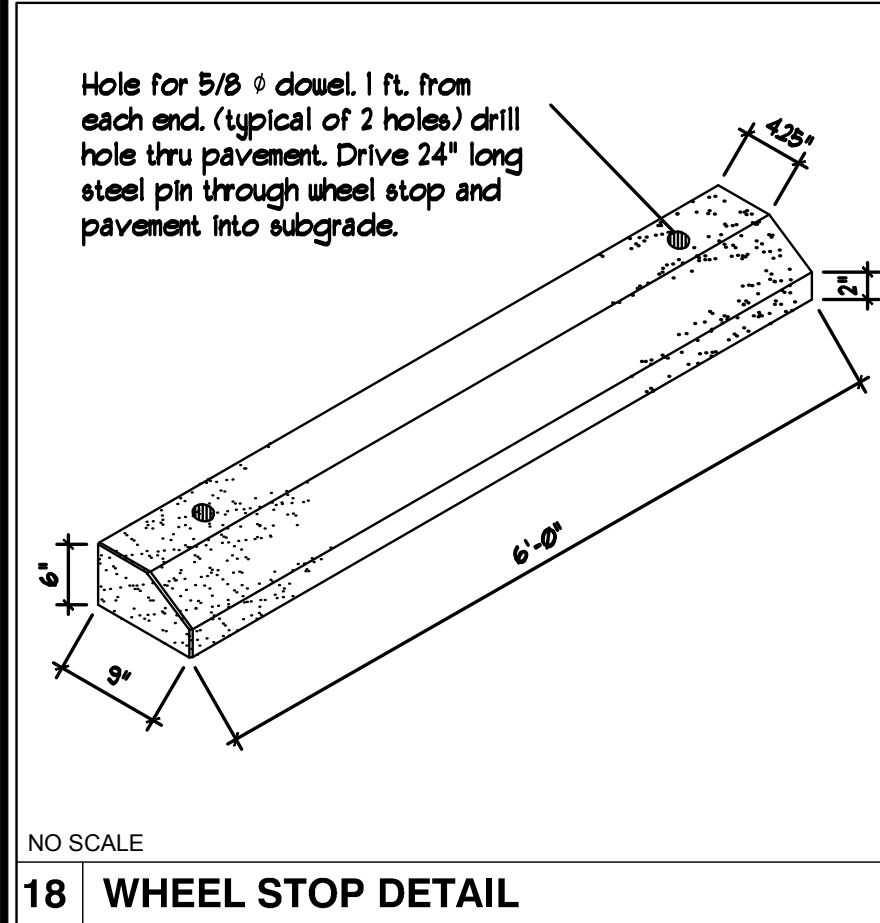
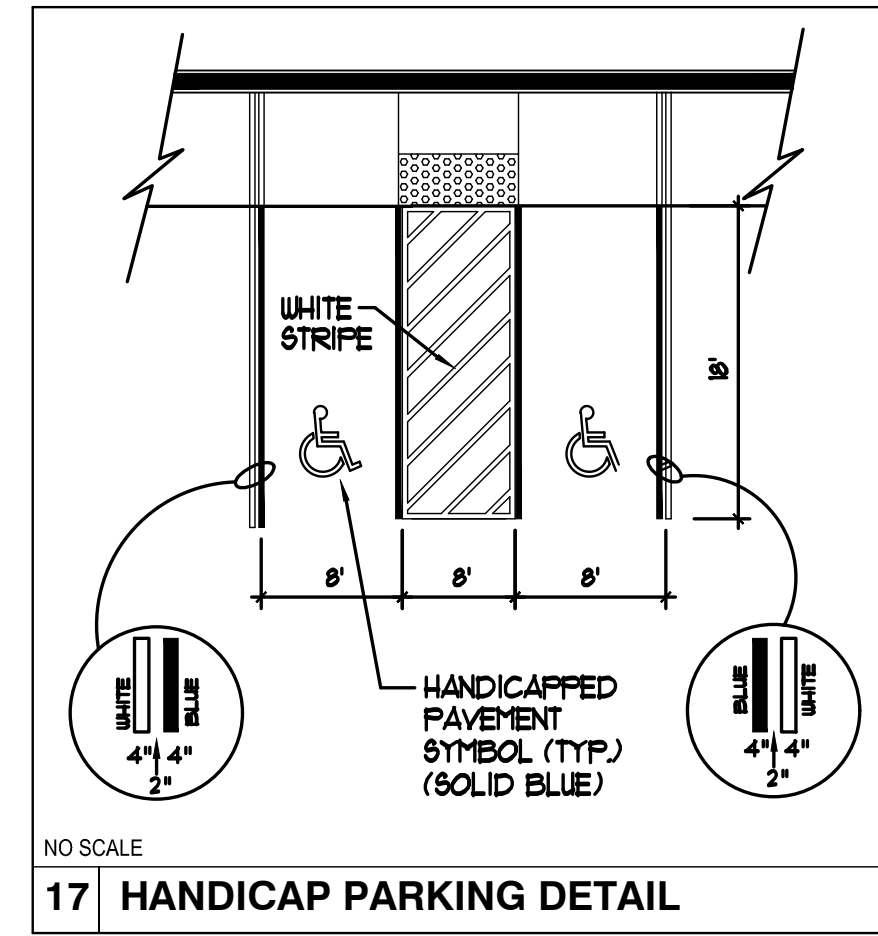
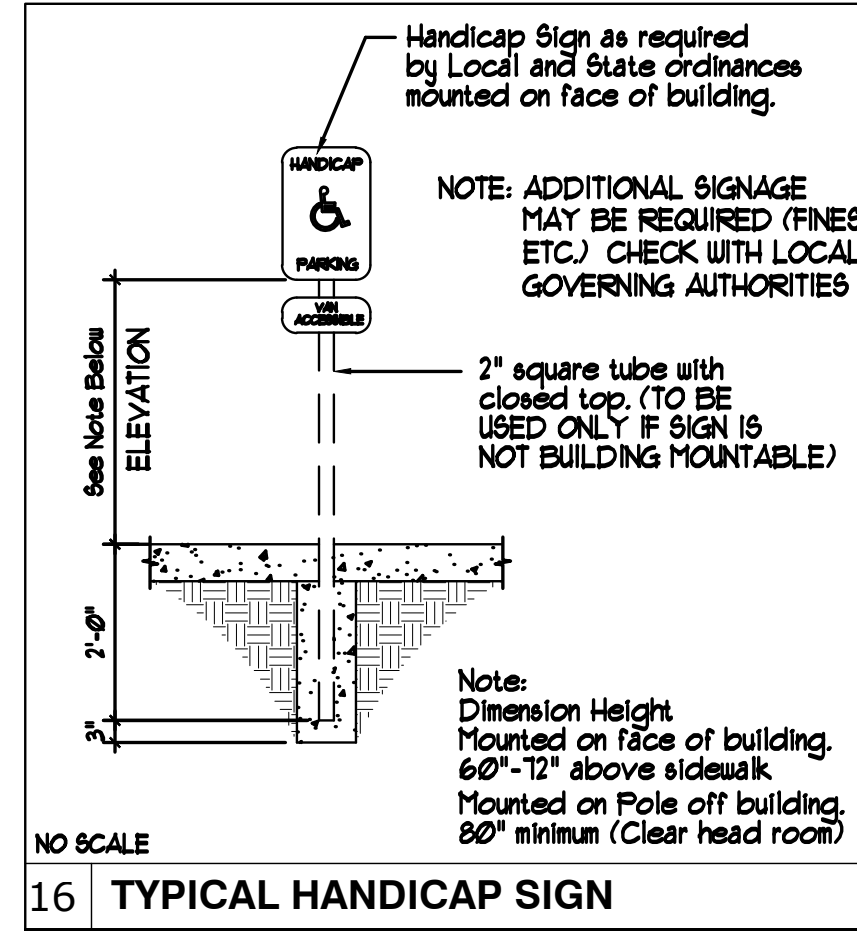
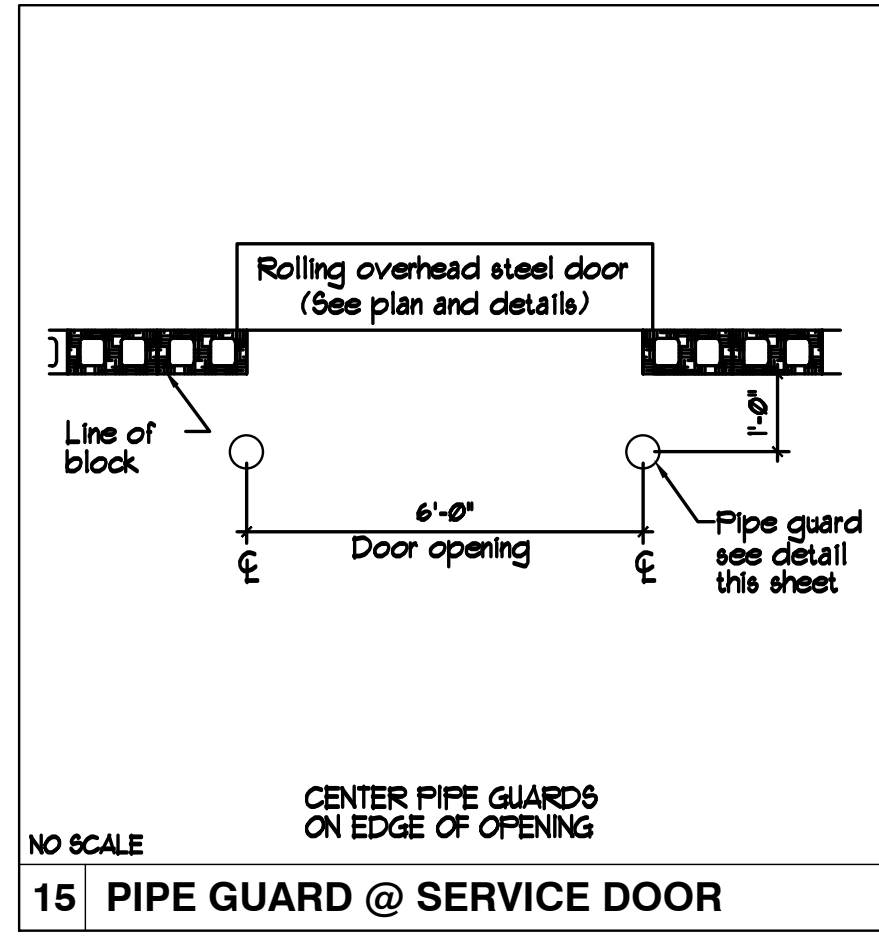
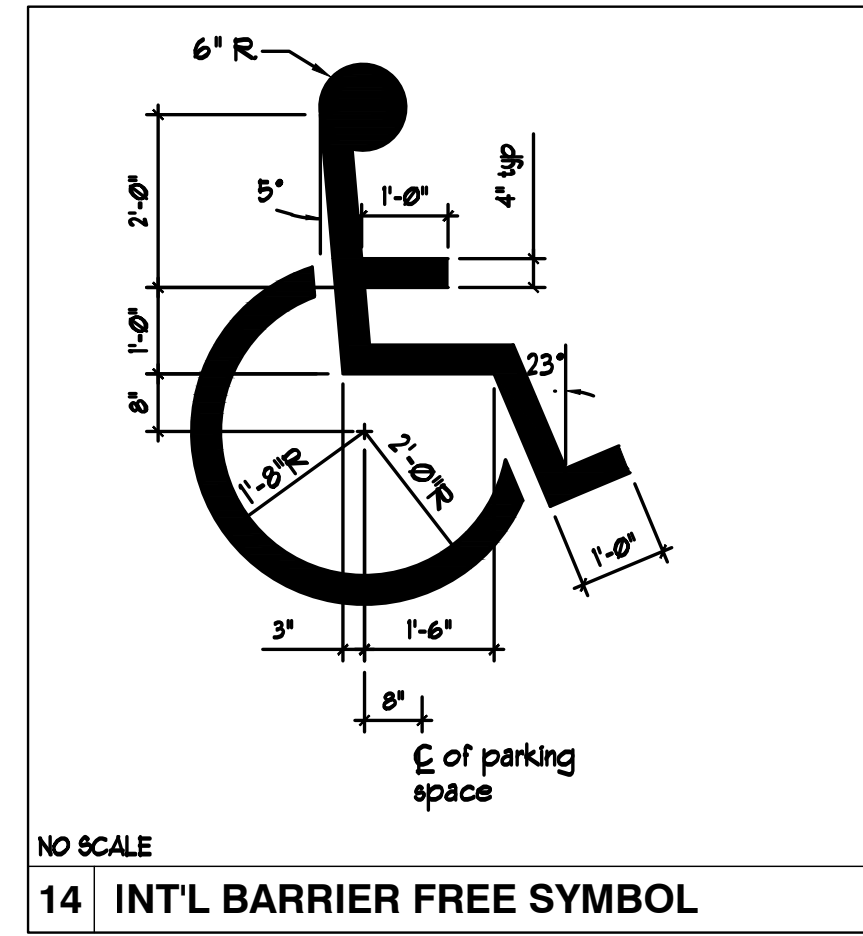
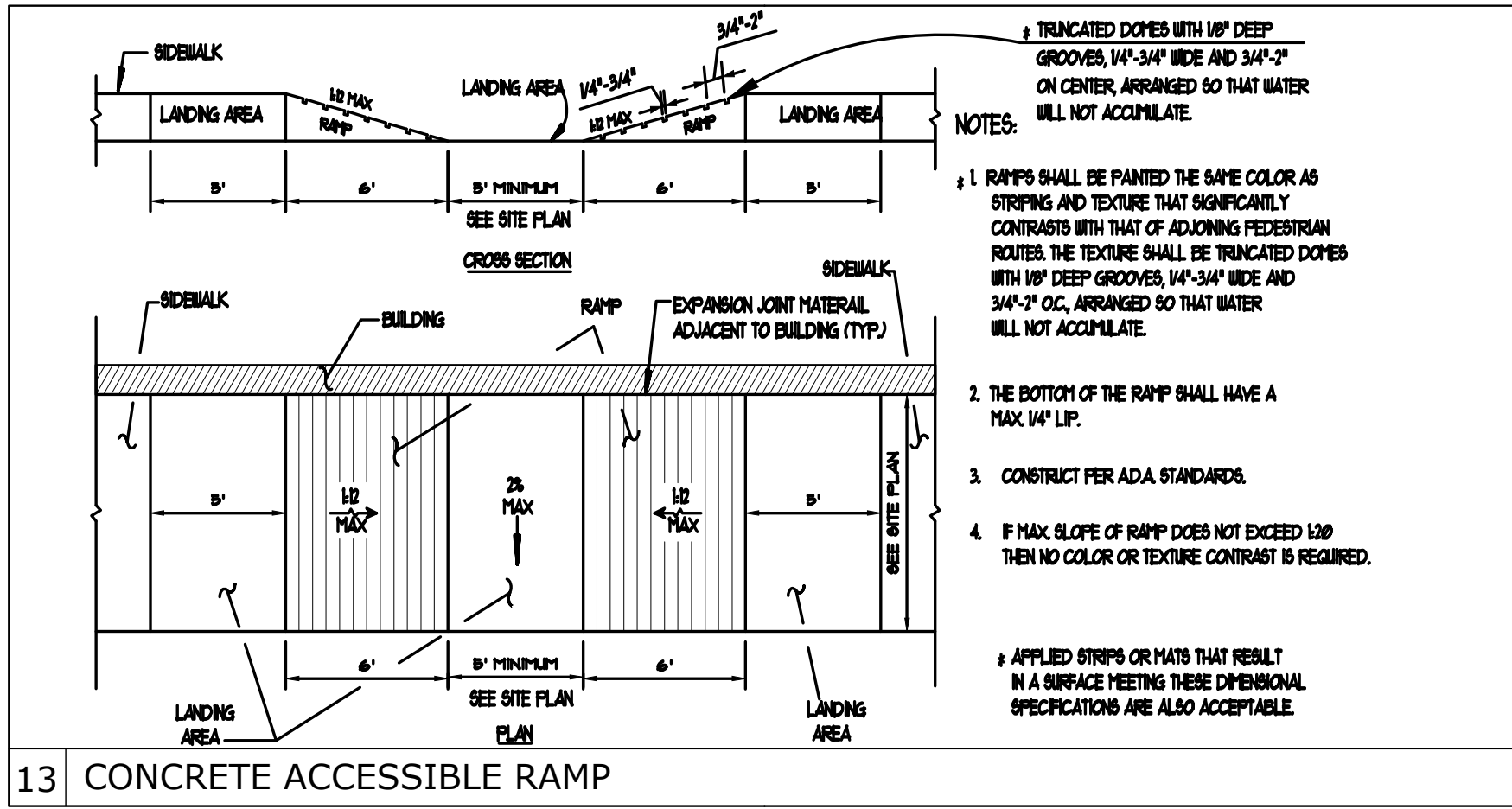

MILONE & MACBROOM
 121 Middle Street
 Suite 201
 Portland, Maine 04101
 (207) 541-9544 Fax (207) 541-9548
 www.miloneandmacbroom.com

DESCRIPTION	DATE	BY

SITE DETAILS
 AUTOZONE STORE NO. 3879
 PORTLAND, MAINE
 1207 FOREST AVE
 PORTLAND, MAINE

SMW	SMW	JQA
DESIGNED	DRAWN	CHECKED
NTS		
DATE: MARCH 16, 2016		
PROJECT NO.: 5464-04		
SHEET NO.: 7 OF 12		

C1.B