

TYPICAL SIDEWALK & CURB SECTION
NOT TO SCALE

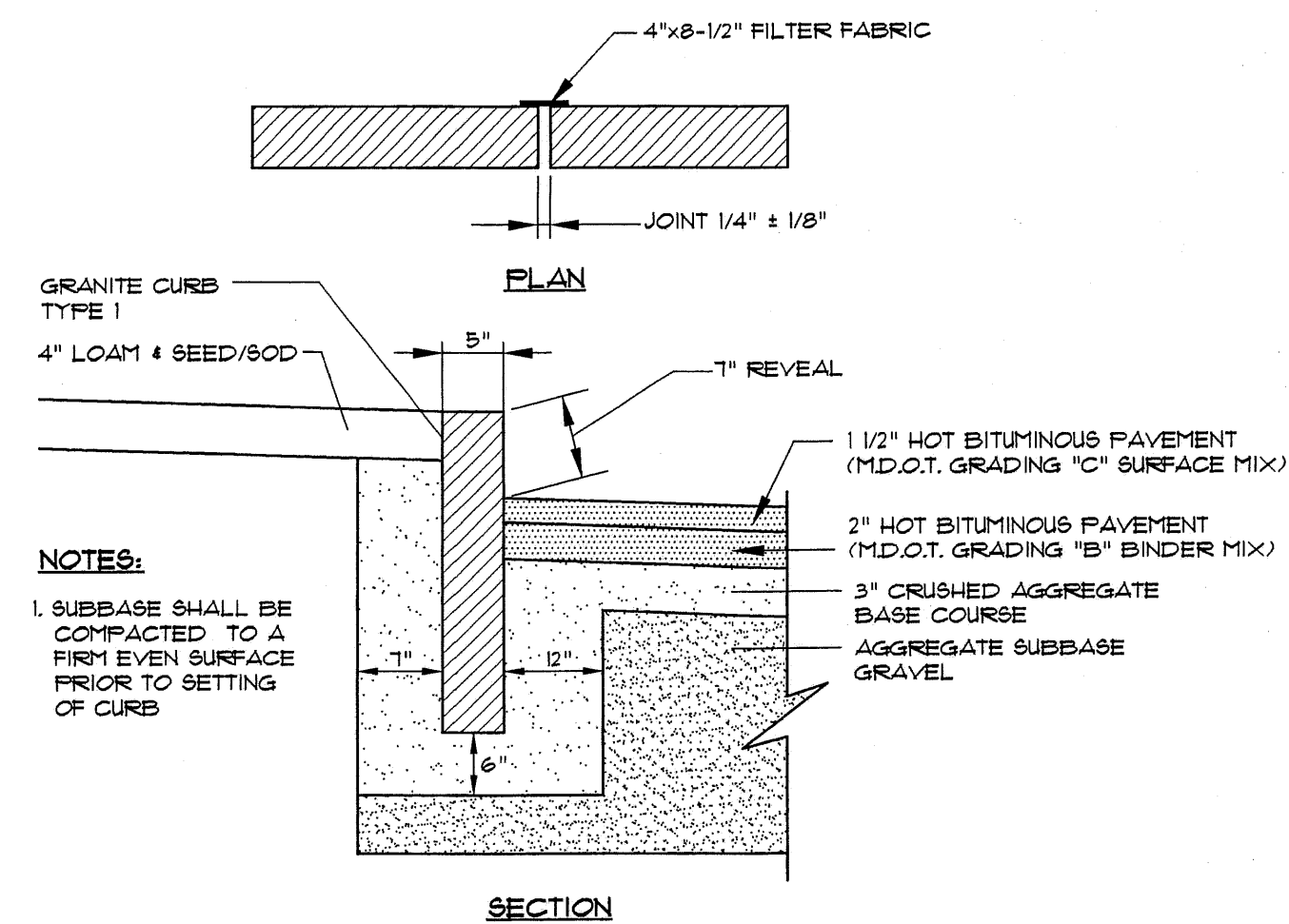

VERTICAL GRANITE CURB
NOT TO SCALE

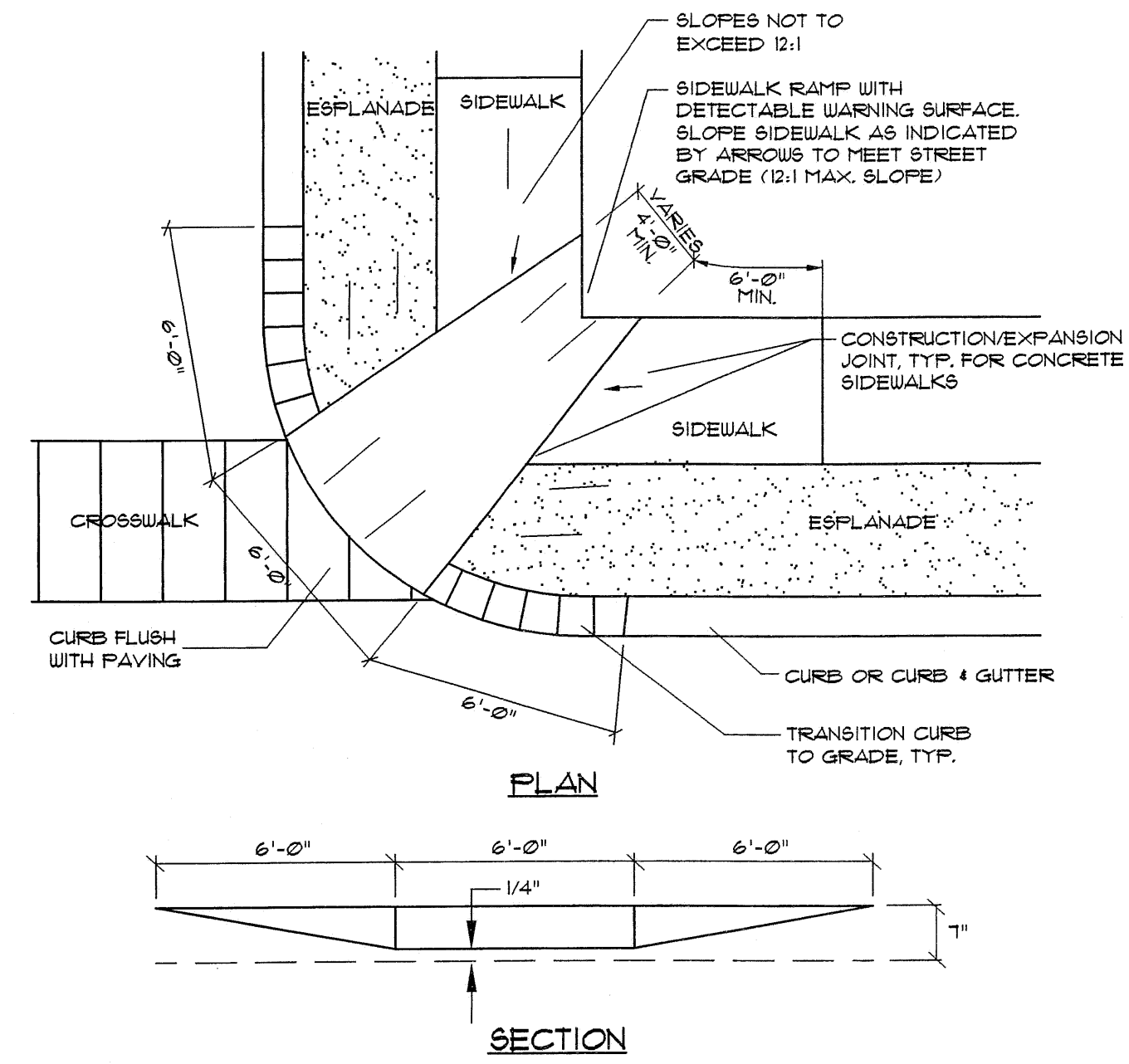

DOUBLE SIDEWALK RAMP WITH ESPALANADE
NOT TO SCALE

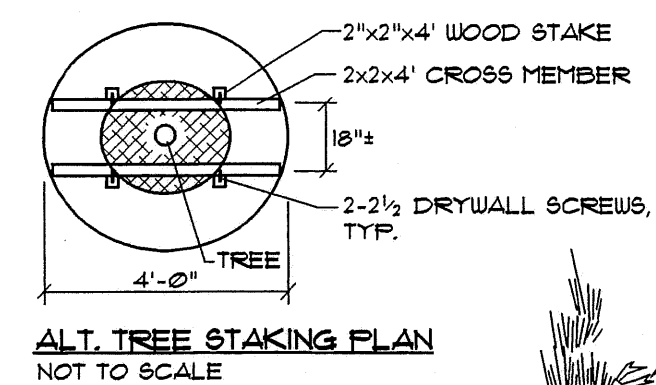

ALT. TREE STAKING PLAN
NOT TO SCALE

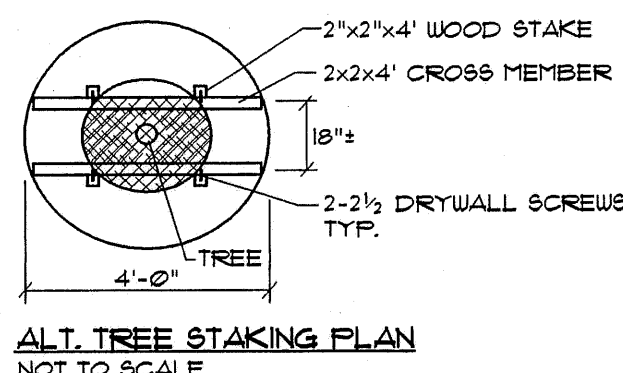

ALT. TREE STAKING PLAN
NOT TO SCALE

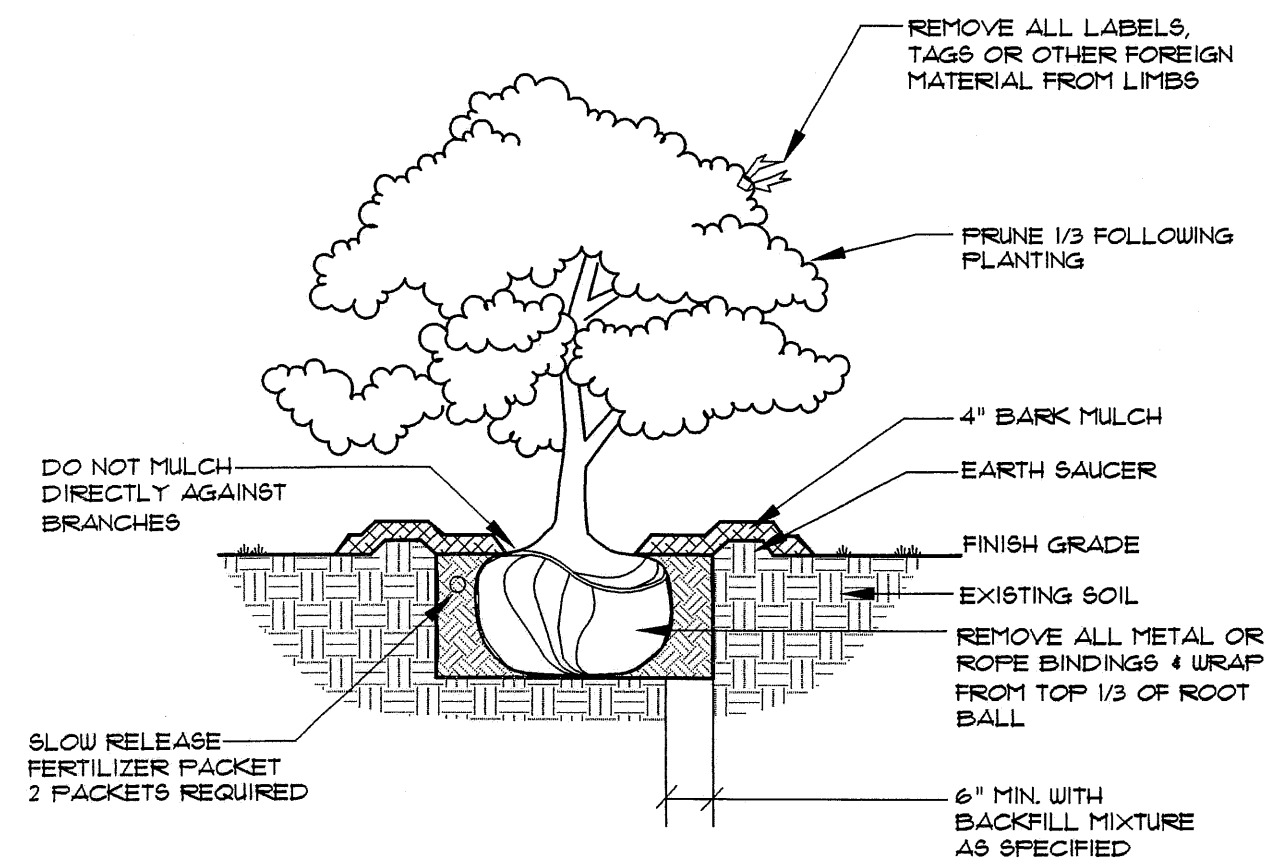

DECIDUOUS & EVERGREEN SHRUB
NOT TO SCALE

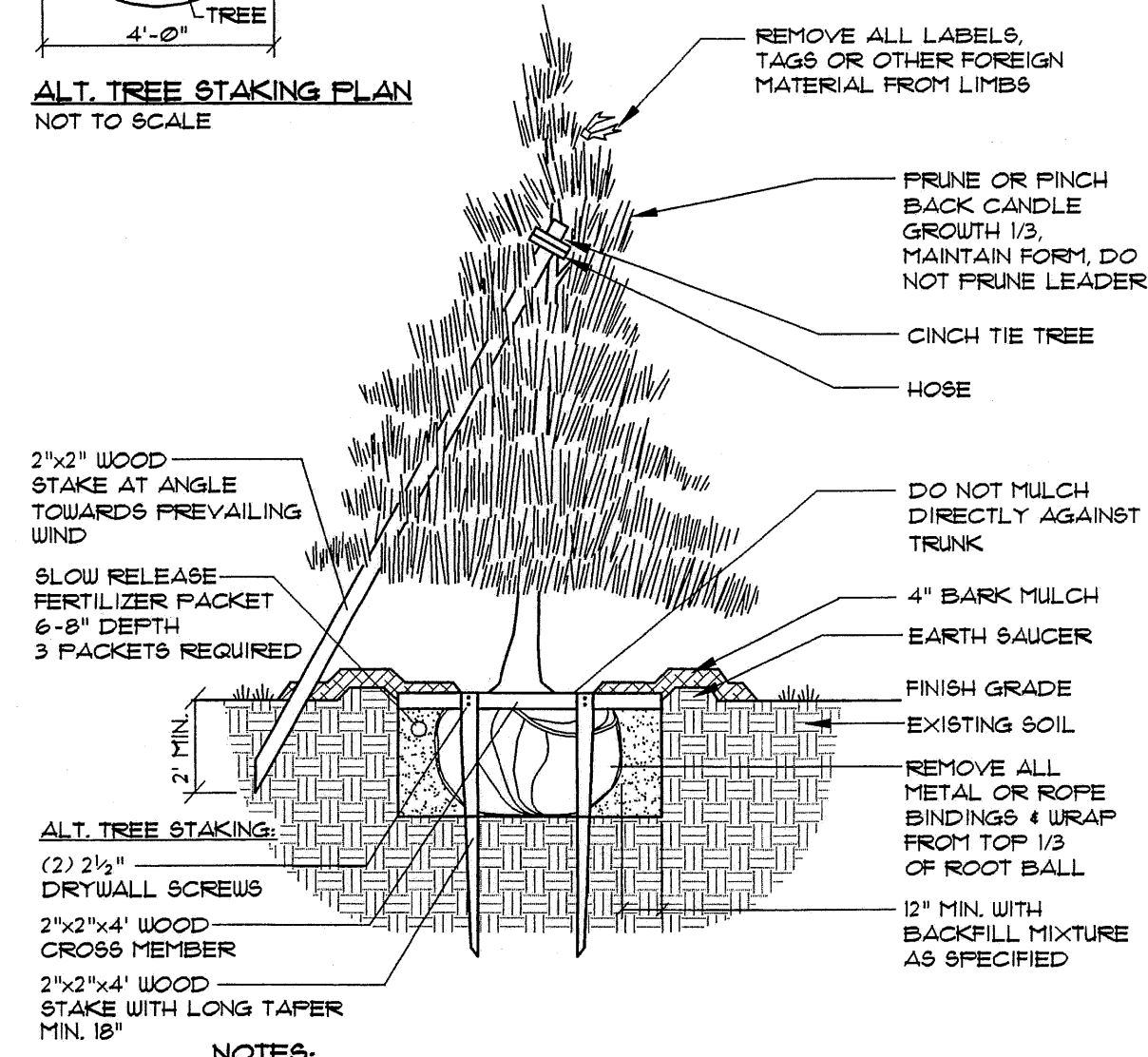

DECIDUOUS TREES UNDER 2\"/>

EVERGREEN TREES 1\"/>

NOT TO SCALE

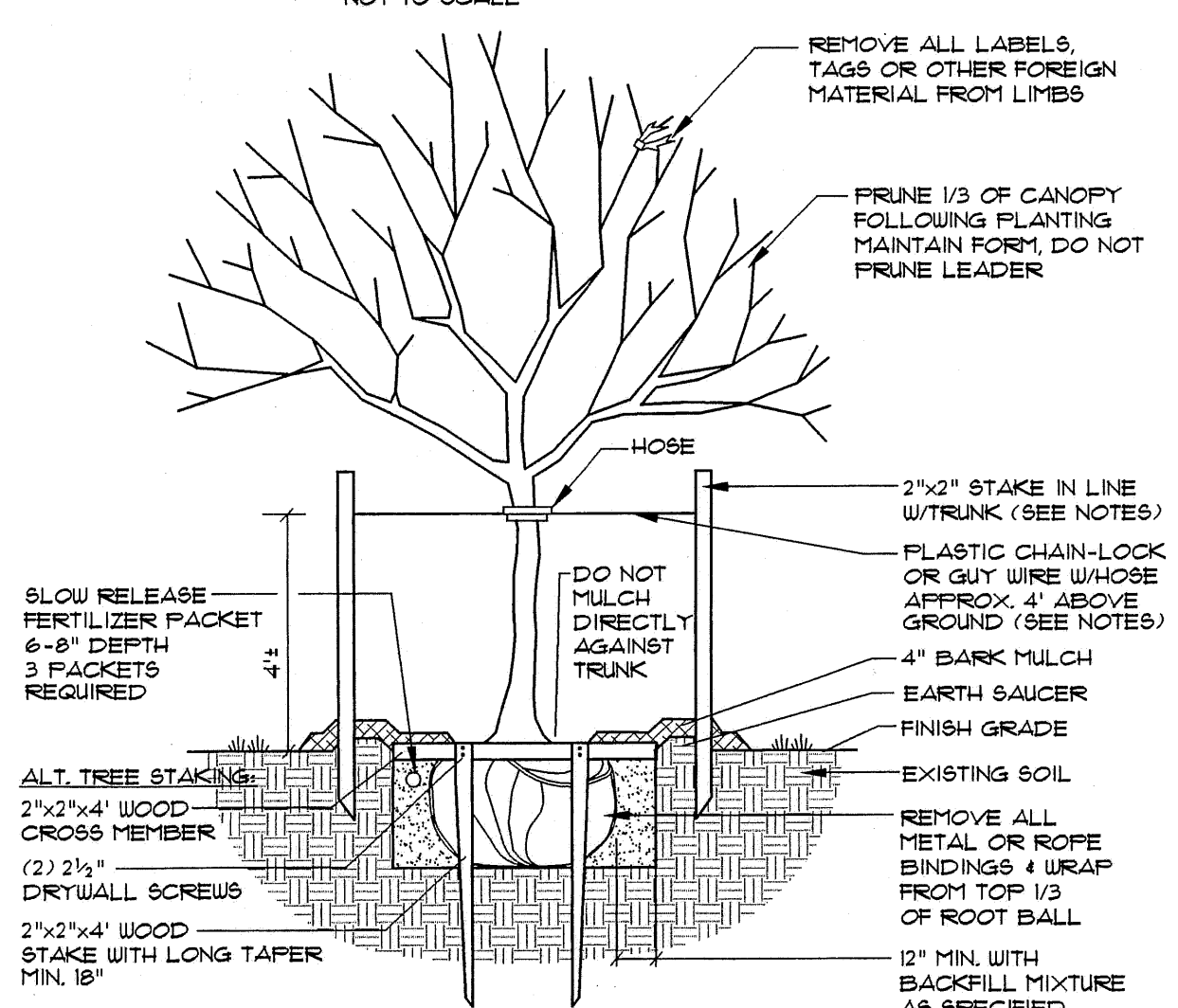

DECIDUOUS TREES 2\"/>

NOT TO SCALE

LANDSCAPE NOTES

1. PLANT QUANTITIES SHOWN ON PLANT LISTS ARE FOR CONVENIENCE TO THE CONTRACTOR ONLY. THE CONTRACTOR IS RESPONSIBLE FOR ALL PLANT MATERIAL INSTALLATION AS SHOWN ON PLANS.
2. SIZE AND GRADING STANDARDS OF PLANT MATERIALS SHALL CONFORM TO THE LATEST EDITION OF "U.S.A. STANDARD FOR NURSERY STOCK," BY THE AMERICAN ASSOCIATION OF NURSERYMEN, INC.
3. ALL PLANT MATERIAL SHALL BE FREE FROM INSECTS AND DISEASE.
4. ALL PLANTINGS SHALL BE DONE IN ACCORDANCE WITH ACCEPTABLE HORTICULTURAL PRACTICES. THIS IS TO INCLUDE PROPER PLANTING MIX, PLANT BED AND TREE PIT PREPARATION, PRUNING, STAKING OR GUYING, WRAPPING, SPRAYING, FERTILIZATION, PLANTING AND ADEQUATE MAINTENANCE UNTIL ACCEPTANCE BY THE OWNER.
5. PLANT MATERIAL SHALL BE GUARANTEED FOR A PERIOD OF ONE YEAR BY THE CONTRACTOR AND A PERIOD OF TWO YEARS THEREAFTER BY THE OWNER FROM DATE OF INSTALLATION. DURING THE ONE YEAR GUARANTEE PERIOD, DEAD PLANT MATERIAL SHALL BE REPLACED AT NO COST TO THE OWNER. AT THE END OF THE ONE YEAR PERIOD, THE CONTRACTOR SHALL OBTAIN FINAL ACCEPTANCE FROM THE OWNER.
6. ALL GRASS, OTHER VEGETATION AND DEBRIS SHALL BE REMOVED FROM ALL PLANTING AREAS PRIOR TO PLANTING.
7. EXISTING TREES TO BE PRESERVED WILL BE PROTECTED DURING CONSTRUCTION AND SHALL BE THE RESPONSIBILITY OF THE GENERAL CONTRACTOR.
8. THE LANDSCAPE CONTRACTOR IS ADVISED OF THE PRESENCE OF THE UNDERGROUND UTILITIES AND SHALL VERIFY THE EXISTENCE AND LOCATION OF SAME BEFORE COMMENCING AND DIGGING OPERATIONS. THE LANDSCAPE CONTRACTOR SHALL REPLACE OR REPAIR UTILITIES, PAVING, WALKS, CURBS, ETC. DAMAGED IN PERFORMANCE OF THIS JOB AT NO ADDITIONAL COST TO THE OWNER.
9. ALL SHRUB BEDS SHALL BE MULCHED WITH 3\"/>

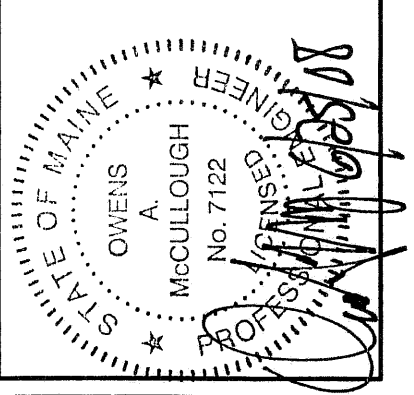

PROJECT NO.	08224
FIELD BOOK	
DESIGN	SAG
CHKD	OAM
DRAWN	JKS
REV.	A
BY	SAG
DATE	6/4/08
CITY	WESTBROOK, ME
STATUS	CITY SITE PLAN REVIEW

Sebago Technics
Engineering Experts You Can Build On
100 West Street
Westbrook, ME 04095-1339
Tel (207) 856-0277

GRONDI PROPERTIES LLC.
11 BARTLAT ROAD
CORHAM, MAINE 04038

DETAILS OF READ STREET SELF STORAGE
217 READ STREET
PORTLAND, MAINE