

**LAYOUT PLAN at EXIST'G STORAGE PLATFORM ABOVE SHOPS**  
1/16" = 1'-0"

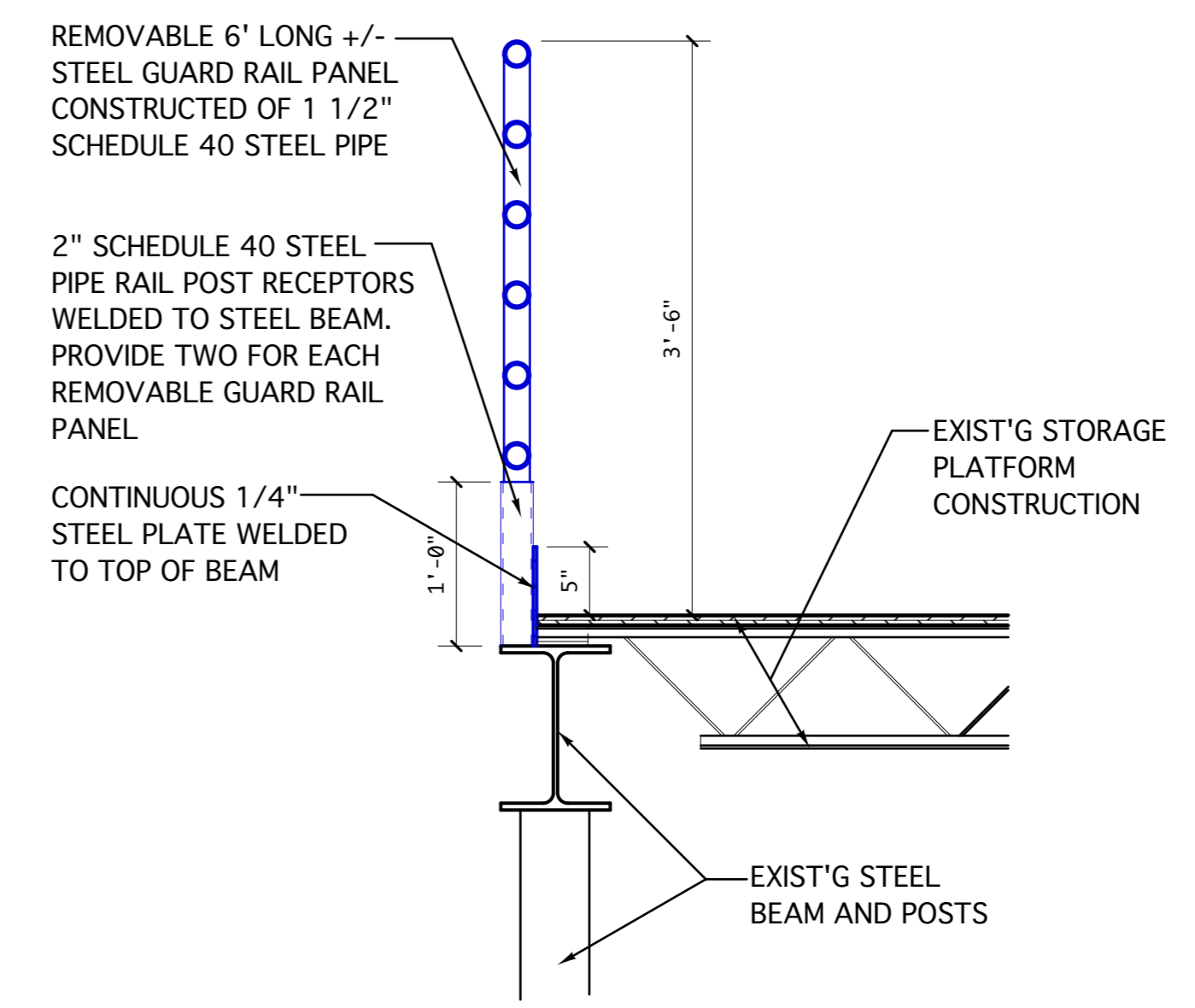

**1 STORAGE PLATFORM REMOVABLE GUARD RAIL SECTION DETAIL**  
1" = 1'-0"

**FIRST FLOOR LAYOUT PLAN**  
1/16" = 1'-0"

City of Portland  
Public Facilities  
Operation  
Center

212 Canco Road  
Portland, Maine

REVISIONS

PERMIT DRAWINGS  
August 18, 2014

Layout Plan

Scale: As Noted