

LIFE SAFETY & INCIDENT MANAGEMENT

Intelligent Multisensor Smoke and CO Detector

SIGA-PCD



Overview

The Signature Series SIGA-PCD detector brings advanced multi-sensor technology to a practical design that increases efficiency, saves installation time, cuts costs, and extends life safety and property protection capabilities. Continuous self-diagnostics ensures reliability over the long-haul, while environmental compensation helps reduce maintenance costs.

The SIGA-PCD provides a combination of optical detection for the early detection of smoke, with the added element of carbon monoxide sensing. The result is a detector that pulls double duty: continually monitoring the environment for signs of fire — as well as its invisible yet deadly companion: carbon monoxide.

Like all Signature Series detectors, the SIGA-PCD gathers analog information from its sensing elements and converts this data into digital signals. To make an alarm decision, the detector's on-board microprocessor measures and analyzes smoke sensor readings and compares this information to historical data. Digital filters remove signal patterns that are not typical of fires, thus virtually eliminating unwanted alarms. The detector also analyzes the smoke sensor independently from the CO sensor to determine whether to initiate a fire alarm, a life safety CO alarm, or both.

Standard Features

Note: Some features described here may not be supported by all control systems. Check your control panel's Installation and Operation Guide for details.

- Next Generation Detection Technology
- Integrates optical smoke with carbon monoxide detection
- Wide 0.53 to 3.94 %/ft. (1.7 to 12.35 %/m) smoke obscuration
- Sensor Markings Provide Easy Testing Identification
- Uses existing wiring
- Automatic device mapping
- Ground fault detection by module
- Up To 250 Total Signature Addresses Per Loop
- Two levels of environmental compensation
- Two levels of dirty detector warning
- Twenty pre-alarm settings
- Five sensitivity settings
- Non-volatile memory
- Electronic addressing
- Environmental compensation
- Automatic day/night sensitivity adjustment
- Bicolor (green/red) status LED
- Standard, relay, fault isolator, and audible mounting bases

Application

Smoke detection

The SIGA-PCD detects extremely small particles of combustion and triggers an alarm at the first sign of smoke. Thanks to its high-performance forward-scattering reflective response technology, the photoelectric smoke sensor responds quickly and reliably to a wide range of fire types, especially slow burning fires fuelled by combustibles typically found in modern multi-use buildings.

CO Detection

Monitored CO detection, such as that provided by the SIGA-PCD, is becoming mandated with increasing frequency in all types of commercial applications, but particularly in occupancies such as hotels, rooming houses, dormitories, day care facilities, schools, hospitals, assisted living facilities, and nursing homes. Known as the “Silent Killer,” CO is odorless, tasteless, and colorless. It claims nearly 500 lives, and results in more than 15,000 hospital visits annually.

Compatibility

The SIGA-PCD detector is compatible only with the Signature Loop Controller.

Installation

Signature Series detectors mount to North American 1-gang boxes, 3-1/2 inch or 4 inch octagon boxes, and to 4 inch square electrical boxes 1-1/2 inches (38 mm) deep. They mount to European BESA and 1-gang boxes with 60.3 mm fixing centers. See mounting base installation and wiring for more information.

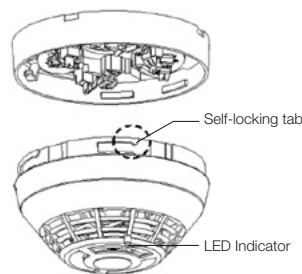

Testing & Maintenance

Scheduled maintenance (regular or selected) for proper detector operation should be planned to meet the requirements of the Authority Having Jurisdiction (AHJ). Refer to current NFPA 72, NFPA 720, and ULC CAN/ULC 536 standards.

Smoke Sensor Sensitivity

The SIGA-PCD determines when its optical sensor is dirty or defective and can transmit sensitivity data to the loop controller. A sensitivity report can also be printed to satisfy NFPA sensitivity measurements which must be conducted at the end of the first year and every two years thereafter. The availability of maintenance features depends on the fire alarm system used.

CO Sensor Life

The CO sensor has a 10-year life from the date of manufacture or when the control panel indicates a sensor end-of-life condition, whichever comes first. When the sensor reaches its end of life, the detector signals a “COMMON TRBL ACT” condition on the control panel. Pressing the **Details** button on the control panel displays “END OF LIFE ACT” providing verification that it is an end-of-life trouble of the CO sensor. This trouble remains active until the detector is replaced, even if the panel is reset.

Sensing and reporting technology

The microprocessor in each detector provides additional benefits - Self-diagnostics and History Log, Automatic Device Mapping, and Fast, Stable Communication.

Self-diagnostics and History Log - Each Signature Series detector constantly runs self-checks to provide important maintenance information. The results of the self-check are automatically updated and permanently stored in the detector’s non-volatile memory.

Automatic Device Mapping - The loop controller learns where each device’s serial number address is installed relative to other devices on the circuit. The mapping feature provides supervision of each device’s installed location to prevent a detector from being reinstalled (after cleaning etc.) in a different location from where it was originally.

Fast Stable Communication - On-board intelligence means less information needs to be sent between the detector and the loop controller. Other than regular supervisory polling response, the detector only needs to communicate with the loop controller when it has something new to report.

Accessories

Detector mounting bases have wiring terminals that are accessible from the “room-side” after mounting the base to the electrical box. The bases mount to North American 1-gang boxes and to 3½ inch or 4 inch octagon boxes, 1½ inches (38 mm) deep. They also mount to European BESA and 1-gang boxes with 60.3 mm fixing centers. The SIGA-SB4, SIGA-RB4, and SIGA-IB4 mount to North American 4 inch sq. electrical boxes in addition to the above boxes. They include the SIGA-TS4 Trim Skirt, which is used to cover the “mounting ears” on the base. Sounder bases mount to a 4 inch square boxes only.



Remote LED SIGA-LED - The remote LED connects to the SIGA-SB or SIGA-SB4 Standard Base only. It features a North American size 1-gang plastic faceplate with a white finish and red alarm LED.

SIGA-TS4 Trim Skirt - Supplied with 4 inch bases, it can also be ordered separately to use with the other bases to help hide surface imperfections not covered by the smaller bases.

Sounder Bases - Signature Series sounder bases are designed for use where localized or group alarm signaling is required.

- **SIGA-AB4GT** bases provide sounder capability to the SIGA-PCD when used with a SIGA-TCDR Temporal Pattern Generator to separate CO (TC4) and Fire (TC3) tone patterns.
- **SIGA-AB4G-LF** bases provide 520 Hz low frequency sounder capability to the SIGA-PCD when used with a SIGA-TCDR Temporal Pattern Generator to separate CO (TC4) and Fire (TC3) tone patterns. The SIGA-AB4G-LF is suitable for applications requiring low frequency audible tones.

Typical Wiring

The detector mounting bases accept #18 AWG (0.75mm²), #16 (1.0mm²), #14 AWG (1.5mm²), and #12 AWG (2.5mm²) wire sizes. Sizes #16 AWG (1.0mm²) and #18 AWG (0.75mm²) are preferred for ease of installation.

Standard Detector Base, SIGA-SB, SIGA-SB4

This is the basic mounting base for EDWARDS Signature Series detectors. The SIGA-LED Remote LED is supported by this Base.

Term	Description
1	Not Used
2	DATA IN/OUT (+)
3	Not Used
4	DATA IN (-)
4	Remote LED (+)
5	Remote LED (+)
6	Not Used
7	DATA OUT (-)

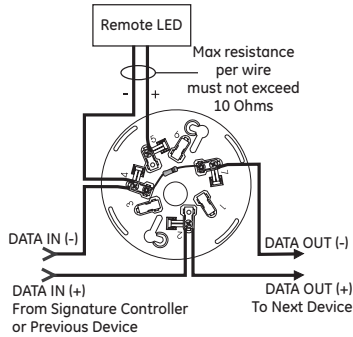

Isolator Detector Base, SIGA-IB, SIGA-IB4

This base includes a built-in line fault isolator for use on Class A circuits. A detector must be installed for it to operate. The isolator base does not support the SIGA-LED Remote LED.

The isolator operates as follows:

- a short on the line causes all isolators to open within 23 msec
- at 10 msec intervals, beginning on one side of the Class A circuit nearest the loop controller, the isolators close to provide the next isolator down the line with power
- when the isolator next to the short closes, it reopens within 10 msec.

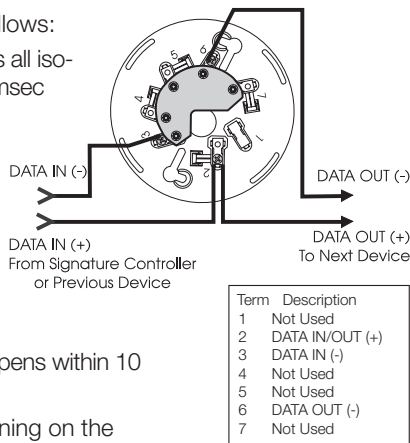

The process repeats beginning on the other side of the loop controller.

Relay Detector Base, SIGA-RB, SIGA-RB4

This base includes a relay. Normally Open or Normally Closed operation is selected during installation. The dry contact is rated for 1 amp (pilot duty) @ 30 Vdc. The relay's position is supervised to avoid accidentally jarring it out of position. The SIGA-RB can be operated as a control relay if programmed to do so at the control panel. The relay base does not support the SIGA-LED Remote LED.

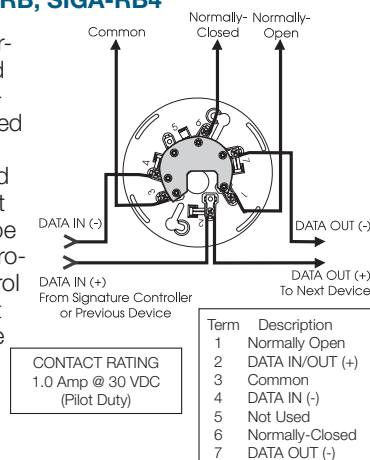

Audible Sounder Bases, Fire Mode

AB4GT, AB4G, AB4G-LF sounder bases

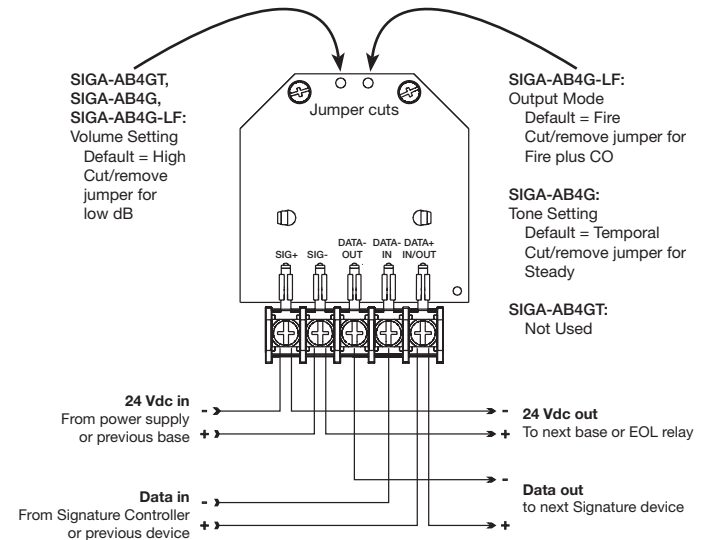

Audible Sounder Bases, Fire-plus-CO Mode

AB4GT and AB4G-LF sounder bases only.

These configurations require a SIGA-TCDR Temporal Pattern Generator to separate CO (TC4) and Fire (TC3) tone patterns.

Fire-plus-CO mode wiring for detector operation of bases

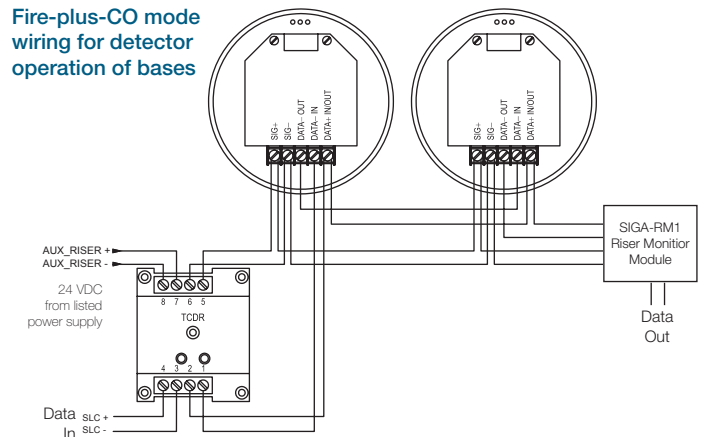

Fire-plus-CO mode wiring for detector and system operation of bases

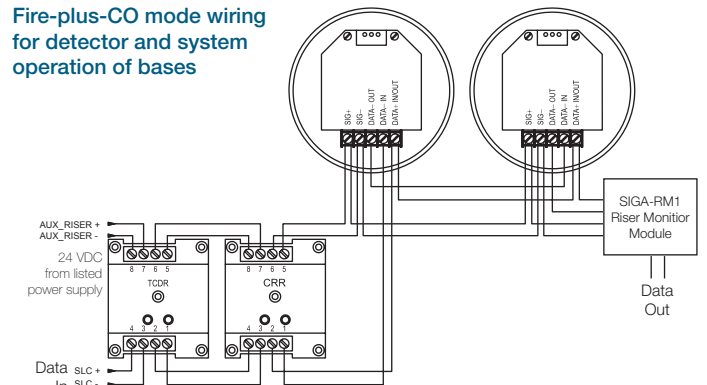



LIFE SAFETY & INCIDENT MANAGEMENT

Contact us...

Email: edwards.fire@fs.utc.com
 Web: Edwards-fire.com

EDWARDS is a UTC brand.
 1016 Corporate Park Drive
 Mebane, NC 27302

© 2016 United Technologies Corporation.
 All rights reserved.

Dimensions

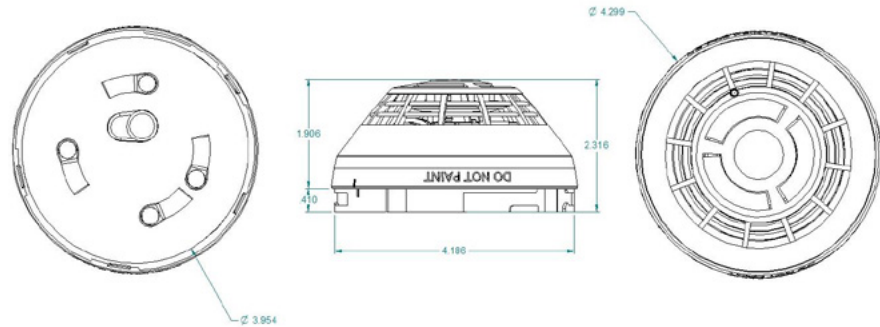

Specifications

Operating voltage	15.20 to 19.95 VDC
Normal operating current	32 μ A
Alarm current	32 μ A
Smoke Sensitivity Range	UL/ULC: 0.53 to 3.94 %/ft. (1.7 to 12.35 %/m) obscuration
Vibration level	10 to 35 Hz, with an amplitude of 0.01 in.
Wall mounting	12 in. (305 mm) max. from ceiling
Compatible bases	See Ordering Information
Compatible detector testers	Testfire 1000, Testfire 2000
Operating environment	32 to 120°F (0 to 49°C), 0 to 90% RH, noncondensing
Construction	High Impact Engineering Polymer, White
Storage temperature	-4 to 140°F (-20 to 60°C)
Environmental compensation	Automatic
UL CO alarm level	70 ppm 60 to 240 minutes
per UL 2034, CAN/CSA 6.19	150 ppm 10 to 50 minutes; 400 ppm 4 to 15 minutes
UL CO false alarm level	30 ppm 30 days
per UL 2034, CAN/CSA 6.19	70 ppm 60 minutes
Agency Listings, SIGA-PCD	UL 268, UL 2075. Evaluated to the CO alarm sensitivity limits of UL 2034.
Agency Listings, SIGA-PCD-CA	ULC Listed to CAN/ULC-S529 and CAN/CSA 6.19.

Warnings & Cautions

- This detector does not sense fires in areas where smoke cannot reach the detector. Smoke from fires in walls, roofs, or on the opposite side of closed doors may not reach the detector.
- Photoelectric detectors have a wide range of sensing capabilities, and are best suited for detecting slow, smoldering fires.
- Install per NFPA 72 *National Fire Alarm and Signaling Code*, NFPA 720 *Standard for the Installation of Carbon Monoxide (CO) Detection and Warning Equipment*, and UL 2075 *Standard for Gas and Vapor Detectors and Sensors*.

Ordering Information

Catalog Number	Description	Ship Wt. lbs (kg)
SIGA-PCD	Multisensor Smoke and CO Detector	0.4 (0.16)
SIGA-PCD-CA	Multisensor Smoke and CO Detector, Canadian Market	0.4 (0.16)

Compatible Bases

SIGA-SB	Detector Mounting Base - Standard	
SIGA-SB4	4-inch Detector Mounting Base c/w Trim Skirt	
SIGA-RB	Detector Mounting Base w/Relay	
SIGA-RB4	4-inch Detector Mounting Base w/Relay, c/w Trim Skirt	0.2 (.09)
SIGA-IB	Detector Mounting Base w/Fault Isolator	
SIGA-IB4	4-inch Detector Mounting Base w/ Fault Isolator, c/w Trim Skirt	
SIGA-LED	Remote Alarm LED (not for EN54 applications)	
SIGA-AB4G-LF	Low Frequency Audible (Sounder) Base for CO and Fire Detectors	0.3 (0.15)
SIGA-AB4GT	Audible (Sounder) Base for CO and Fire Detectors	0.3 (0.15)
SIGA-TCDR	Tone Generator for Detector Sounder Bases with CO mode	0.2 (0.1)
SIGA-TS4	Trim Skirt (supplied with 4-inch bases)	0.1 (.04)
SIGA-RTA	Detector Removal Tool	
SIGA-VA	Detector Cleaning Tool	