

**5 SIGNAGE MOUNTING DETAILS**  
SCALE: NONE

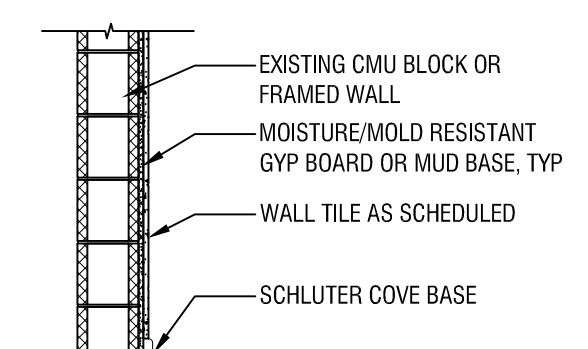

**4 TYP. TILE WALL DETAIL**  
SCALE: 1/2" = 1'-0"

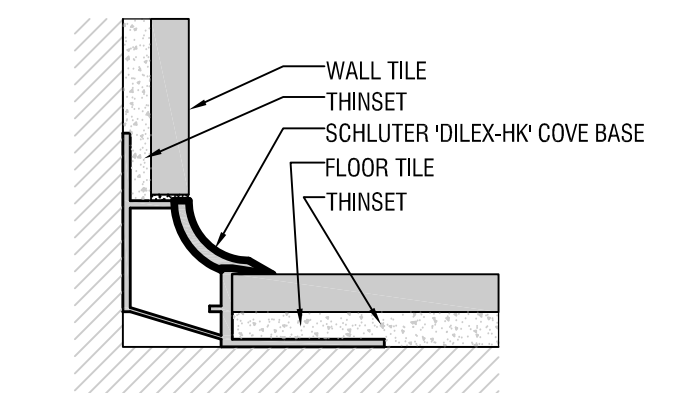

**3 TILE BASE DETAIL**  
SCALE: 6" = 1'-0"

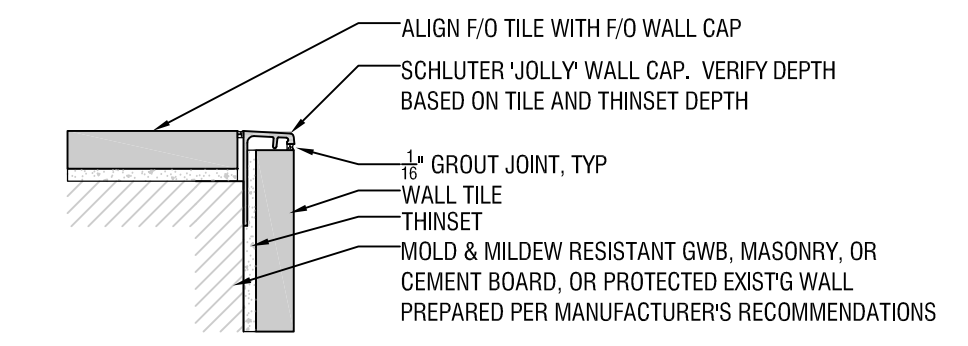

**2 OUTSIDE CORNER TILE DETAIL**  
SCALE: 6" = 1'-0"

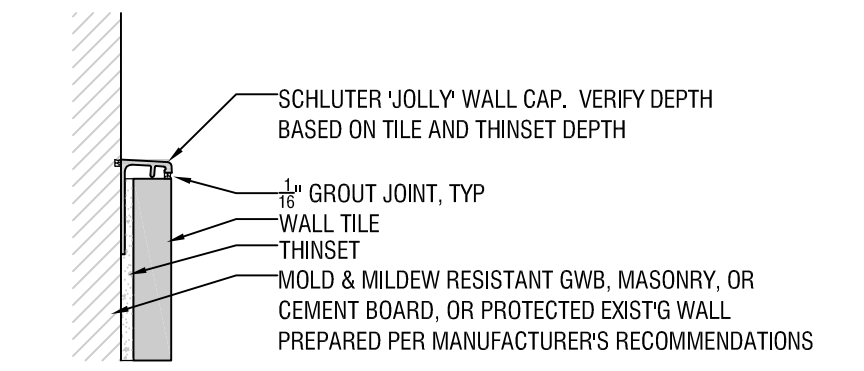

**1 TILE CAP DETAIL**  
SCALE: 6" = 1'-0"

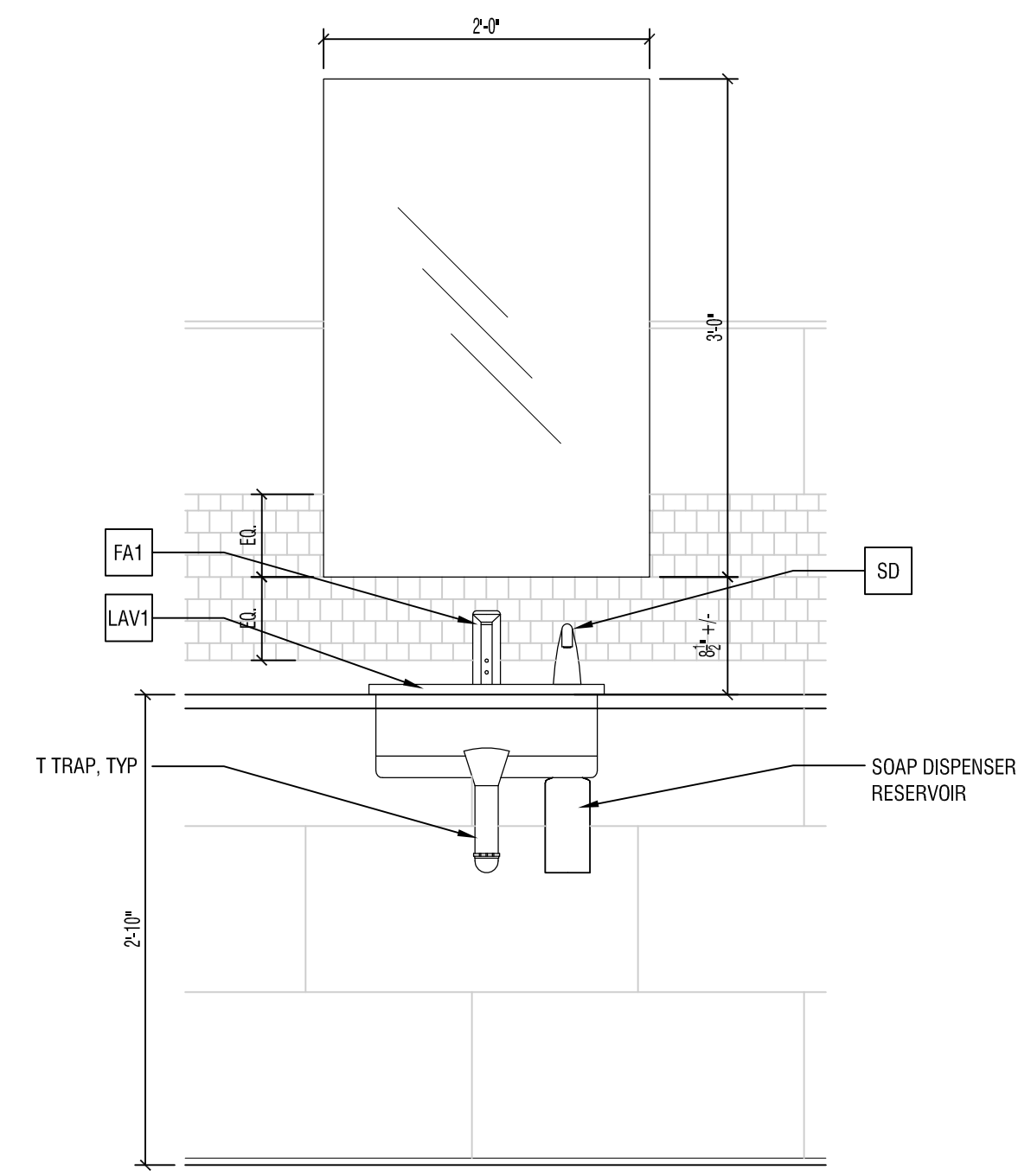

**8 TYP. LAVATORY DETAIL**  
SCALE: 1" = 1'-0"

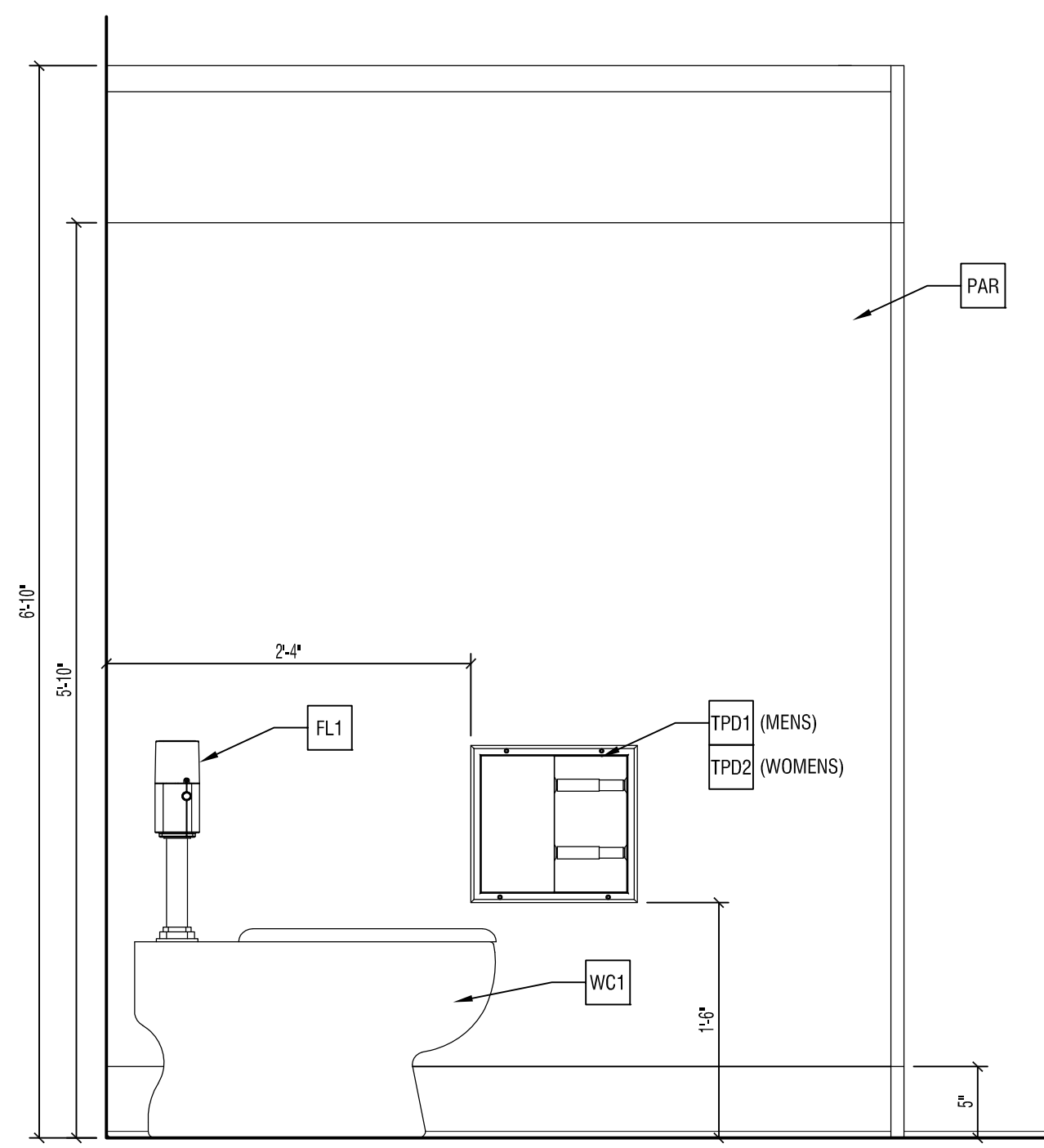

**7 TYP. STD WATER CLOSET DETAIL**  
SCALE: 1" = 1'-0"

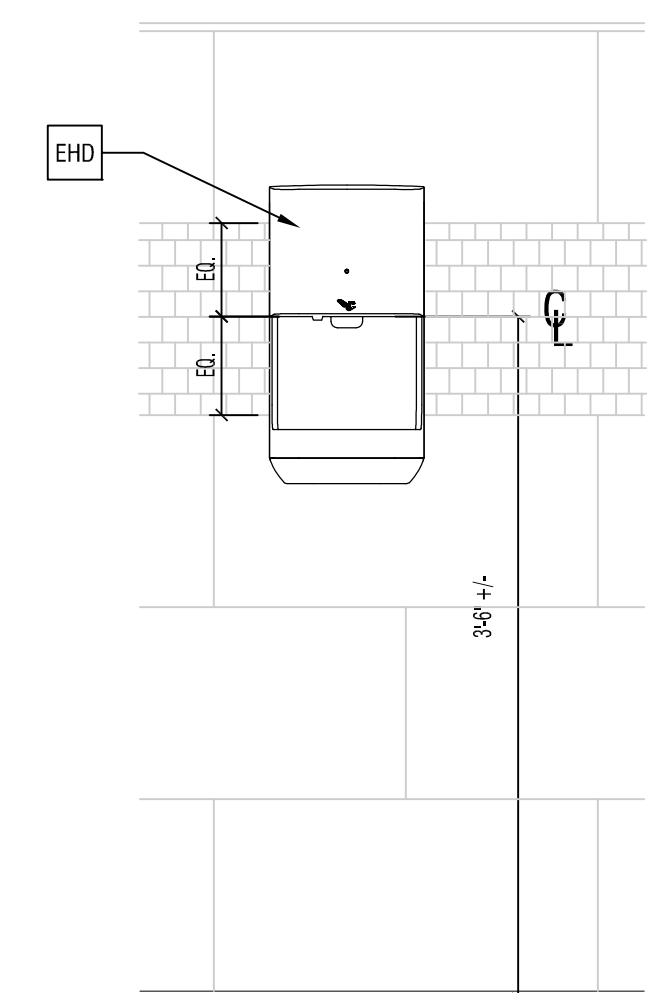

**9 TYP. SOAP DISPENSER DETAILS**  
SCALE: 1" = 1'-0"

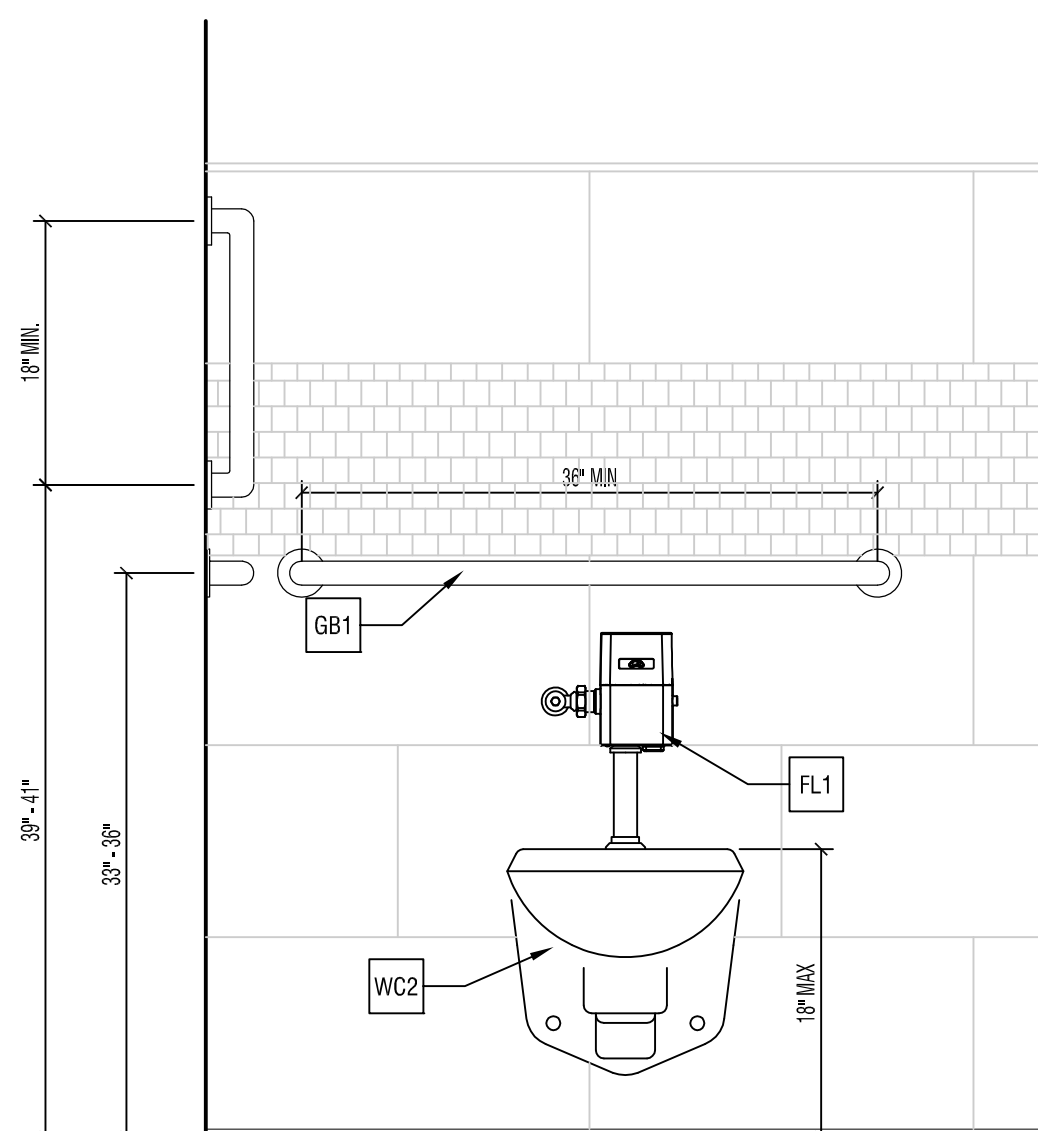

**6 TYP. ADA WATER CLOSET DETAILS**  
SCALE: 1" = 1'-0"

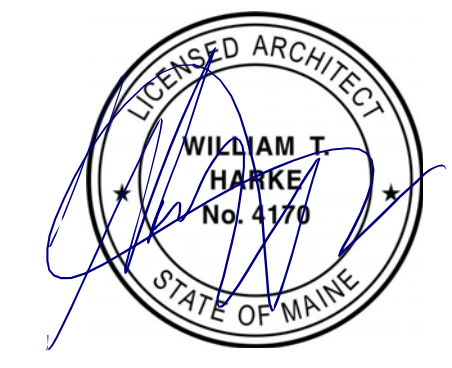
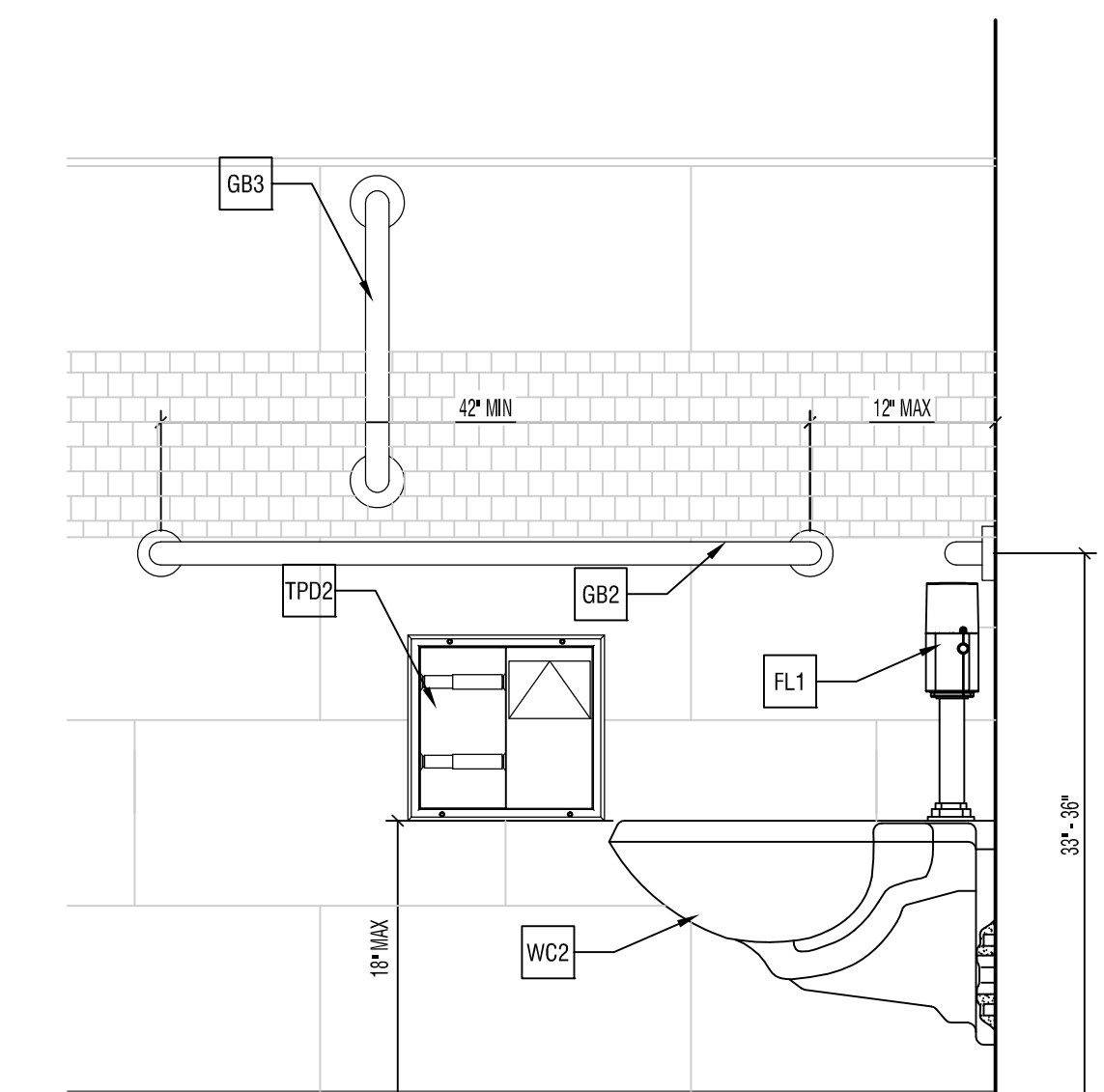

REV.	DESCRIPTION	DATE	BY	CK	APP	OWNER ENGINEER:	APPROVAL STAMP:	PE Stamp

<b>CMP ENGINEERING</b> CONFIDENTIAL, PROPRIETARY and TRADE SECRET INFORMATION Property of CENTRAL MAINE POWER CO.				<b>CENTRAL MAINE POWER</b>	
DR.	WITH & JME	SCALE:	AS NOTED	FILE:	2150037-045-TYPICAL NOTES.DWG
CK.	LABELLA	NO.			
APP.					
REV.	DATE	BY	DESCRIPTION	APP.	DATE
0.0A	04/27/2017	WITH	FOR PERMIT		

<b>PORTLAND SERVICE CENTER</b> <b>TYPICAL DETAILS</b> SHEET 8 OF 8			<b>MAINE</b>
<b>PORTLAND - 162 CANCO ROAD</b>			<b>0-0A</b>

ARCHD. CADD Drawings. DO NOT REVISE MANUALLY.