

ARCH D CADD Details, DO NOT REVISE MANUALLY.

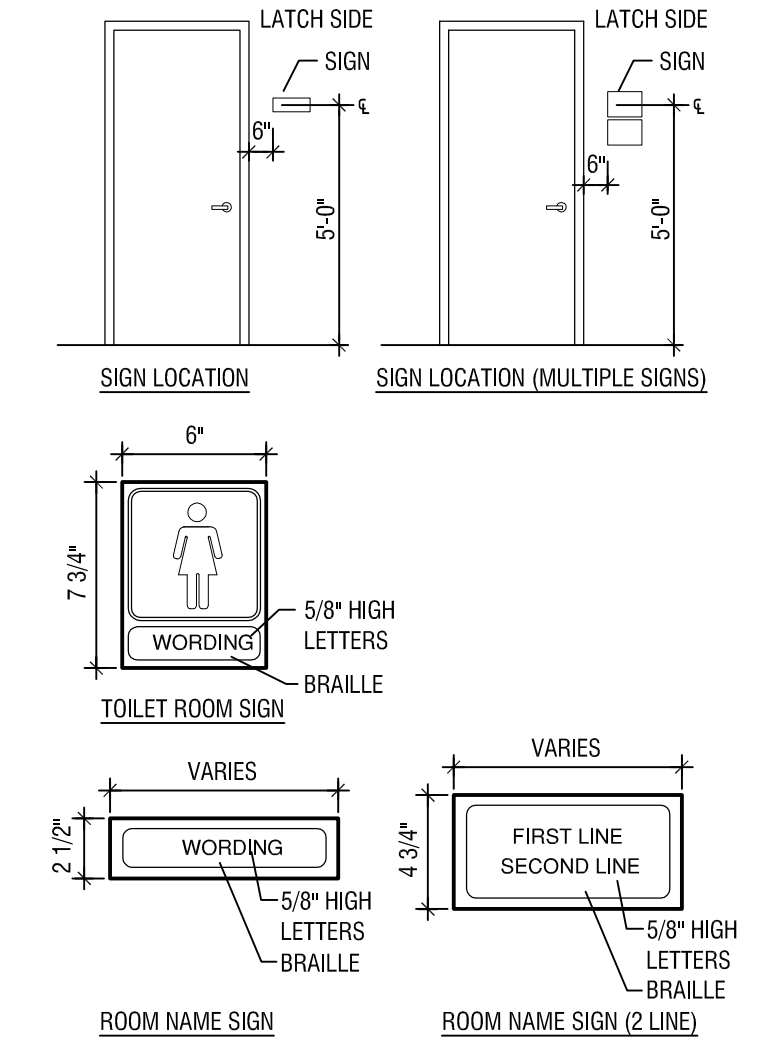

5 SIGNAGE MOUNTING DETAILS
SCALE: NONE

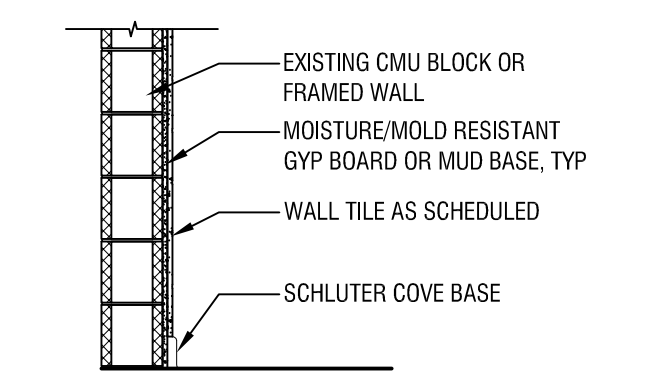

4 TYP. TILE WALL DETAIL
SCALE: 1/2" = 1'-0"

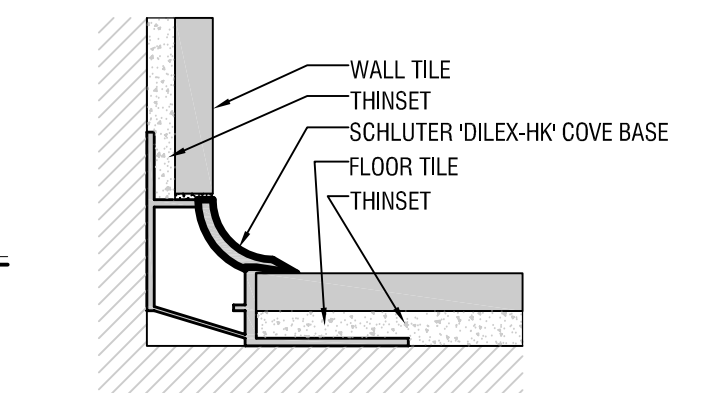

3 TILE BASE DETAIL
SCALE: 6" = 1'-0"

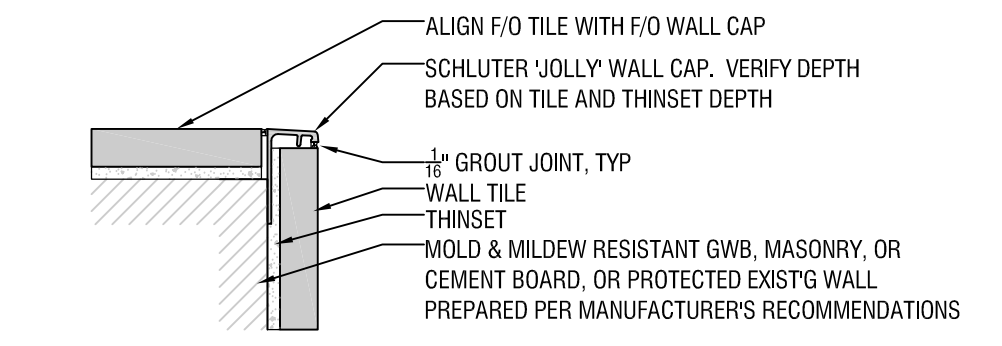

2 OUTSIDE CORNER TILE DETAIL
SCALE: 6" = 1'-0"

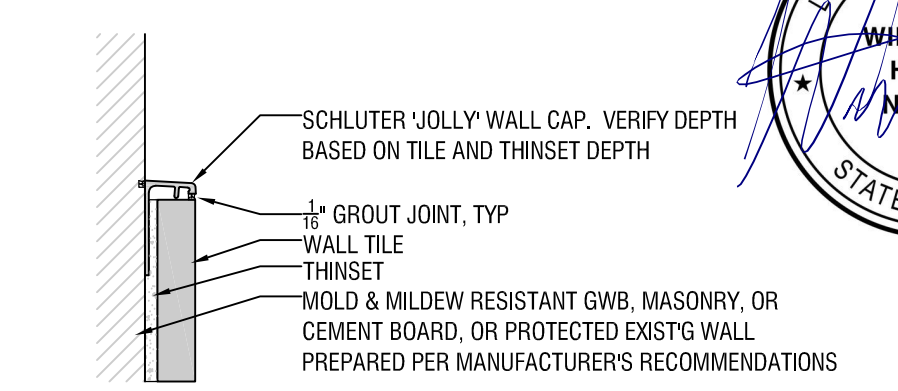

1 TILE CAP DETAIL
SCALE: 6" = 1'-0"

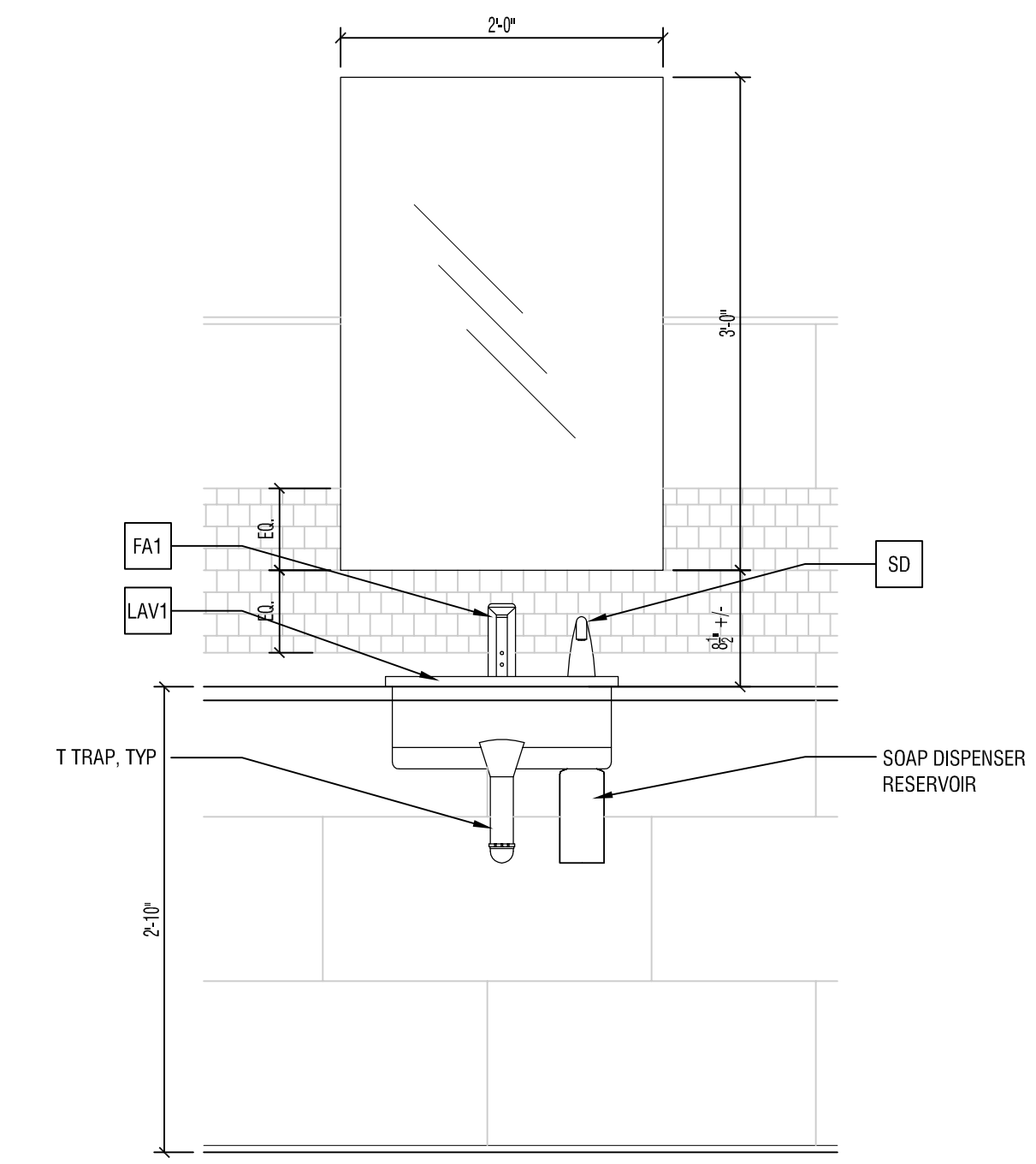

8 TYP. LAVATORY DETAIL
SCALE: 1" = 1'-0"

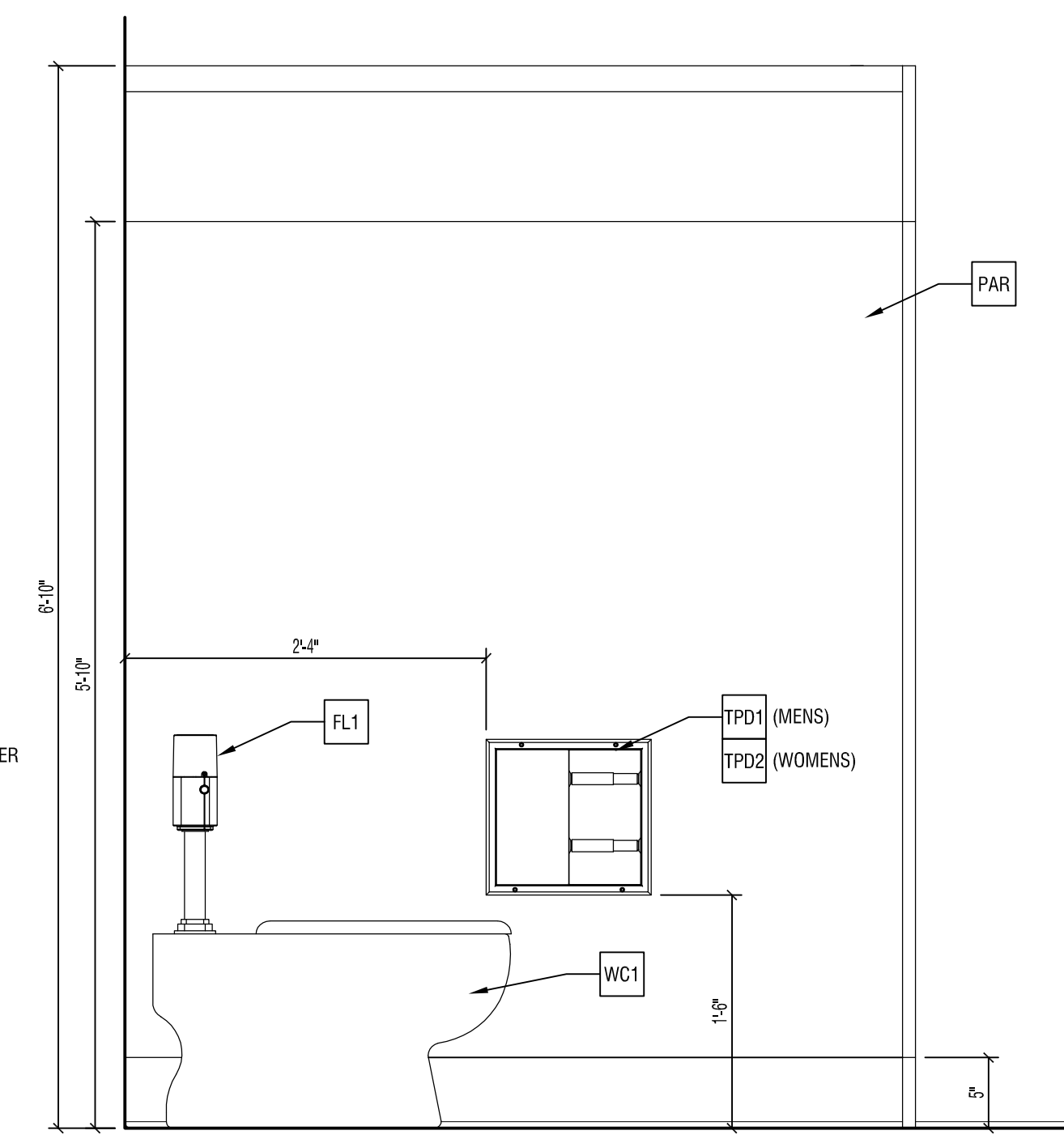

7 TYP. STD WATER CLOSET DETAIL
SCALE: 1" = 1'-0"

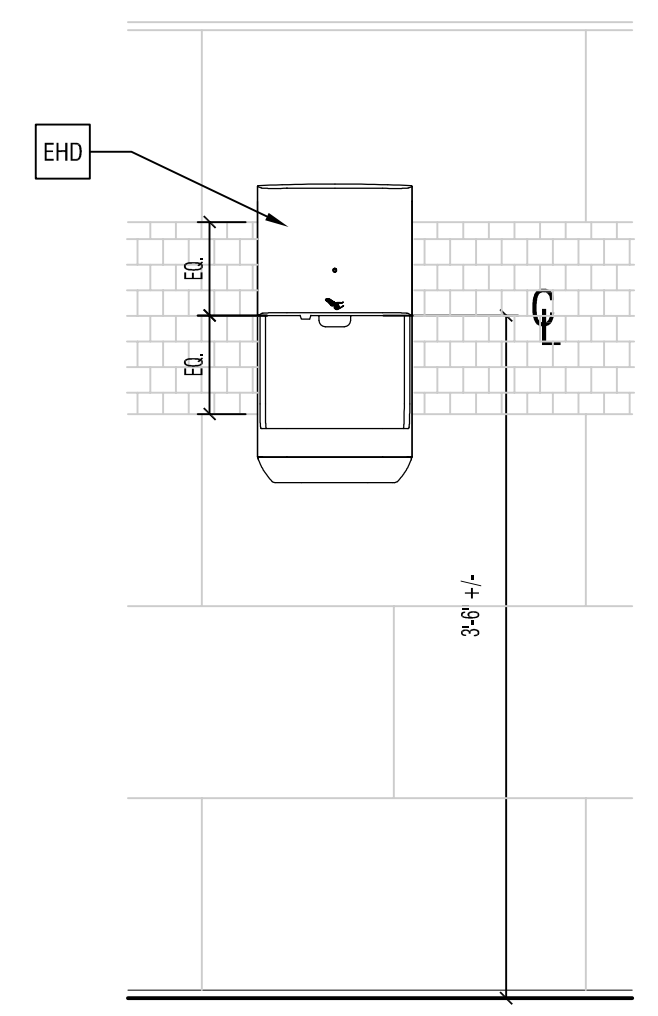

9 TYP. SOAP DISPENSER DETAILS
SCALE: 1" = 1'-0"

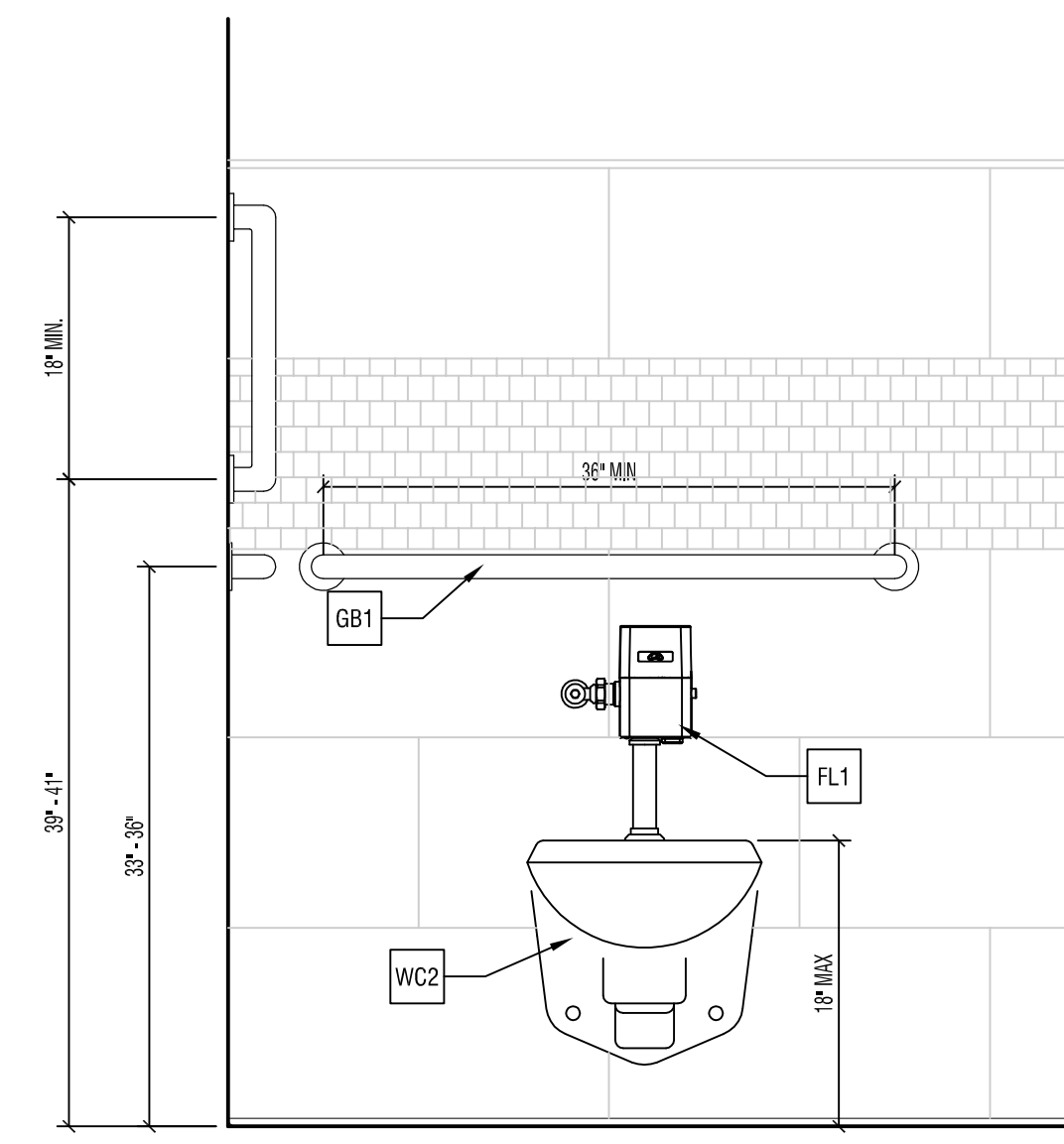

6 TYP. ADA WATER CLOSET DETAILS
SCALE: 1" = 1'-0"

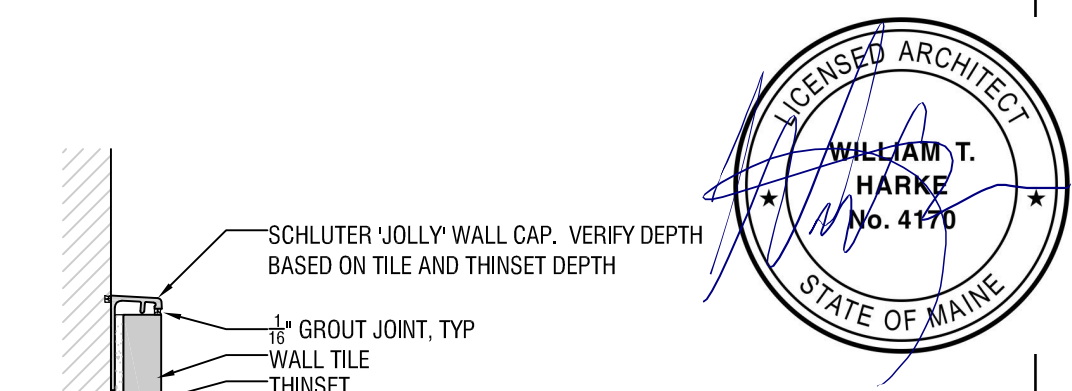
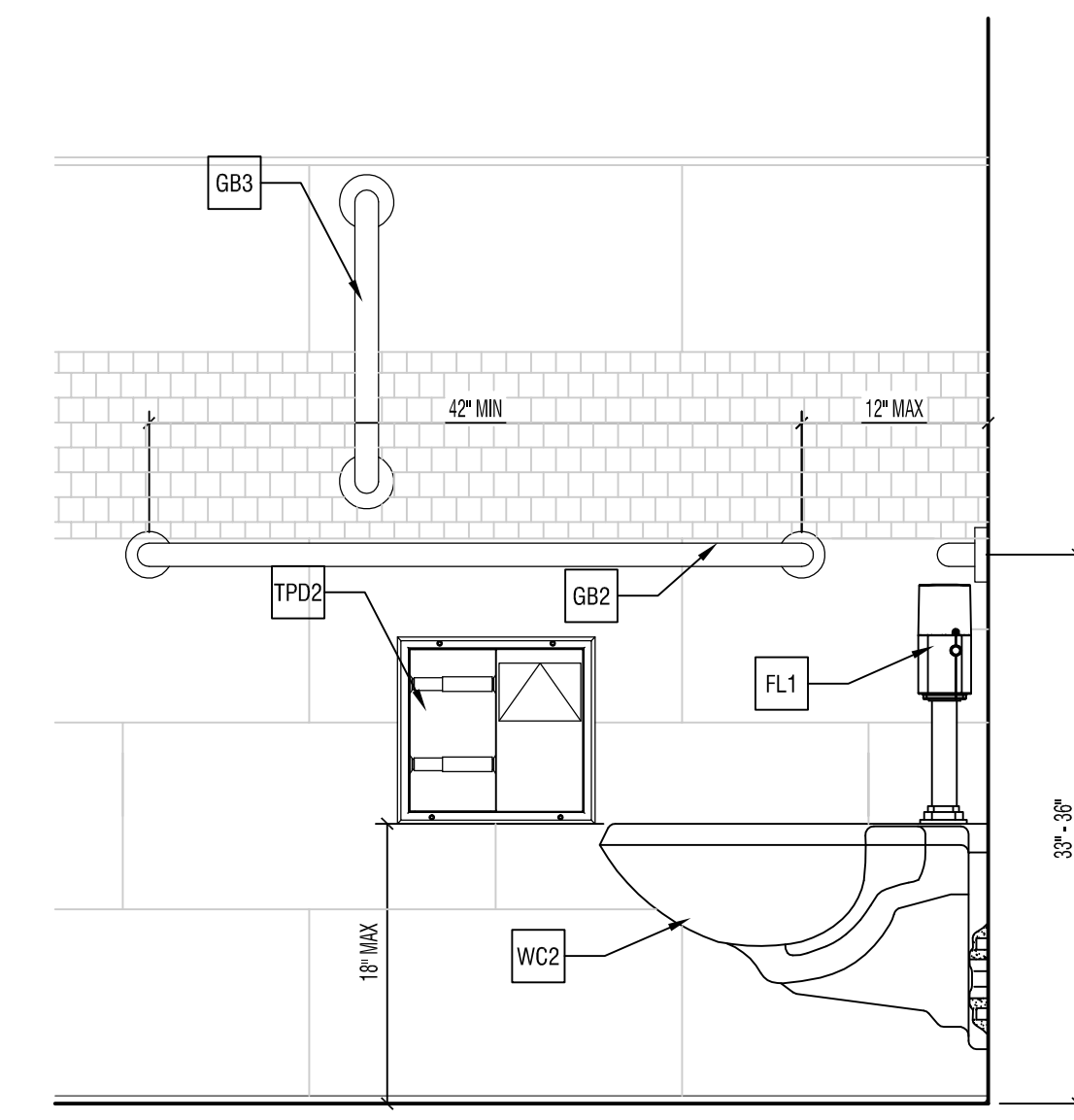

REV.	DESCRIPTION	DATE	BY	CK	APP	OWNER ENGINEER:	APPROVAL STAMP:	PE Stamp

DRAWING PREPARED BY:		ACCEPTED BY OE:	
LABELIA Architects, PLLC			

CMP ENGINEERING CONFIDENTIAL, PROPRIETARY and TRADE SECRET INFORMATION Property of CENTRAL MAINE POWER CO.					
2.0A	02-16-2017	WTH	FOR PERMIT (3RD FLOOR)		
1.0A	10-31-2016	WTH	FOR PERMIT		
REV.	DATE	BY	DESCRIPTION	APP.	DATE

PORTLAND SERVICE CENTER TYPICAL DETAILS	
SHEET 14 OF 14	
PORTLAND - 162 CANCO ROAD MAINE	SCALE: AS NOTED FILE: 2116007.045-TYPICAL NOTES.DWG
DR. WTH & JME CK. LABELIA APP. -- NO.	REV. NO. A-500 0-0A