

GENERAL CONSTRUCTION NOTES

- A. EXISTING CONDITIONS ARE TAKEN FROM FIELD OBSERVATIONS AND PRIOR CONSTRUCTION DOCUMENTS WHEN AVAILABLE AND ARE NOT GUARANTEED. CONTRACTOR SHALL FIELD VERIFY ALL EXISTING CONDITIONS PRIOR TO BID. NO ALLOWANCE WILL BE MADE FOR ADDITIONAL COSTS DUE TO CONTRACTORS FAILURE TO VERIFY EXISTING CONDITIONS AND DIMENSIONS.
- B. WHEN EXISTING CONSTRUCTION WHICH IS TO REMAIN IS DAMAGED DURING THE COURSE OF CONSTRUCTION AS A RESULT OF CONTRACTORS WORK, IT SHALL BE REPAIRED AND/OR REPLACED WITH SIMILAR OR LIKE MATERIALS, SUBJECT TO ARCHITECTS APPROVAL AND WITHOUT COMPENSATION.
- C. ALL WORK INDICATED ON THIS DRAWING SHALL BE DONE UNDER THE GENERAL CONSTRUCTION CONTRACT UNLESS OTHERWISE NOTED.
- D. G.C. TO PROVIDE SLAB INFILL (2" MIN. V.L.F.) AS NECESSARY FOR A LEVEL FINISH OVER EXISTING STRUCTURAL CONCRETE SLAB. PATCH, PREP AND REPAIR SUB FLOORS AS NECESSARY TO RECEIVE NEW FLOORING. PROVIDE NEW FLOORING AS SCHEDULED. PROVIDE TRANSITION STRIPS, TERMINATION BARS AND/OR THRESHOLDS AT ALL CHANGES IN FLOORING MATERIALS AND/OR DOORWAYS. (METAL TERM BARS, VINYL REDUCERS, ETC.)

KEYNOTES

- 1 PROVIDE SOLID PHENOLIC TOILET PARTITION PANELS FLOOR MOUNTED, OVERHEAD BRACED. PROVIDE PRIVACY HINGE AT DOORS AND CONTINUOUS BRACKETS AT ALL PANEL AND WALL CONNECTIONS. TYPICAL
- 2 INSTALL DOOR, FRAME AND ASSOCIATED HARDWARE.
- 3 MIRROR 22"x36"
- 4 TOILET TISSUE DISPENSER TO BE PROVIDED - BOBRICK B-386
- 5 SOAP DISPENSER TO BE PROVIDED - BOBRICK B-826.18
- 6 HAND DRYER UNIT - TOTO HDR101#WH
- 7 PROVIDE PIPE PROTECTION
- 8 PROVIDE NEW ADA COMPLIANT GRAB BARS - BOBRICK 5191
- 9 SHOWER SHELF, MECHANICAL FASTENED WITH SS HARDWARE TYP. BRADLEY 7510
- 10 MOISTURE AND MOLD RESISTANT BENCH, USE SS HARDWARE. TYP SEE DETAIL 9/A-202
- 11 TOILET TISSUE DISPENSER AND SANITARY NAPKIN DISPOSAL - AMERICAN SPECIALTIES 4813
- 12 24" x 36" ADA TILT MIRROR BY G.C.
- 13 PROVIDE HAND SHOWER - SPEAKMAN SM-5480-ADA
- 14 PROVIDE SHOWER HEAD AND CONTROLS - SPEAKMAN SM-5410
- 15 6" X 24" OLYMPIA FRENZE WALL TILE
- 16 12" X 12-1/2" OLYMPIA OJ.J.W.GRY.BL.1RR ACCENT WALL TILE
- 17 SCHLUTER BULLNOSE EDGING
- 18 PRIME AND PAINT WALL - BENJAMIN MOORE HC-27 MONTEREY WHITE
- 19 MOLD RESISTANT GYP CEILING AT 9'-0" A.F.F. W/ 2" X 2" CEILING TILE - OLYMPIA TILE QUEBEC
- 20 MOUNT HOOKS WITH STAINLESS STEEL HARDWARE, TYP. BRADLEY 912
- 21 2X2 A.C.T. CEILING AT 9'-0" A.F.F. - ARMSTRONG ULTIMA#1936
- 22 2" X 4" WALL TILE - OLYMPIA
- 23 COVE WALL BASE AS SCHEDULED
- 24 KOHLER FREEWILL SHOWER INSERT

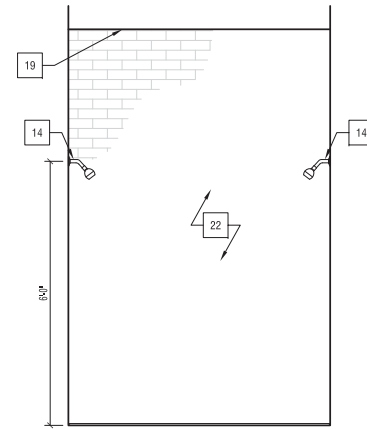

7 2ND FLR SHOWER STALL ELEV
ROOM 2N006
A-204 1/2"=1'-0"

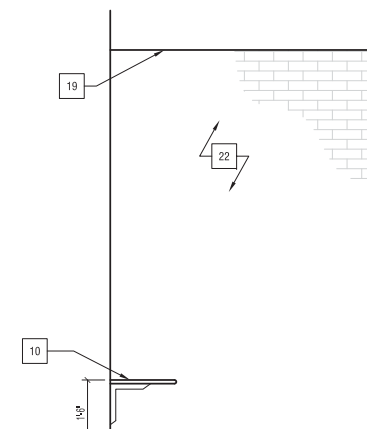

4 2ND FLR SHOWER ELEV
ROOM 2N006
A-204 1/2"=1'-0"

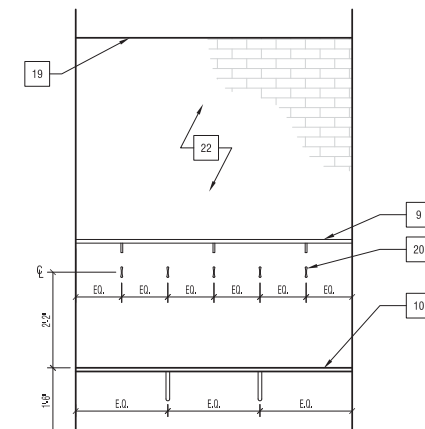

1 2ND FLR SHOWER ELEV
ROOM 2N006
A-204 1/2"=1'-0"

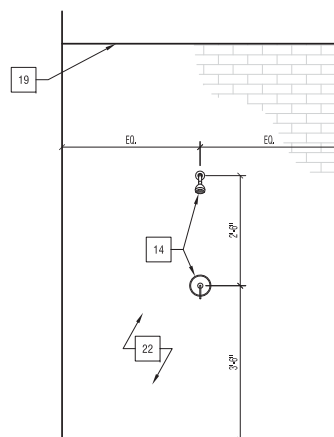

8 2ND FLR SHOWER STALL ELEV
ROOM 2N006
A-204 1/2"=1'-0"

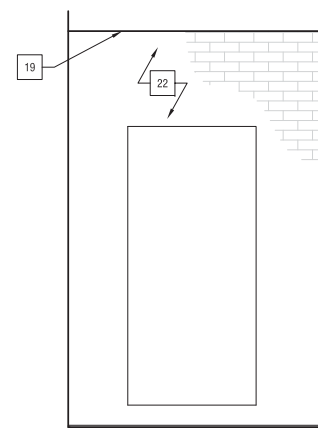

5 2ND FLR SHOWER STALL ELEV
ROOM 2N006
A-204 1/2"=1'-0"

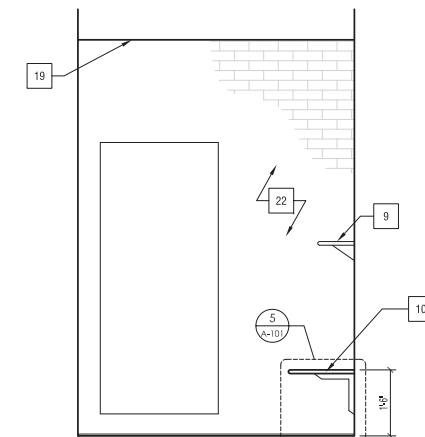

2 2ND FLR SHOWER ELEV
ROOM 2N006
A-204 1/2"=1'-0"

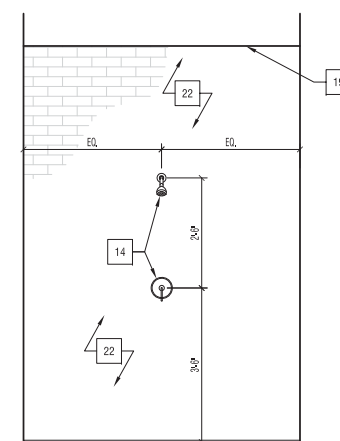

6 2ND FLR SHOWER STALL ELEV
ROOM 2N006
A-204 1/2"=1'-0"

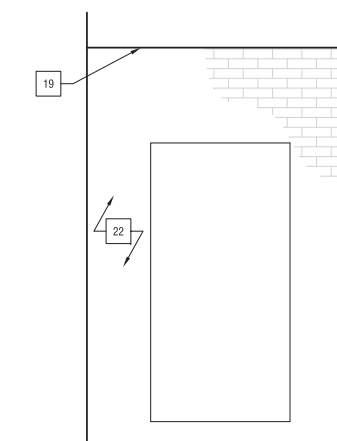

3 2ND FLR SHOWER ELEV
ROOM 2N006
A-204 1/2"=1'-0"



REV.	DESCRIPTION	DATE	BY	CK	APP	OWNER ENGINEER	APPROVAL STAMP:	PE Stamp
1-0A	FOR PERMIT	10.31.16						
0-0A	FOR FINAL REVIEW	10.14.16						

CMP ENGINEERING CONFIDENTIAL, PROPRIETARY and TRADE SECRET INFORMATION Property of CENTRAL MAINE POWER CO.				CENTRAL MAINE POWER		PORTLAND SERVICE CENTER MEN'S RESTROOM ELEVATIONS	
DRAWING PREPARED BY: LABELIA Assoc./Inc./D.P.C.				ACCEPTED BY OE:		SHEET 10 OF 14	
14-A 10-31-2016 WTH FOR PERMIT				SCALE: 1/2" = 1'-0"		PORTLAND - 162 CANCO ROAD MAINE	
REV.	DATE	BY	DESCRIPTION	APP.	DATE	DR. WTH & JME CK. LABELIA APP. - DATE: -	

CADDD Drawings, DO NOT REUSE MANUALLY.
 ARCH-D

A-204
 REV. 0-0A