

4 TYP TILE WALL DETAIL
SCALE: 1/2" = 1' - 0"

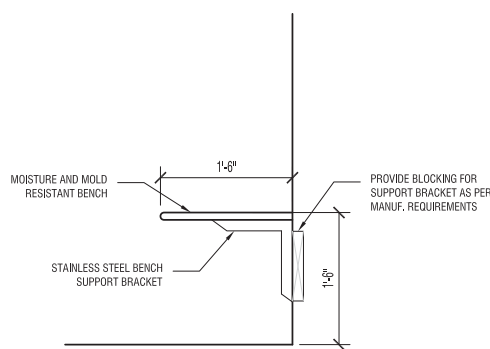

5 SHOWER ROOM BENCH DETAIL
SCALE: 1/4" = 1' - 0"

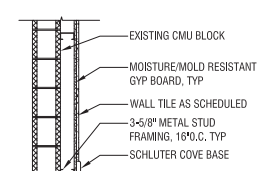

6 URINAL WALL DETAIL
SCALE: 1/2" = 1' - 0"

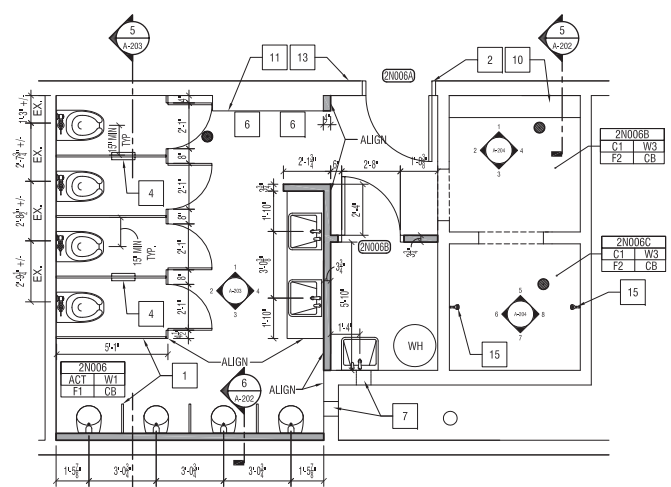

1 2ND FLR MENS RESTROOM PL ROOM 2N006
SCALE: 1/4" = 1' - 0"

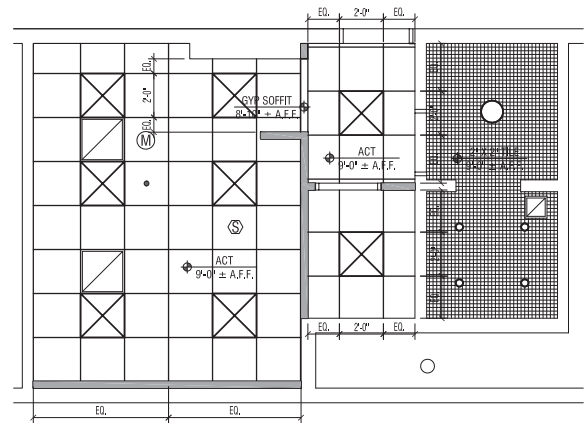

2 2ND FLR MENS RESTROOM RCP ROOM 2N006
SCALE: 1/4" = 1' - 0"

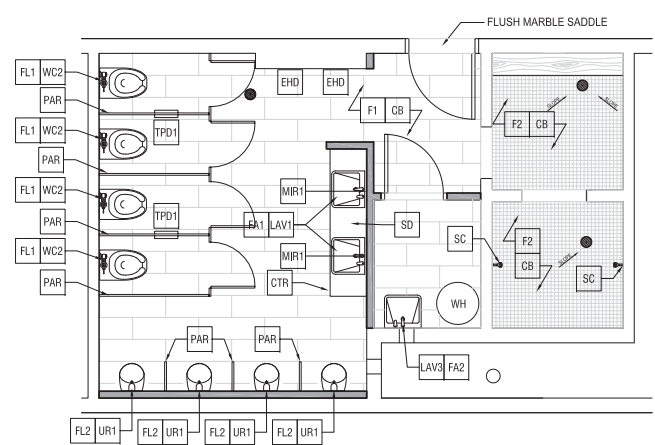

3 1ND FLR MENS RESTROOM FINISH PL ROOM 2N006
SCALE: 1/4" = 1' - 0"

Keynote	LOCATION	MANUFACTURER	MODEL/NAME	SIZE
PAINT				
P1	PRIMARY WALL	BENJAMIN MOORE		
A1	ACCENT 1	BENJAMIN MOORE		
A2	ACCENT 2	BENJAMIN MOORE		
CEILING				
ACT	ACT	ARMSTRONG	ULTIMA #1936	2" x 2"
TILE				
F1	FLOOR (MAIN)	OLYMPIA TILE	NEW LENGO	12" x 48"
F2	FLOOR (SHOWER)	OLYMPIA TILE	QUEBEC	1" x 1"
W1	WALL (MAIN)	OLYMPIA TILE	RRENZE	6" x 24"
W2	WALL (ACCENT)	OLYMPIA TILE	QJ.JW.GRY.BL.1RR	
W3	WALL (SHOWER)	OLYMPIA TILE		2" x 4"
C1	CEILING (SHOWER)	OLYMPIA TILE	QUEBEC	2x2
CB	COVE BASE	SCHLUTER	DILEX-HK	
WT	WALL TRIM	SCHLUTER	JOLLY	
GROUT				
--	FLOOR	FLEXITILE	JAVA	
--	WALL	FLEXITILE	SNOW WHITE	
FIXTURES				
WC1	TOILET (FLOOR MTD)	TOTO	CT705ELN#01	
WC2	TOILET (WALL MTD)	TOTO	CT708E#01	
FL1	FLUSHOMETER	TOTO	TET1LA32#CP	
UR1	URINAL	TOTO	UT105UV#01	
FL2	FLUSHOMETER	TOTO	TELSUA11#SS	
LAV1	LAVATORY	MARZ	YD MEDIUM SLIDE	
LAV2	LAVATORY	KHOLER	K-1997-RI-0	
LAV3	LAVATORY	AMERICAN STANDARD	CAST IRON #7892.008	
FA1	FAUCET	KOHLER	K-7516-CP	
FA2	FAUCET	AMERICAN STANDARD	8344.012	
SD	SOAP DISPENSOR	BOBRICK	B-826.18	
EHD	HAND DRYER	TOTO	HDR101#WH	
SC	SHOWER CONTROL & HEAD	SPEAKMAN	SM-5410	
HS	HAND SHOWER (ADA)	SPEAKMAN	SM-5480-ADA	
SS	SHOWER STALL	KOHLER	K-12101-C-0	
ACCESSORIES				
PAR	PARTITIONS	GENERAL PARTITIONS	POWDER COATED	
CTR	COUNTERS	CORIAN		
TPD1	TOILET TISSUE (MEN)	BOBRICK	B-386	
TPD2	TOILET TISSUE (WOMEN)	AMERICAN SPECIALTIES	4813	
SH	SHOWER SHELF (DRESSING AREA)	BRADLEY	7510	
HKS	HOOKS (DRESSING AREA)	BRADLEY	912	
BNH	SHOWER BENCH (ADA)	BOBRICK	B-5191	
GB1	GRAB BARS (TOILET-REAR)	BOBRICK	B-5806.99x36	
GB2	GRAB BARS (TOILET-SIDE)	BOBRICK	B-5806.99x42	
GB3	GRAB BARS (TOILET-VERTICAL)	BOBRICK	B-5806.99x18	
GB4	GRAB BARS (SHOWER)	(SEE TOILET BARS)		
MIR1	MIRROR (MEN)			
MIR2	MIRROR (WOMEN)			
MIR3	TILT MIRROR (ADA)			

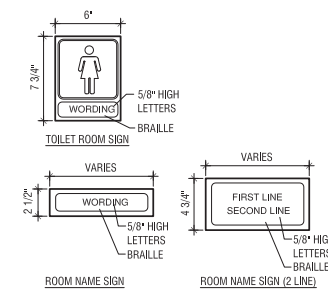
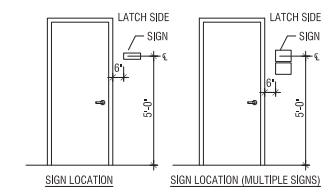

SIGNAGE MOUNTING DETAILS

GENERAL FINISH NOTES

- ALL FINISH PRODUCTS ARE TO BE INSTALLED IN ACCORDANCE WITH CONTRACT SPECIFICATIONS AND MANUFACTURERS INSTRUCTIONS. REFER TO SPECIFICATIONS AND FINISH DETAILS FOR ADDITIONAL INFORMATION ON INSTALLATION OF SPECIFIED MATERIALS.
- APPLY PAINT TO ITEMS INCLUDING BUT NOT LIMITED TO: BEAMS, DOOR FRAMES - BOTH SIDES, GLAZING FRAMES IN DOORS AND IN WALLS.
- PROVIDE TRANSITION STRIPS AT THE MIDDLE OF CLOSED DOOR. REFER TO DETAILS.
- FOR ALL RENOVATED AREAS REQUIRING FINISH WORK REMOVE, PROTECT AND REINSTALL MOVABLE EQUIPMENT. REINSTALL IN ORIGINAL LOCATION, OR AS NOTED ON DRAWINGS, COORDINATE WITH OWNER.
- FLOORING INSTALLER IS TO FIELD VERIFY ALL CONTROL JOINT LOCATIONS IN CONCRETE SLAB. LOCATE CONTROL JOINTS IN EXISTING/NEW FLOOR FINISH MATERIAL DIRECTLY ABOVE SLAB JOINTS OR AS RECOMMENDED BY FLOORING MATERIAL MANUFACTURER.
- ALL CEILING TO BE 9'-0" A.F.F.

ROOM FINISH KEY



FINISH PLAN LEGEND

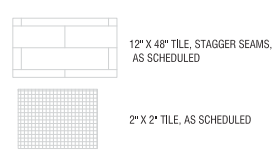

CEILING LEGEND

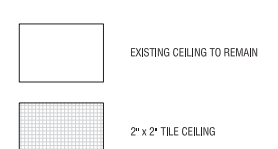

GENERAL CONSTRUCTION NOTES

- EXISTING CONDITIONS ARE TAKEN FROM FIELD OBSERVATIONS AND PRIOR CONSTRUCTION DOCUMENTS WHEN AVAILABLE AND ARE NOT GUARANTEED. CONTRACTOR SHALL FIELD VERIFY ALL EXISTING CONDITIONS PRIOR TO BID. NO ALLOWANCE WILL BE MADE FOR ADDITIONAL COSTS DUE TO CONTRACTORS FAILURE TO VERIFY EXISTING CONDITIONS AND DIMENSIONS.
- WHEN EXISTING CONSTRUCTION WHICH IS TO REMAIN IS DAMAGED DURING THE COURSE OF CONSTRUCTION AS A RESULT OF CONTRACTORS WORK, IT SHALL BE REPAIRED AND/OR REPLACED WITH SIMILAR OR LIKE MATERIALS, SUBJECT TO ARCHITECTS APPROVAL AND WITHOUT COMPENSATION.
- ALL WORK INDICATED ON THIS DRAWING SHALL BE DONE UNDER THE GENERAL CONSTRUCTION CONTRACT UNLESS OTHERWISE NOTED.
- G.C. TO PROVIDE SLAB INFILL (2" MIN. V.L.F.) AS NECESSARY FOR A LEVEL FINISH OVER EXISTING STRUCTURAL CONCRETE SLAB. PATCH, PREP AND REPAIR SUB FLOORS AS NECESSARY TO RECEIVE NEW FLOORING. PROVIDE NEW FLOORING AS SCHEDULED. PROVIDE TRANSITION STRIPS, TERMINATION BARS AND/OR THRESHOLDS AT ALL CHANGES IN FLOORING MATERIALS AND/OR DOORWAYS. (METAL TRIM BARS, VINYL REDUCERS, ETC.)
- ALL PRODUCTS INCLUDING BUT NOT LIMITED TO GYP BOARD AND PAINT TO BE MOLD AND MILDEW RESISTANT

KEYNOTES

- PROVIDE SOLID PHENOLIC TOILET PARTITION PANELS FLOOR MOUNTED, OVERHEAD BRACED. PROVIDE PRIVACY HINGE AT DOORS AND CONTINUOUS BRACKETS AT ALL PANEL AND WALL CONNECTIONS, TYPICAL.
- INSTALL DOOR, FRAME AND ASSOCIATED HARDWARE.
- MIRROR 22"x36"
- TOILET TISSUE DISPENSER TO BE PROVIDED - BOBRICK B-386
- SOAP DISPENSER TO BE PROVIDED - BOBRICK B-826.18
- HAND DRYER UNIT - TOTO HDR101#WH
- CLOSE EXISTING HVAC OPENING AND RELOCATE OPENING
- PROVIDE NEW ADA COMPLIANT GRAB BARS - BOBRICK B-5806
- SHOWER SHELF W/ HOOKS, MECHANICALLY FASTENED WITH SS HARDWARE TYP. BRADLEY 7510 AND 912
- MOISTURE AND MOLD RESISTANT BENCH, USE SS HARDWARE TYP
- PATCH WALL AND PREPARE TO RECEIVE SCHEDULED FINISH AS REQUIRED BY MANUFACTURE
- TOILET TISSUE DISPENSER AND SANITARY NAPKIN DISPOSAL - AMERICAN SPECIALTIES 4813
- PROVIDE ROOM SIGNAGE
- PROVIDE BLOCKING FOR ADA GRAB BARS
- PROVIDE SHOWER HEAD - SPEAKMAN SM-5410
- SHOWER LIGHT - KOHLER K-16665-CP

FLOOR PLAN LEGEND

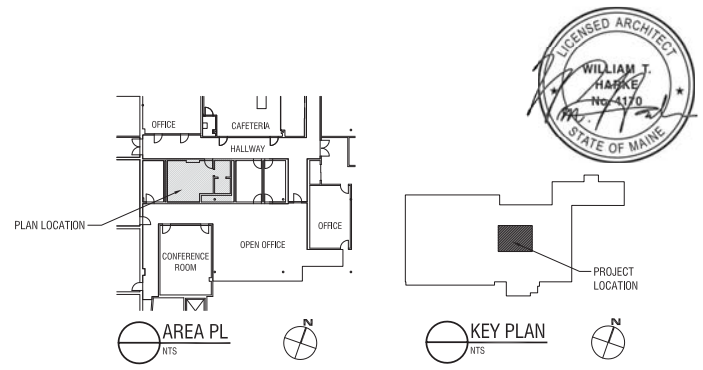
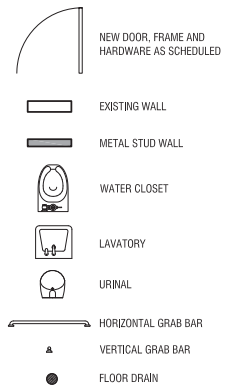

REV.	DESCRIPTION	DATE	BY	CK	APP	OWNER ENGINEER:	APPROVAL STAMP:	PE Stamp
1-0A	FOR PERMIT	10.31.16				DRAWING PREPARED BY: LABELLA Architects, P.C.	ACCEPTED BY OE:	
0-0A	FOR FINAL REVIEW	10.14.16						

REV.	DATE	BY	DESCRIPTION	APP.	DATE
1-0A	10-31-2016	WTH	FOR PERMIT		

CMP ENGINEERING CONFIDENTIAL, PROPRIETARY and TRADE SECRET INFORMATION Property of CENTRAL MAINE POWER CO.			PORTLAND SERVICE CENTER MEN'S RESTROOM FLOOR PLAN AND RCP		
			SHEET 4 OF 14		
PORTLAND - 162 CANCO ROAD		MAINE			
DR.	WTH & JME	SCALE:	1/4" = 1'-0"	FILE:	RESTROOM RENOVATION PLAN/LOG
CK.	LABELLA	NO.			
APP.					
REV.					

ARCHD CADD Drawing. DO NOT REUSE MANUALLY.

