

The Park Danforth

RENOVATIONS AND ADDITIONS

777 Stevens Ave
 Portland, ME 04103

NO.	DESCRIPTION	DATE
2	Addendum #2	06/25/15

CONTENT: PLAN DETAILS	
DRAWN BY:	Author
PROJECT NO:	13-059-00
DATE:	06/05/2015
REVISED:	
SCALE:	3" = 1'-0"
A5.8	
Project Phase 100% CONSTRUCTION DOCUMENTS	
COPYRIGHT © 2015 BY LAVALLEE BRENSINGER PROFESSIONAL ASSOCIATION. ALL RIGHTS RESERVED. NO REPRODUCTION WITHOUT PERMISSION.	

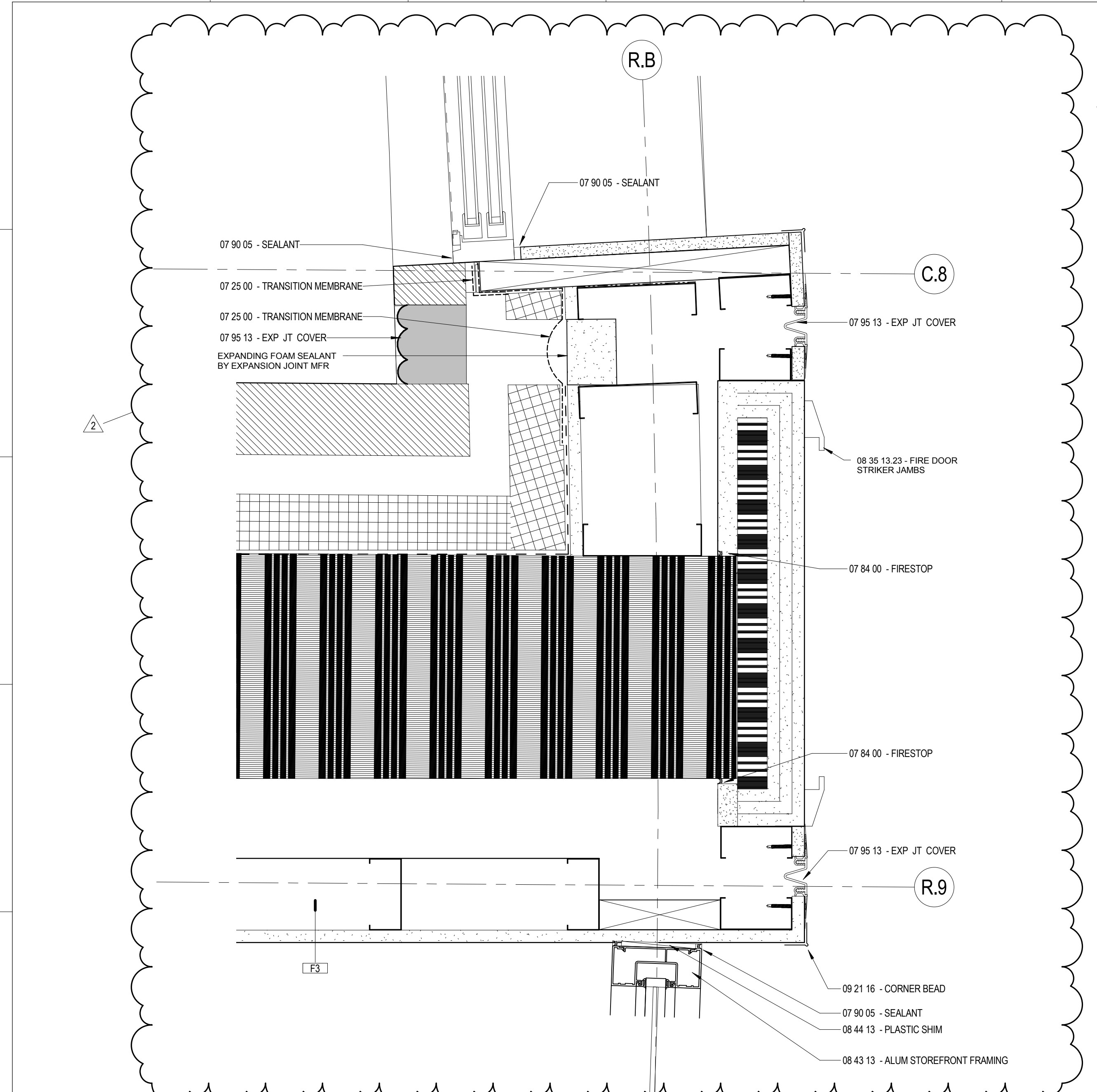

E1 PLAN DETAIL @ WON DOOR RECEIVER
 A5.8 3" = 1'-0"

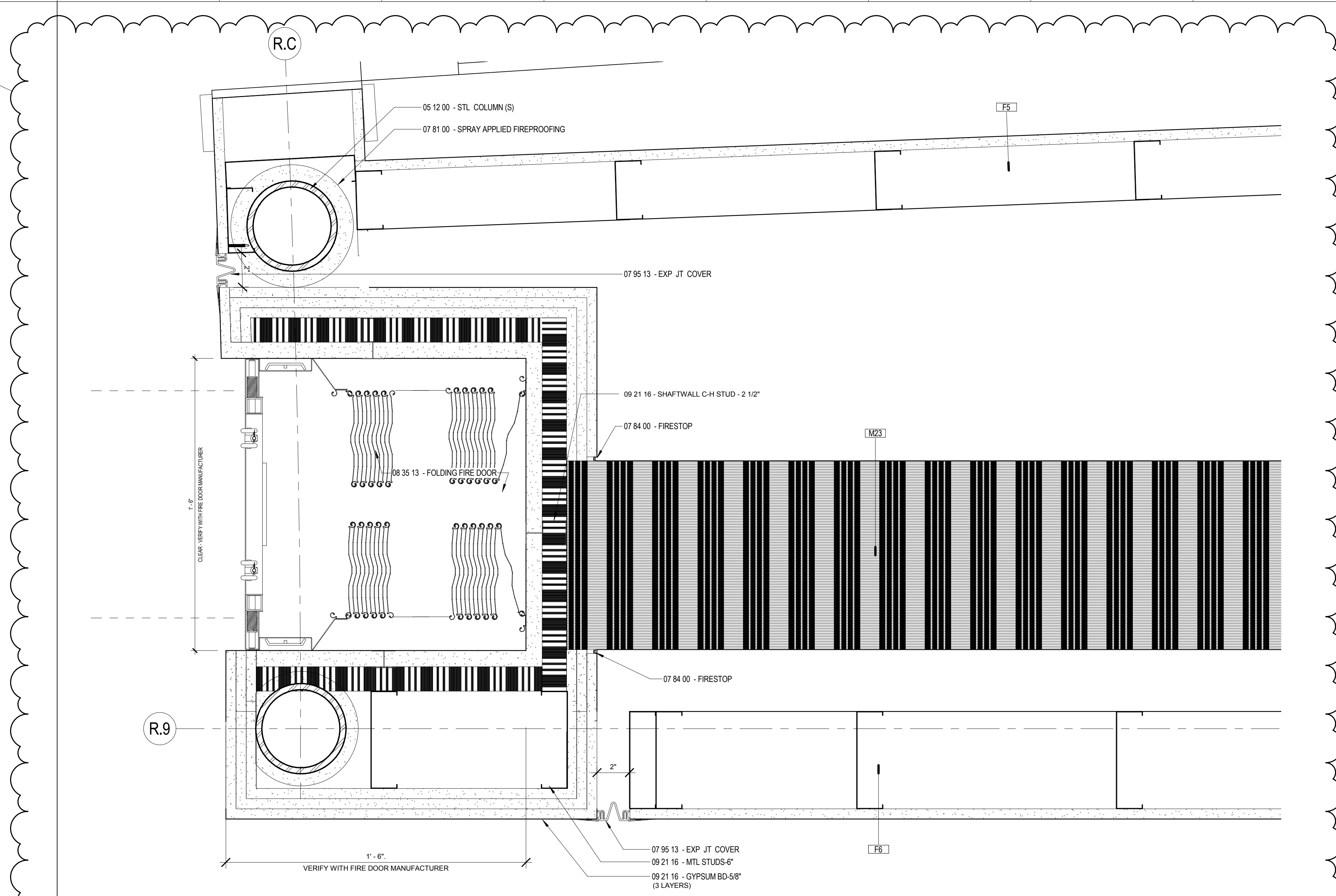

E6 PLAN DETAIL @ WON DOOR POCKET
 A5.8 3" = 1'-0"

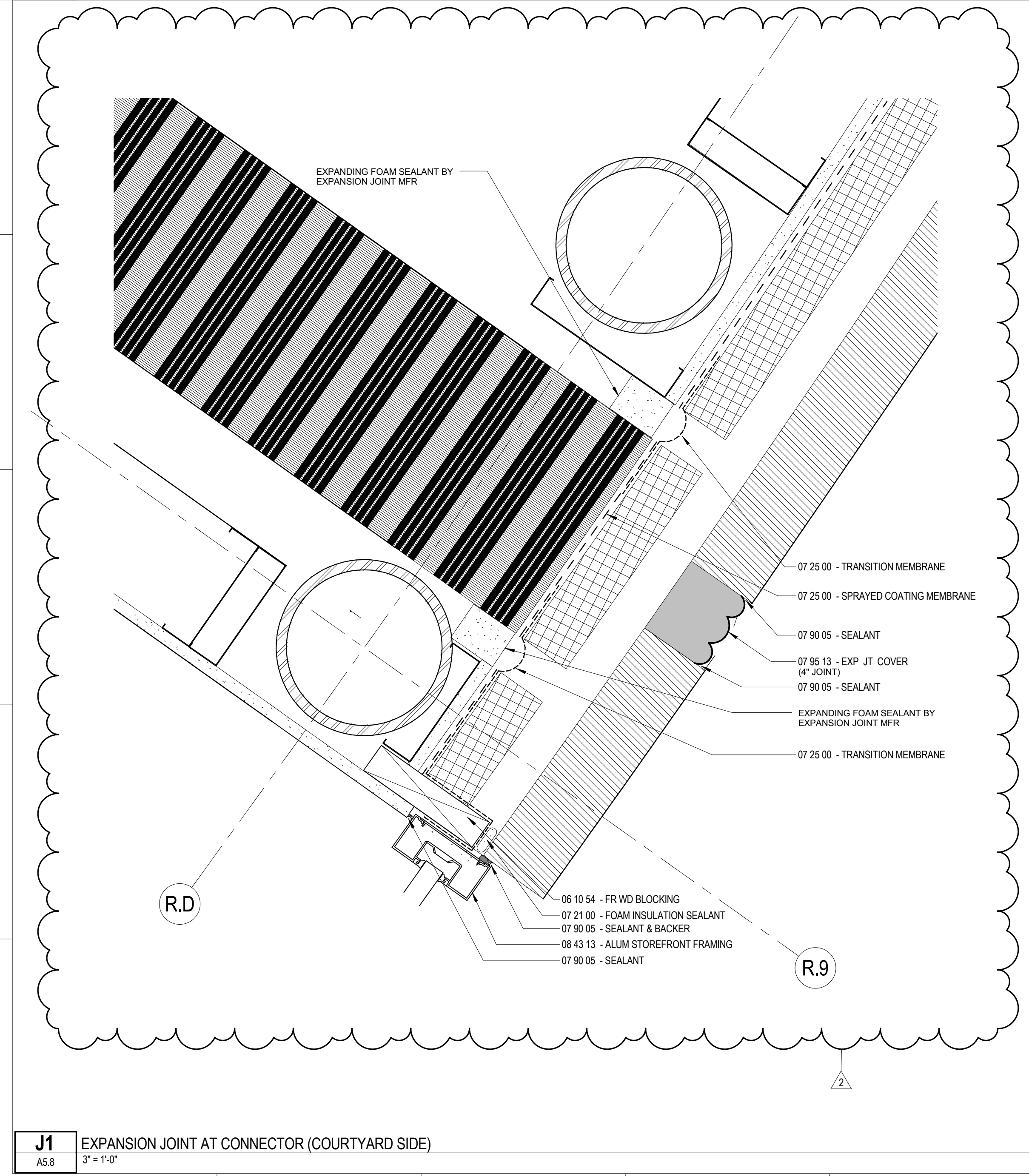

J1 EXPANSION JOINT AT CONNECTOR (COURTYARD SIDE)
 A5.8 3" = 1'-0"

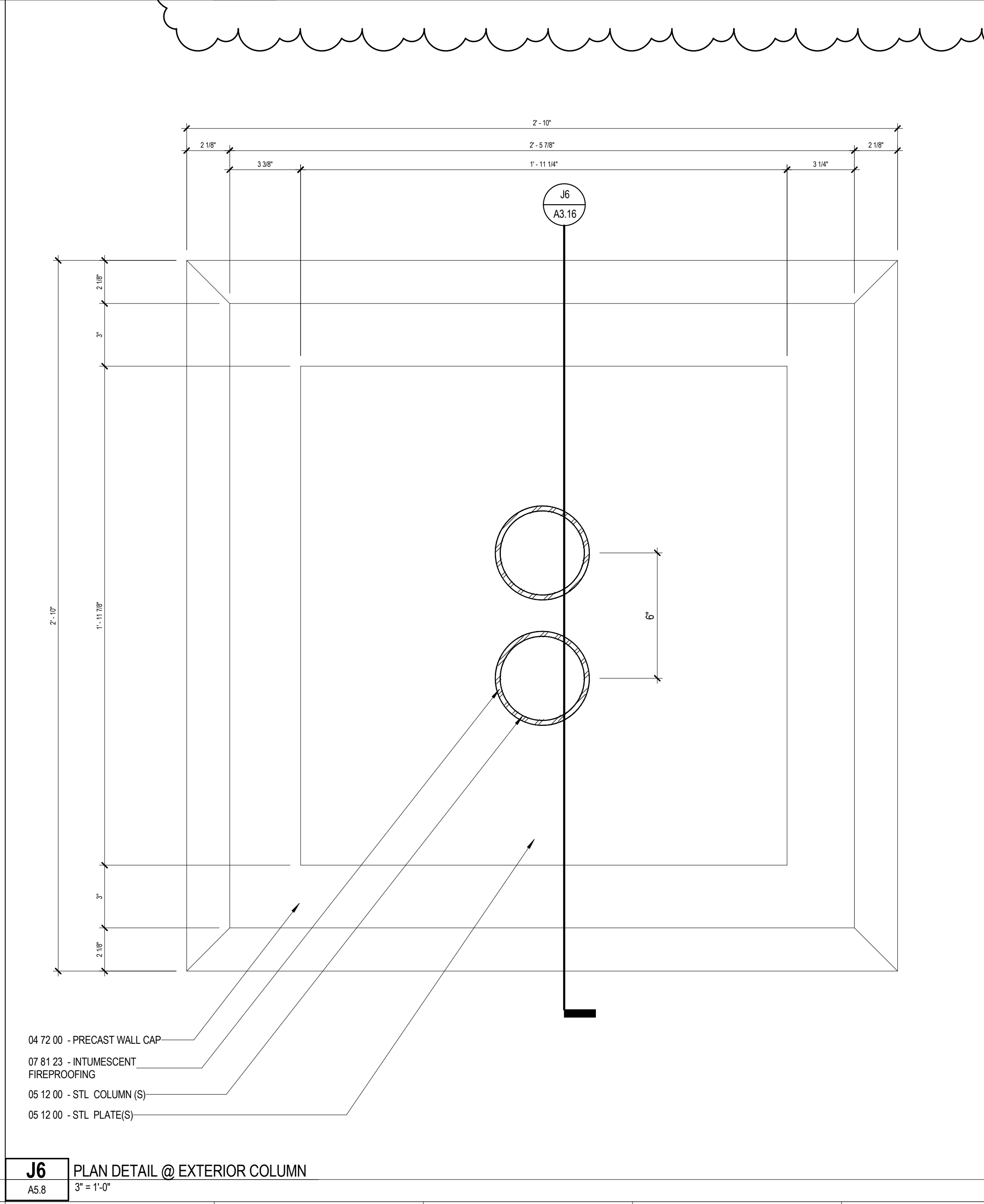

J6 PLAN DETAIL @ EXTERIOR COLUMN
 A5.8 3" = 1'-0"

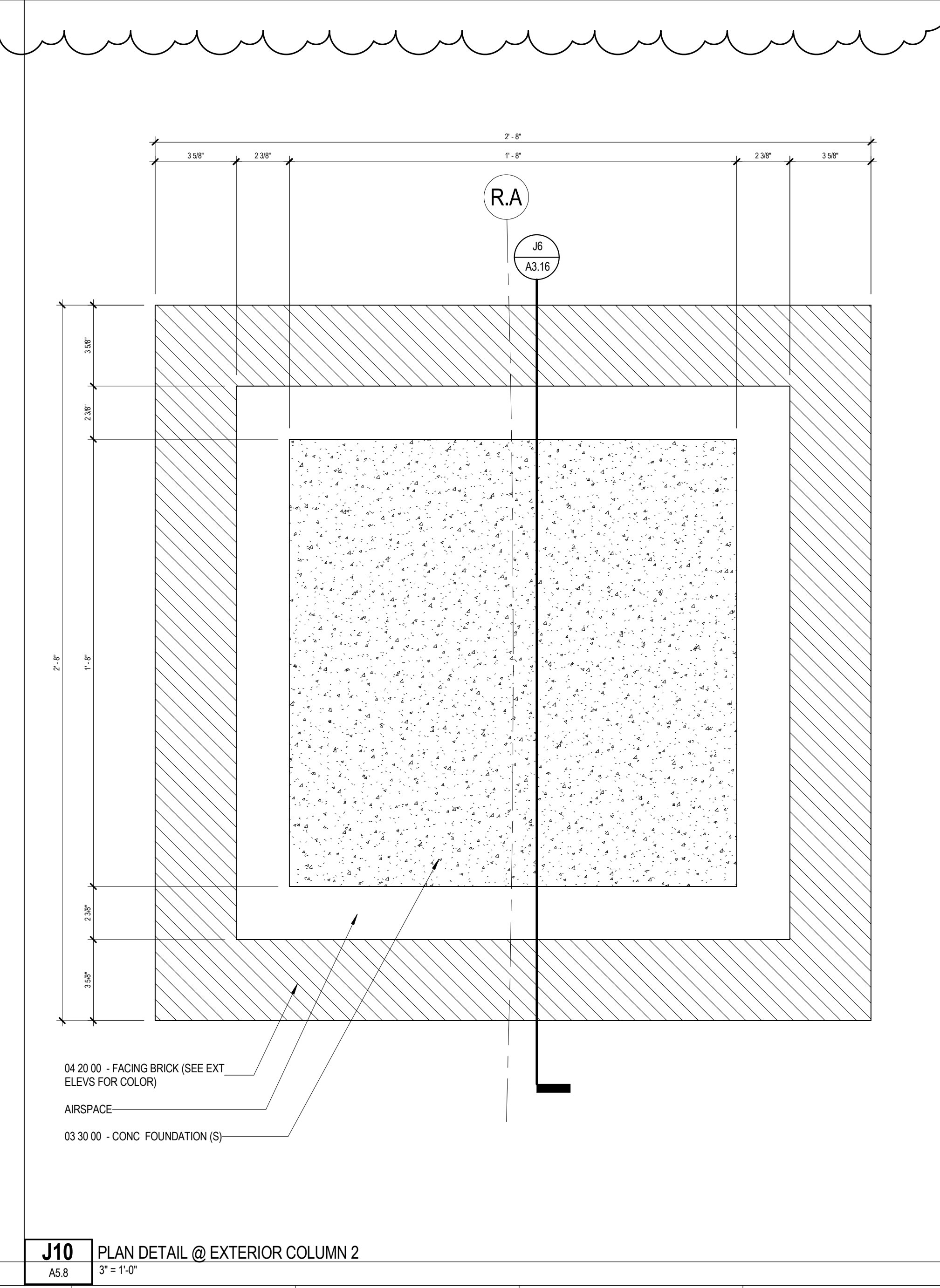

J10 PLAN DETAIL @ EXTERIOR COLUMN 2
 A5.8 3" = 1'-0"