

A  
B  
C  
D  
E  
F  
G  
H  
I  
J

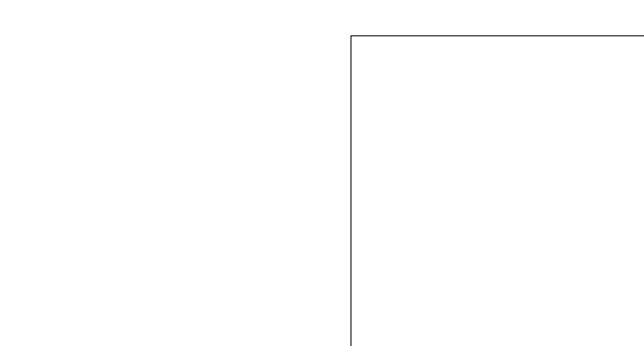

The Park Danforth

**RENOVATIONS AND ADDITIONS**

777 Stevens Ave  
 Portland, ME 04103

NO.	DESCRIPTION	DATE



CONTENT: STAIR DETAILS	
DRAWN BY:	KM
PROJECT NO:	13-059-00
DATE:	06/05/2015
REVISED:	
SCALE:	1/12" = 1'-0"
<b>A4.9</b>	
Project Phase <b>100% CONSTRUCTION DOCUMENTS</b>	
<small>COPYRIGHT © 2015 BY LAVALLEE BRENSINGER PROFESSIONAL ASSOCIATION. ALL RIGHTS RESERVED. NO REPRODUCTION WITHOUT PERMISSION.</small>	

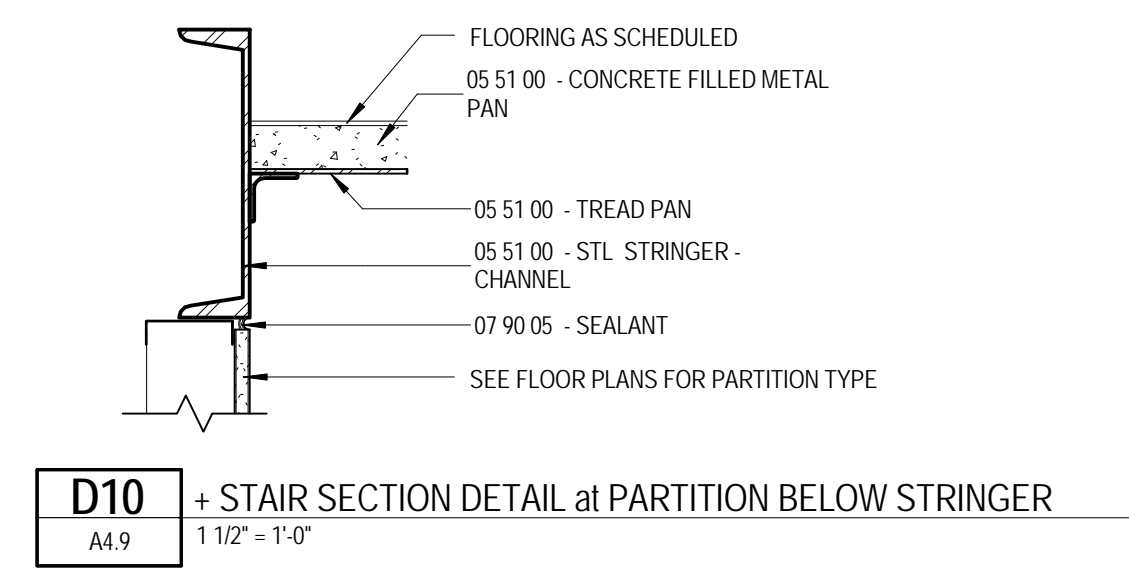

**D10** STAIR SECTION DETAIL at PARTITION BELOW STRINGER  
 A4.9 1/12" = 1'-0"

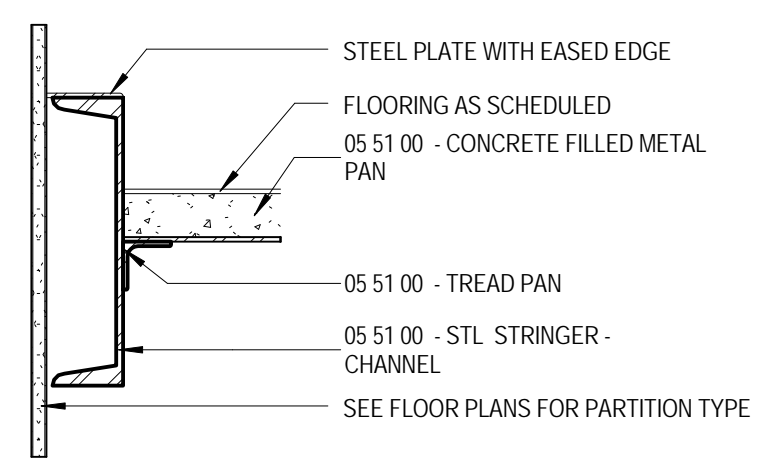

**D7** STAIR SECTION DETAIL at PARTITION ALONG STRINGER  
 A4.9 1/12" = 1'-0"

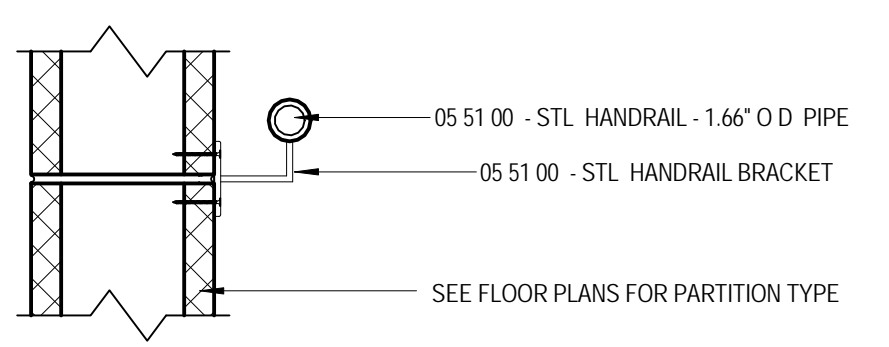

**D4** STAIR SECTION DETAIL AT HANDRAIL  
 A4.9 1/12" = 1'-0"

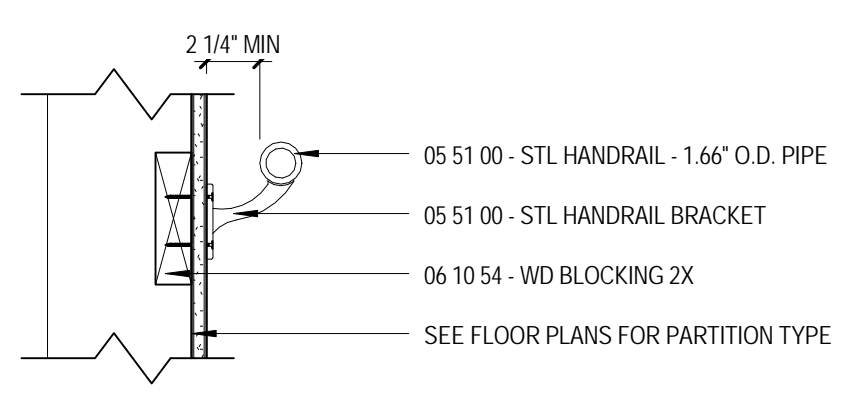

**D1** SECTION DETAIL at HANDRAIL  
 A4.9 1/12" = 1'-0"

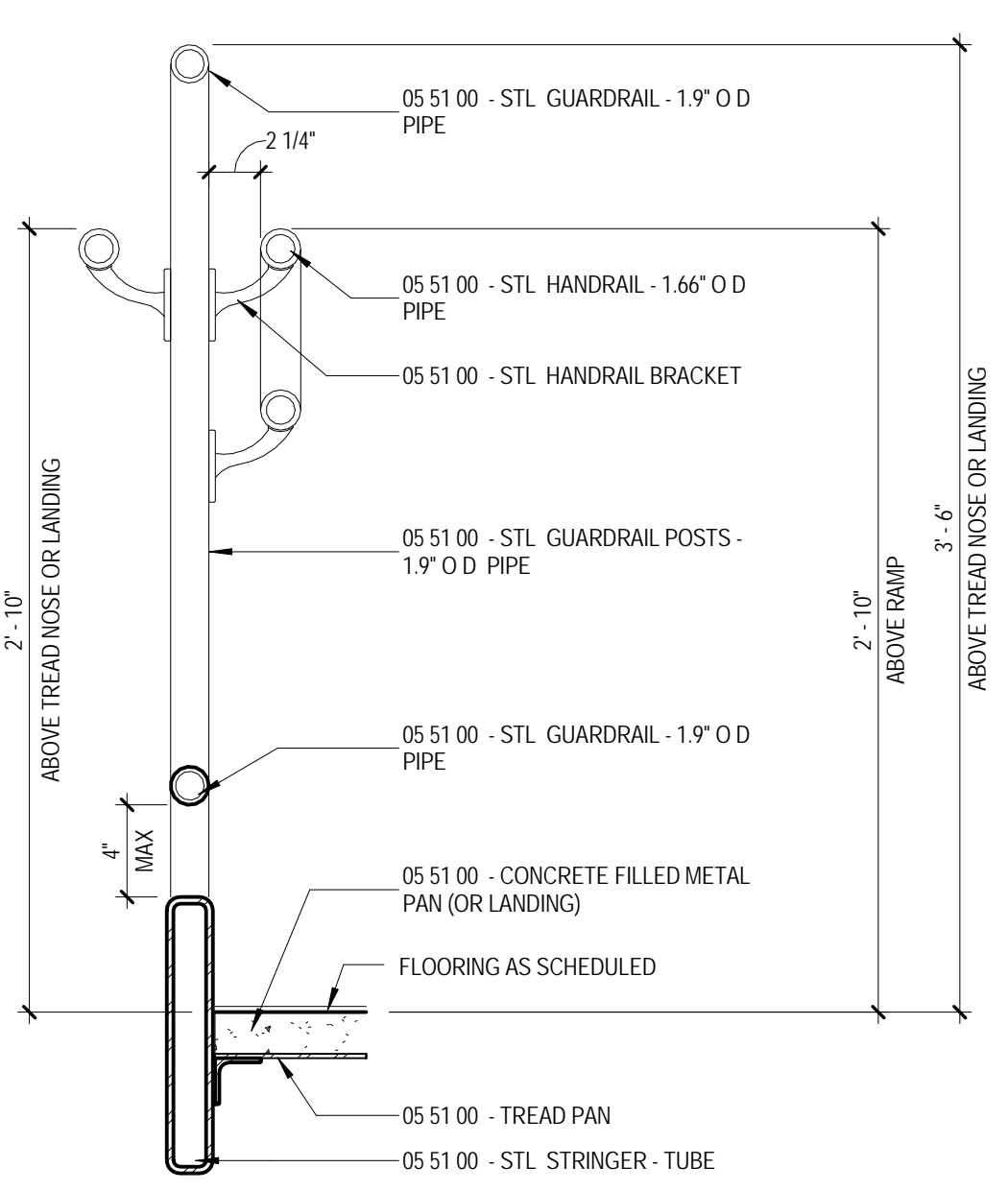

**H10** STAIR DETAIL at GUARDRAIL AND HANDRAIL AT RAMPS  
 A4.9 1/12" = 1'-0"

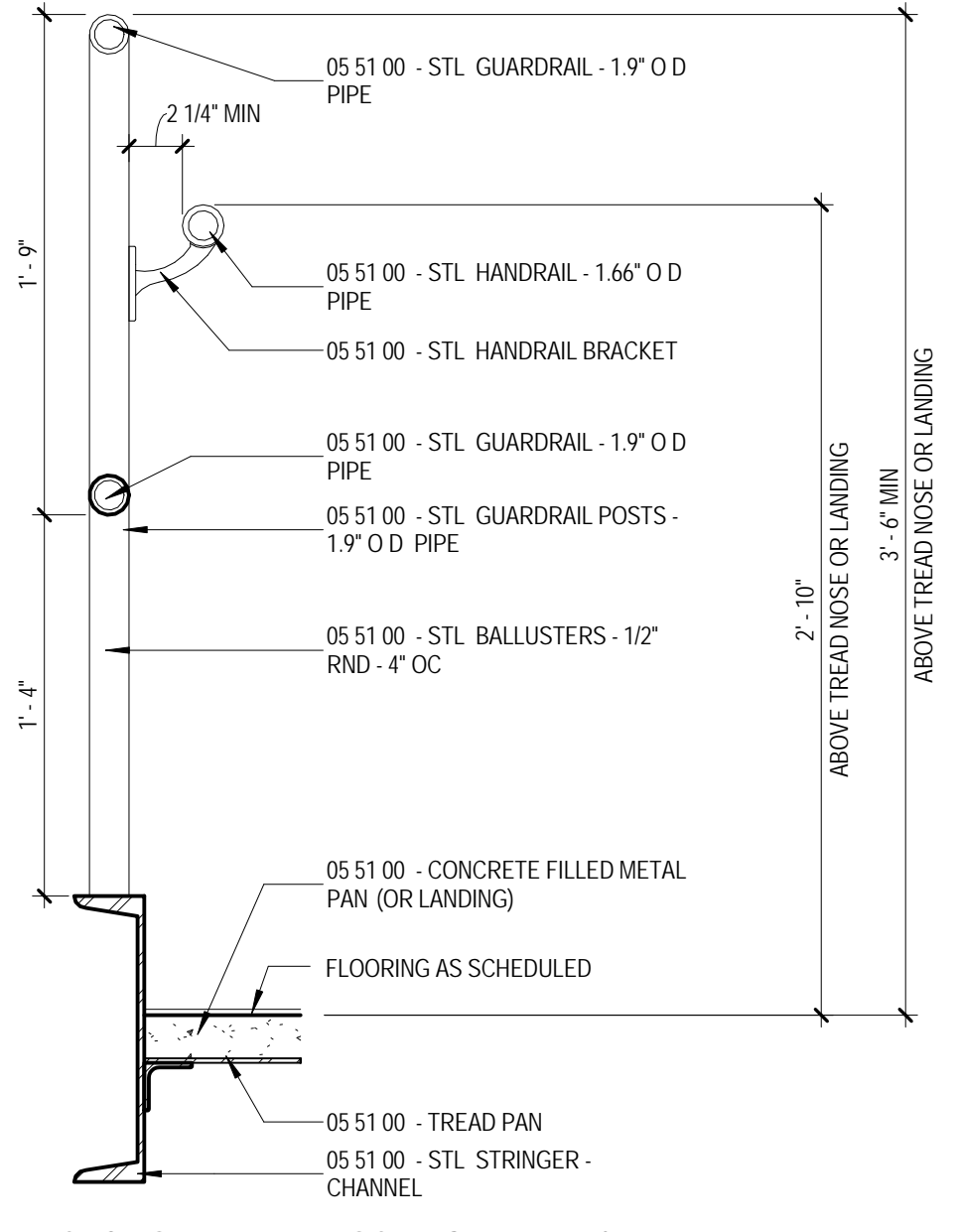

**H7** STAIR SECTION DETAIL at OSHA GUARD and HANDRAIL (CHANNEL STRINGER)  
 A4.9 1/12" = 1'-0"

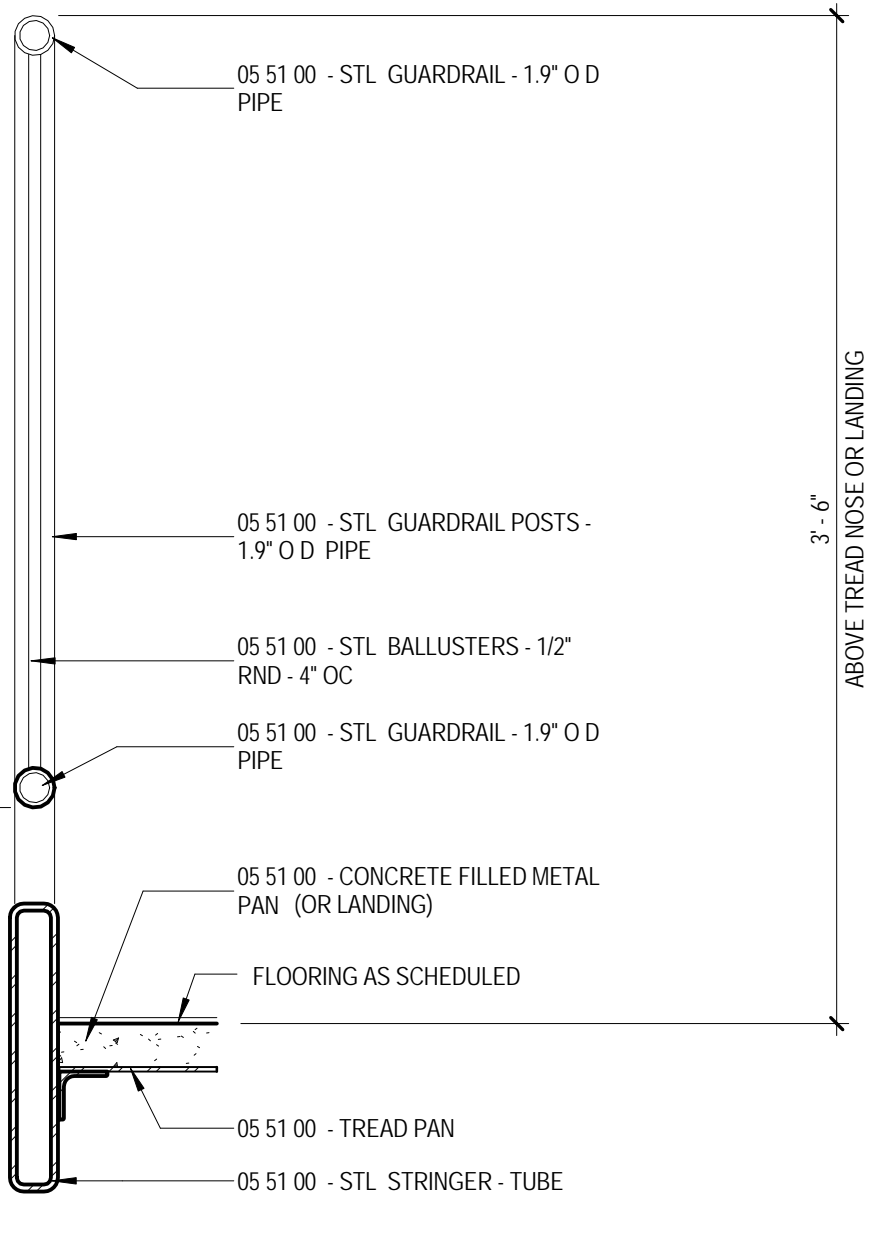

**H4** STAIR DETAIL AT GUARDRAIL  
 A4.9 1/12" = 1'-0"

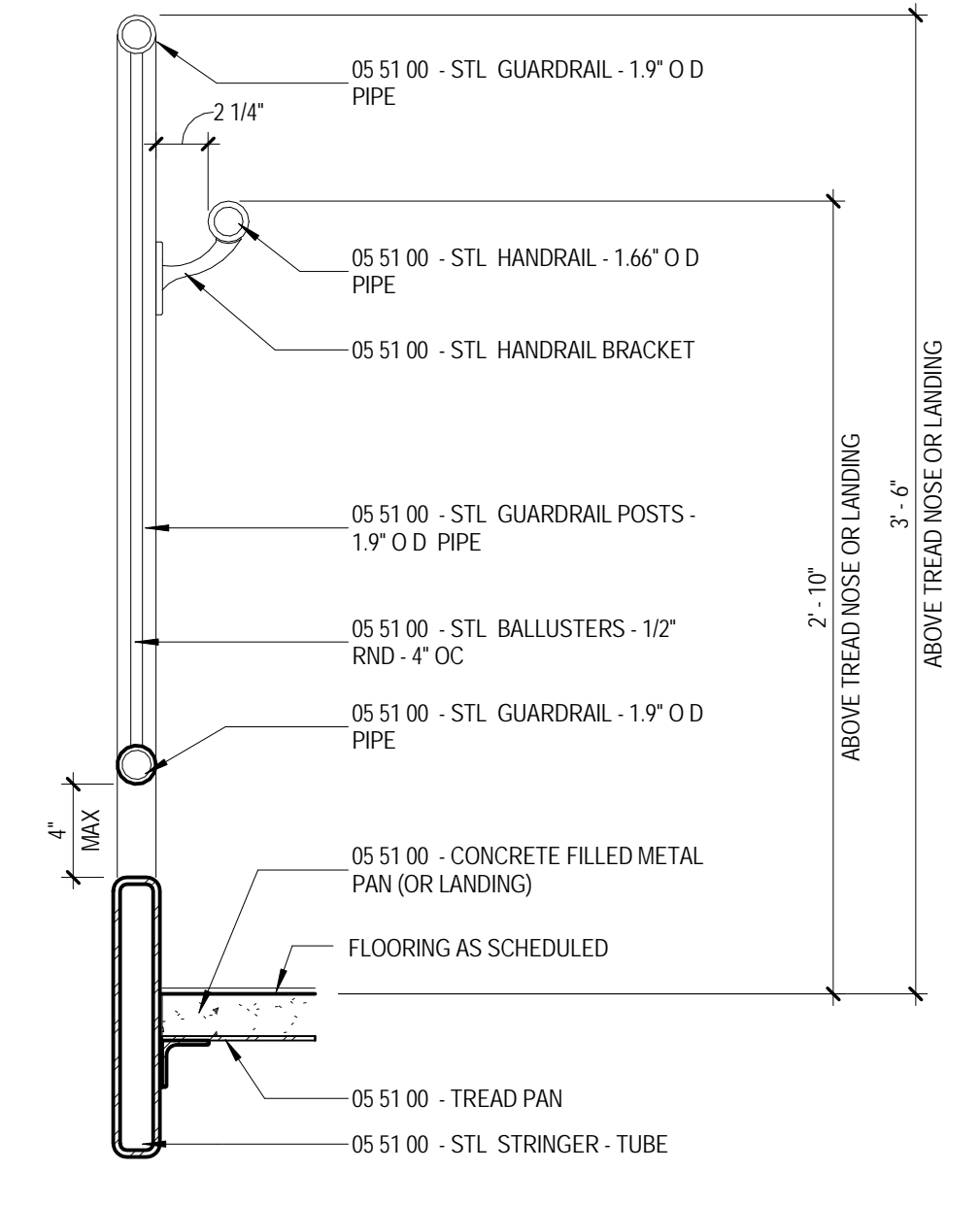

**H1** STAIR DETAIL at GUARDRAIL AND HANDRAIL  
 A4.9 1/12" = 1'-0"

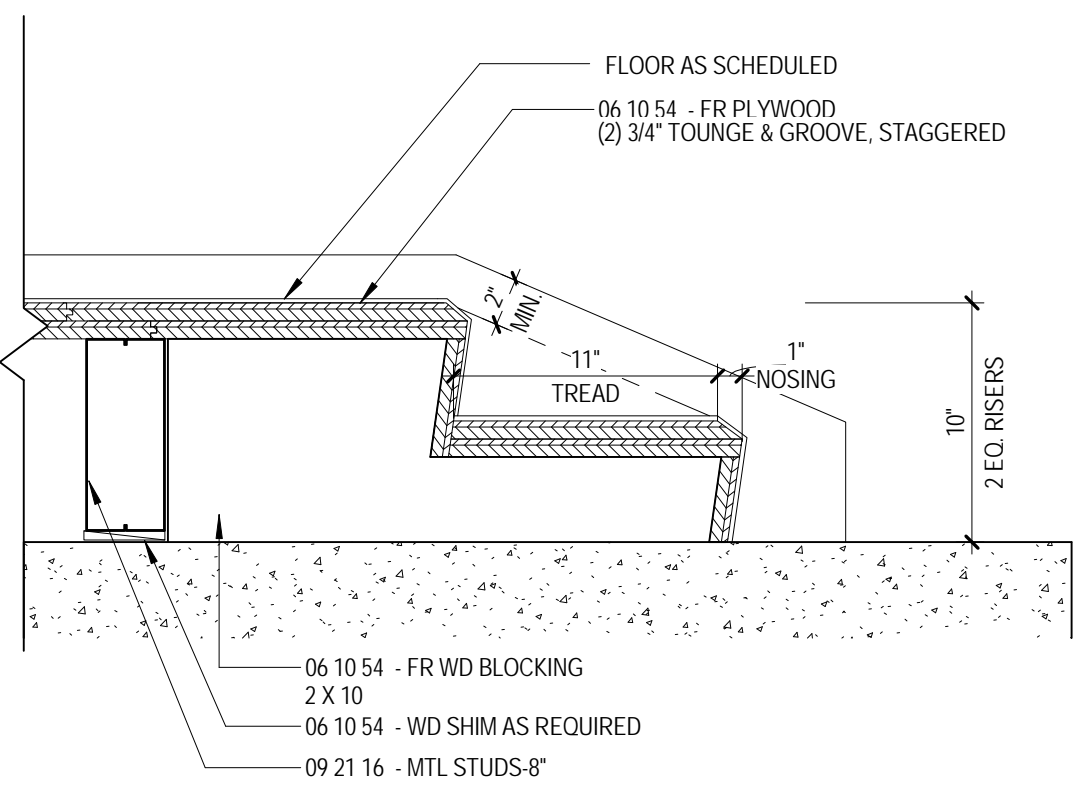

**J10** TYP. STAIR DETAIL at BOTTOM of LIGHTWEIGHT FRAMING STAIR  
 A4.9 1/12" = 1'-0"

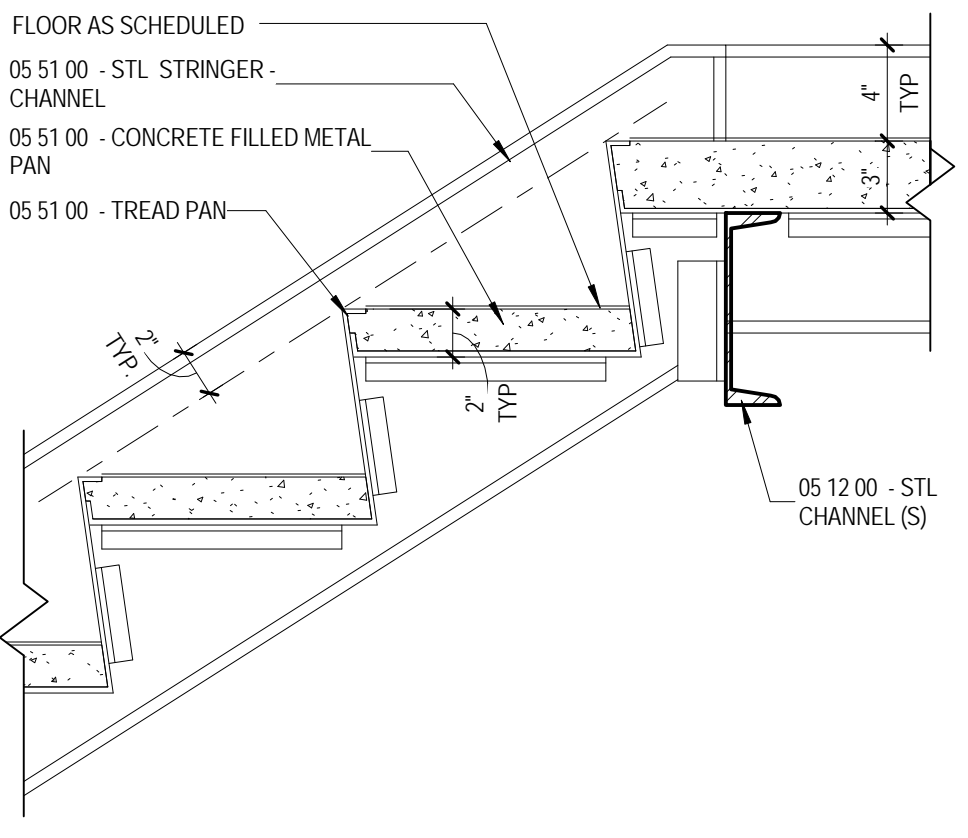

**J7** TYP. STAIR DETAIL AT TOP OF STAIR LANDING  
 A4.9 1/12" = 1'-0"

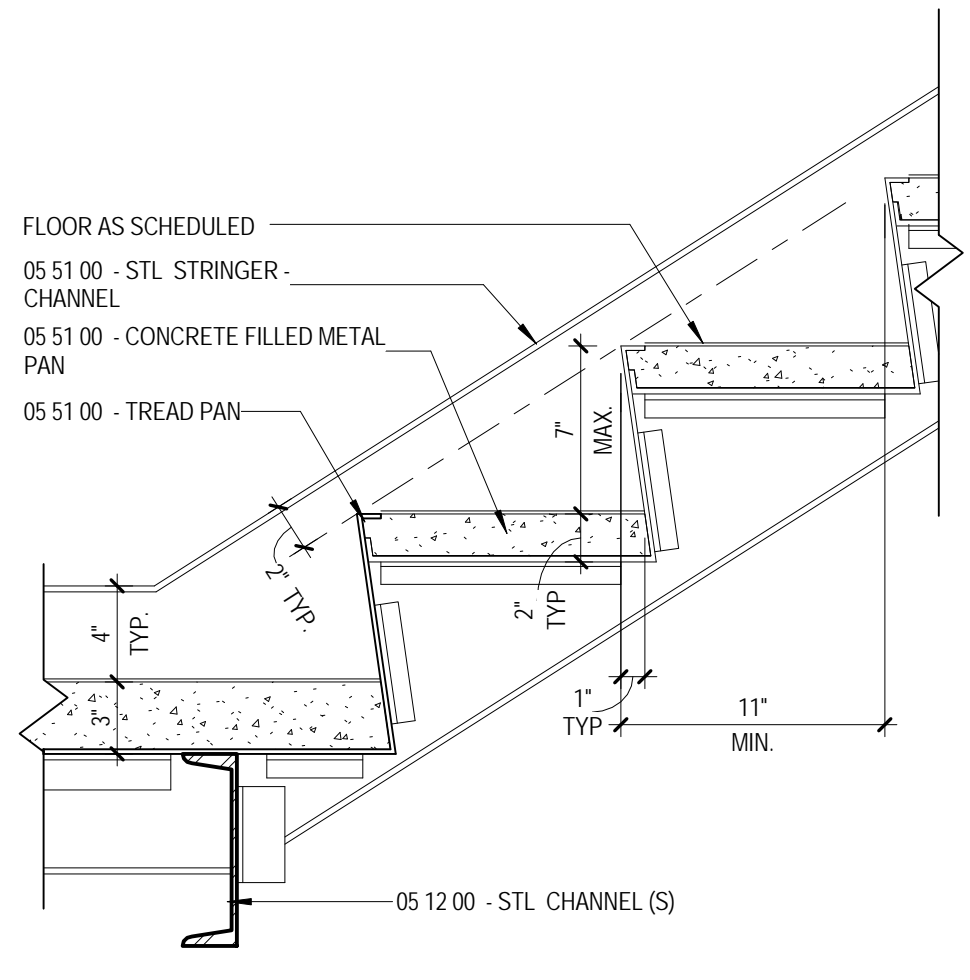

**J4** TYP. STAIR DETAIL AT BOTTOM OF STAIR LANDING  
 A4.9 1/12" = 1'-0"

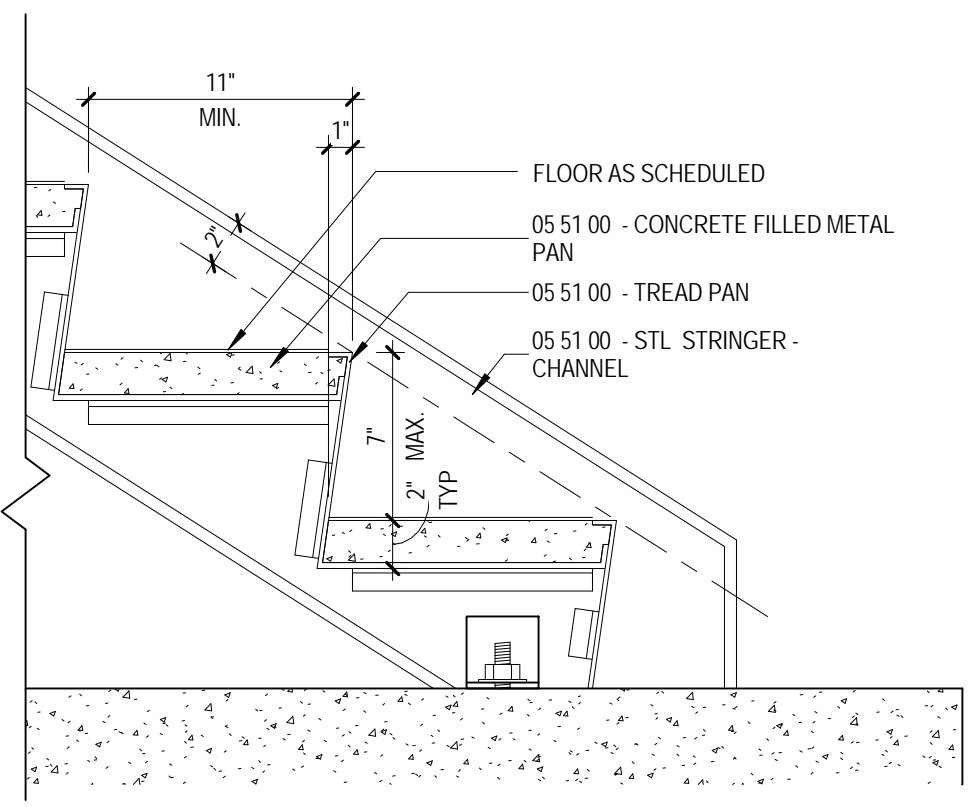

**J1** TYP. STAIR DETAIL at BOTTOM of STAIR  
 A4.9 1/12" = 1'-0"

1 2 3 4 5 6 7 8 9 10 11 12 13 14