

# Garage and Porch Repairs 741 Stevens Ave, Portland ME

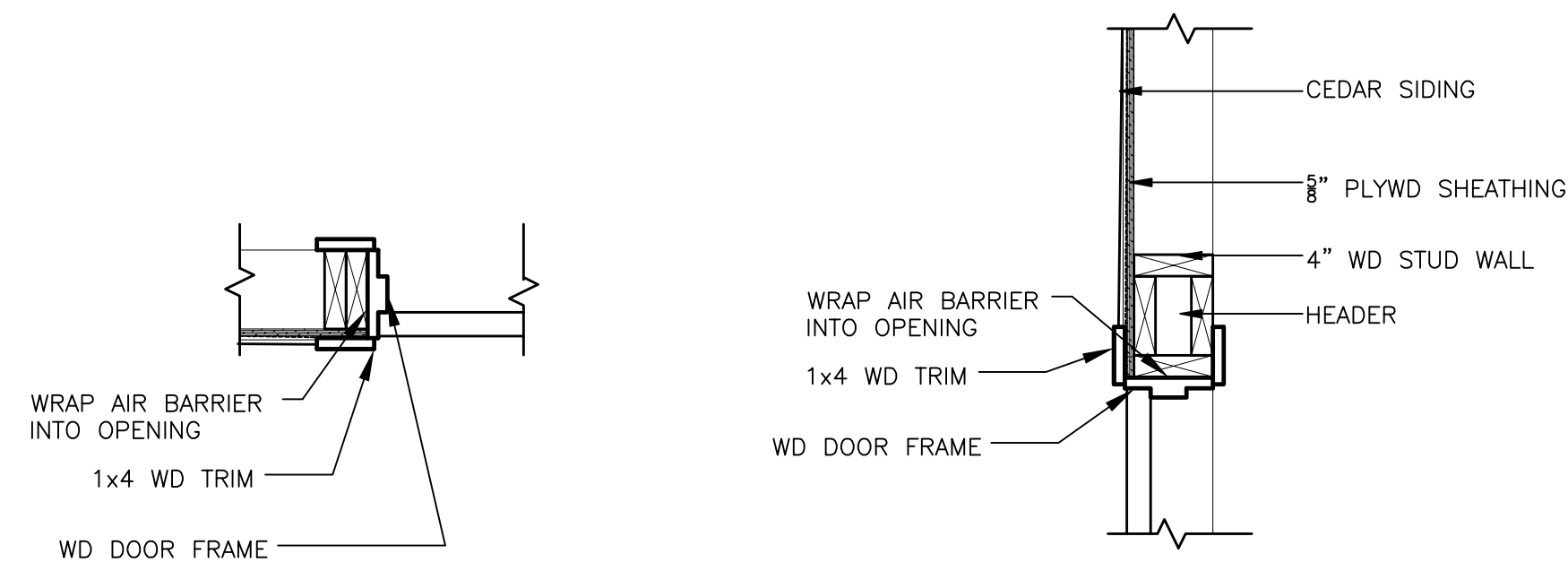

**8 DOOR FRAME DETAILS**  
1/4" = 1'-0"

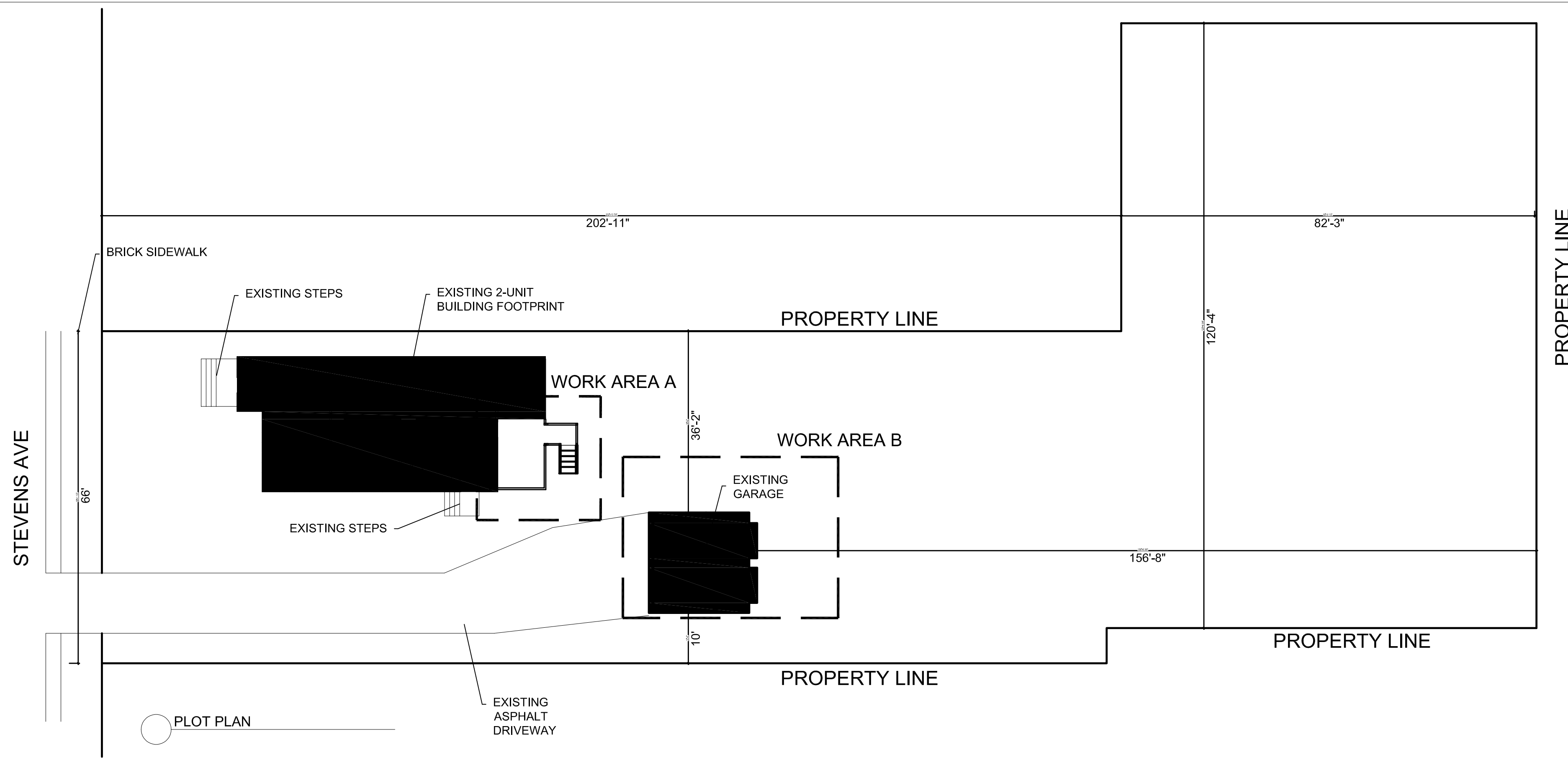

**7 REAR ELEVATION GARAGE - PROPOSED**  
1/4" = 1'-0"



**6 REAR ELEVATION GARAGE - EXISTING**  
1/4" = 1'-0"

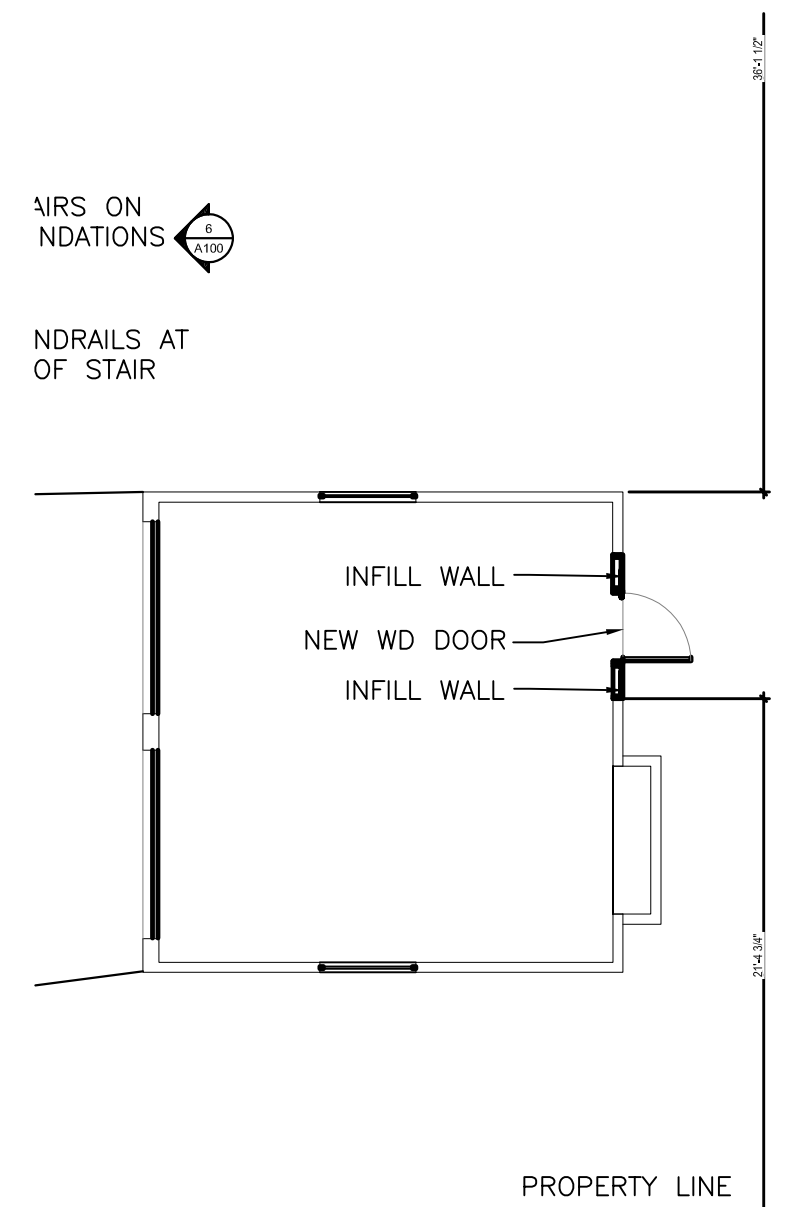

**5 NEW WORK PLAN - GARAGE (WORK AREA B)**  
1/8" = 1'-0"

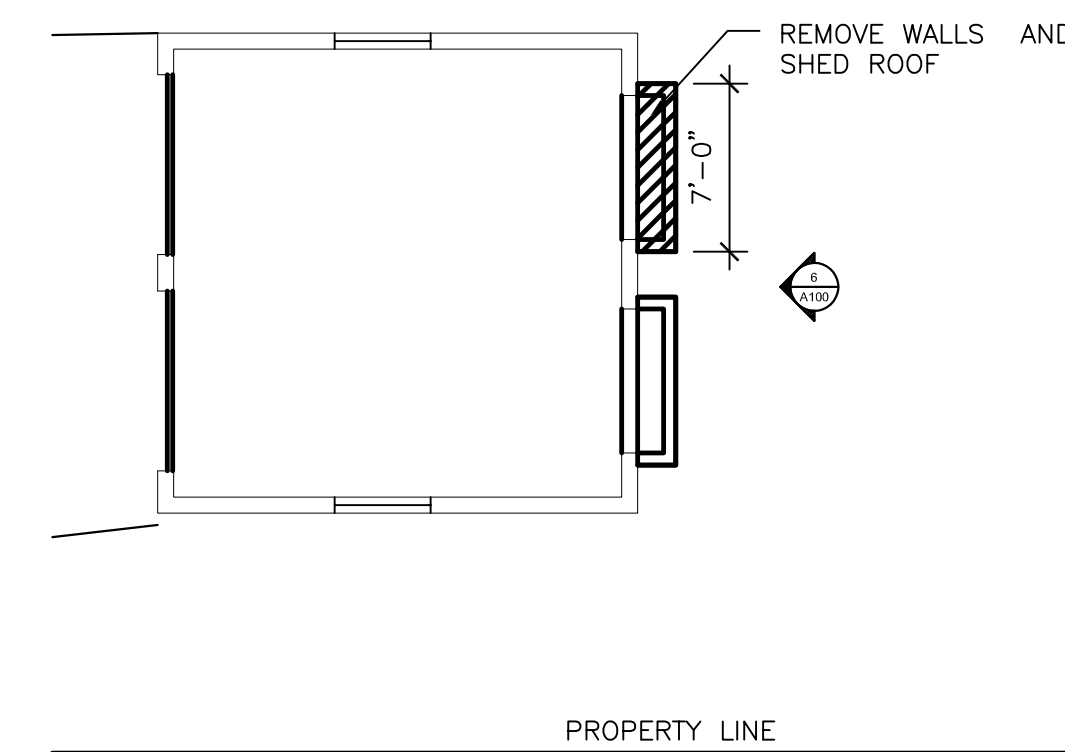

**4 DEMO PLAN - GARAGE (WORK AREA B)**  
1/8" = 1'-0"

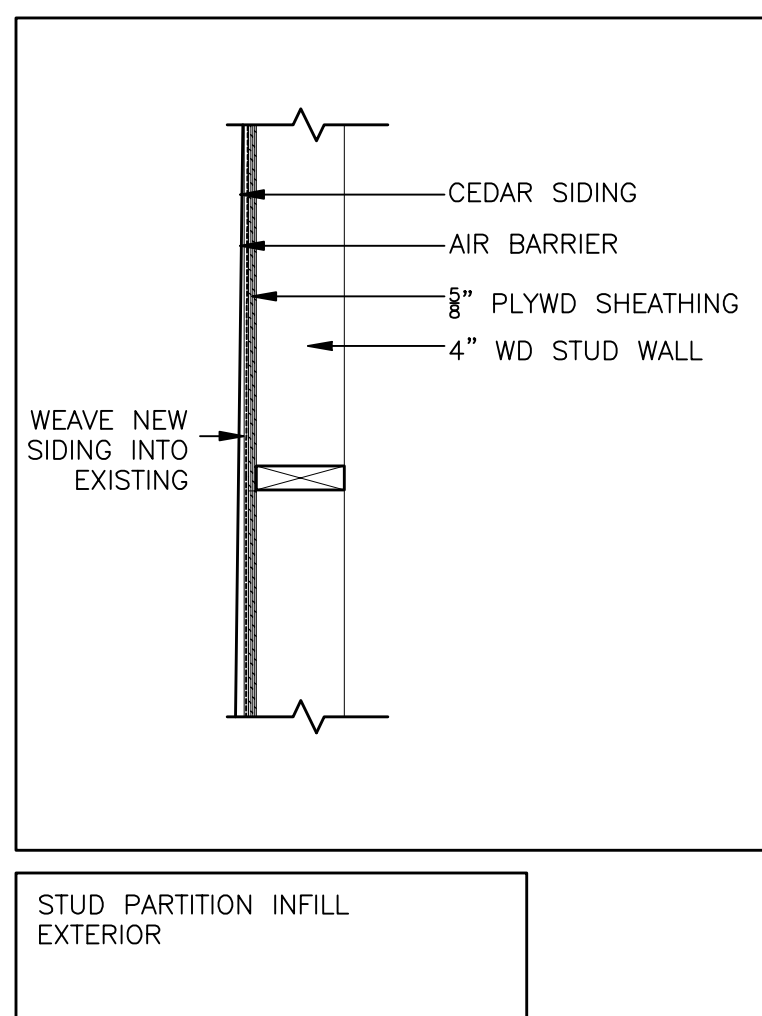

STUD PARTITION INFILL EXTERIOR

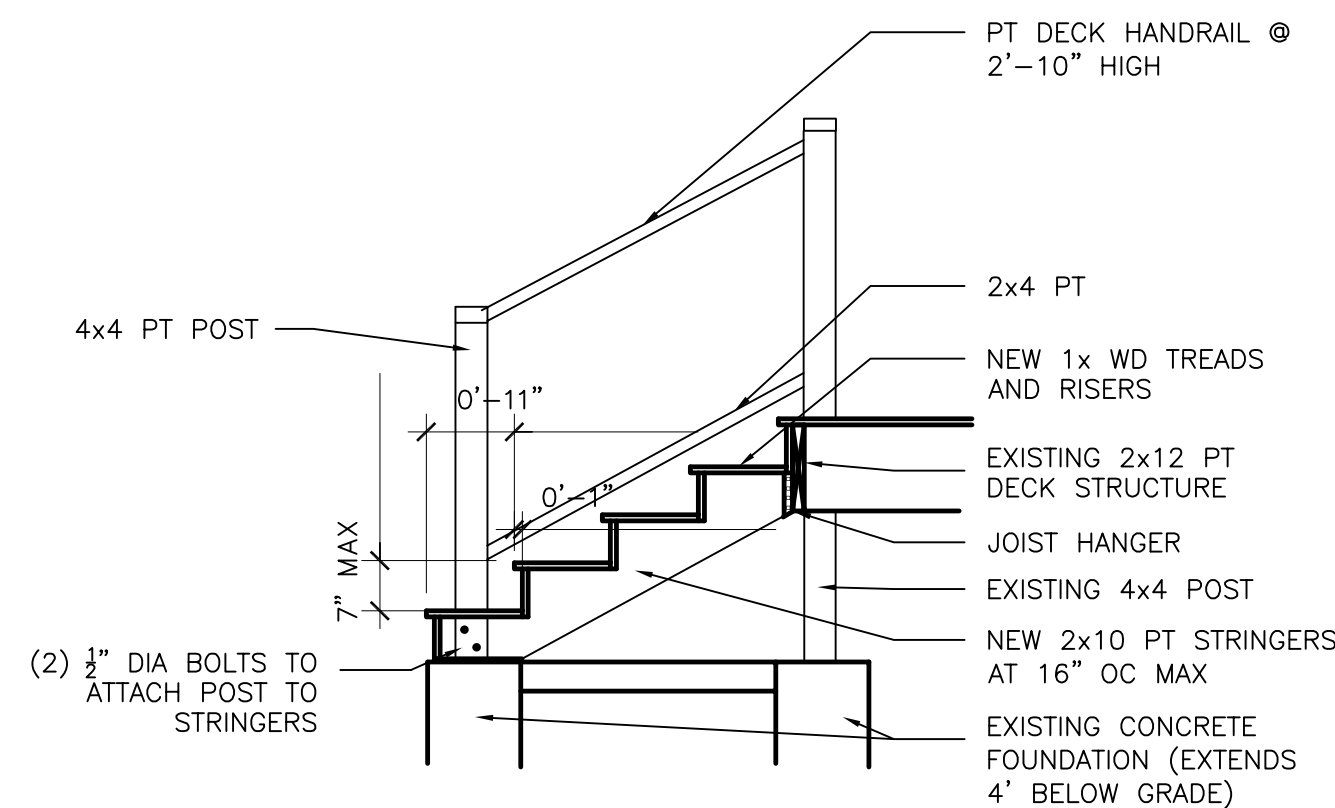

**3 PORCH STAIR DETAIL**  
1/2" = 1'-0"

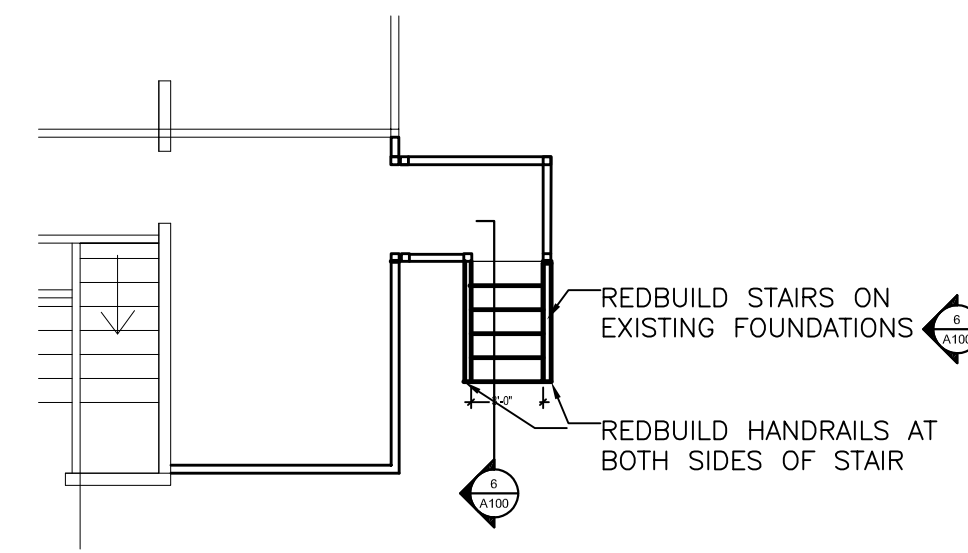

**2 NEW WORK PLAN - PORCH (WORK AREA A)**  
1/8" = 1'-0"

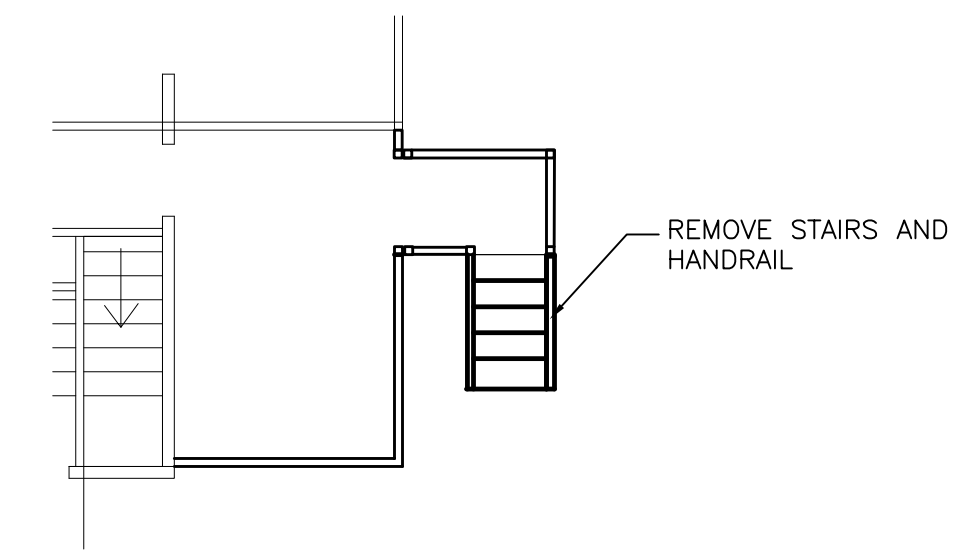

**1 DEMO PLAN - PORCH (WORK AREA A)**  
1/8" = 1'-0"

ISSUE  
5/5/2017

SHEET  
**A100**