



**EST Fire Alarm System
University of New England
Patient Care Center
Portland, Maine**

Revision 1

[Click Here to View
Bill of Material/Index](#)

Prepared For:
Favreau Electric
37 Jordan Avenue
Brunswick, ME 04011
ATTN: Tobie Kay

Prepared By:
Tim Biron
R.B. ALLEN COMPANY, INC.
131 LAFAYETTE ROAD
NORTH HAMPTON, NH 03862



Reviewed By:
Tom DuBois
R.B. ALLEN COMPANY, INC.
131 LAFAYETTE ROAD
NORTH HAMPTON, NH 03862

**EST-EDWARDS SYSTEMS TECHNOLOGY
FIRE ALARM SYSTEM
UNE - Patient Care Center
Portland, Maine
Revision 1 (Changes shown **BOLD**)**

Click on a Description to View Data Sheet

<u>ITEM #</u>	<u>QTY.</u>	<u>CAT#</u>	<u>DESCRIPTION</u>	<u>DATA SHEET #</u>
<u>1</u>				
<u>Fire Alarm Control Panel</u>				
	1	iO500RD	FIRE ALARM CONTROL PANEL Includes: Surface Mount Enclosure Red Door Main Power Supply Addressable Loop (2) Notification Appliance Circuits SA-232 Serial Communications Interface DACT Digital Communicator	85005-0131
	2	12V10A	11 AH Batteries	85010-0127
<u>2</u>				
<u>Intiating Devices</u>				
	6	SIGA-278	Addressable Maunal Station - Double Action	85001-0279
	63	SIGA2-PS	Addressable Photoelectric Smoke Detector	85001-0619
	63	SIGA-SB	Detector Base	85001-0619
	17	SIGA-LED	Remote Alarm Indicator	85001-0619
	2	SIGA2-HFS	Addressable Photoelectric Smoke Detector	85001-0620
	2	SIGA-SB	Detector Base	85001-0620
	2	SIGA-LED	Remote Alarm Indicator	85001-0620
	8	SIGA-SD	Addressable Photoelectric Duct Smoke Detector	85001-0584
	8	SD-T(xx)	Sampling Tube (xx = Size to match Duct width)	85001-0584
	8	SD-TRK	Remote Indicating and Key Test Station	85001-0584
	17	SIGA-CT1	Addressable Monitor Module (Sprinkler)	85001-0241
	1	SIGA-CT1	Addressable Monitor Module (Radio Box)	85001-0241
	4	SIGA-CT1	Addressable Monitor Module (BDA)	85001-0241
	2	SIGA-CT1	Addressable Monitor Module (Elev Shunt Trip Power)	85001-0241
	1	SIGA-CC1	Addressable Signal Module (Sprinkler Beacon)	85001-0237
	20	SIGA-CR	Addressable Control Relay	85001-0239
<u>3</u>				
<u>Indicating / Miscellaneous Devices</u>				
	65	G1RF-HDVM	Horn/Strobe Unit (Adjustable Candela - Wall Mount Red)	85001-0573
	14	G1RF-VM	Strobe Unit (Adjustable Candela - Wall Mount Red)	85001-0573
	4	BPS6A	Auxiliary Power Supply	85005-0125
	8	12V6A5	7.2 AH Batteries	85010-0127
	1	495S1280W	Exterior Strobe Beacon	TOMAR
	1	AES	Subscriber Radio Box Unit w/ Portland Accessories	AES
	2	1505-AQN5	Magnetic Door Holder - Flush Mount	85001-0421
	5	PR-1	Intermediate Relay	#1782

EST-EDWARDS SYSTEMS TECHNOLOGY
FIRE ALARM SYSTEM
UNE - Patient Care Center
Portland, Maine

4

Supporting Documentation

Click on a Document to View Content

System Descriptive Narrative

System Sequence of Operation Matrix

System Warranty

Fire Alarm Control Panel Battery Calculations

Auxiliary Power Supply Battery Calculations

Appliance Circuit Voltage Drop/Max Length Calculations

Fire Alarm Permit

Master Box Permit

AES Radio Subscriber Unit Setup

Fire Alarm System Riser Diagram

**EST3 Addressable Fire Alarm System
UNE Patient Care Center
Portland, Maine**

[Click Here to Return to Bill of Material/Index](#)

BATTERY STANDBY CALCULATIONS - Fire Alarm Control Panel

QTY	Model #	Description	Quiescent Current	Alarm Current	Total Quiescent	Total Alarm
1	iO500RD	Base Panel	0.172000	0.267000	0.172000	0.267000 Amp
1	SA-DACT	Digital Communicator	0.041000	0.041000	0.041000	0.041000 Amp
1	SA-232	Serial Communications Card	0.013000	0.020000	0.013000	0.020000 Amp
6	SIGA-278	Addressable Manual Pull Station	0.000250	0.000400	0.001500	0.002400 Amp
63	SIGA-PS	Addressable Smoke Detector	0.000045	0.000045	0.002835	0.002835 Amp
8	SIGA-SD	Addressable Duct Smoke Detector	0.000045	0.018000	0.000360	0.144000 Amp
22	SIGA-CT1	Addressable Singal Input Module	0.000250	0.000400	0.005500	0.008800 Amp
20	SIGA-CR	Addressable Control Module	0.000100	0.000100	0.002000	0.002000 Amp
1	SIGA-CC1	Addressable Signal Module	0.000223	0.000100	0.000223	0.000100 Amp
1	495S1280W	Exterior Beacon	0.000000	0.035000	0.000000	0.035000 Amp
Total					0.238418	0.523135 Amp

Total Quiescent x Time Required (24 Hours): **5.722032** Ah
 Total Alarm x Time Required (15 Minutes): **0.1307838** Ah
Total Battery Required: 5.8528158 Ah
Total Battery Required (+) 20% Spare Capacity: 7.0233789 Ah

Battery Supplied: 11 Ah

UNE Patient Care Center

Booster Power Supply Standby Battery Calculations Revision 1

[Click Here to Return to Bill of Material/Index](#)

Strobe Booster Panel - Basemnet/1st Floor (BPS6A-1)

	G1RF-HDVM Horn/Strobe (20v)				G1RF-VM (20v)				Quiescent Current	Alarm Current
	15cd	30cd	75cd	110cd	15cd	30cd	75cd	110cd		
	88	109	193	248	71	98	188	240		
Panel									0.0700	
Circuit 1			8							1.5440
Circuit 2			11							2.1230
n/a										0.0000
n/a										0.0000
									0.0700	3.6670
									Total Quiescent	Total Alarm

All currents are expressed as mA.
 Max current per ckt = 2.5 Amps. Max current per panel = 6.0 Amps.

Remaining % of Ckt Capacity	Remaining % Panel
38.24 %	
15.08 %	
100.00 %	
100.00 %	
38.88 %	Remaining % Panel

Total Quiescent Amp x Time Required (24 Hours) 1.680 AmpHr
 Total Alarm Amp x Time Required (15 Minutes) 0.917 AmpHr
 Total Battery Required 2.597 AmpHr
 Total Battery Required + 20% Battery Supplied **3.116 AmpHr**
7.2 AmpHr

Strobe Booster Panel - 1st Floor (BPS6A-2)

	G1RF-HDVM Horn/Strobe (20v)				G1RF-VM (20v)				Quiescent Current	Alarm Current
	15cd	30cd	75cd	110cd	15cd	30cd	75cd	110cd		
	88	109	193	248	71	98	188	240		
Panel									0.0700	
Circuit 1			10		2					2.0720
Circuit 2			11		4					2.4070
n/a										0.0000
n/a										0.0000
									0.0700	4.4790
									Total Quiescent	Total Alarm

All currents are expressed as mA.
 Max current per ckt = 2.5 Amps. Max current per panel = 6.0 Amps.

Remaining % of Ckt Capacity	Remaining % Panel
17.12 %	
3.72 %	
100.00 %	
100.00 %	
25.35 %	Remaining % Panel

Total Quiescent Amp x Time Required (24 Hours) 1.680 AmpHr
 Total Alarm Amp x Time Required (15 Minutes) 1.120 AmpHr
 Total Battery Required 2.800 AmpHr
 Total Battery Required + 20% Battery Supplied **3.360 AmpHr**
7.2 AmpHr

UNE Patient Care Center

Booster Power Supply Standby Battery Calculations Revision 1

[Click Here to Return to Bill of Material/Index](#)

Strobe Booster Panel - 2nd Floor (BPS6A-3)

	G1RF-HDVM Horn/Strobe (20v)				G1RF-VM (20v)				Quiescent Current	Alarm Current
	15cd	30cd	75cd	110cd	15cd	30cd	75cd	110cd		
	88	109	193	248	71	98	188	240		
Panel									0.0700	
Circuit 1			10		1					2.0010
n/a										0.0000
n/a										0.0000
n/a										0.0000
									0.0700	2.0010
									Total Quiescent	Total Alarm

All currents are expressed as mA.
 Max current per ckt = 2.5 Amps. Max current per panel = 6.0 Amps.

Remaining % of Ckt Capacity	
19.96 %	
100.00 %	
100.00 %	
100.00 %	
66.65 %	Remaining % Panel

Total Quiescent Amp x Time Required (24 Hours) 1.680 AmpHr
 Total Alarm Amp x Time Required (15 Minutes) 0.500 AmpHr
 Total Battery Required 2.180 AmpHr
 Total Battery Required + 20% Battery Supplied **2.616** AmpHr
7.2 AmpHr

Strobe Booster Panel - 2nd Floor (BPS6A-4)

	G1RF-HDVM Horn/Strobe (20v)				G1RF-VM (20v)				Quiescent Current	Alarm Current
	15cd	30cd	75cd	110cd	15cd	30cd	75cd	110cd		
	88	109	193	248	71	98	188	240		
Panel									0.0700	
Circuit 1			6		7					1.6550
Circuit 2			9							1.7370
n/a										0.0000
n/a										0.0000
									0.0700	3.3920
									Total Quiescent	Total Alarm

All currents are expressed as mA.
 Max current per ckt = 2.5 Amps. Max current per panel = 6.0 Amps.

Remaining % of Ckt Capacity	
33.80 %	
30.52 %	
100.00 %	
100.00 %	
43.47 %	Remaining % Panel

Total Quiescent Amp x Time Required (24 Hours) 1.680 AmpHr
 Total Alarm Amp x Time Required (15 Minutes) 0.848 AmpHr
 Total Battery Required 2.528 AmpHr
 Total Battery Required + 20% Battery Supplied **3.034** AmpHr
7.2 AmpHr

**UNE Patient Care Center
Portland, Maine
NAC Circuit Voltage Drop/Maximum Length Calculations**

Revision 1

[Click Here to Return to Bill of Material/Index](#)

Formulas Used:

$$R_t = (D) \times (R_w) / 1000'$$

$$V_d = (R_t) \times (I_t)$$

Substitute for (R_t) and solve for D

$$D = ((4.0) \times (1000)) / ((R_w) \times (I_t))$$

R_t = Total Circuit Resistance

D = Total Circuit Length (Feet)

R_w = Wire Resistance (Ω) per 1000' Pair (Ohms)

V_D = Circuit Voltage Drop (Max allowed is 4.0Vdc)

I_t = Total Circuit Current

Notes:

- 1 NAC Circuit terminal voltage 24Vdc.
- 2 A maximum allowable voltage drop of 4Vdc will provide a minimum of 20 Vdc per circuit.
- 3 Current values listed per device are based on 20Vdc.

HORN/STROBE CIRCUIT MAX WIRE LENGTH CALCULATION

Current (mA)	G1RF-HDVM			G1RF-VM			495S1280	GCF-VMH	Total Circuit Current	Ω per 1000' Pair		Volt Drop
	88	193	248	71	98	188	350	303		12AWG (3.5)	14AWG (5.2)	
Ckt/Cd	15cd	75cd	110cd	15cd	30cd	75cd	n/a	115cd	Amp	Max Length (Ft)	Max Length (Ft)	
BPS6A-1 Ckt1		8							1.5440	740.19	498.21	4.0
BPS6A-1 Ckt2		11							2.1230	538.32	362.33	4.0
BPS6A-2 Ckt1		10		2					2.0720	551.57	371.25	4.0
BPS6A-2 Ckt1		11		4					2.4070	474.81	319.58	4.0
BPS6A-3 Ckt1		10		1					2.0010	571.14	384.42	4.0
BPS6A-3 Ckt2												
BPS6A-4 Ckt1		6		7					1.6550	690.55	464.79	4.0
BPS6A-4 Ckt2		9							1.7370	657.95	442.85	4.0

**EST Addressable Fire Alarm System
UNE Patient Care Center
Portland, Maine**

[Click Here to Return to
Bill of Material/Index](#)

System Narrative

In the event of an alarm from an actuated device, the following shall

occur: (Devices reporting an alarm: Manual Station, Smoke, Duct Smoke, or Waterflow Switch)

- 1) Notify the Fire Department via the Radio Master Box;
 notify Central Station monitoring company via the Digital Communicator (DACT).
- 2) Sound a Code 3 Temporal on all Horn Circuits
- 3) Flash all strobe appliance circuits in a synchronized manner
- 4) Close second floor fire shutters
- 5) Annunciate audibly, visually, and in plain english the active initiating device at the fire alarm control panel
- 6) Waterflow shall, in addition to the above, activate the exterior White Strobe/Beacon

In the event of a supervisory condition from an actuated device, the

following shall occur: (Devices reporting as supervisory: Tamper Switch, Sprinkler Supervisory Switch)

- 1) Notify the Central Station monitoring company via the Digital Communicator (DACT).
- 2) Annunciate audibly, visually, and in plain english the active initiating device at the fire alarm control panel

In the event of a system trouble report, the following shall occur:

- 1) Notify the Central Station monitoring company via the Digital Communicator (DACT).
- 2) Annunciate audibly, visually, and in plain english the active initiating device at the fire command center

SEQUENCE OF OPERATION MATRIX

<i>Alarm Signal to Fire Department via Radio Box</i>	<i>Alarm Signal to Central Station via DACT</i>	<i>Annunciate at Fire Alarm Control Panel</i>	<i>Activate Evacuation Sequence</i>	<i>Activate Exterior Strobe Beacon</i>	<i>Shutdown Associated HVAC Unit</i>	<i>Close Fire Shutters</i>	<i>Supervisory Signal to Central Station via MODCOM</i>	<i>Trouble Signal to Central Station via MODCOM</i>
--	---	---	-------------------------------------	--	--------------------------------------	----------------------------	---	---

System Inputs	A	B	C	D	E	F	G	H	J	System Inputs
System Waterflow	x	x	x	x	x					System Waterflow
System Tamper Switch			x					x		System Tamper Switch
Low Water Pressure Switch										Low Water Pressure Switch
Manual Pull Stations	x	x	x	x						Manual Pull Stations
Area Smoke Detector	x	x	x	x						Area Smoke Detector
Area Heat Detector										Area Heat Detector
Kitchen Hood System										Kitchen Hood System
Duct Smoke Detector	x					x	x			Duct Smoke Detector
Fire Alarm - AC Failure			x						x	Fire Alarm - AC Failure
Fire Alarm - Low Battery			x						x	Fire Alarm - Low Battery
Signal Line Open Circuit			x						x	Signal Line Open Circuit
Signal Line Ground Fault			x						x	Signal Line Ground Fault
Horn/Strobe Circuit Open			x						x	Horn/Strobe Circuit Open
Horn/Strobe Circuit Ground			x						x	Horn/Strobe Circuit Ground
System Ground Fault			x						x	System Ground Fault
	A	B	C	D	E	F	G	H	J	



Service and Warranty

R.B. Allen Co., Inc. is a UL Certified ISO 9001 registered Fire Alarm Distributor since 1966 with offices located in North Hampton, NH and Woonsocket, RI. The service policies of R.B. Allen Company are no charge to the customer for warranty work including parts and labor for one (1) year from the time of final acceptance.

R.B. Allen Company warranty applies only to the equipment it provides and does not cover defective wiring or equipment provided by the Electrical Contractor.

Service calls resulting from acts of nature, acts of vandalism, or acts which are beyond the control of the equipment manufacturer are excluded under the guarantee and shall be considered a billable call.

R.B. Allen Company factory trained and certified technician will provide job site supervision during installation of the system and perform final connections, testing and adjusting of the Fire Alarm System. They also will instruct the owner's personnel on the operation and maintenance of the fire alarm system.

[Click Here to Return to
Bill of Material/Index](#)



Fire Alarm Permit

If you or the property owner owes real estate or property taxes or user charges on any property within the city, payment arrangements must be made before permits of any kind are accepted.

Installation address: _____ CBL: _____

Exact location: (within structure) _____

Type of occupancy(s) (NFPA & ICC): _____

Building owner: _____

Must be

System Designer (point of contact): _____

Designer phone: _____ E-mail: _____

Installing contractor: _____ Certificate of Fitness No: _____

Contractor phone: _____ E-mail: _____

This is a new application: YES NO

This is an amendment to an existing permit: YES NO Permit no: _____

The following documents shall be provided with this application:

- Floor plans
- Wiring diagram
- Annunciator details
- Equipment data sheets
- Battery & voltage drop calculations
- Input/ Output Matrix
- Designer qualifications
- Electrical Permit Pulled (check alarm/com)

<p>COST OF WORK: _____</p> <p>PERMIT FEE: _____ (\$10 PER \$1,000 + \$30 FOR THE FIRST \$1,000)</p>

The **designer** shall be the responsible party for this application. Download a new copy of this application at www.portlandmaine.gov/fire for every submittal. Submit all plans in electronic PDF in **addition** to full sized plans to the **Building Inspections Department, 389 Congress Street, Room 315, Portland, Maine 04101.**

Prior to acceptance of any fire alarm system, a complete commissioning and acceptance test must be coordinated with all fire system contractors and the Fire Department, and proper documentation of such test(s) provided.

All installation(s) must comply with the *City of Portland Technical Standard for Signaling Systems for the Protection of Life and Property*, available at www.portlandmaine.gov/fire .

<p>Applicant signature: _____ Date: _____</p>

Master Box Approval

Applicant:

Emergency Contact:

App Phone #:

Emergency phone #:

Building Name:

Date of Application:

Building Address:

Billing Address:

Occupancy:

Comments:

Assembly OL>300, 20 unit apartment building, etc.

Applicant completes red box and submits with Fire Alarm Permit

1

FIRE PREVENTION:

Approved

Denied

____/____/____
Date

Fire Prevention Officer

Comments:

2

FIRE ALARM:

Box #: _____

ELECTRICAL DIVISION:

Approved

Denied

Box Type: AES Radio Box /
New

Other

3

Test Date: ____/____/____

In Service Date: ____/____/____

Fire Alarm Technician

AES

Circuit if applicable:

4

FIRE ALARM:

Same Running Assignment As Box: _____

Notifications: All Stations Run Books Digitizer Computer Cad Box Test

South Portland

Other

Dispatcher

5

BILLING:

Entered

Financial Officer

6

FIRE PREVENTION:

Filed ____/____/____
Date

[Click Here to Return to Bill of Material/Index](#)

iO500 Intelligent Life Safety System



Overview

The EST iO500 intelligent life safety system offers the power of high-end intelligent processing in a configuration that delivers an uncomplicated solution for small to mid-sized applications. With intelligent detection, electronic addressing, automatic device mapping, optional Ethernet® connectivity, and a full line of easily-configured option cards and modules, this flexible system offers versatility that benefits building owners and contractors alike.

The iO500 provides one Class A or Class B analog device loop that supports up to 250 device addresses. A second 250-point loop may be added to the iO500 to expand total system capacity to up to 500 device addresses. The panel includes four NACs that may be wired for either Class A or Class B operation.

The iO500 supports a wide range of accessories and related equipment, including:

- Signature Series intelligent modules, detectors, and bases
- R-Series remote annunciators
- option cards that expand system capacity and extend system capabilities.

Features

- Comes standard with one loop (expandable to two) that supports up to 250 (expandable to 500) intelligent devices: each iO500 loop supports up to 125 detectors and up to 125 modules.
- Supports Signature Series intelligent modules and detectors
- Four Class B NACs or two Class A NACs.
- Form C contacts for alarm and trouble, Form A for supervisory
- Electronic addressing with automatic device mapping
- Optional Ethernet port for diagnostics, programming and a variety of system reports
- Two programmable switches with LEDs and custom labeling
- Supports Genesis horn silence over two wires and UL 1971-compliant strobe synchronization
- Supports up to eight serial annunciators, (LCD, LED-only, and graphic interface).
- 1,000 event panel history log
- Can use existing wiring for most retrofit applications
- Upload/download remotely or locally
- Two-level maintenance alert reporting
- Pre-alarm and alarm verification by point
- Adjustable detector sensitivity
- 4 x 20 character backlit LCD display

Application

The iO500 life safety system is a powerful intelligent solution for small to mid-sized buildings. Advanced analog technology delivers the benefits of flexible system installation, while a clean and easy-to-operate user interface makes panel operation and system maintenance quick and intuitive.

The smart choice

Signature Series electronic addressing eliminates the tedium of setting dipswitches, and automatic device mapping ensures that each device resides on the system at its correct location. Meanwhile, innovative programming allows the designer to customize the system to precisely suit the needs of the building owner.

Flexibility built right in

Two fully-programmable front panel switch/LED combinations provide an added measure of flexibility. Their slide-in labels take the mystery out of custom applications, and present a clean finished appearance.

Perfect for retrofits

The iO500 is particularly well-suited to retrofit applications. All connections are made over standard wiring – no shielded cable required. This means that in most situations existing wiring can be used to upgrade a legacy control panel to iO500 technology without the expense or disruption of rewiring the entire building.

Signals with a difference

iO500 NACs are configurable to fully support the advanced signaling technology of Edwards Genesis and Enhanced Integrity notification appliances. These devices offer precision synchronization of strobes to UL 1971 standards. For Genesis devices, enabling this feature allows connected horns to be silenced while strobes on the same two-wire circuit continue to flash until the panel is reset.

Clear-cut remote annunciation

Remote annunciation is a strong suit of the iO500. Up to eight annunciators can be installed on a single system. Compatible annunciators include a range of LED and LCD models that provide zone or point annunciation, as well as common control capabilities.

The iO500 also supports graphic annunciation with optional graphic annunciator interface modules. Each interface provides common control, indicators, and LED drivers. Consult the Ordering Information section for details.

A complete line of accessories

The iO500 life safety system is supported by a complete line of intelligent detectors, modules and related equipment. Consult the Ordering Information section for details.

Operation

The front panel provides an easy-to-use operator's interface, as well as all the necessary controls for front panel programming. A large back-lit 80-character LCD displays system status, event details, and programming prompts. Large tactile control buttons are easy to see in low light conditions, and bright multi-color LEDs offer at-a-glance status indication.

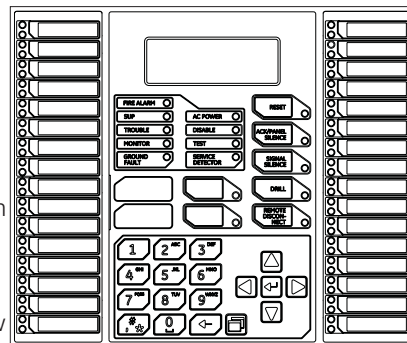

Control buttons

Button	Description
Reset	Initiates a system reset.
ACK/Panel Silence	Silences the panel and remote annunciators during an active trouble, supervisory, or alarm event and acknowledges new event activations.
Signal Silence	<i>Alarm mode:</i> Silences active notification appliances. Pressing Signal Silence a second time turns NACs back on.
Drill	Initiates a drill confirmation. Pressing drill a second time turns off the drill function.
Remote Disconnect	<i>Dialer:</i> Disables or enables dialer. <i>Dialer set to modem only:</i> Disables or enables the common alarm relay.
Left arrow	<i>Display mode:</i> Moves the cursor to the left. <i>Menu mode:</i> Toggles between programming selections.
Right arrow	<i>Display mode:</i> Moves the cursor to the right. <i>Menu mode:</i> Retrieves a programming option's sub menu and toggles between a programming option's selections.
Up arrow	<i>Display mode:</i> Advances to the previous event. <i>Menu mode:</i> Moves the cursor up.
Down arrow	<i>Display mode:</i> Advances to the next event. <i>Menu mode:</i> Moves the cursor down.
Enter	<i>Display mode:</i> Displays selected event details. <i>Menu mode:</i> Retrieves a programming option's sub menu or jumps to the Save function in the menu. <i>Entry mode:</i> Enters the selected data into the system.
Cancel	<i>Display mode:</i> Exits the detailed information display. <i>Menu mode:</i> Exits the current menu level. <i>Entry mode:</i> Clears the current entry.
Menu	<i>Display mode:</i> Enters the menu mode <i>Menu mode:</i> Exits menu mode
Space	Enters a space, such as a space between words.
Alphanumeric keypad	<i>Entry mode:</i> Pressing a button once enters the number on the button. Pressing the button twice enters the secondary value.
Programmable buttons	These buttons can be programmed to control outputs, disable devices or unlatch system outputs. The buttons can be labeled with a slip-in insert.

System LEDs

Led	Description
Fire Alarm	Red LED. On steady when there is an active alarm.
Trouble	Yellow LED. Flashes when there is a fault on a monitored circuit or system component, or when a circuit is disabled.
Sup	Yellow LED. On steady when there is an active supervisory event.
Ac Power	Green LED. On when the panel has AC power.
Disable	Yellow LED. Double-flashes when there is a disabled circuit, alarm relay, or remote annunciator.
Ground Fault	Yellow LED. On steady during an active ground fault.
Test	Yellow LED. Flashes when performing an audible walk test. Steady indicates a silent test.
Monitor	Yellow LED. On steady when there is an active monitor event.
Service Detector	Yellow LED. Indicates that detector needs servicing.
Signal Silence	Yellow LED. On steady indicates that NAC circuits are turned off but the panel is still in alarm.
Remote Disconnect	Yellow LED. On steady indicates that the dialer is disabled or that the alarm relay is enabled or disabled when the dialer is set to modem only.
Drill	Yellow LED. Indicates that the panel is in drill.
Reset	Yellow LED. Indicates that the panel is resetting.
Panel Silence	Yellow LED. Indicates that the panel has been silenced during an active trouble, supervisory, or alarm event and indicates that new event activations have been acknowledged.
User Keys	Yellow LED. Programmable.

Panel Operation Options

Language	English or French
Marketplace	U.S. or Canada
AC fail delay	<i>Off:</i> Off-premise notification of an AC power failure is immediate. <i>1 to 15 hours:</i> Delays the off-premise notification of an AC power failure by the time period selected.
Zone resound	<i>On:</i> NACs resound each time a device in the zone goes into alarm even if they were silenced <i>Off:</i> Inhibits the NACs from turning on again (after they were silenced) when a second device in the zone goes into alarm.
Reset inhibit after NACs turn on	<i>Off:</i> Panel reset is operational immediately. <i>1 minute:</i> Panel reset is inhibited for one minute.
Auto signal silence	<i>Off:</i> Allows immediate silencing of signals from an off-normal condition using the Signal Silence button <i>5 to 30 minutes:</i> Delays the silencing of signals from an off-normal condition by disabling the Signal Silence button for the time period selected.
Day start	Start time for daytime sensitivity
Night start	Start time for nighttime sensitivity
Date	<i>U.S.:</i> MM/DD/YYYY, <i>Canada:</i> DD/MM/YYYY
Sounder Base	Six configuration settings
Mapping	<i>Disabled:</i> Device mapping is not available <i>Enabled:</i> Device mapping is available
LCD banner	Banner text for line one and line two. Each line is capable of up to 20 characters.
Event notification	<i>Zone:</i> When a device is a member of a zone, only the zone information is sent to the LCD display, LEDs, printer, and dialer. <i>Zone/device:</i> Zone information is sent to the LCD display and LEDs. Device information is sent to the printer and dialer. <i>Device:</i> Only device information is reported.

Programming

iO500 life safety systems are simple to set up, yet also offer advanced programming features that put these small building panels into a class of their own. The auto programming feature quickly gets the panel operational using factory default settings. Basic zone and point settings can be programmed easily through the front panel interface, so the system is up and running in no time.

For more advanced system configuration and correlation groups programming, iO500 systems interface to a PC running compatible iO-CU software. This option offers full system configuration in the familiar Windows® operating environment. Connection is typically made to a laptop through the panel's optional RS-232 communications port, which can also be used to connect a system printer.

Among the many innovative features of iO500 control panels is the optional network card. This module provides a standard 10/100 Base T Ethernet® network connection that permits access to the control panel from any remote location with the correct communications protocols. The connection can be used to download to the panel from the iO-CU, or upload and view system reports using the iO-CU.

Available system reports include:

- Correlation groups
- Device maintenance
- Internal status
- System status
- Dialer
- Device details
- History
- System configuration
- Walk test

Dimensions

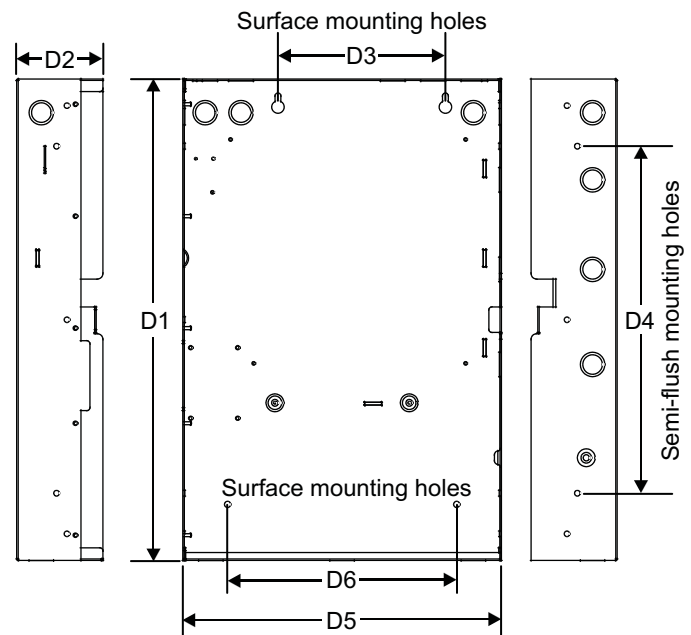

Panel dimensions, in (cm)						
Model	D1*	D2	D3	D4	D5*	D6
iO500	28.0 (71.1)	3.85 (9.8)	9.0 (22.8)	22.0 (55.8)	15.75 (40.0)	10.25 (26.0)

* Add 1-1/2 in. (3.81 cm) to D1 and D5 dimensions for trim kit.

Wiring & Configuration

Notification appliance circuits (TB2)

iO500 control panels come equipped with four notification appliance circuits. Each circuit can be individually configured for continuous, temporal, synchronized, latching, and coded output.

Circuit specifications	
Circuit Type	4 Class B or 2 Class A, 2.5 amps each
Voltage	24 VFWR
Current	6.0 A total, 2.5 A max. per circuit at 120/230 VAC 60 Hz 5.0 A total at 230VAC 50 Hz, 2.5 A max. per circuit
Impedance	26 Ω total, 0.35 μF max
EOLR	15 K Ω, ½ W

Class B wiring

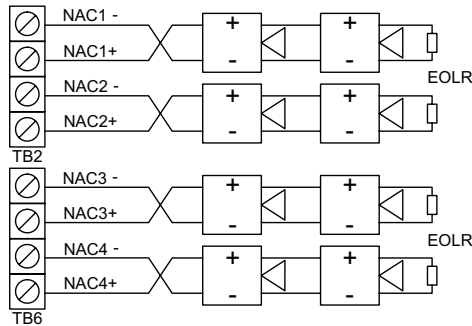

Marking indicates output signal polarity when the circuit is active. Polarity reverses when the circuit is not active. Wire notification appliances accordingly. Notification appliance polarity shown in active state.

Class A wiring

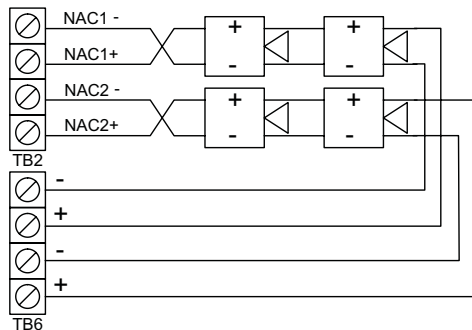

Auxiliary & Smoke power outputs (TB3)

The control panel provides two auxiliary power outputs which can be used for powering ancillary equipment such as remote annunciators and two wire smoke detectors. Aux 2 can be software selected to operate continuous. The circuit is supervised for shorts and grounds.

Note: For a complete list of devices that can be connected to this circuit, refer to the iO Series compatibility list (p/n 3101064).

Circuit specifications	
Circuit voltage range	21.9 to 28.3 V
Resettable circuit (Aux power 2)	24 VDC nominal at 500 mA
Continuous circuit (Aux power 1)	24 VDC nominal at 500 mA. Use this circuit for powering two-wire smoke detectors.

Note: Any current above 0.5 amp connected to both Aux 1 and 2 will reduce the total available NAC power by that amount.

Signature Device loop

The system provides one device loop circuit that can be used with any mix of Signature Series detectors and modules. The loop circuit is supervised for opens, shorts, and grounds.

Circuit specifications	
Device loops	1 loop, expandable to 2, Class A or B, each loop supporting up to 250 device addresses
Communication line voltage	Maximum 20 V peak-to-peak
Circuit current	0.5 A max
Circuit impedance	66Ω total, 0.5 μF, max
Isolators	64 maximum

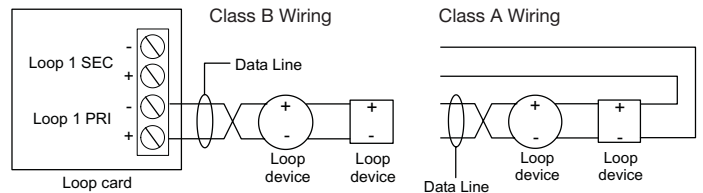

Annunciator loop (TB4)

The control panel provides a connection for up to eight serially driven and supervised remote annunciators.

Circuit specifications	
Device loops	Class B (Style Y) or Class A (Style Z)
Circuit voltage	2.55 V
Circuit current	30 mA max
Circuit impedance	Up to 8 annunciators or 4000 feet

Class B

Class A

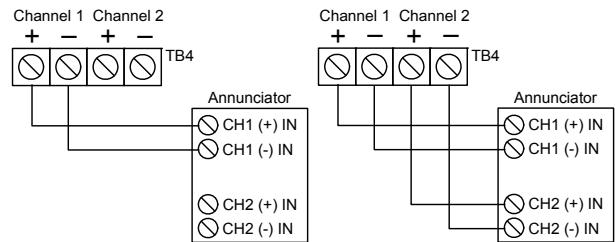

Alarm, trouble, and supervisory relay (TB3)

The trouble relay is normally-open, held closed, and opens on any trouble event or when the panel is de-energized. The supervisory relay is normally-open, and closes on any supervisory event. The alarm relay changes over on any alarm event.

Relay specifications

	Alarm	Trouble	Supervisory
Type	Form C		Form A
Voltage	24 VDC at 1 A resistive		24 VDC at 1 A resistive

Relay circuits can only be connected to power-limited sources.

Option Cards

iO500 panels are supported by a complete line of modules and related equipment that enhance performance and extend system capabilities. Option cards plug directly into the control panel main circuit board or are connected to it with a ribbon cable. After installation, terminals remain accessible. The cabinet provides ample room for wire routing, keeping wiring neat at all times.

SA-ETH Ethernet Interface Card

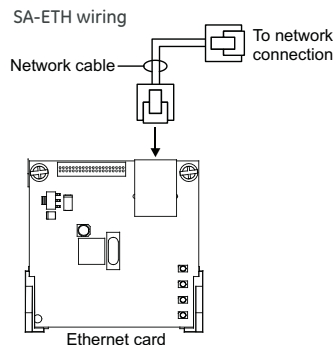

The SA-ETH card provides a standard 10/100 Base T Ethernet network connection for connecting to an intranet, a local network, or the Internet. The card can be used to download configuration programming from the iO-CU to the panel over the network.

The Ethernet card is installed on the plastic assembly and connects to the main circuit board via a ribbon cable.

SA-ETH specifications

Ethernet	10/100 Base T
Operating environment	
Temperature	32 to 120°F (0 to 49°C)
Humidity	0 to 93% RH, noncondensing at 90°F (32°C)

XAL250 Loop Expander Card

The XAL250 Loop Expander Card provides an additional Signature Series device loop on the control panel. The card expands the control panel's device capacity to 500 total device addresses, 250 per loop. The card is compatible with Class B or Class A wiring. It is compatible with iO500 control panels only.

The loop expander card connects to connector J7 on the main circuit board.

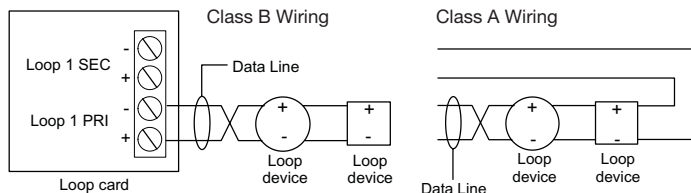

XAL250 specifications

Device addresses on loop	125 detectors and 125 modules
Wiring	Class B (Style Y) or Class A (Style Z)
Operating voltage	20 V peak-to-peak
Operating current	0.5 A total
Circuit impedance	66 Ω, 0.5 μF, max
Terminal rating	12 to 18 AWG (0.75 to 2.5 sq mm)
Operating environment	
Temperature	32 to 120°F (0 to 49°C)
Humidity	0 to 93% RH, noncondensing at 90°F (32°C)

SMK Smoke Power Converter

The SMK Smoke Power Converter Module provides a regulated power source for two-wire smoke circuits connected to a Signature data circuit. The SMK monitors the operating power from the power supply. When power begins to degrade, the SMK provides the necessary operating voltage to the two-wire smoke detection circuits.

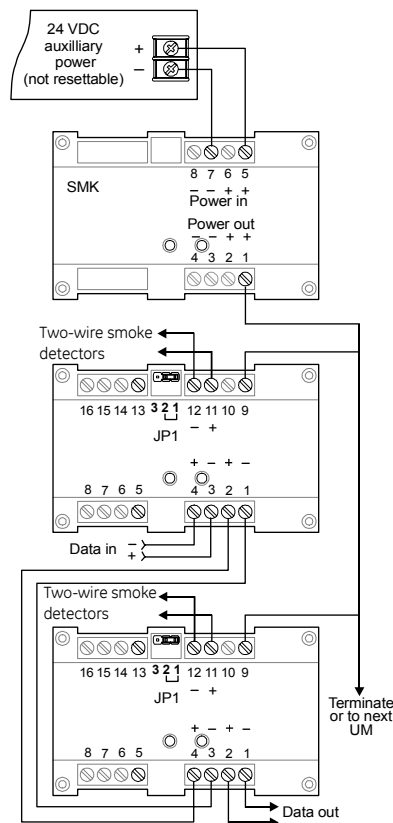

SMK specifications

Input voltage	21.9 to 28.3 VDC (not resettable)
Output voltage	24 VDC nom. at 200 mA, max., special applications
Ground fault impedance	10 k ohm
Operating environment	
Temperature	32 to 120°F (0 to 49°C)
Humidity	0 to 93% RH, noncondensing at 90°F (32°C)
Storage temperature	-4 to 140°F (-20 to 60°C)
Compatible electrical boxes	North American 4 inch square x 2-1/2 in. (64 mm) deep 2 gang box or Standard 4 in. square box 1-1/2 in. (38 mm) deep
Wire size	14, 16, or 18 AWG wire (1.5, 1.0, or 0.75 sq. mm) (Sizes 16 and 18 AWG are preferred)

SA-DACT Dialer

The SA-DACT provides communications between the control panel and the central station over a telephone line system. It transmits system status changes (events) to a compatible digital alarm communicator receiver over the public switched telephone network. The dialer is capable of single, dual, or split reporting of events to two different account and telephone numbers. The modem feature of the SA-DACT can also be used for uploading and downloading panel configuration, history, and current status to a PC running the iO-CU.

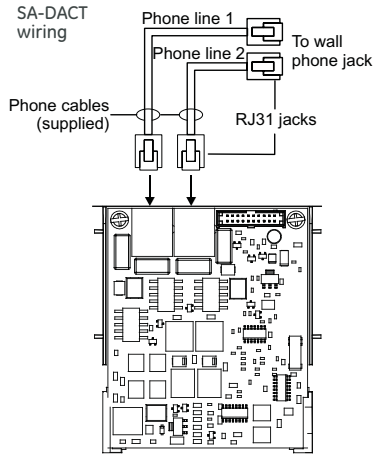

The dialer phone lines connect to connectors on the dialer's main circuit board. Phone line 1 connects to connector J4 and phone line 2 connects to connector J1.

The SA-DACT queues messages and transmits them based on priority (alarm, supervisory, trouble, and monitor). Activations are transmitted before restorations.

The SA-DACT is installed on the plastic assembly and connects to the main circuit board via a ribbon cable.

SA-DACT specifications

Phone line type	One or two loop-start lines on a public, switched network
Phone line connector	RJ-31/38X (C31/38X)
Communication formats	Contact ID (SIA DC-05)
Operating environment	
Temperature	32 to 120°F (0 to 49°C)
Humidity	0 to 93% RH, noncondensing at 90°F (32°C)

Compatible DACRs

Receiver	Models	Formats
Ademco	685	Contact ID
FBII	CP220	Contact ID
Osborne-Hoffman	OH 2000	Contact ID
Radionics	D6600	Contact ID
Silent Knight	9800	Contact ID
Sur-Gard	SG-MLR1, MLR2	Contact ID

SA-232 RS-232 interface

The SA-232 card provides an RS-232 interface with iO500 panels. It can be used for connecting a printer to the control panel to print system events. The card also can be used for connecting a computer to download a configuration program from the iO-CU to the control panel.

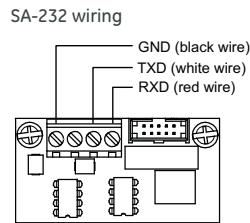

The RS-232 card is installed on the plastic assembly and connects to the main circuit board via a ribbon cable.

SA-232 specifications

Operating voltage	Standard EIA-232
Terminal rating	12 to 18 AWG (0.75 to 2.5 sq mm)
Operating environment	
Temperature	32 to 120°F (0 to 49°C)
Humidity	0 to 93% RH, noncondensing at 90°F (32°C)

Specifications

Device loops	1 loop, expandable to 2, Class A or B, each loop supporting up to 250 device addresses
NAC circuits	4 Class B or 2 Class A, 2.5 amps each
Power supply	6.0 A total, 2.5 A max. per circuit at 120/230 VAC 60 Hz 5.0 A total at 230VAC 50 Hz, 2.5 A max. per circuit 0.5 amps aux power
NAC Operating voltage	24 VDC. NAC minimum voltage: 19.5 VDC @ 20.4 V battery voltage
Loop circuit operating voltage	20 V peak-to-peak
SLC Primary power	120 VAC, 60 Hz, 230 VAC 50-60 Hz
Aux Power 1 (Continuous circuit)	24 VDC nominal at 500 mA. A SMK module is required when using the SIGA-UM module to support two-wire smoke detectors.
Aux Power 2 (Resettable circuit)	24 VDC nominal at 500 mA
Auxiliary output	19 to 25.7 VDC
Base panel current draw	Standby: 172 mA Alarm: 267 mA
Panel History Log	1,000 events

Battery placement	iO500 cabinets accommodate up to 18 A/H batteries. Use an external cabinet for larger battery sizes.
Batteries	Batteries must be sealed lead acid type only. Maximum charging capacity = 26 Ah.
Loop circuit	Maximum loop resistance: 66 Ω. Maximum loop capacitance: 0.5 μF. Style 4, 6, and 7 wiring. 64 isolators maximum.
SIGA-UM/SIGA-MAB	1.5 mA (see the UL and ULC compatibility list for the maximum quantity of detectors per circuit)
Compatibility ID	100
Alarm contact	Form C 24 VDC @ 1 A (resistive load)
Trouble contact	Form C 24 VDC @ 1 A (resistive load)
Supervisory contact	Form A 24 VDC @ 1 A (resistive load)
Environmental	Temperature: 0 to 49°C (32 to 120°F). Humidity: 0 to 93% RH, noncondensing
Terminal rating	All terminals rated for 12 to 18 AWG (0.75 to 2.5 mm ²)
Serial communications	Voltage: 2.55 V. Current: 30 mA max
Remote annunciator	8 drops max, RS-485 Class A or B
Input zones	32 max.
Agency Listing	UL, CSFM and ULC

Ordering Information

Part	Description
iO500 Intelligent Multi-Loop Analog Systems	
iO500G	1 Loop system, 500 point capacity, 4 NACs, gray door, surface mount enclosure, 115 Vac, English.
iO500G-2	1 Loop system, 500 point capacity, 4 NACs, gray door, surface mount enclosure, 230 Vac, English.
iO500GC	Canada only: 1 Loop system, 500 point capacity, 4 NACs, 16-zone LED display, grey door, surface mount, 115 Vac, English.
iO500G-F	Canada only: 1 Loop system, 500 point capacity, 4 NACs, 16-zone LED display, grey door, surface mount, 115VAC, French.
iO500GD	1 Loop system, 500 point capacity, two-line dialer, 4 NACs, Gray door, surface mount enclosure, 115VAC transformer, English.
iO500R	1 Loop system, 500 point capacity, 4 NACs, red Door, surface mount enclosure, 115VAC transformer, English.
iO500R-2	1 Loop system, 500 point capacity, 4 NACs, red door, surface mount enclosure, 230VAC transformer, English.
iO500RD	1 Loop system, 500 point capacity, two-line dialer, 4 NACs, Red Door, surface mount enclosure, 115VAC transformer, English.
iO500G-SP	1 Loop system, 500 point capacity, 4 NACs, gray door, surface mount enclosure, 115vac, Spanish.
iO500G-2-SP	1 Loop system, 500 point capacity, 4 NACs, gray door, surface mount enclosure, 230vac, Spanish.
iO500G-PG	1 Loop system, 500 point capacity, 4 NACs, gray door, surface mount enclosure, 115vac, Portuguese.
iO500G-2-PG	1 Loop system, 500 point capacity, 4 NACs, gray door, surface mount enclosure,, 230vac, Portuguese.
SA-TRIM2	Flush mount trim, black

Replacement Electronics

500elec-iO	Replacement electronics kit, complete motherboard and user interface, English
500elec-iO-SP	Replacement electronics kit, complete motherboard and user interface, Spanish
500elec-iO-PG	Replacement electronics kit, complete motherboard and user interface, Portuguese
500elec-iO-FR	Replacement electronics kit, complete motherboard and user interface, Canadian French

Option Cards

SA-DACT	Dual Line Dialer/Modem, supports Contact ID, mounts in cabinet on base plate.
SA-232	Serial Port (RS-232), for connection to printers & computers, mounts in cabinet to base plate
SA-ETH	Ethernet Port, Slave, mounts in cabinet on base plate.
XAL250	Signature Loop Expansion Module. Adds second loop to iO500 systems, 250 point capacity. Mounts in cabinet on main board.
D16L-iO-2	LED Annunciator module, 16 X 2-LED zones (4 programmable for sup). Mounts in cabinet to right of LCD display for zones 17-32.
D16L-iO-1	LED Annunciator module, 16 X 2-LED zones (4 programmable for sup). Mounts in cabinet to left of LCD display for zones 1-16.
D8RY-iO-2	Canada only: LED Annunciator module, two LEDs per zone, 16 zones (4 alarm only, 8 supervisory only, 4 alarm or supervisory). Mounts in cabinet to right of LCD display for zones 17-32.
D8RY-iO-1	Canada only: LED Annunciator module, two LEDs per zone, 16 zones (4 alarm only, 8 supervisory only, 4 alarm or supervisory). Mounts in cabinet to left of LCD display for zones 1-16.

Remote Annunciators (refer to Data Sheet 85005-0128)

LCD Remote Annunciators (mount to standard 4" square electrical box)

RLCD	Remote Annunciator, 4X20 LCD & Common Indicators for displaying system status. Gray housing.
RLCD-R	Remote Annunciator, 4X20 LCD & Common Indicators for displaying system status. Red housing.
RLCD-C	Remote Annunciator, 4X20 LCD. Common controls and status indicators. Gray housing.
RLCD-CR	Remote Annunciator, 4X20 LCD. Common controls and status indicators. Red housing.
RLCD-SP	Remote Annunciator, 4X20 LCD. Common system status indicators. White housing. Spanish.
RLCD-PG	Remote Annunciator, 4X20 LCD. Common system status indicators. White housing. Portuguese.
RLCD-C-SP	Remote Annunciator, 4X20 LCD. Common controls and status indicators. White housing. Spanish.
RLCD-C-PG	Remote Annunciator, 4X20 LCD. Common controls and status indicators. White housing. Portuguese.
RLED-C-SP	Remote Annunciator, common controls and status indicators. 16 groups w/2 LEDs each for zone display. White housing. Spanish.
RLED-C-PG	Remote Annunciator, common controls and status indicators. 16 groups w/2 LEDs each for zone display. White housing. Portuguese.

For French common control, add suffix F to model number.

LED Remote Annunciators & Expander (mount to standard 4" square electrical box)

RLED-C	Remote Annunciator. Common controls and status indicators with 16 X 2-LED groups for zone display. Gray housing.
RLED-CF	Remote Annunciator. Common controls and status indicators with 16 X 2-LED groups for zone display. Gray housing, French.
RLED-CR	Remote Annunciator. Common controls and status indicators with 16 X 2-LED groups for zone display. Red housing.
RLED24	Remote Annunciator Zone expander. 24 X 2-LED groups with custom label areas for display of alarm and trouble. Gray housing.
RLED24R	Remote Annunciator Zone expander. 24 X 2-LED groups with custom label areas for display of alarm and trouble. Red housing.

Remote Annunciator Cabinets & Accessories

RA-ENC1	Remote Annunciator Enclosure, key locked with plexiglass window for one RLCD(C) or RLED(C).
RA-ENC2	Remote Annunciator Enclosure, key locked with plexiglass window with space for 2 of either RLCDx, RLEDx or RLED24.
RA-ENC3	Remote Annunciator Enclosure, key locked with plexiglass window with space for 3 of either RLCDx, RLEDx or RLED25.
RKEY	Keypad, single gang, provides key operated enable or disable of common controls on RLCD or RLED units.
LSRA-SB	Surface Mount Box - for R Series single units.

Programming Tools

iO-CU	EST Series configuration and diagnostics utility.
260097	RS232 cable, 4 conductor, DB9 PC interface



Detection & alarm since 1872

U.S.
T 888-378-2329
F 866-503-3996

Canada
Chubb Edwards
T 519 376 2430
F 519 376 7258

Southeast Asia
T : +65 6391 9300
F : +65 6391 9306

India
T : +91 80 4344 2000
F : +91 80 4344 2050

Australia
T +61 3 9239 1200
F +61 3 9239 1299

Europe
T +32 2 725 11 20
F +32 2 721 86 13

Latin America
T 305 593 4301
F 305 593 4300

utcfireandsecurity.com

© 2010 UTC Fire & Security.
All rights reserved.

Intelligent Analog Addressable Devices & Accessories

Part #	Description	Ship wt.
Intelligent Detectors & Bases		
SIGA-HFS	Intelligent Fixed Temperature Heat Detector	
SIGA-HRS	Intelligent Fixed Temperature/Rate-of-Rise Heat Detector	
SIGA-IPHS	Intelligent 4D Multisensor Detector	
SIGA-IPHSB	Intelligent 4D Multisensor Detector (Black)	0.5 (0.23)
SIGA-PHS	Intelligent 3D Multisensor Detector	
SIGA-PS	Intelligent Photoelectric Detector	
SIGA-IS	Intelligent Ionization Detector	
SIGA-SD	Intelligent Duct Detector	
SIGA-SB	Detector Mounting Base	
SIGA-SB4	4-inch Detector Mounting Base c/w SIGA-TS Trim Skirt	
SIGA-RB	Detector Mounting Base w/Relay	
SIGA-RB4	4-inch Detector Mounting Base /w Relay c/w SIGA-TS Trim Skirt	0.2 (0.09)
SIGA-IB	Detector Mounting Base w/Fault Isolator	
SIGA-IB4	4-inch Detector Mounting Base w/ Fault Isolator c/w SIGA-TS Trim Skirt	
SIGA-LED	Remote Alarm LED	
SIGA-AB4G	Audible (Sounder) Base	0.3 (0.15)
SIGA-TS4	Trim Skirt (supplied with 4-inch bases)	0.1 (.04)
Modules		
SIGA-CC1	Single Input Signal Module (Standard Mount)	0.5 (0.23)
SIGA-MCC1	Single Input Signal Module (UIO Mount)	0.18 (0.08)
SIGA-CC1S	Synchronization Output Module (Standard Mount)	0.5 (0.23)
SIGA-MCC1S	Synchronization Output Module (UIO Mount)	0.18 (0.08)
SIGA-CC2	Dual Input Signal Module (Standard Mount)	0.5 (0.23)
SIGA-MCC2	Dual Input Signal Module (UIO Mount)	0.18 (0.08)
SIGA-CR	Control Relay Module (Standard Mount)	0.4 (0.15)
SIGA-MCR	Control Relay Module (UIO Mount)	0.18 (0.08)
SIGA-CRR	Polarity Reversal Relay Module (Standard Mount)	0.4 (0.15)
SIGA-MCRR	Polarity Reversal Relay Module (UIO Mount)	0.18 (0.08)
SIGA-RM1	Riser Monitor Module (Standard Mount)	0.5 (0.23)
SIGA-MRM1	Riser Monitor Module (Plug-in)	0.18 (0.08)
SIGA-IO	Input/Output Module (Standard Mount)	0.34 (0.15)
SIGA-MIO	Input/Output Module (Plug-in)	0.22 (0.10)
SIGA-MAB	Universal Class A/B Module (Plug-in)	0.18 (0.08)
SIGA-CT1	Single Input Module	0.4 (0.15)
SIGA-CT2	Dual Input Module	0.4 (0.15)
SIGA-MCT2	Dual Input Plug-in (UIO) Module	0.1 (0.05)
SIGA-IM	Fault Isolator Module	0.5 (0.23)
SIGA-MM1	Monitor Module	0.4 (.15)
SIGA-WTM	Waterflow/Tamper Module	0.4 (.15)
SMK	Smoke Power Converter Module	0.4 (0.15)
SIGA-UIO2R	Universal Module Board w/Riser Inputs - Two Module Positions	0.32 (0.15)
SIGA-UIO6R	Universal Module Board w/Riser Inputs - Six Module Positions	0.62 (0.28)
SIGA-UIO6	Universal Module Board - Six Module Positions	0.56 (0.25)
Accessories		
GCI	Graphic Annunciator Driver, provides outputs for common indicators and 32 alarm/supv zones as well as inputs for common switches. Provided with a snap track for mounting in custom graphic enclosures.	
CTM	City Tie Module. Provides connection to a local energy fire alarm box.	0.6 (0.3)
RPM	Reverse Polarity Module	3.0 (1.36)
BC-1	Battery Cabinet. 14.0" x 18.25" x 7.25". Holds 2 12V24A batteries.	50.0 (22.7)
BC-1R	Battery Cabinet - Red. 14.0" x 18.25" x 7.25". Holds 2 12V24A batteries.	50.0 (22.7)
MFC-A	Multifunction Fire Cabinet, 8" x 14" x 3.5" - RED.	20.6 (9.4)
PT-1S	System Printer - Desktop style.	36.6 (16.6)

[Click Here to Return to Bill of Material/Index](#)

[Click Here to Return to
Bill of Material/Index](#)

Sealed Lead-Acid Batteries



Overview

Rechargeable sealed lead-acid batteries are ideal for use as a secondary (standby) power source as defined by NFPA 72. Their low maintenance and high energy density make them ideal for fire alarm signaling applications.

Standard Features

- Rechargeable
- Non-spillable
- Non-hazardous
- Low maintenance
- High energy density

Application

When multiple power supplies are provided, each power supply's battery requirements should be calculated individually. Consult the specific system manual to determine battery capacity requirements.

Safety Information

Due to a battery's low internal resistance and high power density, high levels of short circuit current can develop across battery terminals. Put on protective eye covering and remove all jewelry before working on batteries. Do not rest tools or cables on the battery, and only use insulated tools. Follow all manufacturers installation instructions and diagrams when installing or maintaining batteries.



Detection & alarm since 1872

U.S.
T 888-378-2329
F 866-503-3996

Canada
Chubb Edwards
T 519 376 2430
F 519 376 7258

Southeast Asia
T : +65 6391 9300
F : +65 6391 9306

India
T : +91 80 4344 2000
F : +91 80 4344 2050

Australia
T +61 3 9239 1200
F +61 3 9239 1299

Europe
T +32 2 725 11 20
F +32 2 721 86 13

Latin America
T 305 593 4301
F 305 593 4300

utcfireandsecurity.com

© 2010 UTC Fire & Security.
All rights reserved.

Specifications

Case Material	ABS Thermoplastic
Regulatory Information	DOT Class 60, Batteries, non-hazardous, non-spillable
Operating Environment	32° F to 120° F (0° C to 49° C) 0 to 93% RH, Non-condensing

Ordering Information

Catalog Number	Description	Shipping Weight, lb (kg)
12V1A2	1.2 Ah Sealed Lead Acid Battery - 12 Vdc	1.25 (0.57)
12V4A	4.5 Ah Sealed Lead Acid Battery - 12 Vdc	5 (2.27)
12V6A5	7.2 Ah Sealed Lead Acid Battery - 12 Vdc	6 (2.72)
6V8A	8 Ah Sealed Lead Acid Battery - 6 Vdc	4 (1.81)
6V10A	12 Ah Sealed Lead Acid Battery - 6 Vdc	5 (2.27)
12V10A	11 Ah Sealed Lead Acid Battery - 12 Vdc	10 (4.45)
12V17A	18 Ah Sealed Lead Acid Battery - 12 Vdc	13 (5.90)
12V24A	26 Ah Sealed Lead Acid Battery - 12 Vdc	20 (9.07)
12V40A	40 Ah Sealed Lead Acid Battery - 12 Vdc	32 (14.51)
12V50A	50 Ah Sealed Lead Acid Battery - 12 Vdc	40 (18.14)
12V65A	65 Ah Sealed Lead Acid Battery - 12 Vdc	49 (22.23)

[Click Here to Return to
Bill of Material/Index](#)

Manual Pull Stations

SIGA-270, SIGA-270P,
SIGA-278



Overview

The SIGA-270 and SIGA-278 series Manual Pull Stations are part of EST's Signature Series system. The SIGA-270 Fire Alarm Manual Pull Stations feature our very familiar teardrop shape. They are made from die-cast zinc and finished with red epoxy powder-coat paint complemented by aluminum colored stripes and markings. With positive pull-lever operation, one pull on the station handle breaks the glass rod and turns in a positive alarm, ensuring protection plus fool-proof operation. Presignal models (SIGA-270P) are equipped with a general alarm (GA) keyswitch for applications where two stage operation is required. The up-front highly visible glass rod discourages tampering, but is not required for proper operation.

EST's double action single stage SIGA-278 station is a contemporary style manual station made from durable red colored lexan. To initiate an alarm, first lift the upper door marked "LIFT THEN PULL HANDLE", then pull the alarm handle.

Standard Features

Note: Some features described here may not be supported by all control systems. Check your control panel's Installation and Operation Guide for details.

- **Traditional familiar appearance**

SIGA-270 models feature our familiar teardrop design with simple positive pull action and sturdy die-cast metal body.

- **One stage (GA), two stage (pre-signal), and double action models**

SIGA-270 models are available for one or two stage alarm systems. The single stage double action SIGA-278 features a rugged Lexan housing with keyed reset mechanism.

- **Break glass operation**

An up-front visible glass rod on the SIGA-270 discourages tampering.

- **Intelligent device with integral microprocessor**

All decisions are made at the station allowing lower communication speed while substantially improving control panel response time. Less sensitive to line noise and loop wiring properties; twisted or shielded wire is not required.

- **ADA Compliant**

Meets ADA requirements for manual pull stations.

- **Electronic Addressing with Non-volatile memory**

Permanently stores programmable address, serial number, type of device, and job number. Automatically updates historic information including hours of operation, last maintenance date, number of alarms and troubles, and time and date of last alarm.

- **Automatic device mapping**

Each station transmits wiring information to the loop controller regarding its location with respect to other devices on the circuit.

- **Stand-alone operation**

The station inputs an alarm even if the loop controller's polling interrogation stops.

- **Diagnostic LEDs**

Status LEDs; flashing GREEN shows normal polling; flashing RED shows alarm state.

- **Designed for high ambient temperature operation**

Install in ambient temperatures up to 120 °F (49 °C).

Application

The operating characteristics of the fire alarm stations are determined by their sub-type code or "Personality Code". NORMALLY-OPEN ALARM - LATCHING (Personality Code 1) is assigned by the factory; no user configuration is required. The device is configured for Class B IDC operation. An ALARM signal is sent to the loop controller when the station's pull lever is operated. The alarm condition is latched at the station.

Compatibility

Signature Series manual stations are compatible only with EST's Signature Loop Controller.

Warnings & Cautions

This device will not operate without electrical power. As fires frequently cause power interruption, we suggest you discuss further safeguards with your local fire protection specialist.

Testing & Maintenance

To test (or reset) the station simply open the station and operate the exposed switch. The SIGA-270 series are opened with a tool; the SIGA-278 requires the key which is supplied with that station.

The station's automatic self-diagnosis identifies when it is defective and causes a trouble message. The user-friendly maintenance program shows the current state of each Signature series device and other pertinent messages. Single devices may be deactivated temporarily, from the control panel. Availability of maintenance features is dependent on the fire alarm system used.

Scheduled maintenance (Regular or Selected) for proper system operation should be planned to meet the requirements of the Authority Having Jurisdiction (AHJ). Refer to current NFPA 72 and ULC CAN/ULC 536 standards.

Typical Wiring

The fire alarm station's terminal block accepts #18 AWG (0.75mm²) to #12 AWG (2.5mm²) wire sizes. See Signature Loop Controller catalog sheet for detailed wiring requirement specifications.

Wiring Notes

1. Refer to Signature Loop Controller manual for maximum wire distance.
2. All wiring is power limited and supervised.

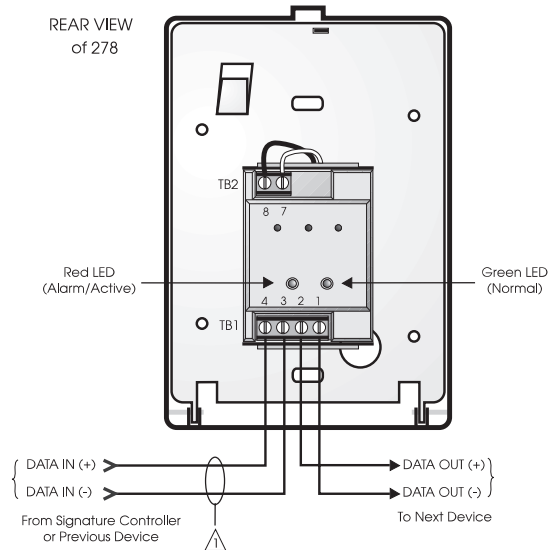

Figure 4. Single Stage Systems

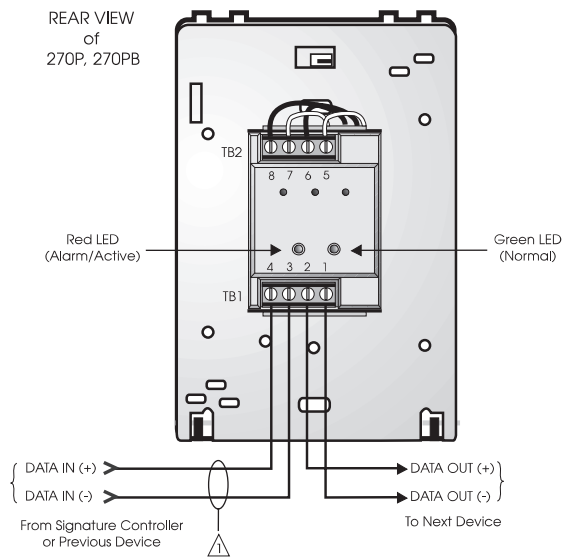

Figure 5. Two Stage Systems

Installation

Single-stage Signature Series fire alarm manual pull stations mount to North American 2½ inch (64 mm) deep 1-gang boxes.

Two stage presignal (270P) models require 1½ inch (38 mm) deep 4-inch square boxes with 1-gang, ½-inch raised covers. Openings must be angular. *Rounded openings are not acceptable.* Recommended box: Steel City Model 52-C-13; in Canada, use Iberville Model CI-52-C-49-1/2.

All models include terminals are suited for #12 to #18 AWG (2.5 mm² to 0.75 mm²) wire size. Edwards recommends that these fire alarm stations be installed according to latest recognized edition of national and local fire alarm codes.

Electronic Addressing: The loop controller electronically addresses each manual station, saving valuable time during system commissioning. Setting complicated switches or dials is not required. Each station has its own unique serial number stored in its on-board memory. The loop controller identifies each device on the loop and assigns a “soft” address to each serial number. If desired, the stations can be addressed using the SIGA-PRO Signature Program/Service Tool.

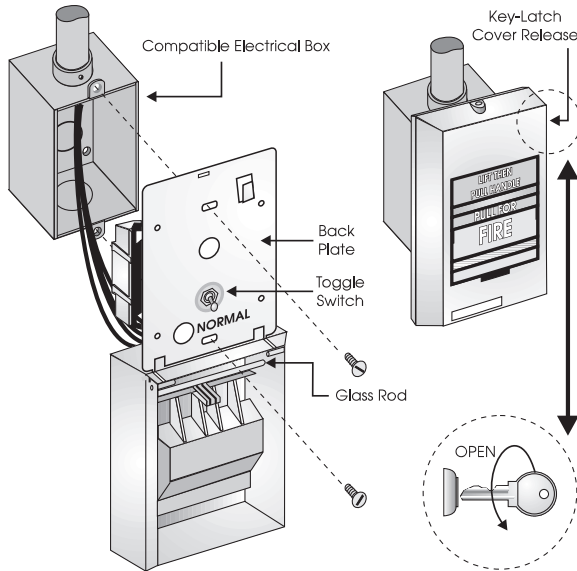

Figure 1. SIGA-278 installation

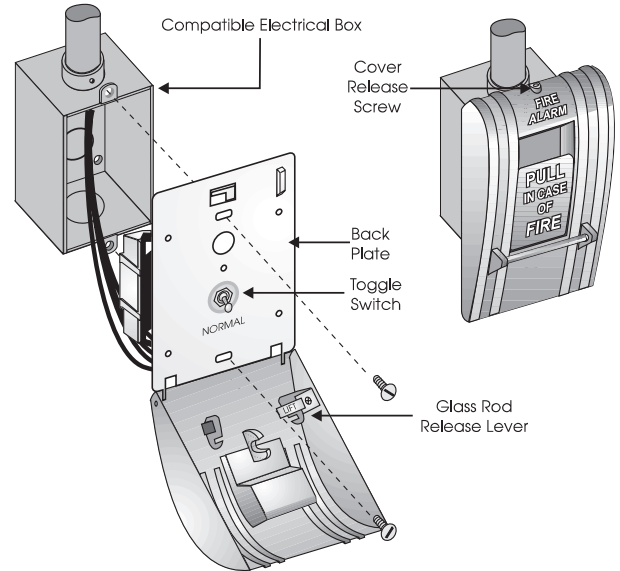

Figure 2. SIGA-270, SIGC-270F, SIGC-270B installation

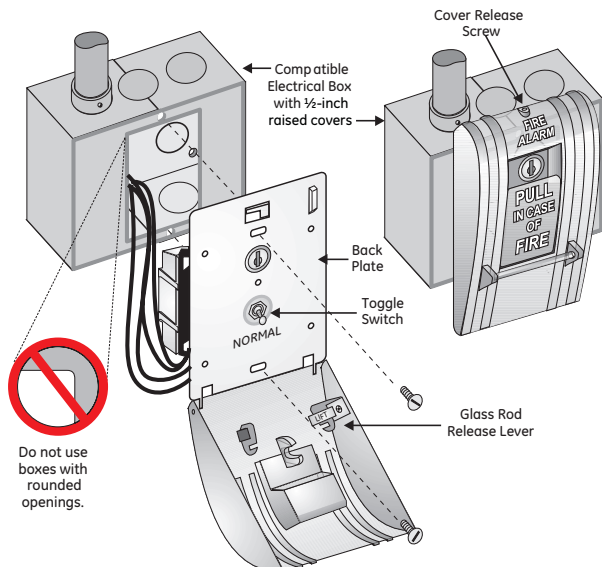

Figure 3. SIGA-270P, SIGC-270PB installation



Detection & alarm since 1872

U.S.
T 888-378-2329
F 866-503-3996

Canada
Chubb Edwards
T 519 376 2430
F 519 376 7258

Southeast Asia
T : +65 6391 9300
F : +65 6391 9306

India
T : +91 80 4344 2000
F : +91 80 4344 2050

Australia
T +61 3 9239 1200
F +61 3 9239 1299

Europe
T +32 2 725 11 20
F +32 2 721 86 13

Latin America
T 305 593 4301
F 305 593 4300

utcfireandsecurity.com

© 2010 UTC Fire & Security.
All rights reserved.

Specifications

Catalog Number	SIGA-270, SIGC-270F, SIGC-270B	SIGA-270P, SIGC-270PB	SIGA-278
Description	Single Action - One Stage	Single Action - Two Stage (Presignal)	Double Action - One Stage
Addressing Requirements	Uses 1 Module Address	Uses 2 Module Addresses	Uses 1 Module Address
Operating Current	Standby = 250µA Activated = 400µA	Standby = 396µA Activated = 680µA	Standby = 250µA Activated = 400µA
Construction & Finish	Diecast Zinc - Red Epoxy with aluminum markings		Lexan - Red with white markings
Type Code	Factory Set		
Operating Voltage	15.2 to 19.95 Vdc (19 Vdc nominal)		
Storage and Operating Environment	Operating Temperature: 32°F to 120°F (0°C to 49°C) Storage Temperature: -4°F to 140°F (-20°C to 60°C) Humidity: 0 to 93% RH		
LED Operation	On-board Green LED - Flashes when polled On-board Red LED - Flashes when in alarm Both LEDs - Glow steady when in alarm (stand-alone)		
Compatibility	Use With: Signature Loop Controller		
Agency Listings	UL, ULC (note 1), MEA, CSFM		

Note: SIGC-270F, SIGC-270B and SIGC-270PB are ULC listed only. Suffix "F" indicates French markings. Suffix "B" indicates English/French bilingual markings.

Ordering Information

Catalog Number	Description	Ship Wt. lbs (kg)
SIGA-270	One Stage Fire Alarm Station, English Markings - UL/ULC Listed	
SIGC-270F	One Stage Fire Alarm Station, French Markings - ULC Listed	
SIGC-270B	One Stage Fire Alarm Station, French/English Markings - ULC Listed	
SIGA-270P	Two Stage (Presignal) Fire Alarm Station, English Markings - UL/ULC Listed	1 (0.5)
SIGC-270PB	Two Stage (Presignal) Fire Alarm Station, French/English Markings - ULC Listed	
SIGA-278	Double Action (One Stage) Fire Alarm Station, English Markings - UL/ULC Listed	

Accessories

32997	GA Key w/Tag - for pre-signal station (CANADA ONLY)	
276-K2	GA Key - for pre-signal station (USA ONLY)	
276-K1	Station Reset Key, Supplied with all Key Reset Stations	
27165	12 Glass Rods - for SIGA-270 series (CANADA ONLY)	0.1 (.05)
270-GLR	20 Glass Rods - for SIGA-270 series (USA ONLY)	
276-GLR	20 Glass Rods - for SIGA-278 series	
276B-RSB	Surface Mount Box, Red - for SIGA pull stations	1 (0.6)

[Click Here to Return to Bill of Material/Index](#)

Intelligent Smoke Detector with Optional CO Sensor

SIGA2-PS, SIGA2-PCOS



Overview

Signature Series SIGA2-P(CO)S photoelectric detectors bring advanced sensing technology to a practical design that increases efficiency, saves installation time, cuts costs, and extends life safety and property protection capabilities. Continuous self-diagnostics ensure reliability over the long-haul, while innovative field-replaceable smoke chambers make detector maintenance literally a snap. With its modular CO sensor, this detector pulls double-duty — continually monitoring the environment for signs of smoke, as well as its invisible yet deadly companion, carbon monoxide.

Like all Signature Series detectors, the SIGA2-P(CO)S is an intelligent device that gathers analog information from its smoke and CO sensor (if present), converting this data into digital signals. To make an alarm decision, the detector's on-board microprocessor measures and analyzes sensor readings and compares this information to historical data. Digital filters remove signal patterns that are not typical of fires, thus virtually eliminating unwanted alarms.

The SIGA2-PCOS includes an advanced carbon monoxide sensor and daughterboard. When the electrochemical cell reaches its end of life after approximately six years, the detector signals a trouble condition to the control panel. The sensor/daughterboard module is field-replaceable.

Standard Features

- Optical smoke sensing technology with optional carbon monoxide sensor
- Field-replaceable smoke chamber
- Field-replaceable carbon monoxide sensor/daughterboard module
- Uses existing wiring
- Automatic device mapping
- Ground fault detection by module
- Up to 250 devices per loop
- Two levels of environmental compensation
- Two levels of dirty detector warning
- Twenty pre-alarm settings
- Five sensitivity settings
- Non-volatile memory
- Electronic addressing
- Environmental compensation
- Identification of dirty or defective detectors
- Automatic day/night sensitivity adjustment
- Bicolor (green/red) status LED
- Standard, relay, fault isolator, and audible mounting bases

Application

Smoke detection

The SIGA2-PS detects extremely small particles of combustion and triggers an alarm at the first sign of smoke. Thanks to its high-performance forward scattering reflective response technology, the photoelectric smoke sensor responds quickly and reliably to a wide range of fire types, especially slow burning fires fuelled by combustibles typically found in modern multi-use buildings.

Carbon monoxide detection

CO detection has rapidly become a standard part of life safety strategies everywhere. Monitored CO detection is becoming mandated with increasing frequency in all types of commercial applications, but particularly in occupancies such as hotels, rooming houses, dormitories, day care facilities, schools, hospitals, assisted living facilities, and nursing homes. In fact, more than half of the U.S. population already lives in states requiring the installation of CO detectors in some commercial occupancies. This is because carbon monoxide is the leading cause of accidental poisoning deaths in America. Known as the "Silent Killer," CO is odorless, tasteless, and colorless. It claims nearly 500 lives, and results in more than 15,000 hospital visits annually.

Installation

Signature Series detectors mount to North American 1-gang boxes, 3-1/2 inch or 4 inch octagon boxes, and to 4 inch square electrical boxes 1-1/2 inches (38 mm) deep. They mount to European BESA and 1-gang boxes with 60.3 mm fixing centers. See mounting base installation and wiring for more information.

Testing & Maintenance

Each detector automatically identifies when it is dirty or defective and causes a "dirty detector" message. The detector's sensitivity measurement can also be transmitted to the loop controller. A sensitivity report can be printed to satisfy NFPA sensitivity measurements which must be conducted at the end of the first year and every two years thereafter.

The user-friendly maintenance program shows the current state of each detector and other pertinent messages. Single detectors may be turned off temporarily from the control panel. Availability of maintenance features is dependent on the fire alarm system used. When the CO sensor's electrochemical cell reaches its end of life, the detector signals a trouble condition to the control panel. The sensor/daughterboard module is field-replaceable. Scheduled maintenance (Regular or Selected) for proper detector operation should be planned to meet the requirements of the Authority Having Jurisdiction (AHJ). Refer to current NFPA 72, NFPA 720, and ULC CAN/ULC 536 standards.

This detector will NOT sense fires that start in areas where smoke cannot reach the detector. Smoke from fires in walls, roofs, or on the opposite side of closed doors may not reach the detector to alarm it.

Sensing and reporting technology

The microprocessor in each detector provides four additional benefits - Self-diagnostics and History Log, Automatic Device Mapping, Stand-alone Operation and Fast, Stable Communication.

Self-diagnostics and History Log - Each Signature Series detector constantly runs self-checks to provide important maintenance information. The results of the self-check are automatically updated and permanently stored in the detector's non-volatile memory.

Automatic Device Mapping - The loop controller learns where each device's serial number address is installed relative to other devices on the circuit. The mapping feature provides supervision of each device's installed location to prevent a detector from being reinstalled (after cleaning etc.) in a different location from where it was originally.

Stand-alone Operation - A decentralized alarm decision by the detector is guaranteed. On-board intelligence permits the detector to operate in stand-alone mode. If loop controller CPU communications fail for more than four seconds, all devices on that circuit go into stand-alone mode. The circuit acts like a conventional alarm receiving circuit.

Fast Stable Communication - On-board intelligence means less information needs to be sent between the detector and the loop controller. Other than regular supervisory polling response, the detector only needs to communicate with the loop controller when it has something new to report.

Accessories

Detector mounting bases have wiring terminals that are accessible from the "room-side" after mounting the base to the electrical box. The bases mount to North American 1-gang boxes and to 3½ inch or 4 inch octagon boxes, 1½ inches (38 mm) deep. They also mount to European BESA and 1-gang boxes with 60.3 mm fixing centers. The SIGA-SB4, SIGA-RB4, and SIGA-IB4 mount to North American 4 inch sq. electrical boxes in addition to the above boxes. They include the SIGA-TS4 Trim Skirt which is used to cover the "mounting ears" on the base. The SIGA-AB4G mounts to a 4" square box only.

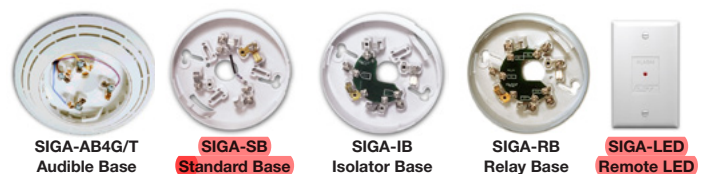

Remote LED SIGA-LED - The remote LED connects to the SIGA-SB or SIGA-SB4 Standard Base only. It features a North American size 1-gang plastic faceplate with a white finish and red alarm LED.

SIGA-TS4 Trim Skirt - Supplied with 4 inch bases, it can also be ordered separately to use with the other bases to help hide surface imperfections not covered by the smaller bases.

SIGA-AB4G and SIGA-AB4GT - These sounder bases are designed for use where localized or group alarm signaling is required. The SIGA-AB4G is compatible with Signature Series smoke and heat detectors. The SIGA-AB4GT sounder base, when used with the SIGA-TCDR Temporal Pattern Generator module, adds an audible output function to any Signature Series detector, including fire and CO detectors.

Typical Wiring

The detector mounting bases accept #18 AWG (0.75mm²), #16 (1.0mm²), #14 AWG (1.5mm²), and #12 AWG (2.5mm²) wire sizes.

Note: Sizes #16 AWG (1.0mm²) and #18 AWG (0.75mm²) are preferred for ease of installation. See Signature Loop Controller catalog sheet for detailed wiring requirement specifications.

Standard Detector Base, SIGA-SB, SIGA-SB4

This is the basic mounting base for Edwards Signature Series detectors. The SIGA-LED Remote LED is supported by the Standard Base.

Term	Description
1	Not Used
2	DATA IN/OUT (+)
3	Not Used
4	DATA IN (-)
5	Remote LED (+)
6	Remote LED (-)
7	Not Used
8	DATA OUT (-)

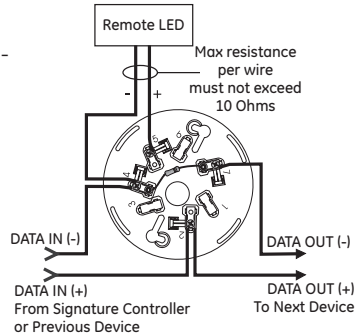

Isolator Detector Base, SIGA-IB, SIGA-IB4

This base includes a built-in line fault isolator for use on Class A circuits. A detector must be installed for it to operate. The isolator base does not support the SIGA-LED Remote LED.

The isolator operates as follows:

- a short on the line causes all isolators to open within 23 msec
- at 10 msec intervals, beginning on one side of the Class A circuit nearest the loop controller, the isolators close to provide the next isolator down the line with power
- when the isolator next to the short closes, reopens within 10 msec.

The process repeats beginning on the other side of the loop controller.

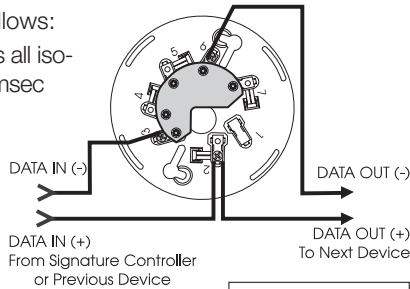

Term	Description
1	Not Used
2	DATA IN/OUT (+)
3	DATA IN (-)
4	Not Used
5	Not Used
6	DATA OUT (-)
7	Not Used

Relay Detector Base, SIGA-RB, SIGA-RB4

This base includes a relay. Normally open or closed operation is selected during installation.

The dry contact is rated for 1 amp (pilot duty) @ 30 Vdc. The relay's position is supervised to avoid accidentally jarring it out of position. The SIGA-RB can be operated as a control relay if programmed to do so at the control panel (EST3 V.2 only). The relay base does not support the SIGA-LED Remote LED.

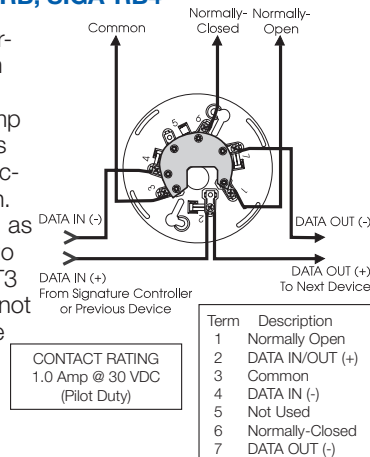

Term	Description
1	Normally Open
2	DATA IN/OUT (+)
3	Common
4	DATA IN (-)
5	Not Used
6	Normally-Closed
7	DATA OUT (-)

Audible Detector Base for CO and Fire Detectors, SIGA-AB4GT

The Signature Series AB4GT sounder base, when used with the SIGA-TCDR Temporal Pattern Generator, adds an audible output function to any Signature Series detector. For more information on this device, refer to *Data Sheet 85001-0623 -- Sounder Base for CO and Fire Detectors*.

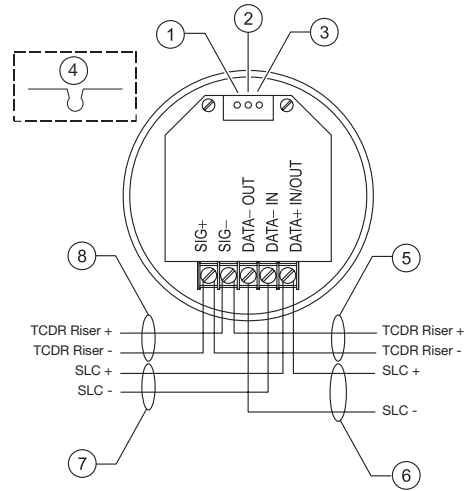

1. Volume setting. Default is high volume. For low volume, cut trace per item 4.
2. Reserved for future use. Do not cut.
3. Reserved for future use. Do not cut.
4. To configure output volume, cut trace as shown.
5. To next SIGA-AB4GT sounder base or EOL relay.
6. SLC_OUT to next intelligent addressable device.
7. SLC_IN from intelligent addressable controller or previous device.
8. From SIGA-TCDR Temporal Pattern Generator or previous SIGA-AB4GT sounder base.

Audible Detector Base, SIGA-AB4G

This base is designed for use where localized or group alarm signaling is required. When the detector senses an alarm condition, the audible base emits a local alarm signal. The optional SIGA-CRR Polarity Reversal Relay can be used for sounding to other audible bases on the same 24 Vdc circuit.

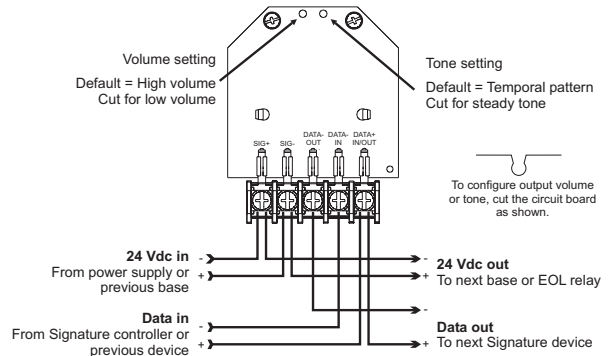

Relay and Audible Bases operate as follows:

- at system power-up or reset, the relay is de-energized
- when a detector is installed in the base with the power on, the relay energizes for four seconds, then de-energizes
- when a detector is removed from a base with the power on, the relay is de-energized
- when the detector enters the alarm state, the relay is energized.



Detection & alarm since 1872

U.S.
T 888 378 2329
F 866 503 3996

Canada
Chubb Edwards
T 519 376 2430
F 519 376 7258

Southeast Asia
T : +65 6391 9300
F : +65 6391 9306

India
T : +91 80 4344 2000
F : +91 80 4344 2050

Australia
T +61 3 9239 1200
F +61 3 9239 1299

Europe
T +32 2 725 11 20
F +32 2 721 86 13

Latin America
T 305 593 4301
F 305 593 4300

utcfireandsecurity.com

© 2010 UTC Fire & Security.
All rights reserved.

Compatibility

SIGA2-P(CO)S detectors are compatible only with the Signature Loop Controller.

Warnings & Cautions

This detector will not operate without electrical power. As fires frequently cause power interruption, we suggest you discuss further safeguards with your fire protection specialist.

This detector will NOT sense fires that start in areas where smoke cannot reach the detector. Smoke from fires in walls, roofs, or on the opposite side of closed doors may not reach the detector to alarm it.

Specifications

	SIGA2-PS	SIGA2-PCOS
Normal operating current	45 µA	70 µA
Alarm current	18 mA	18 mA
Standalone alarm current	45 µA	70 µA
Operating voltage	15.20 to 19.95 VDC	
Air velocity	0 to 4,000 ft./min (0 to 20 m/s).	
Construction	High impact engineering polymer	
Wall mounting	Maximum 12 in (305 mm) from ceiling	
Mounting	Plug-in	
Shipping weight	0.44 lb. (164 g)	
Compatible bases	See Ordering Information	
Operating environment	32 to 120°F (0 to 49°C), 0 to 93% RH, noncondensing	
Storage temperature	-4 to 140°F (-20 to 60°C)	
Environmental compensation	Automatic	

Ordering Information

Catalog Number	Description	Ship Wt. lbs (kg)
SIGA2-PS	Intelligent Photoelectric Detector	0.4 (0.16)
SIGA2-PCOS	Intelligent Photoelectric Detector with carbon monoxide sensor	0.4 (0.16)
SIGA2-PCOS-CA	Intelligent Photoelectric Detector with carbon monoxide sensor (for use in Canadian markets only).	0.4 (0.16)

Accessories		
SIGA-SB	Detector Mounting Base - Standard	
SIGA-SB4	4-inch Detector Mounting Base c/w Trim Skirt	
SIGA-RB	Detector Mounting Base w/Relay	
SIGA-RB4	4-inch Detector Mounting Base w/Relay, c/w Trim Skirt	0.2 (.09)
SIGA-IB	Detector Mounting Base w/Fault Isolator	
SIGA-IB4	4-inch Detector Mounting Base w/ Fault Isolator, c/w Trim Skirt	
SIGA-LED	Remote Alarm LED (not for EN54 applications)	
SIGA-AB4G	Audible (Sounder) Base for Fire Detectors	0.3 (0.15)
SIGA-AB4GT	Audible (Sounder) Base for CO and Fire Detectors	0.3 (0.15)
SIGA-TCDR	Temporal Pattern Generator	0.3 (0.15)
SIGA-TS4	Trim Skirt (supplied with 4-inch bases)	0.1 (.04)
2-SPRC1*	Replacement Smoke Chamber (for SIGA2-PS detectors)	0.1 (.04)
2-SPRC2*	Replacement Smoke Chamber (for SIGA2-PCOS detectors)	0.1 (.04)
2-CORPL*	Replacement CO Sensor	0.1 (.04)

*Release pending.

[Click Here to Return to Bill of Material/Index](#)

Intelligent Heat Detectors with Optional CO Sensors

SIGA2-HFS, SIGA2-HRS, SIGA2-HCOS



Overview

Signature Series fixed temperature and rate-of-rise heat detectors bring advanced sensing technology to a practical design that increases efficiency, saves installation time, cuts costs, and extends property protection capabilities. Continuous self-diagnostics ensure reliability over the long-haul, while the latest thermister technology makes these detectors ideal wherever dependable heat detection is required. With their modular CO sensor, these devices pull double-duty — continually monitoring the environment for heat from combustion, as well as its invisible yet deadly companion, carbon monoxide.

Like all Signature Series detectors, these are intelligent devices that gather analog information from their heat and CO sensor (if present), converting this data into digital signals. To make an alarm decision, the detector's on-board microprocessor measures and analyzes sensor readings and compares this information to historical data. Digital filters remove signal patterns that are not typical of fires, thus virtually eliminating unwanted alarms.

The SIGA2-HCOS is a fixed temperature heat detector that includes an advanced carbon monoxide sensor and daughterboard. When the electrochemical cell reaches its end of life after approximately six years, the detector signals a trouble condition to the control panel. The sensor/daughterboard module is field-replaceable.

Standard Features

Note: Some features described here may not be supported by all control systems. Check your control panel's Installation and Operation Guide for details.

- Fixed temperature or rate-of-rise heat detection with optional carbon monoxide sensor
- Field-replaceable carbon monoxide sensor/daughterboard module
- Uses existing wiring
- Automatic device mapping
- Ground fault detection by module
- Up to 250 devices per loop
- Non-volatile memory
- Electronic addressing
- Bicolor (green/red) status LED
- Standard, relay, fault isolator, and audible mounting bases
- 50 foot (15.2 meter) spacing
- 15 °F (8 °C) per minute rate-of-rise alarm point (HRS)
- 135 °F (57 °C) fixed temperature alarm point (HFS/HCOS)

Application

Heat detection

SIGA2-HRS rate-of-rise heat detectors provide a 15 °F (9 °C) per minute rate-of-rise heat sensor for the detection of heat due to fire. The heat sensor monitors the temperature of the air and determines whether an alarm should be initiated.

SIGA2-HFS and SIGA2-HCOS fixed temperature heat detectors provide a 135°F (57°C) fixed-temperature heat sensor for the detection of heat due to fire. The heat sensor monitors the temperature of the air and determines whether an alarm should be initiated.

Carbon monoxide detection

The SIGA2-HCOS includes a replaceable chemical cell for the detection of carbon monoxide (CO). CO detection has rapidly become a standard part of life safety strategies everywhere. Monitored CO detection is becoming mandated with increasing frequency in all types of commercial applications, but particularly in occupancies such as hotels, rooming houses, dormitories, day care facilities, schools, hospitals, assisted living facilities, and nursing homes. In fact, more than half of the U.S. population already lives in states requiring the installation of CO detectors in some commercial occupancies. This is because carbon monoxide is the leading cause of accidental poisoning deaths in America. Known as the “Silent Killer,” CO is odorless, tasteless, and colorless. It claims nearly 500 lives, and results in more than 15,000 hospital visits annually.

Installation

Signature Series detectors mount to North American 1-gang boxes, 3-1/2 inch or 4 inch octagon boxes, and to 4 inch square electrical boxes 1-1/2 inches (38 mm) deep. They mount to European BESA and 1-gang boxes with 60.3 mm fixing centers. See mounting base installation and wiring for more information.

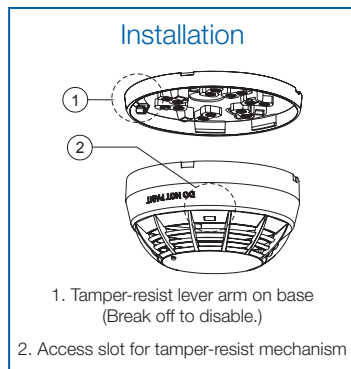

Testing & Maintenance

The user-friendly maintenance program shows the current state of each detector and other pertinent messages. Single detectors may be turned off temporarily from the control panel. Availability of maintenance features is dependent on the fire alarm system used. When the CO sensor's electrochemical cell reaches its end of life, the detector signals a trouble condition to the control panel. The sensor/daughterboard module is field-replaceable. Scheduled maintenance (Regular or Selected) for proper detector operation should be planned to meet the requirements of the Authority Having Jurisdiction (AHJ). Refer to current NFPA 72, NFPA 720, and ULC CAN/ULC 536 standards.

Compatibility

SIGA2-PS detectors are compatible only with the Signature Loop Controller.

Sensing and reporting technology

The microprocessor in each detector provides four additional benefits - Self-diagnostics and History Log, Automatic Device Mapping, Stand-alone Operation and Fast, Stable Communication.

Self-diagnostics and History Log - Each Signature Series detector constantly runs self-checks to provide important maintenance information. The results of the self-check are automatically updated and permanently stored in the detector's non-volatile memory

Automatic Device Mapping - The loop controller learns where each device's serial number address is installed relative to other devices on the circuit. The mapping feature provides supervision of each device's installed location to prevent a detector from being reinstalled (after cleaning etc.) in a different location from where it was originally.

Stand-alone Operation - A decentralized alarm decision by the detector is guaranteed. On-board intelligence permits the detector to operate in stand-alone mode. If loop controller CPU communications fail for more than four seconds, all devices on that circuit go into stand-alone mode. The circuit acts like a conventional alarm receiving circuit.

Fast Stable Communication - On-board intelligence means less information needs to be sent between the detector and the loop controller. Other than regular supervisory polling response, the detector only needs to communicate with the loop controller when it has something new to report.

Accessories

Detector mounting bases have wiring terminals that are accessible from the “room-side” after mounting the base to the electrical box. The bases mount to North American 1-gang boxes and to 3½ inch or 4 inch octagon boxes, 1½ inches (38 mm) deep. They also mount to European BESA and 1-gang boxes with 60.3 mm fixing centers. The SIGA-SB4, SIGA-RB4, and SIGA-IB4 mount to North American 4 inch sq. electrical boxes in addition to the above boxes. They include the SIGA-TS4 Trim Skirt which is used to cover the “mounting ears” on the base. The SIGA-AB4G mounts to a 4” square box only.

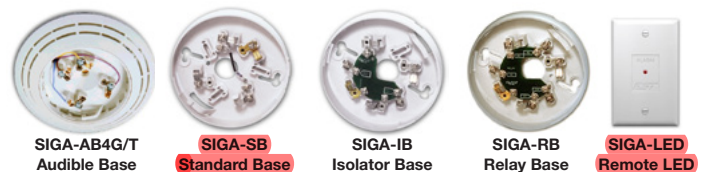

Remote LED SIGA-LED - The remote LED connects to the SIGA-SB or SIGA-SB4 Standard Base only. It features a North American size 1-gang plastic faceplate with a white finish and red alarm LED.

SIGA-TS4 Trim Skirt - Supplied with 4 inch bases, it can also be ordered separately to use with the other bases to help hide surface imperfections not covered by the smaller bases.

SIGA-AB4G and SIGA-AB4GT - These sounder bases are designed for use where localized or group alarm signaling is required. The SIGA-AB4G is compatible with Signature Series smoke and heat detectors. The SIGA-AB4GT sounder base, when used with the SIGA-TCDR Temporal Pattern Generator module, adds an audible output function to any Signature Series detector, including fire and CO detectors.

Typical Wiring

The detector mounting bases accept #18 AWG (0.75mm²), #16 (1.0mm²), #14 AWG (1.5mm²), and #12 AWG (2.5mm²) wire sizes.

Note: Sizes #16 AWG (1.0mm²) and #18 AWG (0.75mm²) are preferred for ease of installation. See Signature Loop Controller catalog sheet for detailed wiring requirement specifications.

Standard Detector Base, SIGA-SB, SIGA-SB4

This is the basic mounting base for Edwards Signature Series detectors. The SIGA-LED Remote LED is supported by the Standard Base.

Term	Description
1	Not Used
2	DATA IN/OUT (+)
3	Not Used
4	DATA IN (-)
5	Remote LED (+)
6	Remote LED (-)
7	Not Used
8	DATA OUT (-)

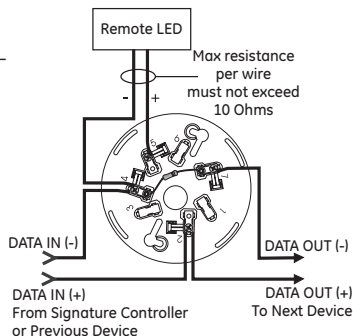

Isolator Detector Base, SIGA-IB, SIGA-IB4

This base includes a built-in line fault isolator for use on Class A circuits. A detector must be installed for it to operate. The isolator base does not support the SIGA-LED Remote LED.

The isolator operates as follows:

- a short on the line causes all isolators to open within 23 msec
- at 10 msec intervals, beginning on one side of the Class A circuit nearest the loop controller, the isolators close to provide the next isolator down the line with power
- when the isolator next to the short closes, reopens within 10 msec.

The process repeats beginning on the other side of the loop controller.

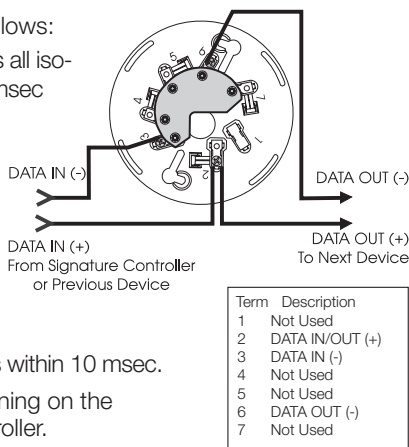

Term	Description
1	Not Used
2	DATA IN/OUT (+)
3	DATA IN (-)
4	Not Used
5	Not Used
6	DATA OUT (-)
7	Not Used

Relay Detector Base, SIGA-RB, SIGA-RB4

This base includes a relay. Normally open or closed operation is selected during installation. The dry contact is rated for 1 amp (pilot duty) @ 30 Vdc. The relay's position is supervised to avoid accidentally jarring it out of position. The SIGA-RB can be operated as a control relay if programmed to do so at the control panel (EST3 V.2 only). The relay base does not support the SIGA-LED Remote LED.

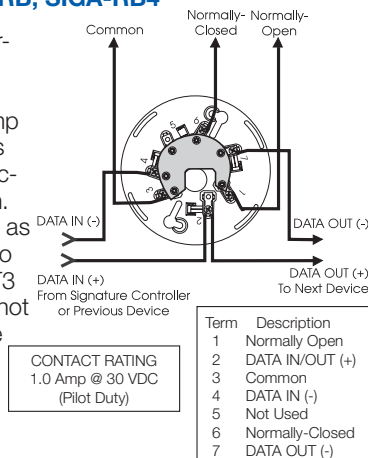

CONTACT RATING
1.0 Amp @ 30 VDC
(Pilot Duty)

Term	Description
1	Normally Open
2	DATA IN/OUT (+)
3	Common
4	DATA IN (-)
5	Not Used
6	Normally-Closed
7	DATA OUT (-)

Audible Detector Base for CO and Fire Detectors, SIGA-AB4GT

The Signature Series AB4GT sounder base, when used with the SIGA-TCDR Temporal Pattern Generator, adds an audible output function to any Signature Series detector. For more information on this device, refer to *Data Sheet 85001-0623 -- Sounder Base for CO and Fire Detectors*.

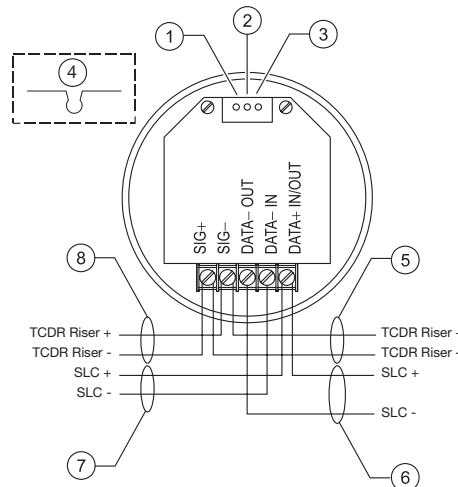

1. Volume setting. Default is high volume. For low volume, cut trace per item 4.
2. Reserved for future use. Do not cut.
3. Reserved for future use. Do not cut.
4. To configure output volume, cut trace as shown.
5. To next SIGA-AB4GT sounder base or EOL relay.
6. SLC_OUT to next intelligent addressable device.
7. SLC_IN from intelligent addressable controller or previous device.
8. From SIGA-TCDR Temporal Pattern Generator or previous SIGA-AB4GT sounder base.

Audible Detector Base, SIGA-AB4G

This base is designed for use where localized or group alarm signaling is required. When the detector senses an alarm condition, the audible base emits a local alarm signal. The optional SIGA-CRR Polarity Reversal Relay can be used for sounding to other audible bases on the same 24 Vdc circuit.

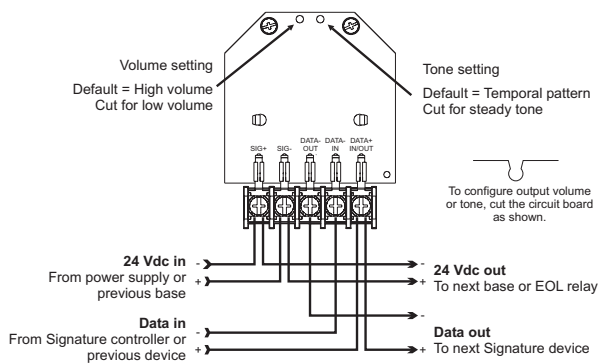

Relay and Audible Bases operate as follows:

- at system power-up or reset, the relay is de-energized
- when a detector is installed in the base with the power on, the relay energizes for four seconds, then de-energizes
- when a detector is removed from a base with the power on, the relay is de-energized
- when the detector enters the alarm state, the relay is energized.



Detection & alarm since 1872

U.S.
T 888 378 2329
F 866 503 3996

Canada
Chubb Edwards
T 519 376 2430
F 519 376 7258

Southeast Asia
T : +65 6391 9300
F : +65 6391 9306

India
T : +91 80 4344 2000
F : +91 80 4344 2050

Australia
T +61 3 9239 1200
F +61 3 9239 1299

Europe
T +32 2 725 11 20
F +32 2 721 86 13

Latin America
T 305 593 4301
F 305 593 4300

utcfireandsecurity.com

© 2010 UTC Fire & Security.
All rights reserved.

Warnings & Cautions

- This detector does not operate without electrical power. As fires frequently cause power interruption, discuss further safeguards with the local fire protection specialist.
- This detector does not sense fires in areas where heat cannot reach the detector. Heat from fires in walls, roofs, or on the opposite side of closed doors may not reach the detector.
- This heat detector by itself does not provide life safety protection Use this detector with ionization and/or photoelectric smoke detectors.
- This detector does not detect oxygen levels, smoke, toxic gases, or flames. Use this device as part of a broad-based life safety program which includes a variety of information sources pertaining to heat and smoke levels, extinguishment systems, visual and audible devices, and other safety measures.
- Independent studies indicate that heat detectors should only be used when property protection alone is involved. Never rely on heat detectors as the sole means of fire protection.

Specifications

	SIGA2-HRS	SIGA2-HFS	SIGA2-HCOS
Normal operating current	45 µA	45 µA	45 µA
Standalone alarm current	18 mA	18 mA	18 mA
Alarm Current	45 µA	45 µA	45 µA
Actual alarm point	15°F (8°C)/min.	130 to 140°F (54 to 60°C)	
Operating voltage	15.20 to 19.95 VDC		
Maximum spacing	50 ft. (15.2 m) centers*		
Construction	High impact engineering polymer		
Mounting	Plug-in		
Shipping weight	0.44 lb. (164 g)		
Compatible bases	See Ordering Information		
Operating environment	32 °F to 100 °F (0 °C to 38 °C), 0 to 93% RH, noncondensing		
Storage temperature	- 4 °F to 140 °F (- 20 °C to 60 °C)		

*When replacing SIGA-HRS/HFS ensure spacing is 50ft or less.

Ordering Information

Catalog Number	Description	Ship Wt. lbs (kg)
SIGA2-HRS	Intelligent rate-of-rise heat detector	0.4 (0.16)
SIGA2-HFS	Intelligent fixed temperature heat detector	0.4 (0.16)
SIGA2-HCOS	Intelligent fixed temperature heat detector with CO sensor	0.4 (0.16)
SIGA2-HCOS-CA	Intelligent fixed temperature heat detector with CO sensor (for use in Canadian markets only)	0.4 (0.16)

Accessories		
SIGA-SB	Detector Mounting Base - Standard	
SIGA-SB4	4-inch Detector Mounting Base c/w Trim Skirt	
SIGA-RB	Detector Mounting Base w/Relay	
SIGA-RB4	4-inch Detector Mounting Base w/Relay, c/w Trim Skirt	0.2 (.09)
SIGA-IB	Detector Mounting Base w/Fault Isolator	
SIGA-IB4	4-inch Detector Mounting Base w/ Fault Isolator, c/w Trim Skirt	
SIGA-LED	Remote Alarm LED (not for EN54 applications)	
SIGA-AB4G	Audible (Sounder) Base for Fire Detectors	0.3 (0.15)
SIGA-AB4GT	Audible (Sounder) Base for CO and Fire Detectors	0.3 (0.15)
SIGA-TCDR	Temporal Pattern Generator	0.3 (0.15)
SIGA-TS4	Trim Skirt (supplied with 4-inch bases)	0.1 (.04)
2-CORPL*	Replacement CO Sensor	0.1 (.04)

*Release pending.

[Click Here to Return to Bill of Material/Index](#)

[Click Here to Return to Bill of Material/Index](#)

Intelligent Duct Smoke Detector

SIGA-SD

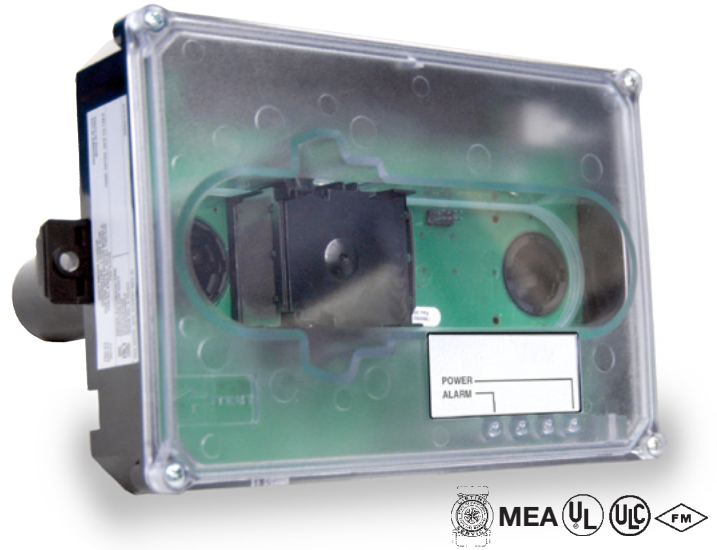

Overview

The Edwards *SuperDuct* Signature Series smoke detector is the most advanced and most reliable device in its class. Designed for easy installation and superb reliability, *SuperDuct* represents the perfect balance of practical design and advanced technology.

SuperDuct detectors feature a unique design that speeds installation and simplifies maintenance. Removable dust filters, conformally coated circuit boards, and optional water-resistant gaskets keep contaminants away from components, ensuring years of trouble-free service. When cleaning is required, the assemblies come apart easily and snap back together in seconds.

A **Signature Series photoelectric sensor** is incorporated into the design of each SIGA-SD duct smoke detector. This sensor inherits the power and benefits of this exceptional line of intelligent devices.

Signature Series sensors gather analog information from their smoke sensing elements and convert it into digital signals. The sensor measures and analyses these signals and compares the information to historical readings and time patterns to make an alarm decision. Digital filters remove signal patterns that are not typical of fires, which virtually eliminates unwanted alarms.

WARNING: Duct detectors have specific limitations. Duct detectors are not a substitute for an open area smoke detector. Duct detectors are not a substitute for early warning detection or a replacement for a building's regular fire detection system. Smoke detectors are not designed to detect toxic gases which can build up to hazardous levels in some fires. These devices will not operate without electrical power. As fires frequently cause power interruptions, Edwards suggests you discuss further safeguards with your local fire protection specialist.

Standard Features

- Less than 2" deep for easy installation and applications where space is tight
- -4°F to 158°F (-20°C to 70°C) operating range with 100 ft/min. to 4,000 ft/min air velocity rating assures reliability under harsh environmental conditions
- Status LEDs remain visible through clear assembly cover
- Cover monitor switch for added security
- Standard sampling tube spacing for easy drop-in migration from other detectors
- Sampling tube can be installed with or without the cover in place and can be rotated in 45-degree increments to ensure proper alignment with duct airflow
- 15.2 to 19.95 Vdc operation
- Magnet-activated test switch
- One Form C auxiliary alarm relay for controlling ancillary equipment (e.g., HVAC controls)
- No special tools required for easy access to field connections
- Signature Series intelligence
- Environmental compensation with differential sensing for reliable, stable, and drift-free sensitivity
- Wide 0.79% to 2.46% obscuration/ft. smoke sensitivity
- Identification of dirty or defective detectors

Application

SuperDuct detectors are ideally suited to duct smoke detection applications where early indication of combustion is required within the confined space of ventilation ductwork. Its primary purpose is to provide early warning of an impending fire and to prevent smoke from circulating throughout the building. It is typically used to detect smoke in the supply side of the HVAC system but can provide supervision of the return side as well.

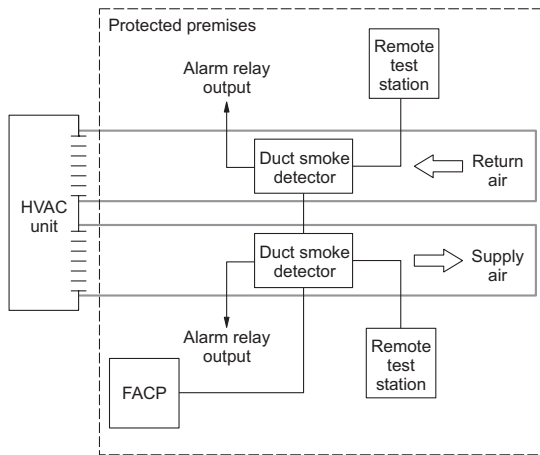

SuperDuct detectors continually sample air flow in the HVAC duct and initiate an alarm condition whenever smoke is detected. An alarm is activated when the quantity (percent obscuration) of combustion products in that air sample exceeds the detector's sensitivity setting.

Signature Series Intelligence

Like all Signature detectors, the SIGA-SD features electronic addressing and issues a dirty sensor warning when it reaches its preset limit. The dirty sensor warning indicates the sensor is operating within its specified limits but is in need of servicing. When the detector's ability to compensate for environmental changes has reached its limit, the duct smoke detector signals a trouble condition.

The SIGA-SD also uses differential sensing to prevent gradual environmental changes from triggering unwanted alarms. A rapid change in environmental conditions, such as smoke from a fire, causes the detector to signal an alarm state, but dust and debris accumulated over time does not change alarm sensitivity.

Each Signature Series *SuperDuct* detector contains a microprocessor that performs comprehensive self-diagnostics and stores the results in nonvolatile memory. Stored results include details such as hours of operation, last maintenance date, and number of alarms and troubles. This information can be retrieved and reviewed when desired.

Detector Configuration

The detector assembly cover provides easy access to the smoke sensor, its wiring connections, sample and exhaust tubes, and the smoke chamber itself.

Air enters the detector's sensing chamber through a sampling tube (ordered separately) that extends into the duct and is directed back into the ventilation system through an exhaust tube (included). The difference in air pressure between the two tubes pulls the sampled air through the sensing chamber. When a sufficient amount of smoke is detected in the sensing chamber, the detector initiates an alarm.

The sampling tube may be installed from either the duct side of the assembly or from inside the sensor compartment, as preferred by the installer. (The exhaust tube must be installed from the duct side.) Sampling tubes may be rotated in 45-degree increments so that air-holes can be aligned to allow the unit to be mounted at virtually any angle relative to the air flow.

In installations where the duct smoke detector's controls and indicators are hidden from view, a remote test station or an LED indicator can be connected to the detector to provide these functions.

Remote Test Stations



Labor-saving Remote Test/Reset stations provide alarm testing from the convenience of a remote location. Tests can be performed quickly and safely – without having to climb to the roof. Magnetically-operated and key-operated one-gang models are available. Signature *SuperDuct* detectors are also compatible with SIGA-LED remote alarm LED.

Air velocity in the duct as low as 100 ft/min. maintains adequate air flow into the sensor smoke chamber through air holes in the air sampling tube and discharges through the exhaust tube. *SuperDuct* air sampling tubes must be installed with the inlet holes facing the airstream. Sampling tubes may be rotated in 45-degree increments so that air-holes can be aligned to allow the unit to be mounted in virtually any angle relative to the airflow.

SuperDuct sensors are engineered to operate optimally under the harsh environmental conditions frequently found in HVAC ductwork. Nonetheless, before installing the detector, test the duct air velocity, temperature, and humidity to verify that it is within the operating range of the *SuperDuct* detector. Consult the *SuperDuct* installation sheet for details.

Dimensions

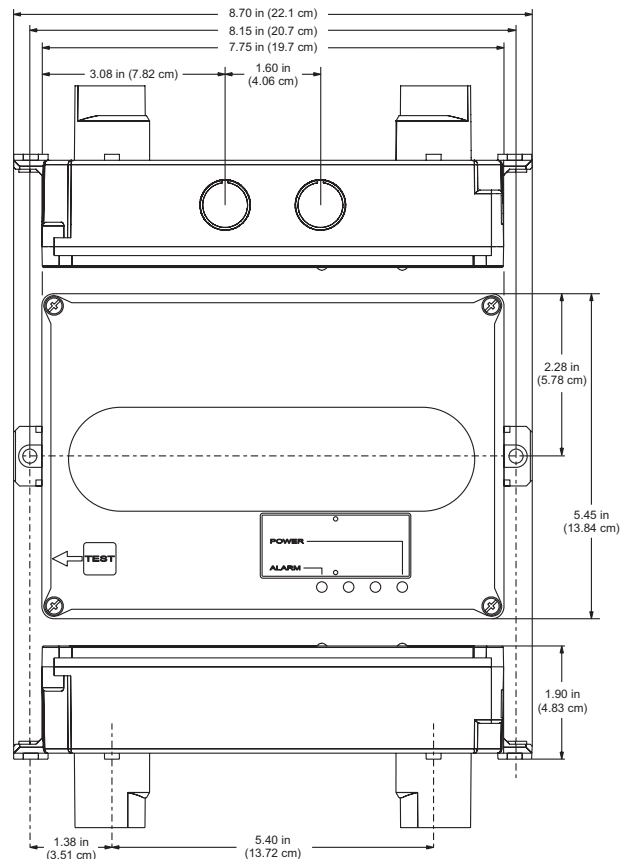

Assembly

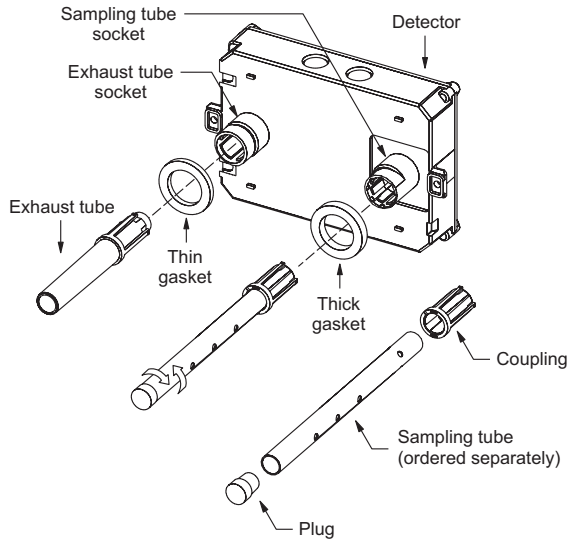

Mounting

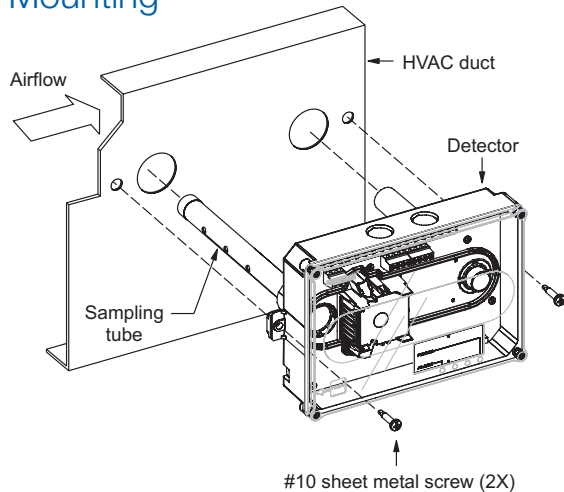

Wiring

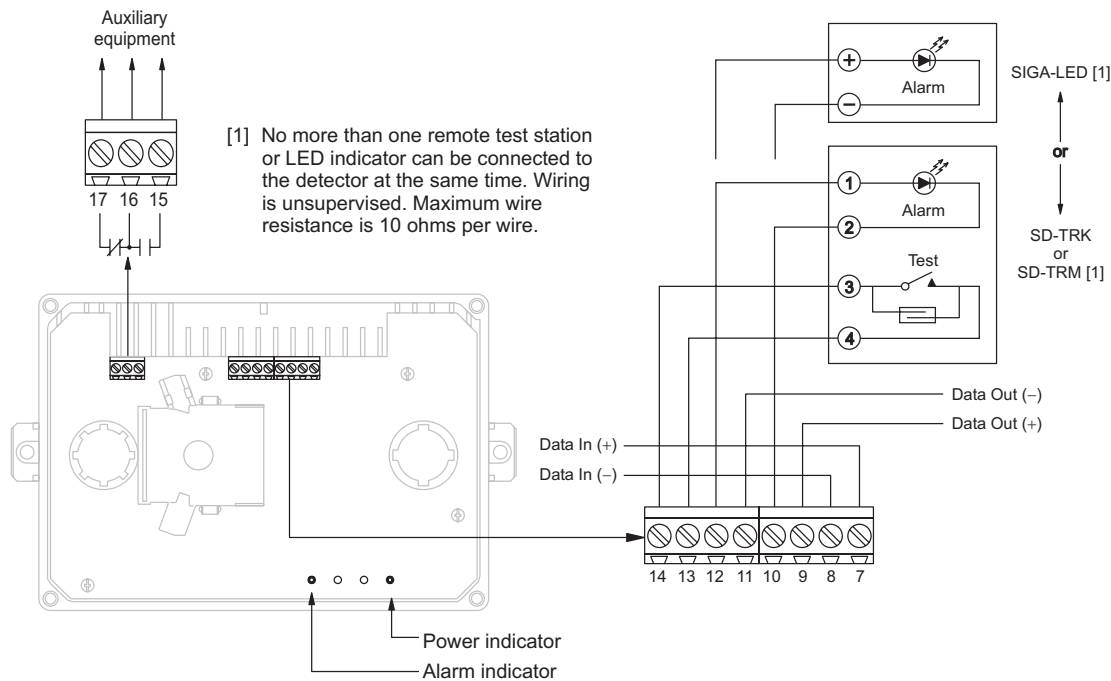

High-humidity environments

Use the SD-PH Protective Housing when installing SuperDuct detectors in high-humidity environments. The SD-PH is a weatherized housing that prevents condensation on the device by insulating the detectors and providing circulated air from the monitored HVAC duct. The SD-PH also adds a layer of protection against physical damage to the unit.

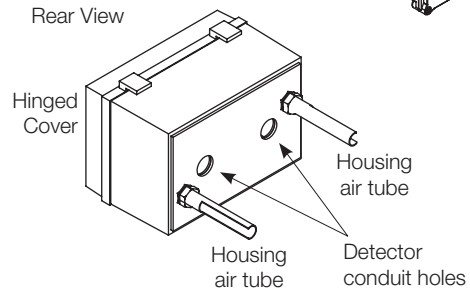
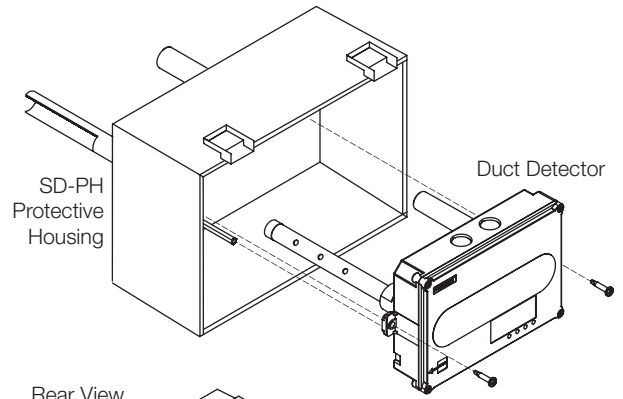

The SD-PH is easy to install and service. The hinged and transparent cover provides ready access to the detector, while keeping its status indicators visible at all times.

Note: The SD-PH Protective Housing is weatherized against outdoor air, but it is not intended for direct outdoor exposure.



Detection & alarm since 1872

U.S.
 T 888 378 2329
 F 866 503 3996

Canada
 Chubb Edwards
 T 519 376 2430
 F 519 376 7258

Southeast Asia
 T : +65 6391 9300
 F : +65 6391 9306

India
 T : +91 80 4344 2000
 F : +91 80 4344 2050

Australia
 T +61 3 9239 1200
 F +61 3 9239 1299

Europe
 T +32 2 725 11 20
 F +32 2 721 86 13

Latin America
 T 305 593 4301
 F 305 593 4300

utcfireandsecurity.com

© 2010 UTC Fire & Security.
 All rights reserved.

Specifications, detector

Dimensions	8.70 x 5.45 x 1.90 inches (221 x 138 x 48 mm)
Wire size	14 to 22 AWG
Detection method	Photoelectric (light scattering principle)
Air velocity rating	100 to 4,000 ft/min and meets the required minimum air pressure differential
Air pressure differential	0.005 to 1.00 inches of water
Sensitivity	0.79 to 2.46 %/ft obscuration
Alarm test response time	5 seconds
LED indicators	Alarm (red), Power (green)
Common alarm relay	Unsupervised and power-limited Quantity: 1 Type: Form C Ratings: 2.0 A at 30 Vdc (resistive)
Operating voltage	15.2 to 19.95 Vdc
Operating current	Standby: 45 µA Alarm: 45 µA Inrush: 1 mA Standalone alarm: 18 mA
Operating environment	Temperature (UL): -4 to 158 °F (-29 to 70 °C). Temperature (ULC): -4 to 120 °F (-29 to 49 °C) Relative humidity: 10 to 93%, noncondensing
Agency listings	UL, ULC, CSFM, FM, MEA

Specifications, test stations

Remote Test/Reset Stations provide alarm test, trouble indication, and reset capability from a remote location. They include a one-gang plate, momentary SPST switch, red alarm LED, and terminal block. Magnetically-operated models (TRM) or key-operated models (TRK) are available.

Compatible electrical boxes	North American 1-gang box Standard 4-in square box, 1-1/2 inches deep, with 1-gang cover
LED indicators	Alarm (red)
LED type	Clear lens
Wire size	14 to 22 AWG
Resistance per wire	10 Ohms, max.
Current requirements	See controller specifications
LED circuit ratings	Voltage: 3 Vdc, max. Current: 30 mA, max.
Switch ratings (SD-TRK)	Voltage: 125 Vdc, max. Current: 4 A, max.
Switch ratings (SD-TRM)	Voltage: 200 Vdc, max. Current: 0.5 A, max.
Compatible detectors	SuperDuct conventional two-wire and Signature duct smoke detectors
Operating environment	-4°F to 158°F (-20°C to 70°C) Humidity: 93% RH, noncondensing
Storage temperature	-4 to 140 °F (-20 to 60 °C)
Agency listings	UL, ULC, MEA, CSFM

Ordering Information

Catalog Number	Description	Ship Wt., lb. (kg)
SIGA-SD	Intelligent SuperDuct Detector	2.4 (1.1)
Accessories		
SD-T8	8-inch sampling tube	0.5 (0.2)
SD-T18	18-inch sampling tube	1.5 (0.7)
SD-T24	24-inch sampling tube	2.7 (1.2)
SD-T36	36-inch sampling tube	3.0 (1.4)
SD-T42	42-inch sampling tube	3.5 (1.6)
SD-T60	60-inch sampling tube	5.8 (2.6)
SD-T78	78-inch sampling tube	7.5 (3.4)
SD-T120	120-inch sampling tube	11.5 (5.2)
SD-PH	Protective housing for high humidity environments	5.5 (2.5)
SIGA-LED	Remote alarm LED	1.0 (0.5)
SD-TRM	Remote test station, magnetic	1.0 (0.5)
SD-TRK	Remote test station, keyed	1.0 (0.5)
SD-VTK	Air velocity test kit (stoppers only, etc)	1.0 (0.5)
SD-GSK	Cover gasket kit	0.5 (0.2)
SD-MAG	Test magnet kit	0.5 (0.2)
SIGA-SDPCB	Replacement PCB/Signature sensor kit	1.0 (0.5)

**Click Here to Return to
 Bill of Material/Index**

[Click Here to Return to Bill of Material/Index](#)

Input Modules

SIGA-CT1, SIGA-CT1HT,
SIGA-CT2, SIGA-MCT2

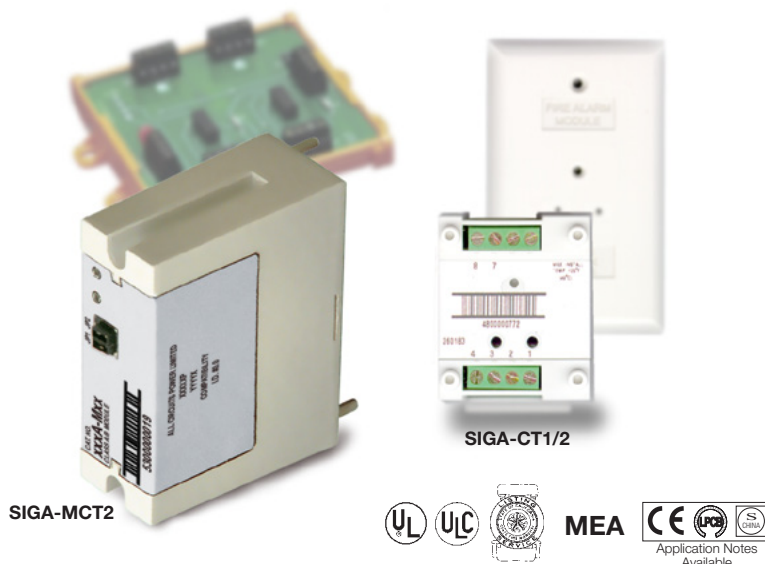

Overview

The SIGA-CT1 Single Input Module, SIGA-CT1HT High Temperature Single Input Module and SIGA-CT2/SIGA-MCT2 Dual Input Modules are intelligent analog addressable devices used to connect one or two Class B normally-open Alarm, Supervisory, or Monitor type dry contact Initiating Device Circuits (IDC).

The actual function of these modules is determined by the “personality code” selected by the installer. This code is downloaded to the module from the Signature loop controller during system configuration.

The input modules gather analog information from the initiating devices connected to them and convert it into digital signals. The module’s on-board microprocessor analyzes the signal and decides whether or not to input an alarm.

The SIGA-CT1, SIGA-CT1HT and SIGA-CT2 mount to standard North American 1-gang electrical boxes, making them ideal for locations where only one module is required. Separate I/O and data loop connections are made to each module.

The SIGA-CT1HT module operates at an expanded temperature range of 32 °F to 158 °F (0 °C to 70 °C) for those applications requiring more extreme environmental temperature variation.

The SIGA-MCT2 is part of the UIO family of plug-in Signature Series modules. It functions identically to the SIGA-CT2, but takes advantage of the modular flexibility and easy installation that characterizes all UIO modules. Two- and six-module UIO motherboards are available. All wiring connections are made to terminal blocks on the motherboard. UIO assemblies may be mounted in Edwards enclosures.

Standard Features

- **Multiple applications**
Including Alarm, Alarm with delayed latching (retard) for water-flow applications, Supervisory, and Monitor. The installer selects one of four “personality codes” to be downloaded to the module through the loop controller.
- **SIGA-CT1HT rated for high temperature environments**
Suitable for attic installation and monitoring high temperature heat detectors.
- **Plug-in (UIO) or standard 1-gang mount**
UIO versions allow quick installation where multiple modules are required. The 1-gang mount version is ideal for remote locations that require a single module.
- **Automatic device mapping**
Signature modules transmit information to the loop controller regarding their circuit locations with respect to other Signature devices on the wire loop.
- **Electronic addressing**
Programmable addresses are downloaded from the loop controller, a PC, or the SIGA-PRO Signature Program/Service Tool. There are no switches or dials to set.
- **Stand-alone operation**
The module makes decisions and inputs an alarm from initiating devices connected to it even if the loop controller’s polling interrogation stops. (Function availability dependent upon control panel.)
- **Ground fault detection by address**
Detects ground faults right down to the device level.

Signature Series Overview

The Signature Series intelligent analog-addressable system from Edwards Security is an entire family of multi-sensor detectors and mounting bases, multiple-function input and output modules, network and non-network control panels, and user-friendly maintenance and service tools. Analog information from equipment connected to Signature devices is gathered and converted into digital signals. An onboard microprocessor in each Signature device measures and analyzes the signal and decides whether or not to input an alarm. The microprocessor in each Signature device provides four additional benefits – Self-diagnostics and History Log, Automatic Device Mapping, Stand-alone Operation and Fast, Stable Communication.

Self-diagnostics and History Log – Each Signature Series device constantly runs self-checks to provide important maintenance information. The results of the self-check are automatically updated and permanently stored in its non-volatile memory. This information is accessible for review any time at the control panel, PC, or using the SIGA-PRO Signature Program/Service Tool.

Automatic Device Mapping –The Signature Data Controller (SDC) learns where each device's serial number address is installed relative to other devices on the circuit. The SDC keeps a map of all Signature Series devices connected to it. The Signature Series Data Entry Program also uses the mapping feature. With interactive menus and graphic support, the wired circuits between each device can be examined. Layout or "as-built" drawing information showing branch wiring (T-taps), device types and their address are stored on disk for printing hard copy.

Installation

SIGA-CT1, SIGA-CT1HT and SIGA-CT2: modules mount to North American 2½ inch (64 mm) deep 1-gang boxes and 1½ inch (38 mm) deep 4 inch square boxes with 1-gang covers and SIGA-MP mounting plates. The terminals are suited for #12 to #18 AWG (2.5 mm² to 0.75 mm²) wire size.

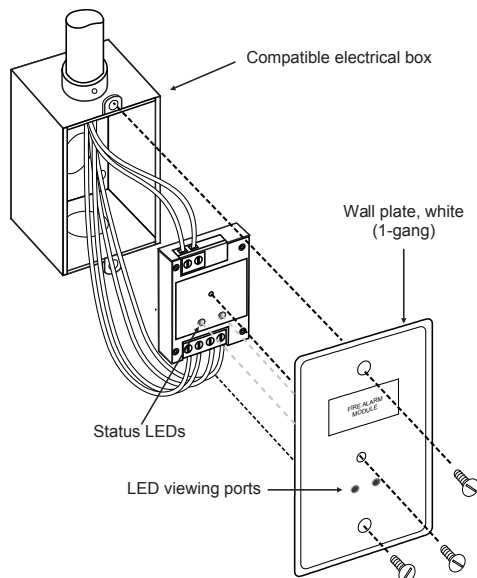

SIGA-MCT2: mount the UIO motherboard inside a suitable Edwards enclosure with screws and washers provided. Plug the SIGA-MCT2 into any available position on the motherboard and secure the module to the motherboard with the captive screws. Wiring connections are made to the terminals on the motherboard (see wiring diagram). UIO motherboard terminals are suited for #12 to #18 AWG (2.5 mm² to 0.75 mm²) wire size.

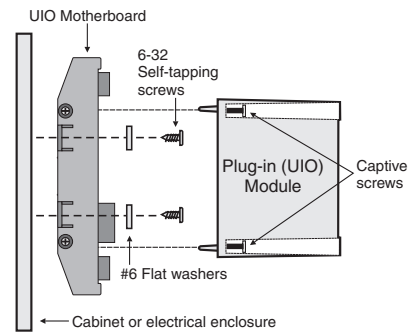

Electronic Addressing - The loop controller electronically addresses each module, saving valuable time during system commissioning. Setting complicated switches or dials is not required. Each module has its own unique serial number stored in its on-board memory. The loop controller identifies each device on the loop and assigns a "soft" address to each serial number. If desired, the modules can be addressed using the SIGA-PRO Signature Program/Service Tool.

Edwards recommends that this module be installed according to latest recognized edition of national and local fire alarm codes.

Application

The duty performed by the SIGA-CT1 and SIGA-CT2/MCT2 is determined by their sub-type code or "Personality Code". The code is selected by the installer depending upon the desired application and is downloaded from the loop controller.

One personality code can be assigned to the SIGA-CT1. Two personality codes can be assigned to the SIGA-CT2/MCT2. Codes 1, 2, 3 and 4 can be mixed on SIGA-CT2/MCT2 modules only. For example, personality code 1 can be assigned to the first address (circuit A) and code 4 can be assigned to the second address (circuit B).

NORMALLY-OPEN ALARM - LATCHING (Personality Code 1)

- Assign to one or both circuits. Configures either circuit A or B or both for Class B normally open dry contact initiating devices such as Pull Stations, Heat Detectors, etc. An ALARM signal is sent to the loop controller when the input contact is closed. The alarm condition is latched at the module.

NORMALLY-OPEN ALARM - DELAYED LATCHING (Personality Code 2)

- Assign to one or both circuits. Configures either circuit A or B or both for Class B normally-open dry contact initiating devices such as Waterflow Alarm Switches. An ALARM signal is sent to the loop controller when the input contact is closed for approximately 16 seconds. The alarm condition is latched at the module.

NORMALLY-OPEN ACTIVE - NON-LATCHING (Personality Code 3)

- Assign to one or both circuits. Configures either circuit A or B or both for Class B normally-open dry contact monitoring input such as from Fans, Dampers, Doors, etc. An ACTIVE signal is sent to the loop controller when the input contact is closed. The active condition is not latched at the module.

NORMALLY-OPEN ACTIVE - LATCHING (Personality Code 4)

- Assign to one or both circuits. Configures either circuit A or B or both for Class B normally open dry contact monitoring input such as from Supervisory and Tamper Switches. An ACTIVE signal is sent to the loop controller when the input contact is closed. The active condition is latched at the module.

Typical Wiring

Modules will accept #18 AWG (0.75mm²), #16 (1.0mm²), and #14AWG (1.50mm²), and #12 AWG (2.50mm²) wire sizes.

Note: Sizes #16 AWG (1.0mm²) and #18 AWG (0.75mm²) are preferred for ease of installation. See Signature Loop Controller catalog sheet for detailed wiring requirement specifications.

Initiating (Slave) Device Circuit Wire Specifications

Maximum Allowable Wire Resistance	50 ohms (25 ohms per wire) per Circuit	
Maximum Allowable Wire Capacitance	0.1µF per Circuit	
For Design Reference:	Wire Size	Maximum Distance to EOLR
	#18 AWG (0.75 mm ²)	4,000 ft (1,219 m)
	#16 AWG (1.00 mm ²)	
	#14 AWG (1.50 mm ²)	
	#12 AWG (1.50 mm ²)	

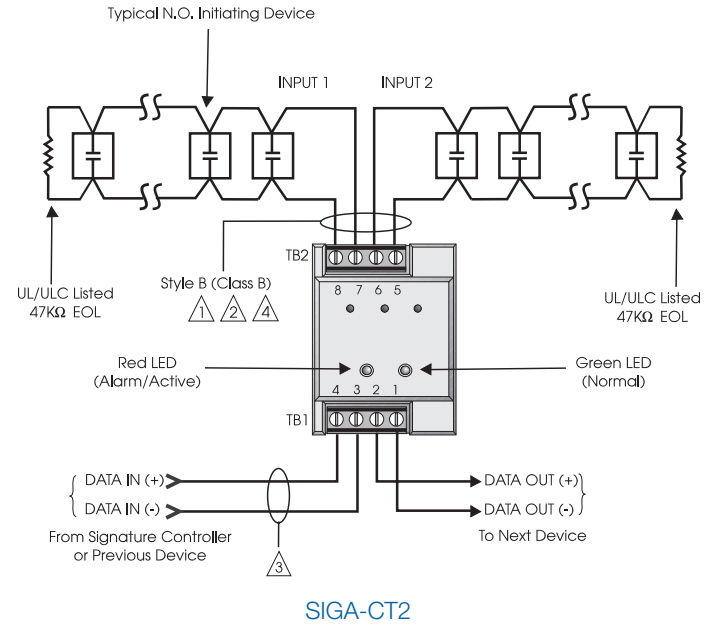
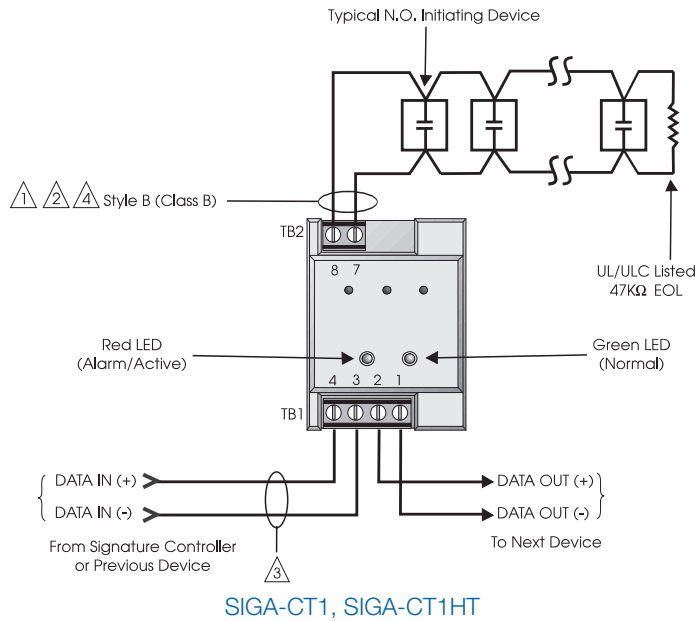

NOTES

- ① Maximum 25 Ohm resistance per wire.
- ② Maximum #12 AWG (2.5 mm²) wire; Minimum #18 AWG (0.75 mm²).
- ③ Refer to Signature controller installation sheet for wiring specifications.
- ④ Maximum 10 Vdc @ 350 µA
- ⑤ The SIGA-UIO6R and the SIGA-UIO2R do not come with TB14.
- 6 All wiring is supervised and power-limited.
- 7 These modules will not support 2-wire smoke detectors.

Warnings & Cautions

This module will not operate without electrical power. As fires frequently cause power interruption, we suggest you discuss further safeguards with your local fire protection specialist.

Compatibility

The Signature Series modules are compatible only with EST's Signature Loop Controller.

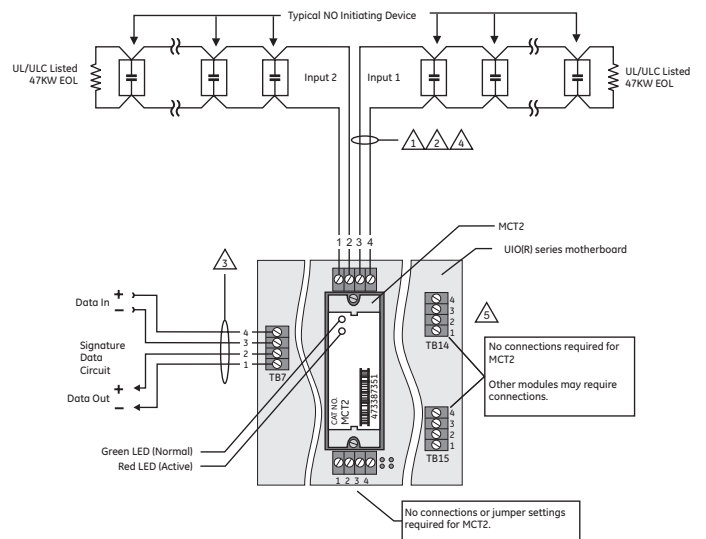



Detection & alarm since 1872

U.S.
T 888-378-2329
F 866-503-3996

Canada
Chubb Edwards
T 519 376 2430
F 519 376 7258

Southeast Asia
T : +65 6391 9300
F : +65 6391 9306

India
T : +91 80 4344 2000
F : +91 80 4344 2050

Australia
T +61 3 9239 1200
F +61 3 9239 1299

Europe
T +32 2 725 11 20
F +32 2 721 86 13

Latin America
T 305 593 4301
F 305 593 4300

utcfireandsecurity.com

© 2010 UTC Fire & Security.
All rights reserved.

Specifications

Catalog Number	SIGA-CT1HT	SIGA-CT1	SIGA-CT2	SIGA-MCT2
Description	Single Input Module		Dual Input Module	
Type Code	48 (factory set) Four sub-types (personality codes) are available		49 (factory set) Four sub-types (personality codes) are available	
Address Requirements	Uses One Module Address		Uses Two Module Addresses	
Operating Current	Standby = 250µA; Activated = 400µA		Standby = 396µA; Activated = 680µA	
Operating Voltage	15.2 to 19.95 Vdc (19 Vdc nominal)			
Construction	High Impact Engineering Polymer			
Mounting	North American 2½ inch (64 mm) deep one-gang boxes and 1½ inch (38 mm) deep 4 inch square boxes with one-gang covers and SIGA-MP mounting plates			UIO2R/6R/6 Motherboard
Operating Environment	32°F to 158°F (0°C to 70°C)	32°F to 120°F (0°C to 49°C)		
Storage Environment	-4°F to 140°F (-20°C to 60°C); Humidity: 0 to 93% RH			
LED Operation	On-board Green LED - Flashes when polled; On-board Red LED - Flashes when in alarm/active. Both LEDs - Glow steady when in alarm (stand-alone)			
Compatibility	Use with Signature Loop Controller			
Agency Listings	UL, ULC, MEA, CSFM			

Ordering Information

Catalog Number	Description	Ship Wt. lbs (kg)
SIGA-CT1	Single Input Module — UL/ULC Listed	0.4 (0.15)
SIGA-CT1HT	Single Input Module High Temperature Operation UL/ULC Listed	0.4 (0.15)
SIGA-CT2	Dual Input Module — UL/ULC Listed	0.4 (0.15)
SIGA-MCT2	Dual Input Plug-in (UIO) Module — UL, ULC Listed	0.1 (0.05)

Related Equipment		
27193-11	Surface Mount Box - Red, 1-gang	1.0 (0.6)
27193-16	Surface Mount Box - White, 1-gang	1.0 (0.6)
SIGA-UIO2R	Universal Input-Output Module Board w/Riser Inputs — Two Module Positions	0.32 (0.15)
SIGA-UIO6R	Universal Input-Output Module Board w/Riser Inputs — Six Module Positions	0.62 (0.28)
SIGA-UIO6	Universal Input-Output Module Board — Six Module Positions	0.56 (0.25)
MFC-A	Multifunction Fire Cabinet — Red, supports Signature Module Mounting Plates	7.0 (3.1)
SIGA-MB4	Transponder Mounting Bracket (allows for mounting two 1-gang modules in a 2-gang box)	0.4 (0.15)
SIGA-MP1	Signature Module Mounting Plate, 1 footprint	1.5 (0.70)
SIGA-MP2	Signature Module Mounting Plate, 1/2 footprint	0.5 (0.23)
SIGA-MP2L	Signature Module Mounting Plate, 1/2 extended footprint	1.02 (0.46)

[Click Here to Return to Bill of Material/Index](#)

[Click Here to Return to Bill of Material/Index](#)

Signal Modules

SIGA-CC1, SIGA-MCC1,
SIGA-CC2 & SIGA-MCC2

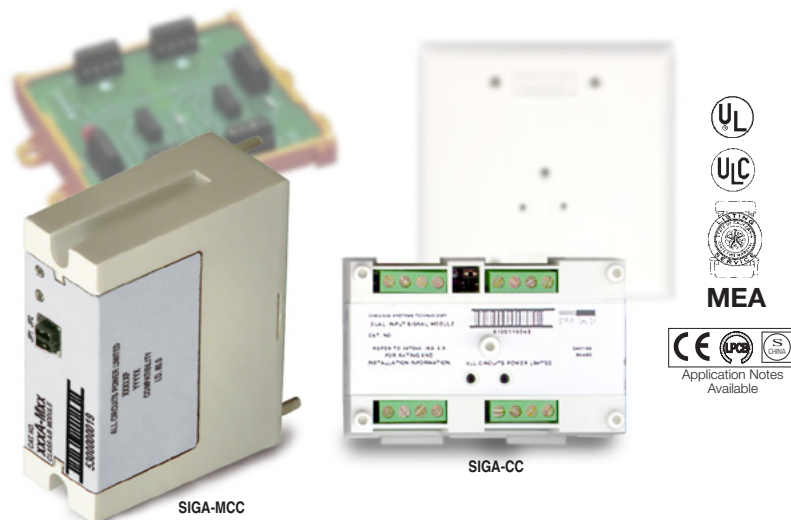

Overview

SIGA-CC1/MCC1 Single Input Signal Modules and SIGA-CC2/MCC2 Dual Input Signal Modules are part of EST's Signature Series system. They are intelligent analog addressable devices used for connecting, upon command from the loop controller, supervised Class B signal or telephone circuits to their respective power inputs. The power inputs may be polarized 24 Vdc to operate audible and visible signal appliances or 25 and 70 VRMS to operate audio evacuation speakers and firefighter's telephones.

The actual operation of the SIGA-CC1/MCC1 and SIGA-CC2/MCC2 is determined by the "personality code" selected by the installer. It is downloaded to the module from the Signature loop controller during system configuration.

The SIGA-CC1 and SIGA-CC2 mount to standard North American two-gang electrical boxes, making them ideal for locations where only one module is required. Separate I/O and data loop connections are made to each module.

The SIGA-MCC1 and SIGA-MCC2 are part of the UIO family of plug-in Signature Series modules. They function identically to the SIGA-CC1 and SIGA-CC2, but take advantage of the modular flexibility and easy installation that characterize all UIO modules. Two- and six-module UIO motherboards are available. These can accommodate individual risers for each on-board module, or risers that are shared by any combination of its UIO modules. All wiring connections are made to terminal blocks on the motherboard. UIO assemblies may be mounted in Edwards enclosures.

Standard Features

- Single and Dual input (riser) select**
 Use for connecting supervised 24 Vdc Audible/Visible signal circuits, or 25 and 70 VRMS Audio Evacuation and Telephone circuits to their power inputs.
- Ring-tone generator**
 When configured for telephone circuits, the SIGA-CC1 generates its own ring-tone signal eliminating the need for a separate ring-tone circuit.
- Plug-in (UIO) or standard 2-gang mount**
 UIO versions allow quick installation where multiple modules are required. The 2-gang mount version is ideal for remote locations that require a single module.
- Automatic device mapping**
 Signature modules transmit information to the loop controller regarding their circuit locations with respect to other Signature devices on the wire loop.
- Electronic addressing**
 Programmable addresses are downloaded from the loop controller, a PC, or the SIGA-PRO Signature Program/Service Tool; there are no switches or dials to set.
- Intelligent device with microprocessor**
 All decisions are made at the module to allow lower communication speed with substantially improved control panel response time and less sensitivity to line noise and loop wiring properties; twisted or shielded wire is not required.
- Ground fault detection by address**
 Detects ground faults right down to the device level.

Installation

The SIGA-CC1 and SIGA-CC2: mount to North American 2-1/2 inch (64 mm) deep two-gang boxes and 1-1/2 inch (38 mm) deep 4-inch square boxes with two-gang covers and SIGA-MP mounting plates. The terminals are suited for #12 to #18 AWG (2.5 mm² to 0.75 mm²) wire size.

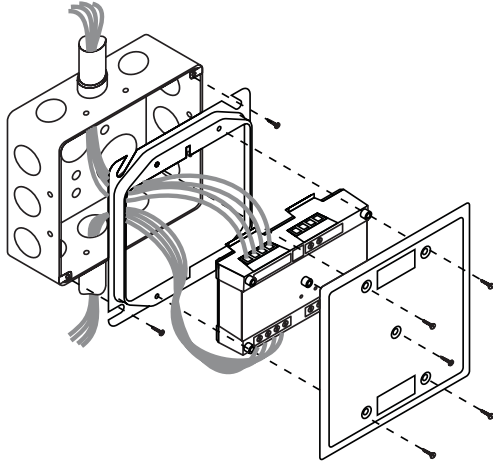

SIGA-MCC1 and SIGA-MCC2: mount the UIO motherboard inside a suitable Edwards enclosure with screws and washers provided. Plug the SIGA-MCC1 or SIGA-MCC2 into any available position on the motherboard and secure the module to the motherboard with the captive screws. Wiring connections are made to the terminals on the motherboard (see wiring diagram). UIO motherboard terminals are suited for #12 to #18 AWG (2.5 mm² to

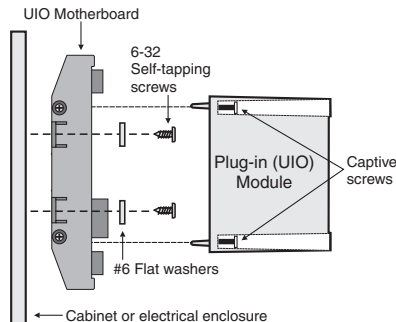

0.75 mm²) wire size.

Edwards recommends that this module be installed according to latest recognized edition of national and local fire alarm codes.

Electronic Addressing - The loop controller electronically addresses each module saving valuable time during system commissioning. Setting complicated switches or dials is not required. Each module has its own unique serial number stored in its on-board memory. The loop controller identifies each device on the loop and assigns a “soft” address to each serial number. If desired, the modules can be addressed using the SIGA-PRO Signature Program/Service Tool.

Personality Codes 5 and 6 apply to the SIGA-CC1/MCC1 only and are assigned by the installer. Code 7 applies to the SIGA-CC2/MCC2 only. It is factory assigned; no user configuration is required.

Application

The operation of the SIGA-CC1/MCC1 and SIGA-CC2/MCC2 is determined by their sub-type code or “Personality Code”. The code is selected by the installer depending upon the desired application and is down-loaded from the loop controller. Codes 5 and 6 apply to the SIGA-CC1/MCC1 only. Code 7 is assigned to the SIGA-CC2/MCC2 only and automatically applies to both circuits (A and B).

Personality Code 5: SIGNAL POWER or AUDIO EVACUATION (SINGLE RISER). Valid for the SIGA-CC1/MCC1 only. Configures the module for use as a Class B Audible/Visible Signal power (24 Vdc polarized) or Audio Evacuation (25 or 70 VRMS) power selector. The ring-tone generator is disabled. The output circuit is monitored for open or shorted wiring. If a short exists, the control panel inhibits the activation of the audible/visible signal circuit to prevent connection to the power circuit.

Personality Code 6: TELEPHONE w/RING-TONE (SINGLE RISER). Valid for the SIGA-CC1/MCC1 only. Configures the module for use as a Telephone power selector. When a telephone handset is plugged into its jack or lifted from its hook, the module generates its own Ring-Tone signal. A separate ring-tone circuit is not needed. The module sends this signal to the control panel to indicate that an off-hook condition is present. When the system operator responds to the call, the ring-tone signal is disabled.

Personality Code 7: SIGNAL POWER or AUDIO EVACUATION (DUAL RISER). Valid for the SIGA-CC2/MCC2 only. Configures the module for use as a two circuit Class B Audible/Visible Signal power (24 Vdc polarized) or Audio Evacuation (25 or 70 VRMS) power selector. The single output circuit is monitored for open or shorted wiring. If a short exists, the control panel inhibits the activation of the audible/visible signal circuit to prevent connection to the power circuit.

Warnings & Cautions

This module will not operate without electrical power. As fires frequently cause power interruption, we suggest you discuss further safeguards with your fire protection specialist.

Compatibility

The Signature Series modules are compatible only with EST's Signature Loop Controller.

Testing & Maintenance

The module's automatic self-diagnosis identifies when it is defective and causes a trouble message. The user-friendly maintenance program shows the current state of each module and other pertinent messages. Single modules may be turned off (de-activated) temporarily, from the control panel.

Scheduled maintenance (Regular or Selected) for proper system operation should be planned to meet the requirements of the Authority Having Jurisdiction (AHJ). Refer to current NFPA 72 and ULC CAN/ULC 536 standards.

Typical Wiring (SIGA-CC2/MCC2)

Modules will accept #18 AWG (0.75mm²), #16 (1.0mm²), #14 AWG (1.50mm²) and #12 AWG (2.5mm²) wire sizes.

Note: Sizes #16 AWG (1.0mm²) and #18 AWG (0.75mm²) are preferred for ease of installation. See Signature Loop Controller catalog sheet for detailed wiring requirement specifications.

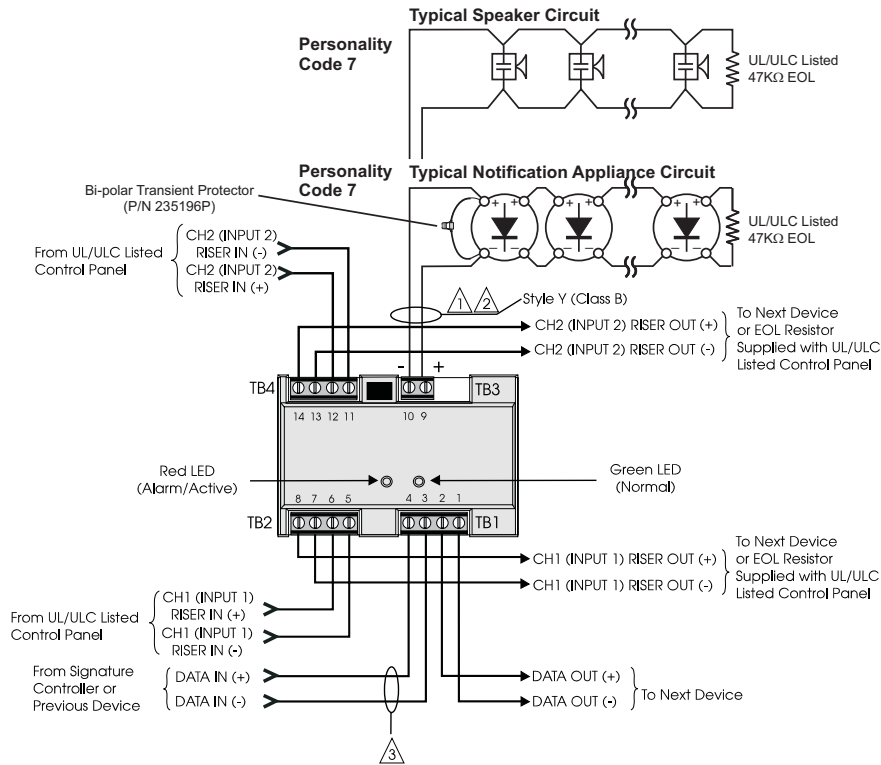

SIGA-CC2

Notes

- 1 For maximum wire resistance and maximum wire distances, refer to IOMC Manual (P/N 270144).
- 2 Maximum #12 AWG (2.5mm²) wire. Min. #18 (0.75mm²).
- 3 Refer to Signature Loop Controller Installation Sheet for wiring specifications.
- 4 These modules will NOT support two-wire smoke detectors.
- 5 All wiring power limited and supervised. If the input source is non-power limited, then maintain spacing of 1/4 inch or use FPL, FPLP, FPLR or equivalent in accordance with NEC.
- 6 The SIGA-UIO6 does not come with TB8 through TB13.
- 7 Supervised and power-limited.
- 8 Supervised and power-limited when connected to a power-limited source. If the source is nonpower-limited, maintain a space of 1/4 inch from power-limited wiring or use FPL, FPLP, FPLR, or an equivalent in accordance with the National Electrical Code.
- 9 The input for this riser is common to all modules.

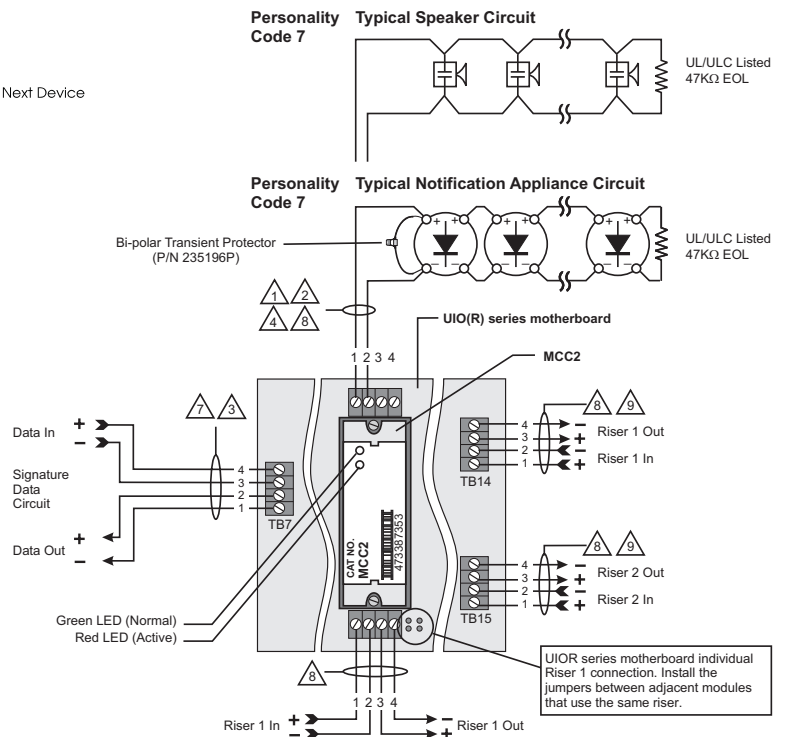

SIGA-MCC2

Maximum Output Load		
24Vdc	25V	70V
Signals	Audio	Audio
2A	50W	35W

Signature Series Overview

The Signature Series intelligent analog-addressable system from Edwards is an entire family of multi-sensor detectors and mounting bases, multiple-function input and output modules, network and non-network control panels, and user-friendly maintenance and service tools. Analog information from equipment connected to Signature devices is gathered and converted into digital signals. An onboard microprocessor in each Signature device measures and analyzes the signal and decides whether or not to input an alarm. The microprocessor in each Signature device provides four additional benefits – Self-diagnostics and History Log, Automatic Device Mapping, Stand-alone Operation and Fast, Stable Communication.

Self-diagnostics and History Log – Each Signature Series device constantly runs self-checks to provide important maintenance information. The results of the self-check are automatically updated and permanently stored in its non-volatile memory. This information is accessible for review any time at the control panel, PC, or using the SIGA-PRO Signature Program/Service Tool. The information stored in device memory includes:

- Device serial number, address, and type
- Time and date of last alarm (EST3 V 2 only.)
- Most recent trouble code logged by the detector — 32 possible trouble codes may be used to diagnose faults.

Automatic Device Mapping –The Signature Data Controller (SDC) learns where each device's serial number address is installed relative to other devices on the circuit. The SDC keeps a map of all Signature Series devices connected to it. The Signature Series Data Entry Program also uses the mapping feature. With interactive menus and graphic support, the wired circuits between each device can be examined. Layout or "as-built" drawing information showing branch wiring (T-taps), device types and their address are stored on disk for printing hard copy. This takes the mystery out of the installation. The preparation of as-built drawings is fast and efficient.

Device mapping allows the Signature Data Controller to discover:

- Unexpected additional device addresses
- Missing device addresses
- Changes to the wiring in the circuit.

Most Signature modules use a personality code selected by the installer to determine their actual function. Personality codes are downloaded from the SDC during system configuration and are indicated during device mapping.



Detection & alarm since 1872

U.S.
 T 888-378-2329
 F 866-503-3996

Canada
 Chubb Edwards
 T 519 376 2430
 F 519 376 7258

Southeast Asia
 T : +65 6391 9300
 F : +65 6391 9306

India
 T : +91 80 4344 2000
 F : +91 80 4344 2050

Australia
 T +61 3 9239 1200
 F +61 3 9239 1299

Europe
 T +32 2 725 11 20
 F +32 2 721 86 13

Latin America
 T 305 593 4301
 F 305 593 4300

utcfireandsecurity.com

© 2010 UTC Fire & Security.
 All rights reserved.

Specifications

Catalog Number	SIGA-CC1	SIGA-MCC1	SIGA-CC2	SIGA-MCC2
Description	Single Input (Riser) Signal Module		Dual Input (Riser) Signal Module	
Type Code	50 (factory set) Two sub-types (personality codes) are available		51 (factory set) One sub-type (personality code) is available (factory set)	
Address Requirements	Uses one module address		Uses two module addresses	
Wiring Terminations	Suitable for #12 to #18 AWG (2.5 mm ² to 0.75mm ²)			
Mounting	North American 2½ inch (64 mm) deep two-gang boxes and 1½ inch (38 mm) deep 4 inch square boxes with 2-gang covers and SIGA-MP mounting plates	Plugs into UIO2R, UIO6R or UIO6 Motherboards	North American 2½ inch (64 mm) deep two-gang boxes and 1½ inch (38 mm) deep 4 inch square boxes with 2-gang covers and SIGA-MP mounting plates	Plugs into UIO2R, UIO6R or UIO6 Motherboards
Operating Current	Standby = 223µA Activated = 100µA			
Operating Voltage	15.2 to 19.95 Vdc (19 Vdc nominal)			
Output Rating	24 Vdc = 2 amps 25 V Audio = 50 watts 70 V Audio = 35 watts			
Construction	High Impact Engineering Polymer			
Storage & Operating Environment	Operating Temperature: 32°F to 120°F (0°C to 49°C) Storage Temperature: -4°F to 140°F (-20°C to 60°C) Humidity: 0 to 93% RH			
LED Operation	On-board Green LED - Flashes when polled On-board Red LED - Flashes when in alarm/active			
Compatibility	Use with: Signature Loop Controller			
Agency Listings	UL, ULC, CSFM, MEA			

Ordering Information

Catalog Number	Description	Ship Wt. lbs (kg)
SIGA-CC1	Single Input Signal Module (Standard Mount) - UL/ULC Listed	0.5 (0.23)
SIGA-MCC1	Single Input Signal Module (UIO Mount) - UL/ULC Listed	0.18 (0.08)
SIGA-CC2	Dual Input Signal Module (Standard Mount) - UL/ULC Listed	0.5 (0.23)
SIGA-MCC2	Dual Input Signal Module (UIO Mount) - UL/ULC Listed	0.18 (0.08)

Related Equipment

27193-21	Surface Mount Box - Red, 2-gang	2 (1.2)
27193-26	Surface Mount Box - White, 2-gang	2 (1.2)
SIGA-UIO2R	Universal Input-Output Module Board w/Riser Inputs - Two Module Positions	0.32 (0.15)
SIGA-UIO6R	Universal Input-Output Module Board w/Riser Inputs - Six Module Positions	0.62 (0.28)
SIGA-UIO6	Universal Input-Output Module Board - Six Module Positions	0.56 (0.25)
235196P	Bi-polar Transient Protector	0.01 (0.05)

Accessories

MFC-A	Multifunction Fire Cabinet - Red, supports Signature Module Mounting Plates	7.0 (3.1)
SIGA-MP1	Signature Module Mounting Plate, 1 footprint	1.5 (0.70)
SIGA-MP2	Signature Module Mounting Plate, 1/2 footprint	0.5 (0.23)
SIGA-MP2L	Signature Module Mounting Plate, 1/2 extended footprint	1.02 (0.46)

[Click Here to Return to Bill of Material/Index](#)

Control Relay Modules

SIGA-CR, SIGA-MCR, SIGA-CRR, SIGA-MCRR



Overview

The Control Relay Module and the Polarity Reversal Relay Module are part of the Signature Series system. They are intelligent analog addressable devices available in either plug-in (UIO) versions, or standard 1-gang mount versions.

The SIGA-CR/MCR Control Relay Module provides a Form “C” dry relay contact to control external appliances such as door closers, fans, dampers etc. This device does not provide supervision of the state of the relay contact. Instead, the on-board micro-processor ensures that the relay is in the proper ON/OFF state. Upon command from the loop controller, the SIGA-CR/MCR relay activates the normally open or normally-closed contact.

The SIGA-CRR/MCRR Polarity Reversal Relay Module provides a Form “C” dry relay contact to power and activate a series of SIGA-AB4G Audible Sounder Bases. Upon command from the Signature loop controller, the SIGA-CRR reverses the polarity of its 24 Vdc output, thus activating all Sounder Bases on the data loop.

Standard-mount versions (SIGA-CR and SIGA-CRR) are installed to standard North American 1-gang electrical boxes, making them ideal for locations where only one module is required. Separate I/O and data loop connections are made to each module.

Plug-in UIO versions (SIGA-MCR and SIGA-MCRR) are part of the UIO family of plug-in Signature Series modules. They function identically to the standard mount versions, but take advantage of the modular flexibility and easy installation that characterizes all UIO modules. Two- and six-module UIO motherboards are available. All wiring connections are made to terminal blocks on the motherboard. UIO assemblies may be mounted in Edwards enclosures.

Standard Features

- **Provides one no/nc contact (SIGA-CR/MCR)**
Form “C” dry relay contact can be used to control external appliances such as door closers, fans, dampers etc.
- **Allows group operation of sounder bases**
The SIGA-CRR/MCRR reverses the polarity of its 24 Vdc output, thus activating all Sounder Bases on the data loop.
- **Plug-in (UIO) or standard 1-gang mount**
UIO versions allow quick installation where multiple modules are required. The 1-gang mount version is ideal for remote locations that require a single module.
- **Automatic device mapping**
Signature modules transmit information to the loop controller regarding their circuit locations with respect to other Signature devices on the wire loop.
- **Electronic addressing**
Programmable addresses are downloaded from the loop controller, a PC, or the SIGA-PRO Signature Program/Service Tool; there are no switches or dials to set.
- **Intelligent device with microprocessor**
All decisions are made at the module to allow lower communication speed with substantially improved control panel response time and less sensitivity to line noise and loop wiring properties; twisted or shielded wire is not required.
- **Ground fault detection by address**
Detects ground faults right down to the device level.

Installation

SIGA-CR and SIGA-CRR: modules mount to North American 2½ inch (64 mm) deep 1-gang boxes and 1½ inch (38 mm) deep 4 inch square boxes with 1-gang covers and SIGA-MP mounting plates. The terminals are suited for #12 to #18 AWG (2.5 mm² to 0.75 mm²) wire size.

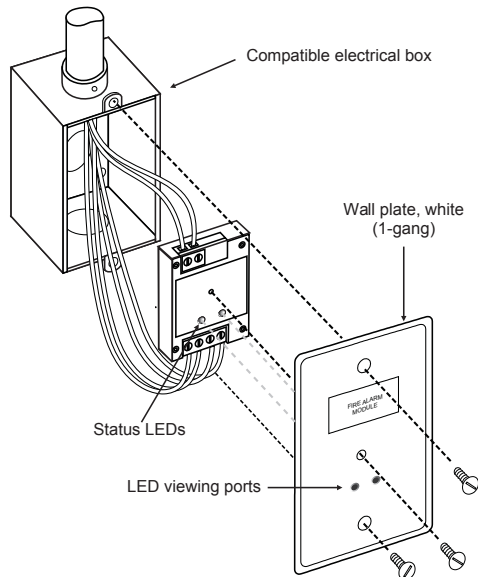

SIGA-MCR and SIGA-MCRR: mount the UIO motherboard inside a suitable Edwards enclosure with screws and washers provided. Plug the module into any available position on the motherboard and secure the module to the motherboard with the captive screws. Wiring connections are made to the terminals on the motherboard (see wiring diagram). UIO motherboard terminals are suited for #12 to #18 AWG (2.5 mm² to 0.75 mm²) wire size.

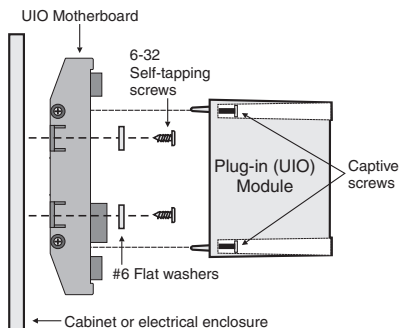

Electronic Addressing - The loop controller electronically addresses each module, saving valuable time during system commissioning. Setting complicated switches or dials is not required. Each module has its own unique serial number stored in its on-board memory. The loop controller identifies each device on the loop and assigns a “soft” address to each serial number. If desired, the modules can be addressed using the SIGA-PRO Signature Program/Service Tool.

Edwards recommends that this module be installed according to latest recognized edition of national and local fire alarm codes.

Application

The operation of Signature Series control relays is determined by their sub-type code or “Personality Code.”

Personality Code 8: CONTROL RELAY (SIGA-CR/MCR) - Dry Contact Output. This setting configures the module to provide one Form “C” DRY RELAY CONTACT to control Door Closers, Fans, Dampers, etc. Contact rating is 2.0 amp @ 24 Vdc; 0.5 amp @ 120 Vac (or 220 Vac for non-UL applications). Personality Code 8 is assigned at the factory. No user configuration is required.

Personality Code 8: POLARITY REVERSAL RELAY MODULE (SIGA-CRR/MCRR). This setting configures the module to reverse the polarity of its 24 Vdc output. Contact rating is 2.0 amp @ 24 Vdc (pilot duty). Personality Code 8 is assigned at the factory. No user configuration is required.

Compatibility

The Signature Series modules are compatible only with EST's Signature Loop Controller.

Warnings & Cautions

This module will not operate without electrical power. As fires frequently cause power interruption, we suggest you discuss further safeguards with your local fire protection specialist.

Testing & Maintenance

The module's automatic self-diagnosis identifies when it is defective and causes a trouble message. The user-friendly maintenance program shows the current state of each module and other pertinent messages. Single modules may be turned off (deactivated) temporarily, from the control panel. Availability of maintenance features is dependent on the fire alarm system used. Scheduled maintenance (Regular or Selected) for proper system operation should be planned to meet the requirements of the Authority Having Jurisdiction (AHJ). Refer to current NFPA 72 and ULC CAN/ULC 536 standards.

Typical Wiring

Modules will accept #18 AWG (0.75mm²), #16 (1.0mm²), #14 AWG (1.50mm²) and #12 AWG (2.5mm²) wire sizes.

Note: Sizes #16 AWG (1.0mm²) and #18 AWG (0.75mm²) are preferred for ease of installation. See Signature Loop Controller catalog sheet for detailed wiring requirement specifications.

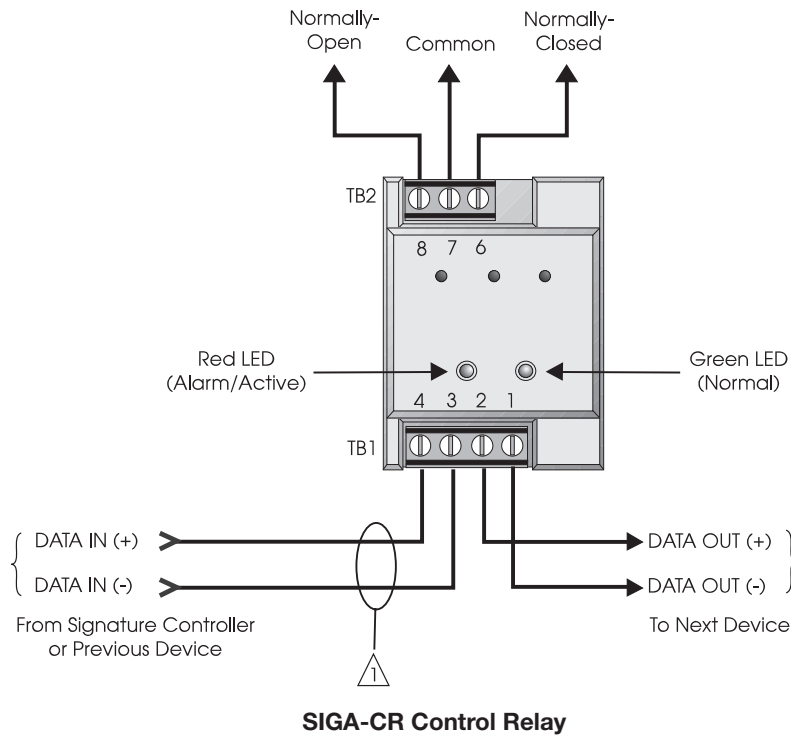

Notes

- 1) Refer to Signature Loop Controller Installation Sheet for wiring specifications.
- 2) NFPA 72 requires that the SIGA-CR/SIGA-MCR be installed in the same room as the device it is controlling. This requirement may not apply in all markets. Check with your local AHJ for details.
- 3) The SIGA-UIO6R and the SIGA-UIO2R do not come with TB14.
- 4) The SIGA-UIO6 does not come with TB8 through TB13.
- 5) Supervised and power-limited.
- 6) If the source is nonpower-limited, maintain a space of 1/4 inch from power-limited wiring or use FPL, FPLP, FPLR, or an equivalent in accordance with the National Electrical Code.
- 7) Maximum #12 AWG (2.5mm²) wire. Min. #18 (0.75mm²).

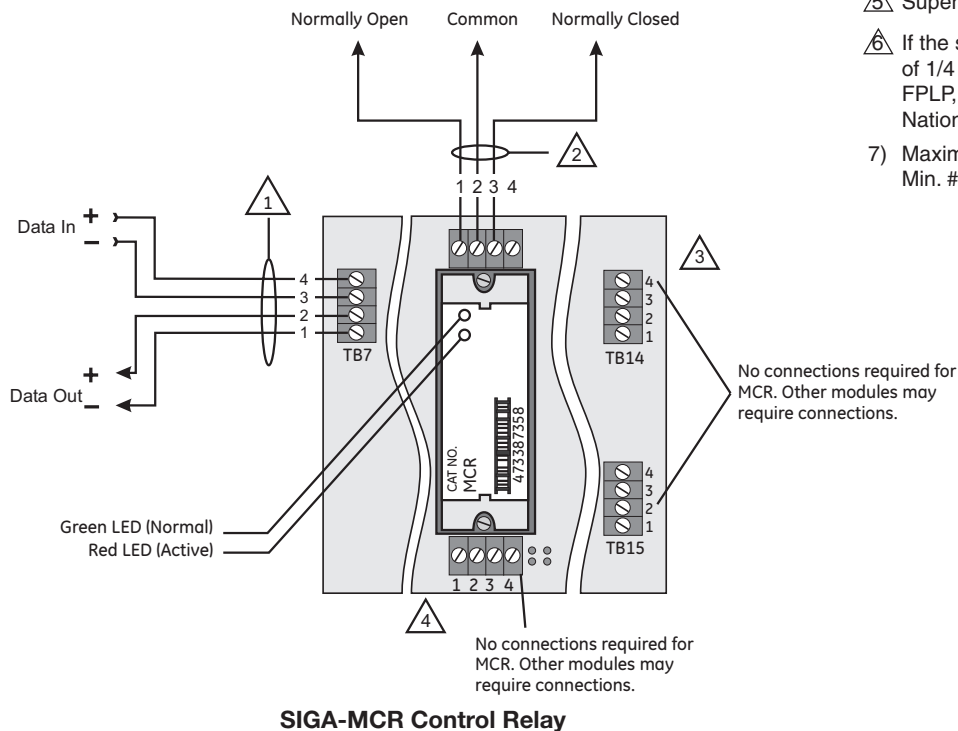

Typical Wiring

Modules will accept #18 AWG (0.75mm²), #16 (1.0mm²), #14 AWG (1.50mm²) and #12 AWG (2.50mm²) wire sizes.

Note: Sizes #16 AWG (1.0mm²) and #18 AWG (0.75mm²) are preferred for ease of installation. See Signature Loop Controller catalog sheet for detailed wiring requirement specifications.

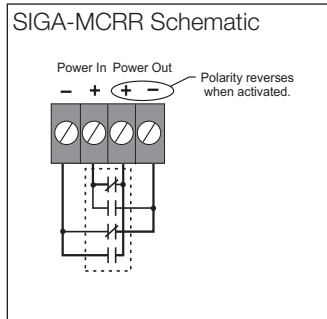
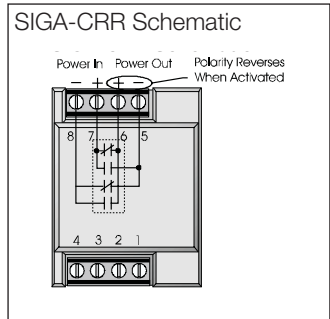
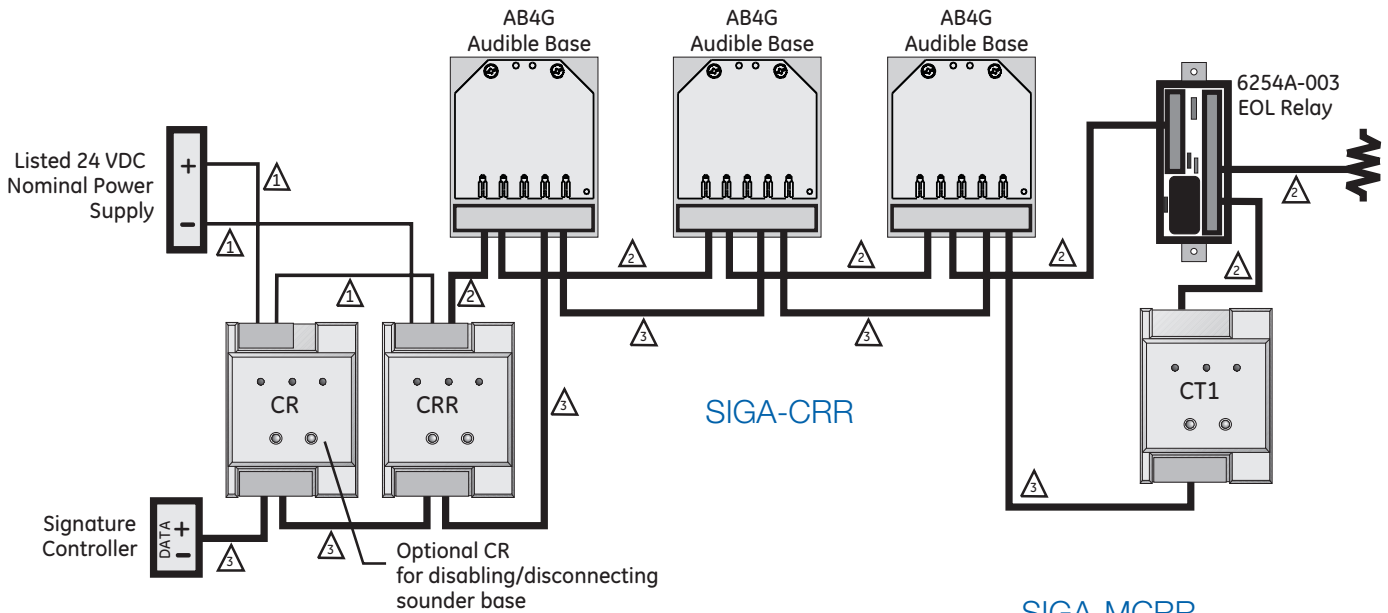

SIGA-MCRR

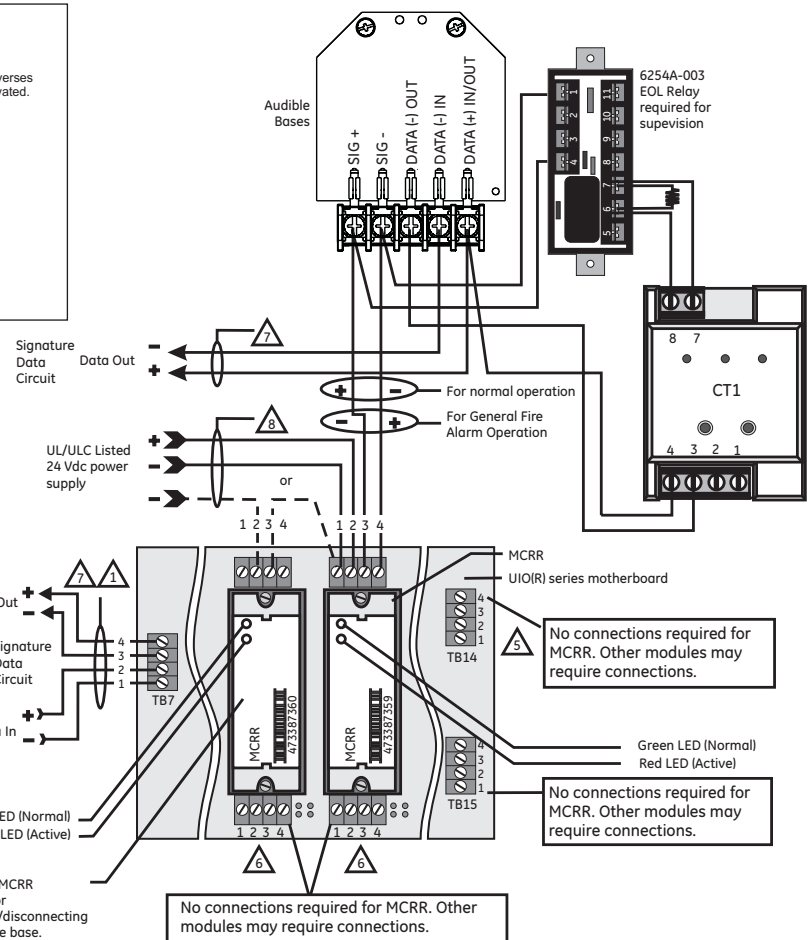

Notes

- ⚠ Refer to the Signature controller installation sheet for wiring.
- ⚡ One Pair of Wires (24 Vdc power).
- ⚡ One Pair of Wires (Signature Data).
- ⚡ Single Wire (24 Vdc power).
- ⚠ The SIGA-UIO6R and the SIGA-UIO2R do not come with TB14.
- ⚠ The SIGA-UIO6 does not come with TB8 through TB13.
- ⚠ Supervised and power-limited.
- 8 If the source is nonpower-limited, maintain a space of 1/4 inch from power-limited wiring or use FPL, FPLP, FPLR, or an equivalent in accordance with the National Electrical Code.
- 9 Maximum #12 AWG (2.5 mm²) wire; Minimum #18 AWG (0.75 mm²).
- 10 End-of-Line Relay must monitor and report power supply trouble to control panel.
- 11 Class B Data wiring may be "T-tapped."

Specifications

Catalog Number	SIGA-CR	SIGA-MCR	SIGA-CRR	SIGA-MCRR
Description	Control Relay		Polarity Reversal Relay	
Type Code	Personality Code 8 (Factory Set)		Personality Code 8 (Factory Set)	
Address Requirements	Uses 1 Module Address			
Operating Current	Standby = 100µA Activated = 100µA			
Operating Voltage	15.2 to 19.95 Vdc (19 Vdc nominal)			
Relay Type and Rating	Form "C" 24 VDC = 2 amps (pilot duty) 120 Vac = 0.5 amps 220 Vac (non-UL) = 0.5 amps			
Mounting	North American 2½ inch (64 mm) deep 1-gang boxes and 1½ inch (38 mm) deep 4 inch square boxes with 1-gang covers and SIGA-MP mounting plates	Plugs into UIO2R, UIO6R or UIO6 Motherboards	North American 2½ inch (64 mm) deep 1-gang boxes and 1½ inch (38 mm) deep 4 inch square boxes with 1-gang covers and SIGA-MP mounting plates	Plugs into UIO2R, UIO6R or UIO6 Motherboards
Construction & Finish	High Impact Engineering Polymer			
Storage and Operating Environment	Operating Temperature: 32°F to 120°F (0°C to 49°C) Storage Temperature: -4°F to 140°F (-20°C to 60°C) Humidity: 0 to 93% RH			
LED Operation	On-board Green LED - Flashes when polled On-board Red LED - Flashes when in alarm/active			
Compatibility	Use With: Signature Loop Controller			
Agency Listings	UL, ULC, CSFM, MEA			

Ordering Information

Catalog Number	Description	Ship Weight - lbs (kg)
SIGA-CR	Control Relay Module (Standard Mount)	0.4 (0.15)
SIGA-MCR	Control Relay Module (UIO Mount)	0.18 (0.08)
SIGA-CRR	Polarity Reversal Relay Module (Standard Mount)	0.4 (0.15)
SIGA-MCRR	Polarity Reversal Relay Module (UIO Mount)	0.18 (0.08)

Related Equipment		
27193-11	Surface Mount Box - Red, 1-gang	1 (0.6)
27193-16	Surface Mount Box - White, 1-gang	1 (0.6)
SIGA-UIO2R	Universal Input-Output Module Board w/Riser Inputs - Two Module Positions	0.32 (0.15)
SIGA-UIO6R	Universal Input-Output Module Board w/Riser Inputs - Six Module Positions	0.62 (0.28)
SIGA-UIO6	Universal Input-Output Module Board - Six Module Positions	0.56 (0.25)
SIGA-AB4G	Audible (Sounder) Detector Base	0.3 (0.15)

Accessories		
MFC-A	Multifunction Fire Cabinet - Red, supports Signature Module Mounting Plates	7.0 (3.1)
SIGA-MB4	Transponder Mounting Bracket (allows for mounting two 1-gang modules in a 2-gang box)	0.4 (0.15)
SIGA-MP1	Signature Module Mounting Plate, 1 footprint	1.5 (0.70)
SIGA-MP2	Signature Module Mounting Plate, 1/2 footprint	0.5 (0.23)
SIGA-MP2L	Signature Module Mounting Plate, 1/2 extended footprint	1.02 (0.46)



Detection & alarm since 1872

U.S.
T 888-378-2329
F 866-503-3996

Canada
Chubb Edwards
T 519 376 2430
F 519 376 7258

Southeast Asia
T : +65 6391 9300
F : +65 6391 9306

India
T : +91 80 4344 2000
F : +91 80 4344 2050

Australia
T +61 3 9239 1200
F +61 3 9239 1299

Europe
T +32 2 725 11 20
F +32 2 721 86 13

Latin America
T 305 593 4301
F 305 593 4300

utcfireandsecurity.com

© 2010 UTC Fire & Security.
All rights reserved.

Signature Series Overview

The Signature Series intelligent analog-addressable system from Edwards is an entire family of multi-sensor detectors and mounting bases, multiple-function input and output modules, network and non-network control panels, and user-friendly maintenance and service tools. Analog information from equipment connected to Signature devices is gathered and converted into digital signals. An onboard microprocessor in each Signature device measures and analyzes the signal and decides whether or not to input an alarm. The microprocessor in each Signature device provides four additional benefits – Self-diagnostics and History Log, Automatic Device Mapping, Stand-alone Operation and Fast, Stable Communication.

Self-diagnostics and History Log – Each Signature Series device constantly runs self-checks to provide important maintenance information. The results of the self-check are automatically updated and permanently stored in its non-volatile memory. This information is accessible for review any time at the control panel, PC, or using the SIGA-PRO Signature Program/Service Tool. The information stored in device memory includes:

- Device serial number, address, and type
- Time and date of last alarm
- Most recent trouble code logged by the detector — 32 possible trouble codes may be used to diagnose faults.

Automatic Device Mapping –The Signature Data Controller (SDC) learns where each device's serial number address is installed relative to other devices on the circuit. The SDC keeps a map of all Signature Series devices connected to it. The Signature Series Data Entry Program also uses the mapping feature. With interactive menus and graphic support, the wired circuits between each device can be examined. Layout or “as-built” drawing information showing branch wiring (T-taps), device types and their address are stored on disk for printing hard copy. This takes the mystery out of the installation. The preparation of as-built drawings is fast and efficient.

Device mapping allows the Signature Data Controller to discover:

- Unexpected additional device addresses
- Missing device addresses
- Changes to the wiring in the circuit.

Most Signature modules use a personality code selected by the installer to determine their actual function. Personality codes are downloaded from the SDC during system configuration and are indicated during device mapping.

Standalone Operation – A decentralized alarm decision by the device is guaranteed. Onboard intelligence permits the device to operate in standalone (degrade) mode. If Signature loop controller CPU communications fail for more than four seconds, all devices on that circuit go into standalone mode. The circuit acts like a conventional alarm receiving circuit. Each Signature device on the circuit continues to collect and analyze information from its slave devices. When connected to a panel utilizing standalone operation, modules with their “personality” set as alarm devices (IDC) will alarm should their slave alarm-initiating device activate.

[Click Here to Return to
Bill of Material/Index](#)

Field Configurable Horns and Strobes

Genesis Series

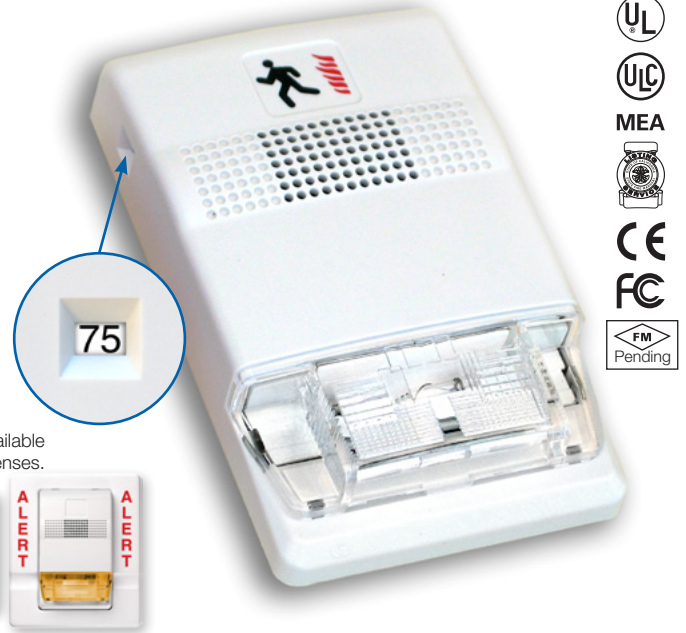

ECS/MNS appliances available with clear or amber lenses.



Overview

The Genesis line of fire alarm and mass notification/emergency communications (ECS/MNS) signals are among the smallest, most compact audible-visible life safety signaling devices in the world. About the size of a deck of playing cards, these devices are designed to blend with any decor.

Thanks to patented breakthrough technology, Edwards Genesis strobes do not require bulky specular reflectors and lenses. Instead, an exclusive cavity design conditions light to produce a highly controlled distribution pattern. Significant development efforts employing this new technology have given rise to a new benchmark in strobe performance – FullLight technology.

FullLight strobe technology produces a smooth light distribution pattern without the spikes and voids characteristic of specular reflectors. This ensures the entire coverage area receives consistent illumination from the strobe flash. As a result, Genesis strobes with FullLight technology go well beyond the UL-1971 and ULC-S526 light distribution requirements.

Genesis strobes and horn-strobes offer selectable candela output by means of a conveniently-located switch on the side of the device. Models are also available that offer fixed 15/75 cd output. The candela output setting remains clearly visible even after final installation, yet it stays locked in place to prevent unauthorized tampering.

Genesis ECS/MNS appliances offer emergency signaling with clear or amber lenses and with optional ALERT housing labels. They are ideal for applications that require differentiation between fire alarm and mass notification alerts.

Standard Features

- **Unique low-profile design**
 - The most compact UL-1971/ULC-S526 listed strobe available
 - Ultra-slim – protrudes less than one inch
 - Attractive appearance
 - No visible mounting screws
- **Four field-configurable options in one device**
 - Select 15, 30, 75, or 110 cd strobe output
 - Select high (default) or low dB horn output
 - Select temporal (default) or steady horn output
 - Select public mode flash rate (default) or private mode temporal flash
- **Fixed 15/75 cd model available**
- **ECS/MNS models available**
- **Easy to install**
 - Fits standard 1-gang electrical boxes – no trim plate needed
 - Optional trim plate accommodates oversized openings
 - Pre-assembled with captive hardware
 - #12 AWG terminals – ideal for long runs or existing wiring
- **Unparalleled performance**
 - Industry's most even light distribution
 - Meets tough synchronizing standards for strobes
 - Single microprocessor controls both horn and strobe
 - Independent horn control over a single pair of wires
 - Highly regulated in-rush current
 - Multiple frequency tone improves sound penetration
 - Field-programmable temporal strobe output option

Application

Genesis strobes are UL 1971-listed for use indoors as wall-mounted public-mode notification appliances for the hearing impaired. Prevailing codes require strobes to be used where ambient noise conditions exceed 105 dBA (87dBA in Canada), where occupants use hearing protection, and in areas of public accommodation as defined in the *Americans with Disabilities Act* (see *application notes – USA*).

Combination horn-strobe signals must be installed in accordance with guidelines established for strobe devices. Consult with your Authority Having Jurisdiction for details.

All Genesis strobes exceed UL synchronization requirements (within 10 milliseconds over a two-hour period) when used with a synchronization source. Synchronization is important in order to avoid epileptic sensitivity.

WARNING: These devices will not operate without electrical power. As fires frequently cause power interruptions, further safeguards such as backup power supplies may be required.

Horns

Genesis horn output reaches as high as 99 dB and features a unique multiple frequency tone that results in excellent sound penetration and an unmistakable warning of danger. Horns may be configured for either coded or non-coded signal circuits. They can also be set for low dB output with a jumper cut that reduces horn output by about 5 dB. Horn-only models may be ceiling-mounted or wall-mounted.

The suggested sound pressure level for each signaling zone used with alarm signals is at least 15 dB above the average ambient sound level, or 5 dB above the maximum sound level having a duration of at least 60 seconds, whichever is greater, measured 5 feet (1.5 m) above the floor. The average ambient sound level is, A-weighted sound pressure measured over a 24-hour period.

Doubling the distance from the signal to the ear will theoretically result in a 6 dB reduction of the received sound pressure level. The actual effect depends on the acoustic properties of materials in the space. A 3 dBA difference represents a barely noticeable change in volume.

ECS/MNS Applications

Genesis ECS/MNS strobe appliances bring the same high-performance fire alarm features and unobtrusive design to mass notification applications. Available with amber lenses and optional ALERT housing labels, they are ideal for applications that require differentiation between fire alarm and mass notification alerts.

Installation

Genesis horns and strobes mount to any standard one-gang surface or flush electrical box. Matching optional trim plates are used to cover oversized openings and can accommodate one-gang, two-gang, four-inch square, or octagonal boxes, and European 100 mm square.



Genesis Horn/Strobe with optional trim plate

All Genesis signals come pre-assembled with captive mounting screws for easy installation. Two tabs at the top of the signal unlock the cover to reveal the mounting hardware. The shallow depth of Genesis devices leaves ample room behind the signal for extra wiring. Once installed with the cover in place, no mounting screws are visible.

Field Configuration

Temporal horn and horn-strobe models are factory set to sound in a **three-pulse temporal pattern**. Units may be configured for use with coded systems by cutting a jumper on the circuit board. This results in a **steady output** that can be turned on and off (coded) as the system applies and removes power to the signal circuit. A Genesis Signal Master is required when horn-strobe models are configured for coded systems. Non-temporal, horn-only models sound a steady tone.

Genesis clear strobes and horn-strobes are shipped from the factory ready for use as **UL 1971 compliant** signals for public mode operation. These signals may be configured for **temporal flash** by cutting a jumper on the circuit board. This battery-saving feature is intended for private mode signaling only.

Genesis clear strobes and horn-strobes may be set for **15, 30, 75, or 110 candela output**. The output setting is changed by simply opening the device and sliding the switch to the desired setting. The device does not have to be removed to change the output setting. The setting remains visible through a small window on the side of the device after the cover is closed.

Horns and horn-strobes are factory set for **high dB output**. **Low dB output** may be selected by cutting a jumper on the circuit board. This reduces the output by about 5 dB.

Wiring

Field wiring terminals accommodate #18 to #12 AWG (0.75 mm² to 2.5 mm²) wiring. Horns, strobes, and combination horn-strobes are interconnected with a single pair of wires as shown below.

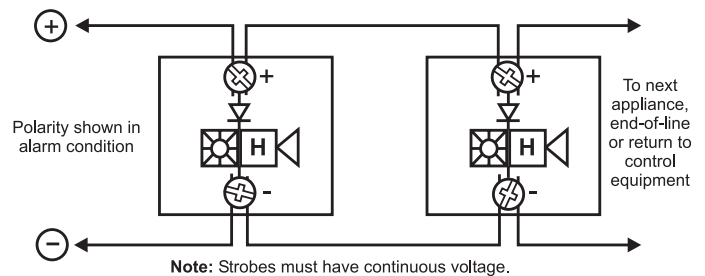

Current Draw

Strobes, Horn-Strobes

Multi-cd Wall Strobes (G1-VM)

UL Rating	15 cd* RMS	30 cd* RMS	15/75 cd** RMS	75 cd* RMS	110 cd* RMS
16 Vdc	103	141	152	255	311
16 Vfwr	125	179	224	346	392

*G1-VM multi-cd; **G1F-V1575 fixed 15/75 cd

Typical Current	15 cd RMS	30 cd RMS	15/75 RMS	75 cd RMS	110 cd RMS
16 Vdc	85	127	150	245	285
20 Vdc	71	98	123	188	240
24 Vdc	59	82	104	152	191
33 Vdc	46	64	84	112	137
16 Vfwr	119	169	223	332	376
20 Vfwr	103	143	189	253	331
24 Vfwr	94	129	169	218	262
33 Vfwr	87	112	148	179	205

Wall Temporal Horn-strobes – High dB Setting

UL Rating	15 cd* RMS	30 cd* RMS	15/75 cd** RMS	75 cd* RMS	110 cd* RMS	
16 Vdc	129	167	172	281	337	*G1-HDVM multi-cd
16 Vfwr	176	230	269	397	443	**G1F-HDV1575 fixed 15/75 cd

Typical Current	15 cd RMS	30 cd RMS	15/75 RMS	75 cd RMS	110 cd RMS
16 Vdc	102	135	160	246	309
20 Vdc	88	109	137	193	248
24 Vdc	81	94	122	161	203
33 Vdc	74	72	106	124	154
16 Vfwr	144	182	247	352	393
20 Vfwr	141	162	220	274	362
24 Vfwr	136	152	203	235	282
33 Vfwr	125	144	196	201	232

Wall Temporal Horn-strobes – Low dB Setting

UL Rating	15 cd* RMS	30 cd* RMS	15/75 cd** RMS	75 cd* RMS	110 cd* RMS	
16 Vdc	122	160	146	274	330	*G1-HDVM multi-cd
16 Vfwr	162	216	231	383	429	**G1F-HDV1575 fixed 15/75 cd

Typical Current	15 cd RMS	30 cd RMS	15/75 RMS	75 cd RMS	110 cd RMS
16 Vdc	96	130	158	243	302
20 Vdc	79	104	133	189	241
24 Vdc	68	88	119	156	197
33 Vdc	56	71	100	118	146
16 Vfwr	128	180	241	344	389
20 Vfwr	118	157	213	266	343
24 Vfwr	113	144	195	230	279
33 Vfwr	112	137	182	197	226

Horns

Wall or Ceiling Mounted Temporal Horns (G1-HD)

UL Rating	High dB (RMS)	Low dB (RMS)
16 Vdc	26	19
24 Vdc	36	27
33 Vdc	41	33
16 Vfwr	51	37
24 Vfwr	69	52
33 Vfwr	76	70

Typical Current	High dB RMS	Low dB RMS
16 Vdc	22	17
20 Vdc	24	19
24 Vdc	27	22
33 Vdc	32	26
16 Vfwr	34	30
20 Vfwr	40	34
24 Vfwr	45	38
33 Vfwr	52	47

Wall or Ceiling Mounted Horns (G1-P)

UL Designation	Voltage Range	Max. Current, RMS
Regulated 24 Vdc	16 - 33 Vdc	13 mA
24 fwr	16 - 33 Vfwr	11 mA

Typical Current	RMS
24 Vdc	10
24 Vdc	11
31 Vdc	12
20 Vfwr	9
24 Vfwr	10

Current values are shown in mA.

dBA output

Temporal Horns, Horn-strobes (G1-HD, G1-HDVM series)

High dB Setting	UL464		Average	Peak
	Temporal	Steady	Temporal/Steady	Temporal/Steady
16 Vdc	81.4	85.5	91.4	94.2
24 Vdc	84.4	88.6	94.5	97.6
33 Vdc	86.3	90.4	96.9	99.5

Low dB Setting	UL464		Average	Peak
	Temporal	Steady	Temporal/Steady	Temporal/Steady
16 Vdc	76.0	80.1	86.3	89.2
24 Vdc	79.4	83.5	89.8	92.5
33 Vdc	82.1	86.5	92.5	95.3

Steady Tone Horns (G1-P series)

	UL464	Average	Peak
16 Vdc	77 dBA, min	85 dBA	91 dBA
16 Vfwr	77 dBA, min	85 dBA	91 dBA

Notes

1. All values shown are dBA measured at 10 feet (3.01m).
2. UL464 values measured in reverberant room.
3. Average and Peak values are measured in anechoic chamber.

Average Sound Output (dBA)

(High dB setting, anechoic, 24V, measured at 10ft)

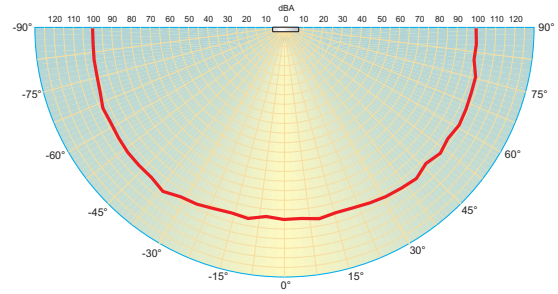

Light output - (effective cd)

Percent of UL rating versus angle

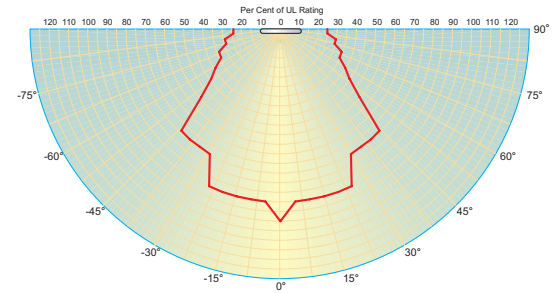

Specifications

Housing	Red or white textured UV stabilized, color impregnated engineered plastic. Exceeds 94V-0 UL flammability rating.
Lens	Optical grade polycarbonate (clear)
Mounting (indoor only)	Strobes and horn-strobes are for wall-mount installation only. Horn-only models may be ceiling- or wall-mounted. Flush mount: 2½ inch (64 mm) deep one-gang box Surface mount: Model 27193 surface mount box, wiremold box, or equivalent surface-mount box With optional trim plate: One-gang, two-gang, four-inch square, octagonal, or European single-gang box
Wire connections	Screw terminals: single input for both horn and strobe. #18 to #12 AWG (0.75 mm ² to 2.5 mm ²) wire size
Operating environment	Indoor only: 32-120°F (0-49°C) ambient temperature. 93% relative humidity
Agency listings/approvals	UL 1971, UL 1638, UL 464, ULC S525, ULC S526, CSFM, CE, FCC, MEA. (All models comply with ADA Code of Federal Regulation Chapter 28 Part 36 Final Rule.)
Dimensions (HxWxD)	Signal: 4-1/2" x 2-3/4" x 13/16" (113 mm x 68 mm x 21 mm) Trimplate: 5" (127 mm); Height – 5-7/8" (149 mm); Depth – ½" (13 mm)
Operating voltage	G1-HD series temporal-tone horns: non-coded, filtered 16-33 Vdc or unfiltered 16-33 Vdc FWR (or coded when horn set to steady tone) G1-HDVM series temporal-tone horn-strobes: non-coded, filtered 16-33 Vdc or unfiltered 16-33 Vdc FWR (or coded (audible NAC only) when used with optional G1M Genesis Signal Master) G1-VM series strobes: non-coded, filtered 16 - 33 Vdc or unfiltered 16-33 Vdc FWR G1-P series steady-tone horns: coded or non-coded, filtered 20-31 Vdc or unfiltered 20-27 Vfwr
Strobe output rating	UL 1971, UL 1638, ULC S526: selectable 15 cd, 30 cd, 75 cd, or 110 cd output UL 1971: 15 cd (fixed 15/75 cd models) UL 1638, ULCS526: 75 cd (fixed 15/75 cd models)
Strobe flash rate	G1-VM strobes and G1-HDVM series temporal-tone horn-strobes: one flash per second synchronized with optional G1M Genesis Signal Master indefinitely within 10 milliseconds. Temporal setting (private mode only): synchronized to temporal output of horns on same circuit
Synchronization Sources	SIGA-CC1S, SIGA-MCC1S, SIGA-CC2A, SIGA-MCC2A, G1M-RM BPS6A, BPS10A, APS6A, APS10A, iO64, iO500, Firesield Plus 3, 5 and 10 zone. Add G1M for G1-CVM & G1-HDVM devices only.
Horn pulse rate	G1-HD temporal-tone horns and G1-HDVM series temporal-tone horn-strobes: temporal rate synchronized with optional G1M Genesis Signal Master indefinitely within 10 milliseconds. G1-P steady-tone horns: continuous, steady tone only
Temporal audible pattern	½ sec ON, ½ sec OFF, ½ sec ON, ½ sec OFF, ½ sec ON, 1½ sec OFF, then repeat cycle

Candela Output

Lens Color	Rating	Switch Position A	Switch Position B	Switch Position C	Switch Position D
Amber	UL 1638	110 cd	75 cd	30 cd	15 cd
Amber	UL 1971*	88 cd	60 cd	24 cd	12 cd
Clear	UL 1971	110 cd	75 cd	30 cd	15 cd

* Equivalent Rating

Fire appliances available with white or red housings.



ECS/MNS appliances available with clear or amber lenses.



Ordering Information

Model	Housing	Marking	Lens	Strobe	Horn	Ship Wt. lbs (kg)
-------	---------	---------	------	--------	------	-------------------

Fire Alarm Appliances (c/w running man icon screen printed on housing)

G1-VM	White	None	Clear	Selectable 15, 30, 75, or 110 cd	Strobe only	0.25 (0.11)
G1F-HD	White	FIRE	Clear	Horn only	Selectable high/low dB	0.25 (0.11)
G1F-HDV1575	White	FIRE	Clear	15/75 cd ¹	Temporal hi/lo dB-24V	0.25 (0.11)
G1F-HDVM	White	FIRE	Clear	Selectable 15, 30, 75, or 110 cd	Selectable high/low dB	0.25 (0.11)
G1F-P	White	FIRE	Clear	Steady Horn (not compatible with Genesis Signal Master)		0.25 (0.11)
G1F-V1575	White	FIRE	Clear	15/75 cd ¹	Strobe only	0.25 (0.11)
G1F-VM	White	FIRE	Clear	Selectable 15, 30, 75, or 110 cd	Strobe only	0.25 (0.11)
G1-HD	White	None	Clear	Horn only	Selectable high/low dB	0.25 (0.11)
G1-HDVM	White	None	Clear	Selectable 15, 30, 75, or 110 cd	Selectable high/low dB	0.25 (0.11)
G1-P	White	None	Clear	Steady Horn (not compatible with Genesis Signal Master)		0.25 (0.11)
G1RF-HD	Red	FIRE	Clear	Horn only	Selectable high/low dB	0.25 (0.11)
G1RF-HDV1575	Red	FIRE	Clear	15/75 cd ¹	Temporal hi/lo dB-24V	0.25 (0.11)
G1RF-HDVM	Red	FIRE	Clear	Selectable 15, 30, 75, or 110 cd	Selectable high/low dB	0.25 (0.11)
G1RF-P	Red	FIRE	Clear	Steady Horn (not compatible with Genesis Signal Master)		0.25 (0.11)
G1RF-V1575	Red	FIRE	Clear	15/75 cd ¹	Strobe only	0.25 (0.11)
G1RF-VM	Red	FIRE	Clear	Selectable 15, 30, 75, or 110 cd	Strobe only	0.25 (0.11)
G1R-HD	Red	None	Clear	Horn only	Selectable high/low dB	0.25 (0.11)
G1R-HDVM	Red	None	Clear	Selectable 15, 30, 75, or 110 cd	Selectable high/low dB	0.25 (0.11)
G1R-P	Red	None	Clear	Steady Horn (not compatible with Genesis Signal Master)		0.25 (0.11)
G1R-VM	Red	None	Clear	Selectable 15, 30, 75, or 110 cd	Strobe only	0.25 (0.11)

ECS/MNS Appliances (no running man icon on housing)

G1WA-VMA	White	ALERT	Amber	Selectable A, B, C or D	Strobe only	0.25 (0.11)
G1WA-VMC	White	ALERT	Clear	Selectable 15, 30, 75, or 110 cd	Strobe only	0.25 (0.11)
G1WN-VMA	White	None	Amber	Selectable A, B, C or D	Strobe only	0.25 (0.11)
G1WN-VMC	White	None	Clear	Selectable 15, 30, 75, or 110 cd	Strobe only	0.25 (0.11)

Trim Plates

G1T	White	None	Genesis Trim Plate (for two-gang or 4" square boxes)			0.15 (0.7)
G1RT	Red	None	Genesis Trim Plate (for two-gang or 4" square boxes)			0.15 (0.7)
G1T-FIRE	White	FIRE	Genesis Trim Plate (for two-gang or 4" square boxes)			0.15 (0.7)
G1RT-FIRE	Red	FIRE	Genesis Trim Plate (for two-gang or 4" square boxes)			0.15 (0.7)
G1WT-ALERT	White	ALERT	Genesis Trim Plate (for two-gang or 4" square boxes)			0.15 (0.7)

Surface Boxes

27193-16	White	N/A	One-gang surface mount box			1 (0.4)
27193-11	Red	N/A	One-gang surface mount box			1 (0.4)

¹ These 15/75 cd models provide fixed output and are not multi-candela devices. The 15 cd output component complies with UL1971, while the 75 cd output component complies with UL 1638.



Detection & alarm since 1872

U.S.
T 888 378 2329
F 866 503 3996

Canada
Chubb Edwards
T 519 376 2430
F 519 376 7258

Southeast Asia
T : +65 6391 9300
F : +65 6391 9306

India
T : +91 80 4344 2000
F : +91 80 4344 2050

Australia
T +61 3 9239 1200
F +61 3 9239 1299

Europe
T +32 2 725 11 20
F +32 2 721 86 13

Latin America
T 305 593 4301
F 305 593 4300

utcfireandsecurity.com

© 2010 UTC Fire & Security.
All rights reserved.

[Click Here to Return to
Bill of Material/Index](#)

Remote Booster Power Supplies

BPS6A, BPS10A

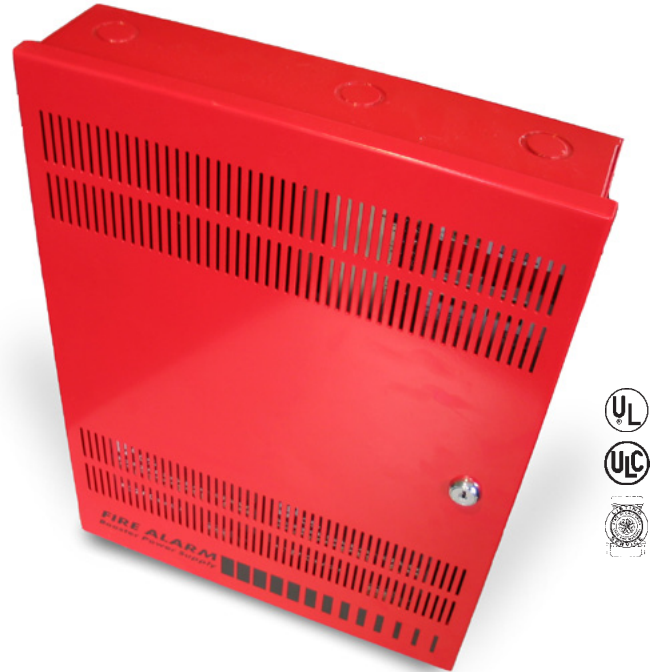

Overview

The Booster Power Supply (BPS) is a UL 864, 9th Edition listed power supply. It is a 24 Vdc filtered-regulated, and supervised unit that can easily be configured to provide additional notification appliance circuits (NACs) or auxiliary power for Mass Notification/Emergency Communication (MNEC), as well as life safety, security, and access control applications.

The BPS contains the circuitry to monitor and charge internal or external batteries. Its steel enclosure has room for up to two 10 ampere-hour batteries. For access control-only applications, the BPS can support batteries totaling up to 65 ampere-hours in an external enclosure. The BPS has four Class B (convertible to two Class A) NACs. These can be activated in one or two groups from the BPS's unique dual input circuits.

The BPS is available in 6.5 or 10 ampere models. Each output circuit has a capacity of three amperes; total current draw cannot exceed the unit's rating.

The BPS meets current UL requirements and is listed under the following standards:

Standard (CCN)	Description
UL864 9th ed.ition (UOXX)	Fire Alarm Systems
UL636 (ANET, UEHX7)	Holdup Alarm Units and Systems
UL609 (AOTX, AOTX7)	Local Burglar Alarm Units and Systems
UL294 (ALVY, UEHX7)	Access Control Systems
UL365 (APAW, APAW7)	Police Station Connected Burglar Alarm Units and Systems
UL1076 (APOU, APOU7)	Proprietary Burglar Alarm System Units
UL1610 (AMCX)	Central Station Alarm Unit
ULC-S527 (UOXXC)	Control Units, Fire Alarm (Canada)
ULC-S303 (AOTX7)	Local Burglar Alarm Units and Systems (Canada)
C22.2 No. 205	Signaling Equipment (Canada)

Standard Features

- Allows for reliable filtered and regulated power to be installed where needed
- Cost effective system expansion
- Provides for Genesis and Enhanced Integrity notification appliance synchronization
- Supports coded output operation
- Self-restoring overcurrent protection
- Multiple signal rates
- Can be cascaded or controlled independently
- Easy field configuration
- On-board diagnostic LEDs identify wiring or internal faults
- Standard Edwards keyed lockable steel cabinet with removable door
- 110 and 230 Vac models available
- Accommodates 18 to 12 AWG wire sizes
- Optional tamper switch
- Dual battery charging rates
- Optional earthquake hardening; OSHPD seismic pre-approval for component Importance Factor 1.5

Application

The BPS provides additional power and circuits for notification appliances and other 24 Vdc loads. It is listed for indoor dry locations and can easily be installed where needed.

Fault conditions are indicated on the on-board diagnostic LEDs, opening the BPS input sense circuit and the trouble relay (if programmed). While this provides indication to the host system, the BPS can still be activated upon command. A separate AC Fail contact is available on the BPS circuit board, which can be programmed for trouble or AC Fail. There are seven on-board diagnostic LEDs: one for each NAC fault, one for battery fault, one for ground fault, and one for AC power.

The unique dual-input activation circuits of the BPS can be activated by any voltage from 6 to 45 VDC (filtered-regulated) or 11 to 33 Vdc (full-wave rectified, unfiltered). The first input circuit can be configured to activate 1-4 of the four possible outputs. The second input circuit can be configured to control circuits 3 and 4. When outputs are configured for auxiliary operation, these circuits can be configured to stay on or automatically deactivate 30 seconds after AC power is lost. This feature makes these circuits ideal for door holder applications. The BPS also has a separate 200 mA 24 Vdc output that can be used to power internal activation modules.

BPS NACs can be configured for a 3-3-3 temporal or continuous output. California temporal rate outputs are also available on certain models. This makes the BPS ideal for applications requiring signaling rates that are not available from the main system.

In addition to the internally generated signal rates, the BPS can also be configured to follow the coded signal rate of the main system NACs. This allows for the seamless expansion of existing NACs.

The BPS enclosure has mounting brackets for up to three Signature modules to the right of the circuit board.

Engineering Specification

Supply, where needed, Edwards BPS Series Booster Power Supplies (BPS) that are interconnected to and supervised by the main system. The BPS shall function as a stand-alone auxiliary power supply with its own fully-supervised battery compliment. The BPS battery compliment shall be sized to match the requirements of the main system. The BPS shall be capable of supervising and charging batteries having the capacity of 24 ampere-hours for Mass Notification/Emergency Communication (MNEC), life safety and security applications, and the capacity of 65 ampere-hours for access control applications.

<<The BPS shall be capable of installation for a seismic component Importance Factor of 1.5.>> The BPS shall provide a minimum of four independent, fully supervised Class B circuits that can be field configurable for notification appliance circuits or auxiliary 24 Vdc power circuits. BPS NACs shall be convertible to a minimum of two Class A NACs. Each BPS output circuit shall be rated at 3 amperes at 24 Vdc. Each output circuit shall be provided with automatically restoring overcurrent protection. The BPS shall be operable from the main system NAC and/or Edwards Signature Series control modules. BPS NACs shall be configurable for continuous, 3-3-3 temporal or optionally, California rate. Fault conditions on the BPS shall not impede operation of main system NAC. The BPS shall be provided with ground fault detection circuitry and a separate AC fail relay.

Dimensions

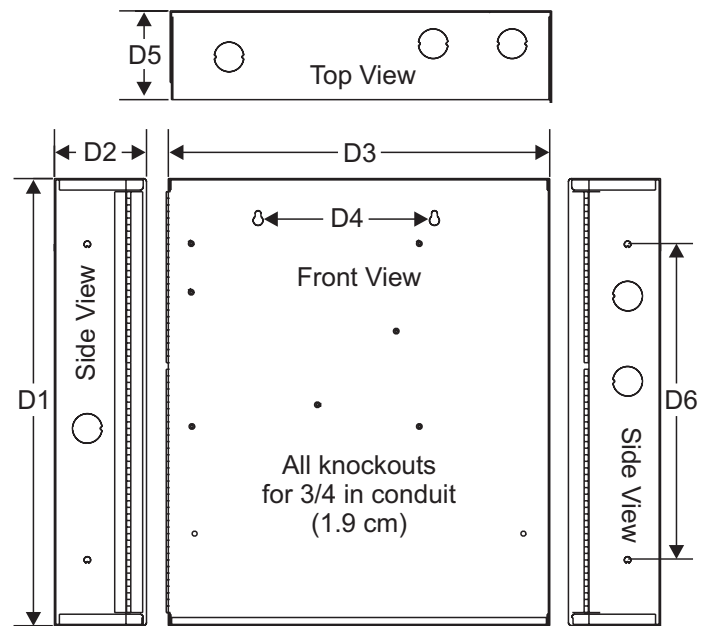

D1	D2	D3	D4	D5	D6
17.0 in (43.2 cm)	3.5 in (8.9 cm)	13.0 in (33.0 cm)	6.5 in (16.5 cm)	3.375 in (8.6 cm)	12.0 in (30.4 cm)

Wire routing

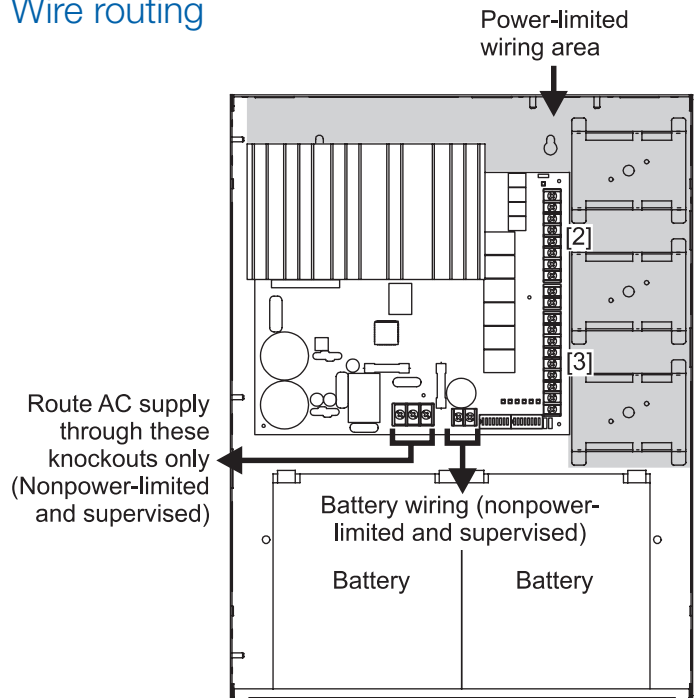

Notes

1. Maintain 1/4-inch (6 mm) spacing between power-limited and nonpower-limited wiring or use type FPL, FPLR, or FPLP cable per NEC.
2. Power-limited and supervised when not configured as auxiliary power. Non-supervised when configured as auxiliary power.
3. Source must be power-limited. Source determines supervision.
4. When using larger batteries, make sure to position the battery terminals towards the door.

Typical Wiring

Single or cascaded booster anywhere on a notification appliance circuit

Existing NAC end-of-line resistors are not required to be installed at the booster's terminals. This allows multiple boosters to be driven from a single NAC circuit without the need for special configurations.

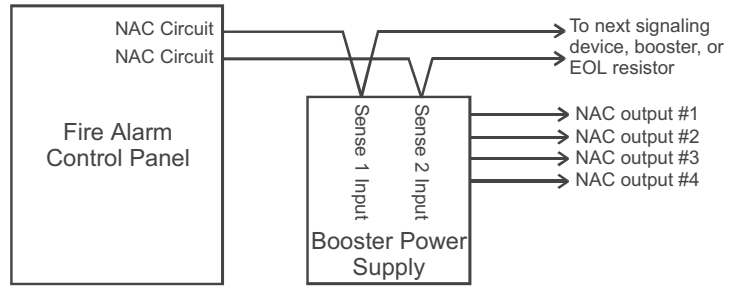

Configuring the Booster for AC Power Fail delay operation*

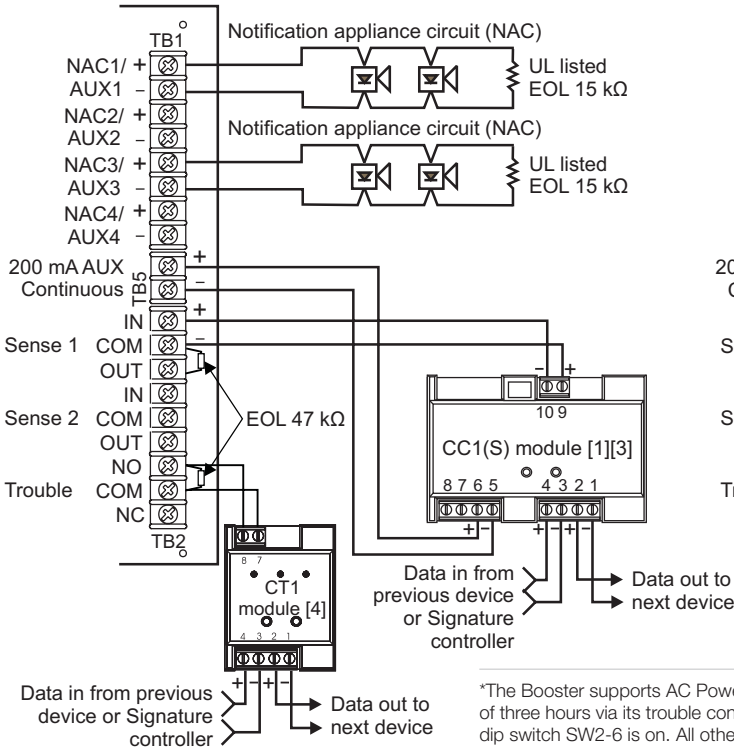

*The Booster supports AC Power fail delay of three hours via its trouble contact when dip switch SW2-6 is on. All other troubles are reported to supervising module or panel without delay via Sense inputs.

Multiple CC1(S) modules using the BPS's sense inputs

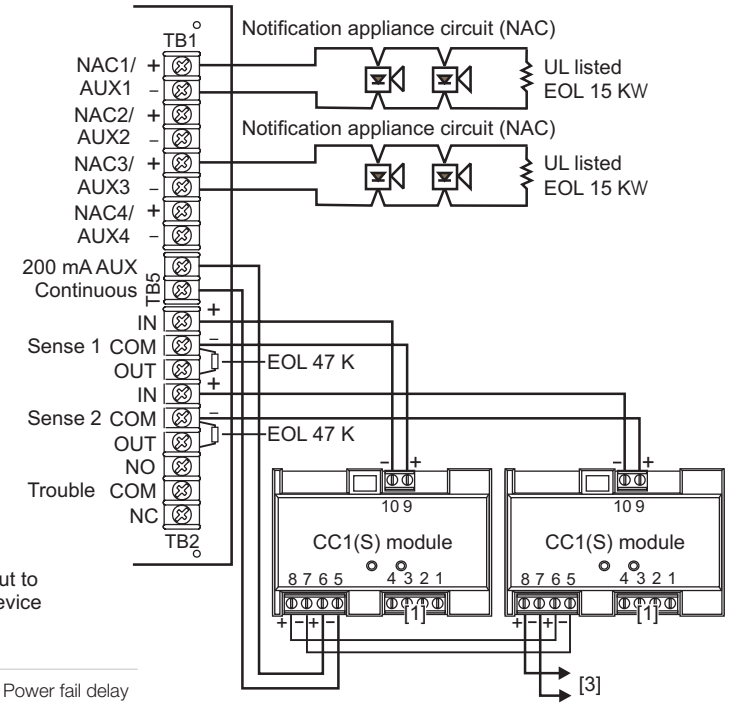

Security and access

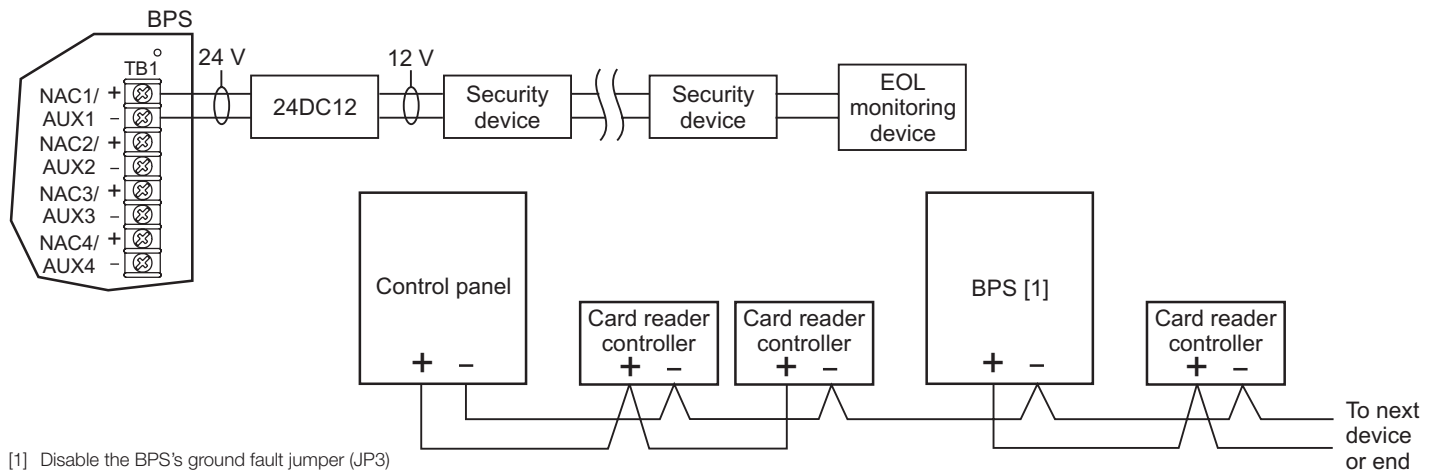

[1] Disable the BPS's ground fault jumper (JP3)



Detection & alarm since 1872

U.S.
T 888-378-2329
F 866-503-3996

Canada
Chubb Edwards
T 519 376 2430
F 519 376 7258

Southeast Asia
T : +65 6391 9300
F : +65 6391 9306

India
T : +91 80 4344 2000
F : +91 80 4344 2050

Australia
T +61 3 9239 1200
F +61 3 9239 1299

Europe
T +32 2 725 11 20
F +32 2 721 86 13

Latin America
T 305 593 4301
F 305 593 4300

utcfireandsecurity.com

© 2010 UTC Fire & Security.
All rights reserved.

Specifications

Model	6.5 amp Booster	10 amp Booster
AC Line Voltage	120VAC or 220-240VAC 50/60Hz 390 watts	120VAC or 220-240VAC 50/60Hz 580 watts
Notification Appliance Circuit Ratings	3.0A max. per circuit @ 24Vdc nominal 6.5A max total all NACs	3.0A max. per circuit @ 24Vdc nominal 10A max total all NACs
Trouble Relay	2 Amps @ 30Vdc	
Auxiliary Outputs	Four configurable outputs replace NACs 1, 2, 3 or 4. as auxiliary outputs and 200 mA dedicated auxiliary. (See note 2.)	
Input Current (from an existing NAC)	3mA @ 12Vdc, 6mA @ 24Vdc	
Booster Internal Supervisory Current	70mA	
Signature Mounting Space	Accommodates three two-gang modules.	
Maximum Battery Size	10 Amp Hours (2 of 12V10A) in cabinet up to 24 Amp hours with ex- ternal battery cabinet for fire and security applications; up to 65 Amp hours for access control applications in external battery box.	
Terminal Wire Gauge	18-12 AWG	
Relative Humidity	0 to 93% non condensing @ 32°C	
Temperature Rating	32° to 120°F (0° to 49°C)	
NAC Wiring Styles	Class A or Class B	
Output Signal Rates	Continuous, California rate, 3-3-3 temporal, or follow installed panel's NAC. (See note 1.)	
Ground Fault Detection	Enable or Disable via jumper	
Agency Listings	UL, ULC, CSFM	

1. Model BPS*CAA provides selection for California rate, in place of temporal.
2. Maximum of 8 Amps can be used for auxiliary output.

Ordering Information

Catalog Number	Description	Shipping Wt. lb (kg)
BPS6A	6.5 Amp Booster Power Supply	13 (5.9)
BPS6AC	6.5 Amp Booster Power Supply (ULC)	13 (5.9)
BPS6A/230	6.5 Amp Booster Power Supply (220V)	13 (5.9)
BPS6CAA	6.5 Amp Booster Power Supply with California rate	13 (5.9)
BPS10A	10 Amp Booster Power Supply	13 (5.9)
BPS10AC	10 Amp Booster Power Supply (ULC)	13 (5.9)
BPS10A/230	10 Amp Booster Power Supply (220V)	13 (5.9)
BPS10CAA	10 Amp Booster Power Supply with California rate	13 (5.9)

Related Equipment

12V6A5	7.2 Amp Hour Battery, two required	3.4 (1.6)
12V10A	10 Amp Hour Battery, two required	9.5 (4.3)
3-TAMP	Tamper switch	
BC-1EQ	Seismic Kit for BC-1. Order BC-1 separately. See note 3.	
BPSEQ	Seismic kit for BPS6A or BPS10 Booster Power Supplies. See note 3	
BC-1	Battery Cabinet (up to 2 - 40 Amp Hour Batteries)	58 (26.4)
BC-2	Battery Cabinet (up to 2 - 17 Amp Hour Batteries)	19 (8.6)
12V17A	18 Amp Hour Battery, two required (see note 1)	13 (5.9)
12V24A	24 Amp Hour Battery, two required (see note 1)	20 (9.07)
12V40A	40 Amp Hour Battery, two required (see notes 1, 2)	32 (14.5)
12V50A	50 Amp Hour Battery, two required (see notes 1, 2)	40 (18.14)
12V65A	65 Amp Hour Battery, two required (see notes 1, 2)	49 (22.2)

1. Requires installation of separate battery cabinet.
2. BPS supports batteries greater than 24 Amp hours for access control applications only.
3. For earthquake anchorage, including detailed mounting weights and center of gravity detail, refer to Seismic Application Guide 3101676. Approval of panel anchorage to site structure may require local AHJ, structural or civil engineer review.

**Click Here to Return to
Bill of Material/Index**

[Click Here to Return to Bill of Material/Index](#)



- wide input voltage range
- universal mounting
- built-in RFI filters
- 10,000 hour strobe lamp
- ten year warranty on power supply
- one year warranty on lamp
- available in six lens colors
- UL recognized (all models)
- lens has hermetic o-ring seal
- NEMA 4X

MICRO IV™

Low Profile - Single Flash Strobe

The MICRO IV strobe family is an enhanced version of the MICROSTROBE featuring a power supply which operates over a wide input voltage range of 12–80VDC or 16–24VAC. The supply has a regulated output so that the lamp brightness and flash remain constant when operated over the rated input voltage range. The power supply is potted in polyurethane for the ultimate in protection from moisture, vibration and exposure to high voltage. The enclosure is all Lexan®, and the plug-in lamp is field replaceable. All units are polarity protected and have built-in filters to protect against radio interference and spike voltages. The MICRO IV is covered by a 10 year warranty. The MICRO IV and its guard are UL component recognized for type E, EE, and ES electric industrial trucks covered by UL standard #583.

Lens Colors



Ordering Information

Please specify lens colors and model number when ordering. Available colors are Amber, Blue, Clear, Green, Purple and Red.

Model No.	Description	Voltage
470SSGP-1280	DC strobe, wall plate mount	12 – 80VDC
470S-1280	DC strobe, surface mount	12 – 80VDC
470SMB-1280	DC strobe, magnetic mount and 6' straight cord	12 – 80VDC
470SMB-1280/CC	DC strobe, magnetic mount and coil cord	12 – 80VDC
485S-1280	DC strobe, screw-in light bulb base	12 – 80VDC
490S-1280	DC strobe, 1/2" female pipe mount	12 – 80VDC
492S-1280	DC strobe, 3/4" IPS slip mount	12 – 80VDC
495S-1280	DC strobe, 1/2" male thread mount	12 – 80VDC

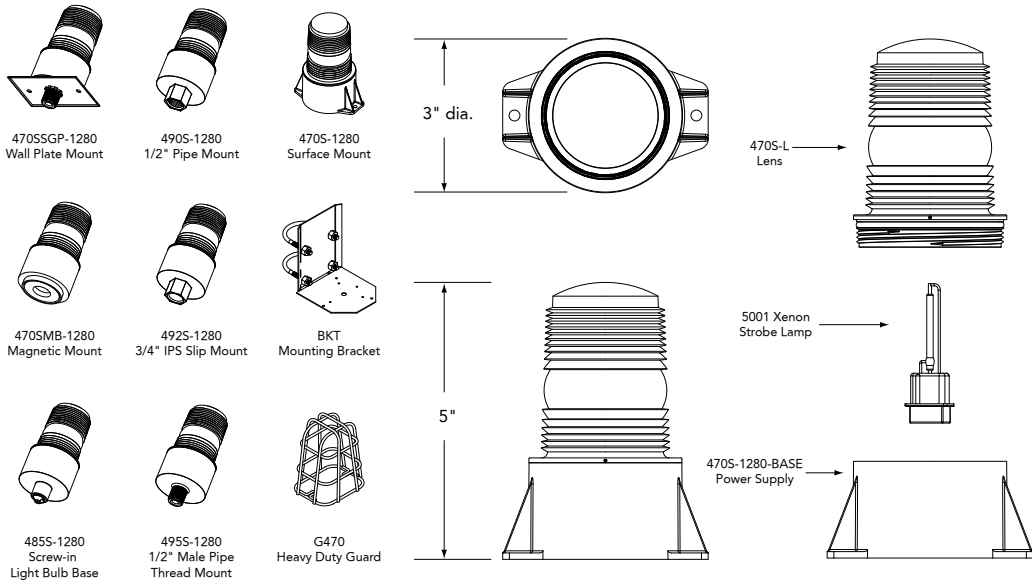

Specifications

Item	Description
Flash Rate	60 to 80 flashes per minute
Light Output	50 candela eff.
Voltage and Amperage	12-80VDC draws 0.4A average @ 12VDC tapering to 0.05A average @ 80VDC 16-24VAC draws 0.35A average
Power Supply Output 2.7 Watts	1.9 joules per flash
Size and Weight	5" tall x 3" dia. x 0.6 lbs (127mm x 76mm x 0.27kg)
Encapsulation	Fully potted in urethane material with no exposure to High Voltage possible

Available Options

NOTE: All "/" options are factory installed only.

Model No.	Description
G470	Heavy duty guard
BKT	Mounting bracket
LBO-MINI	Lens blackout segment 180°
MICROSHIELD	Vinyl, 180° lens blackout

Architect and Engineer Specifications

The strobe light shall be Tomar model number series 470, 480, 485, 490, 492, 495 or approved equal. The light source shall be a plug-in field replaceable single-flash xenon strobe tube. The strobe light must have built-in RFI filters to protect against radio interference and spike voltages. It shall be polarity protected, and have a power supply fully potted in polyurethane. Voltage ranges shall be 12-80VDC or 16-24VAC, 120 VAC, and 240VAC. The strobe light shall be UL listed and of NEMA 4X type weatherproof design with screw-on Lexan® lens.

Replacement Parts

Model No.	Description
5001	Xenon strobe lamp
470S-L	Colored lens (please specify color)
470S-1280-PSA	12 - 80VDC power supply, surface mount
470SMB-1280-PSA	12 - 80VDC power supply, magnetic mount and 6' straight cord
470SMB-1280/CCB	12 - 80VDC power supply, magnetic mount and coil cord
485S-1280-PSA	12 - 80VDC power supply, screw-in light bulb base
490S-1280-PSA	12 - 80VDC power supply, 1/2" female pipe mount
492S-1280-PSA	12 - 80VDC power supply, 3/4" IPS slip mount
495S-1280-PSA	12 - 80VDC power supply, 1/2" male thread mount

[Click Here to Return to Bill of Material/Index](#)

7744/7788

AES IntelliNet
CORPORATION | For Alarm Monitoring

NEW!

RF Subscriber Unit

UL Fire, AA Burglary and NFPA-72 Compliant

UL Listed

UL Listed Central
Station

Remote Station

864 Ed. 9, 827, 1610,
365, 681

CSFM

NFPA
RF Section 8.6.3.5

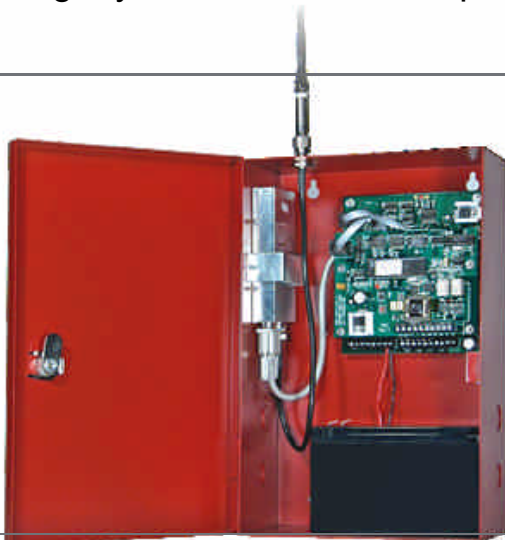

- Options for Full Data for Fire and Burglary
- Available in 7744 & 7788 Zone Configurations
- Built-in Power Supply and Battery Charger
- Local Annunciation Options on Board

Advanced Wireless Alarm Monitoring

The 7744/7788 smart subscriber unit links an alarm panel to an alarm monitoring central station. This 2-way transceiver and repeater in one is housed in a full size locking steel cabinet for superior performance. The 7744/7788 supports a wide range of inputs such as NO/NC/EOL and direct voltage. It automatically senses wire and antenna cuts, and monitors battery and AC power status. Advanced status reporting, self-diagnostics and a built-in power supply make the 7744/7788 the first choice for all wireless alarm communication needs.

Full Data for Fire and Burglary

Use with the optional Firetap for full fire data or the IntelliTap for full fire and burglary data.

Available Configurations

7744 – 4 reversing polarity inputs plus 4 programmable EOL inputs

7788 – Programmable EOL inputs with 8 zones

Available Options

FireTap 7770
IntelliTap 7067
NEMA 4 Enclosure
High Gain Antenna
Additional Back Up Battery
Available in Burglary Beige or Fire Red

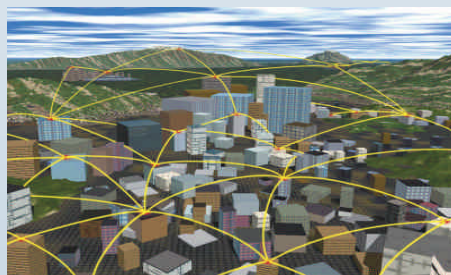

Wireless mesh networking is an innovative technology adopted by many industries with applications that need to communicate data over a large geographic area with a high level of reliability at a low total cost of ownership.

The advanced design and 2-way communications capability provides easy installation, expansion, and management when compared to alternative communication methods, both wired and wireless.

RF Subscriber Unit

Technical Specifications

Radio

Standard CSAA frequency ranges: 450-470 MHz and 130-174 MHz, VHF and UHF. Others available

Standard Output Power

2 watts (requires FCC license)

Power Input

16.5 VAC, 40VA UL listed
Class II transformer required

Voltage

12 VDC nominal

Current

175mA standby; 800mA transmit

Alarm Signal Inputs

- 4 individually programmable Zones: NO/NC/EOL, trouble restore
- RS-232
- Reversing voltage (7744 only) 12 or 24 VDC

Operating Temperature Range

0° to 50°C, 32° to 122°F

Storage Temperature Range

-10° to 60°C, 14° to 140°F

Relative Humidity Range

0-85% RHC non-condensing

Back up Battery

12V, 7 AH

Low Battery Reporting

22.5-minute test cycle

AC Status

Reports to central station after approximately 60 minutes without AC power, reports power restored after approximately 60 minutes of restored power. programmable from 60 to 180 minutes

Antenna Cut (local reporting)

Form 'C' Contact 1 AMP

Size

13.25"H x 8.5"W x 4.3"D
34cm x 21.5cm x 11cm

Weight

6.4 lbs, 2.9 Kilograms
(excluding battery)

Colors

Available in standard
Burglary Beige or Fire Red
Please specify when ordering

Available Options

- 7788 RF subscriber unit with 8 EOL inputs
 - 7744 RF subscriber unit with 4 EOL inputs and 4 reverse polarity inputs
 - 7770 - FireTap
 - 7067 - IntelliTap
 - NEMA 4 Enclosure
- Please specify when ordering

Available configurations

- 7788, 8 EOL inputs
- 7744, 4 EOL inputs w/4 reverse polarity inputs

AES-IntelliNet™ is the industry leader in delivering high quality wireless mesh networks to the fire and security industry in commercial, corporate, government, and educational applications with its broad line of products and advanced network management tools. Users of AES-IntelliNet networks have gained significant revenue, communications, and cost advantages while meeting the high standards of reliability required for the fire and security industry. AES-IntelliNet alarm monitoring systems are deployed at hundreds of thousands of locations in over 130 countries.



For more information

Call 800-AES-NETS (800-237-6387)

AES Corporation | 285 Newbury Street | Peabody, MA 01960 USA

Tel. +1 978-535-7310 | Fax +1 978-535-7313 | Email info@aes-intellinet.com

Web www.aes-intellinet.com

[Click Here to Return to Bill of Material/Index](#)

Copyright 2008 AES Corporation
AES-IntelliNet is a registered trademark of AES Corporation

7744/7788/02/08

[Click Here to Return to Bill of Material/Index](#)

Electromagnetic Door Holders

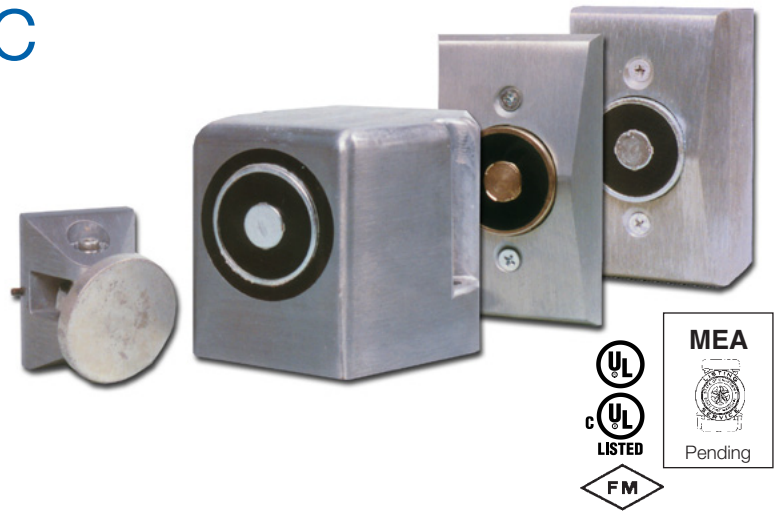

Overview

Edwards Electromagnetic Door Holders are ruggedly constructed and attractively designed. The housing is finished with an aluminum color, durable baked polyester powder paint. The floor or wall section houses the electromagnet while the contact plate attaches to the door. The contact plate has a shock absorbing nylon (swivel) ball which allows the plate to adjust to any door angle. Floor units are available in single-door or double-door (back to back) versions. Wall units are available in flush or surface mounted versions.

Edwards door releases should be installed wherever doors may be effectively used to confine smoke and fire, or where the release of a self-closing door from a remote location is desirable for other reasons.

Fail-safe operation is an inherent feature of Edwards door holder-releases. If power fails, doors are released automatically but may be opened or closed manually at any time. All units are free of moving parts, are self-contained and require no maintenance.

These door holder-releases have a holding force of approximately 15 to 25 Lbf (66 to 111N). The device holds a door open while energized. When de-energized by a relay controlled by the fire alarm system or other switch, the door is released to a closed position, checking the spread of smoke and flames. Electromagnetic door holders should be used and installed in accordance with local Building Codes and Standards.

Standard Features

- Floor and wall mounted styles
- Low power consumption
- AC/DC models
- Completely silent operation
- 25 Lbf (111N) nominal holding force
- Adjustable, swivel contact plate

Basic Models

Floor Mounted:

The electromagnet portion consists of a floor plate and a floor housing which when installed with gaskets provided, form a weatherproof electrical junction box. Incoming conduit connects directly into floor plate.

Floor mounted units are available with one (Cat. No. 1501) or two (Cat. No. 1502) magnet faces for holding a single door or two doors back to back.

Wall Mounted:

Wall mounted models are available in flush, semi-flush and surface mounting configurations. Flush and semi-flush models are designed for concealed wiring applications and mount on standard single gang (2 x 4 inch) outlet boxes. Surface mounted models mount on a surface adaptor housing (junction box), which is provided.

Dimensions

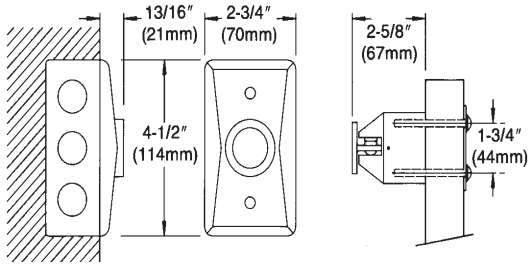

1504-AQN5 Flush Wall Mounted (Long Catch Plate)

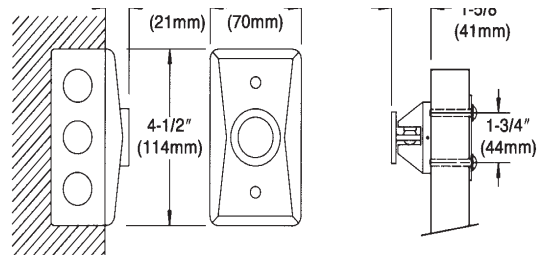

1505-AQN5 Flush Wall Mounted (Short Catch Plate)

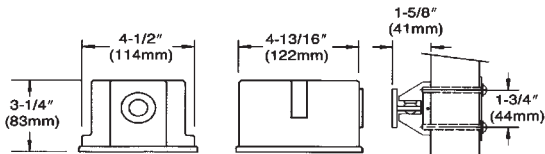

1501-AQN5 Floor Mounted (Single Door)

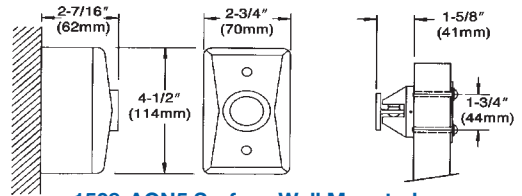

1508-AQN5 Surface Wall Mounted

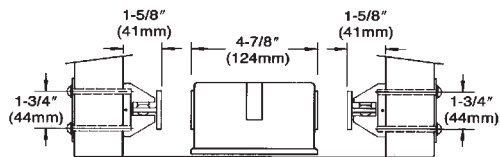

1502-AQN5 Floor Mounted (Double Door)

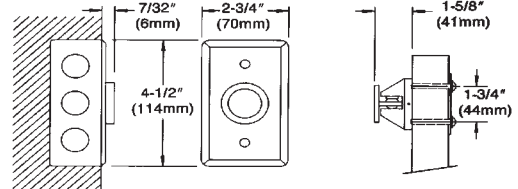

1509-AQN5 Completely Flush Wall Mounted

Catch Plate Extensions

Only the extension rods are included. The end pieces are included with the doorholders or can be ordered separately.

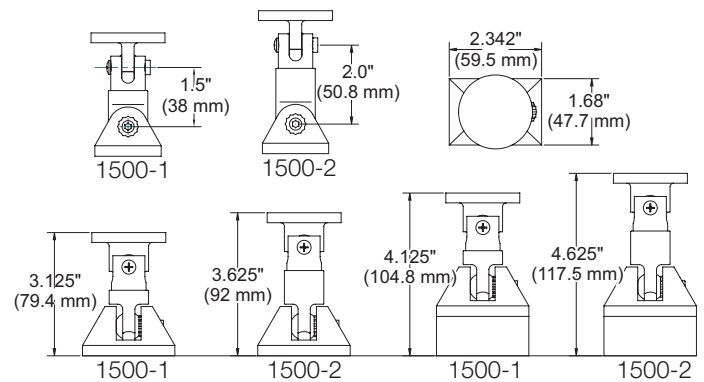
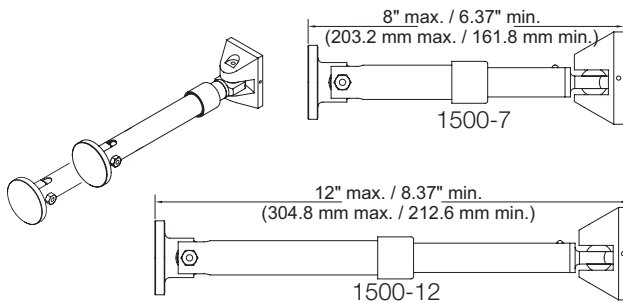

Specifications

Model No.	Style	Volts	Amps*
1501-AQN5	Floor Mounted (Single Door)		
1502-AQN5	Floor Mounted (Double Door)		
1504-AQN5	Flush Wall Mounted (Long Catch Plate)	24 Vac 60 Hz	
1505-AQN5	Flush Wall Mounted (Short Catch Plate)	24 Vdc 120 Vac 60 Hz	.015
1508-AQN5	Surface Wall Mounted		
1509-AQN5	Completely Flush Wall Mounted		

*1502-AQN5 is a double unit which draws .015 per side

Ordering Information

Model No.	Description	Ship. Wt. lb (kg)
1501-AQN5	Floor Mounted (Single Door)	5.4 (2.45)
1502-AQN5	Floor Mounted (Double Door)	5.0 (2.27)
1504-AQN5	Flush Wall Mounted (Long Catch Plate)	2.0 (0.91)
1505-AQN5	Flush Wall Mounted (Short Catch Plate)	2.0 (0.91)
1508-AQN5	Surface Wall Mounted	3.0 (1.36)
1509-AQN5	Completely Flush Wall Mounted	2.0 (0.91)

Accessories

1500-1	Catch plate extension assembly, 1.5"	0.25 (0.11)
1500-2	Catch plate extension assembly, 2.5"	0.25 (0.11)
1500-7	Catch plate extension assembly (5.25 to 7.5 inches)	0.5 (0.23)
1500-12	Catch plate extension assembly (7.5 to 12 inches)	1.0 (0.45)
CS2595-5	Replacement armature - short (for use with 1501, 1502, 1505, 1508 and 1509 door holders)	0.25 (0.11)
CS2598-5	Replacement armature - long (for use with 1504 door holder)	0.25 (0.11)

CAUTION: These Door Holder units will not operate without electrical power.



Detection & alarm since 1872

U.S.

T 888-378-2329

F 866-503-3996

Canada

Chubb Edwards

T 519 376 2430

F 519 376 7258

Southeast Asia

T : +65 6391 9300

F : +65 6391 9306

India

T : +91 80 4344 2000

F : +91 80 4344 2050

Australia

T +61 3 9239 1200

F +61 3 9239 1299

Europe

T +32 2 725 11 20

F +32 2 721 86 13

Latin America

T 305 593 4301

F 305 593 4300

utcfireandsecurity.com

© 2010 UTC Fire & Security.

All rights reserved.

[Click Here to Return to
Bill of Material/Index](#)



Multi-Voltage Conventional Relays

System Sensor's multi-voltage conventional relays are used for high-current switching applications such as fan and damper assembly control, door control, air handling unit controls, and other types of system interfacing.

Features

- Multi-voltage operation
- Activation LEDs
- Easy and flexible installation
- Reliable and robust design
- Multipurpose field installations
- Multi-voltage relays with terminal strip field wiring connections, mounting track, and hardware for R-10T/20T and R-14T/24T
- Removable front cover on steel enclosure for R-10E/R-20E and R-14/R-24E, which mount inside the enclosure
- LED viewing hole on top of the steel enclosure's cover
- Extra pair of wires for redundant power input on PR-3
- Terminal strip field wiring connections, mounting track, and hardware

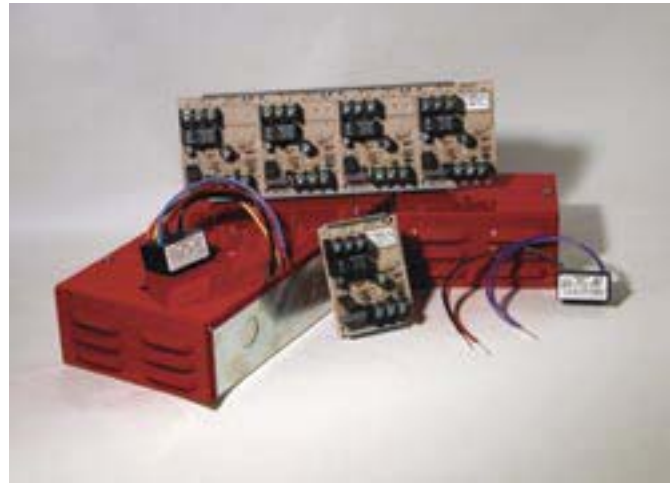

The R-10T, R-20T, R-14T, and the R-24T models are multi-voltage relays with terminal strip field wiring connections, mounting track, and hardware. The R-10T is a single FORM-C (SPDT) relay with a red activation LED, and the R-14T is a four-gang 1 FORM-C (SPDT) relay with four red activation LEDs. The R-20T is a single 2 FORM-C (DPDT) relay with a red activation LED, and the R-24T is a four-gang 2 FORM-C (DPDT) relay with four red activation LEDs.

The R-10E/R-20E and R-14E/R-24E are similar to the T-series track mount relays, but they are mounted into a steel enclosure. The enclosure has a removable front cover that provides easy access and an LED viewing hole on the top of the cover.

PR-1/PR-2/PR-3 are epoxy encapsulated multi-voltage relays. They are single-pole double-throw relays that use a red LED as a visible indication of relay coil energization. PR-3 is identical to PR-2, except it has an extra pair of wires for redundant power input.

Model EOLR-1 is an epoxy encapsulated, single-pole single-throw, normally open relay that can be used as an end of line device in fire alarm systems, e.g. to supervise power supplies.

Agency Listings



MEA
approved

Multi-Voltage Conventional Relay Specifications

Specifications: R-10T/R-14T/R-20T/R-24T	
Operating Voltage	18 – 35 VDC, 18 – 35 VAC, 115 VAC, 230 VAC
Operating Current	20 mA DC max. @ 24 VDC, 24 VAC, 115 VAC, 230 VAC (R-10T/R-14T) 40 mA DC max. @ 24 VDC, 24 VAC, 115 VAC, 230 VAC (R-20T/R-24T)
Operating Temperature	-40°F to 158°F (-40°C to 70°C)
Humidity Range	10% – 93% non-condensing
Dimensions	R-10T/R-20T: 2.5" L × 3.35" W × 1.2" H R-14T/R-24T: 10" L × 3.35" W × 1.2" H
Contact Ratings	24 VDC: 7 A with L/R = 5 mS 120 VAC: 10 A 120 VAC: 1/6 HP 230 VAC: 7 A
Specifications: R-10E/R-14E/ R-20E/R-24E	
Operating Voltage	18 – 35 VDC, 18 – 35 VAC, 115 VAC, 230 VAC
Operating Current	20 mA DC max. @ 24 VDC, 24 VAC, 115 VAC, 230 VAC (R-10E/R-14E) 40 mA DC max. @ 24 VDC, 24 VAC, 115 VAC, 230 VAC (R-20E/R-24E)
Operating Temperature	-40°F to 158°F (-40°C to 70°C)
Humidity Range	10% – 93% non-condensing
Dimensions	R-10E/R-20E: 5.1" L × 3.75" W × 2.5" H R-14E/R-24E: 11" L × 5.3" W × 2.5" H
Contact Ratings	24 VDC: 7 A with L/R = 5 mS 120 VAC: 10 A 120 VAC: 1/6 HP 230 VAC: 7 A

Specifications: PR-1	
Operating Voltage	18 – 35 VDC, 18 – 35 VAC, 120 VAC
Operating Current	15 mA DC max. @ 24 VDC, 24 VAC, 120 VAC
Operating Temperature	-40°F to 158°F (-40°C to 70°C)
Humidity Range	10 – 93% RH
Wire Length	8" minimum
Dimensions	0.87" H × 2.01" W × 1.42" D
Contact Ratings	24 VDC: 7 A with L/R = 5 mS 120 VAC: 7 A max. (0.35 PF) 250 VAC: 10 A resistive 30 VDC: 10 A resistive

Specifications: PR-2/PR-3	
Operating Voltage	10 to 40 VDC
Operating Current	30 mA DC max.
Operating Temperature	-40°F to 158°F (-40°C to 70°C)
Humidity Range	10 – 93% RH
Wire Length	8" minimum
Dimensions	0.91" H × 1.65" W × 1.22" D
Contact Ratings	120 VAC: 10 A max. (resistive load) 120 VAC: 7 A max. (0.35 PF) 250 VAC: 10 A max. (resistive load) 30 VDC: 10 A max. (resistive load)

Specifications: EOLR-1	
Operating Voltage	9 to 40 VDC
Operating Current	20 mA DC max.
Operating Temperature	-22°F to 140°F (-30°C to 60°C)
Humidity Range	10 – 93% RH
Wire Length	8" minimum
Contact Ratings	120 VAC: 0.5 A max. (resistive load) 30 VDC: 3 A max. (resistive load)



PR-1



EOLR-1



PR-3

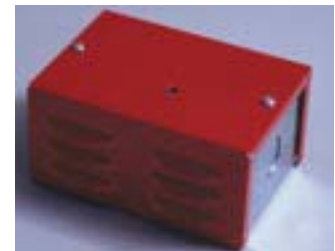

R-10E & R-20E Enclosure



PR-2



R-10T

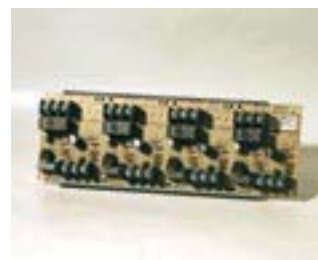

R-14T



R-14E & R-24E Enclosure

Click Here to Return to
Bill of Material/Index



AFTER ASSEMBLY COVER THIS SECTION W/ 2 3/4\"/>

STANDOFF BRACKET (4\"/>

EXTERIOR ANTENNA (WHEN REQUIRED) SEE DETAIL 'A'
TRANSMISSION WIRE MUST BE PROTECTED FROM ANTENNA TO RADIO BOX CONTINUOUSLY

EXTERIOR INTERIOR

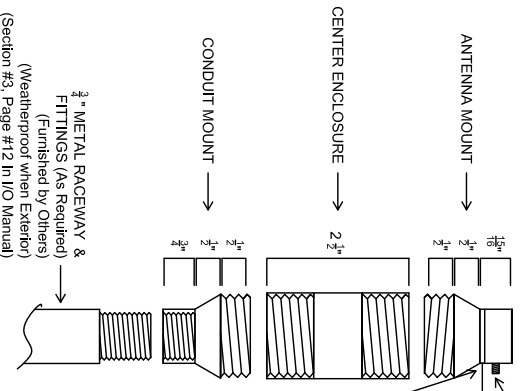

3/4\"/>

DETAIL "A"

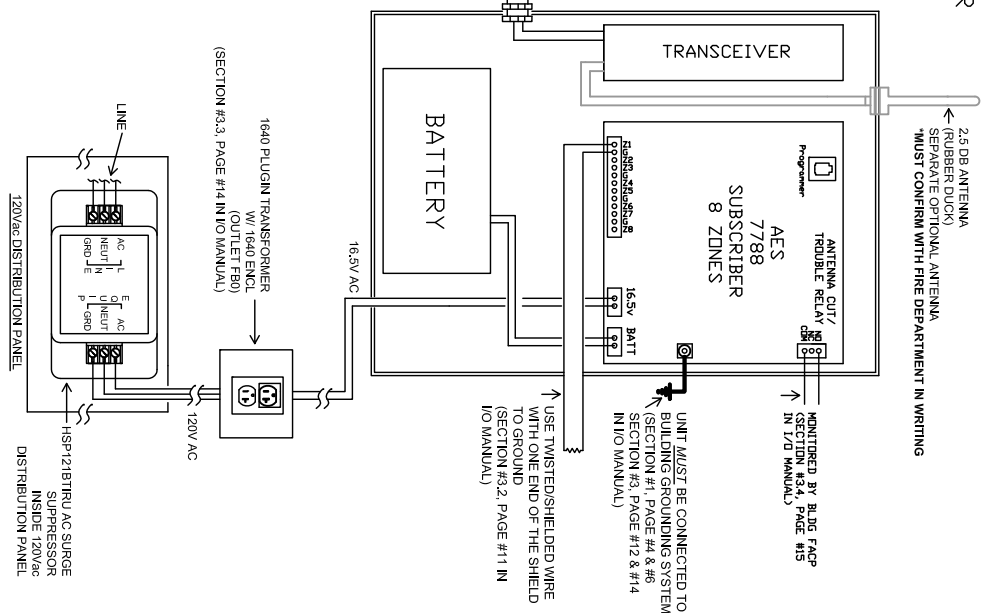

DWG NAME: AES Radio Transceiver Installation

R.B. Allen Co., Inc.
P.O. BOX 770
131 LA SALLE AVENUE #0
ND, HAMPTON, NH 03862
1-800-258-7264

DIGITIZE
ISO 9001:2000

SCALE: NTS

REV.	DESCRIPTION	DATE	DRWN	RWDD
0	Original Issue	4/09	DH	TD

AES Radio Transceiver Installation

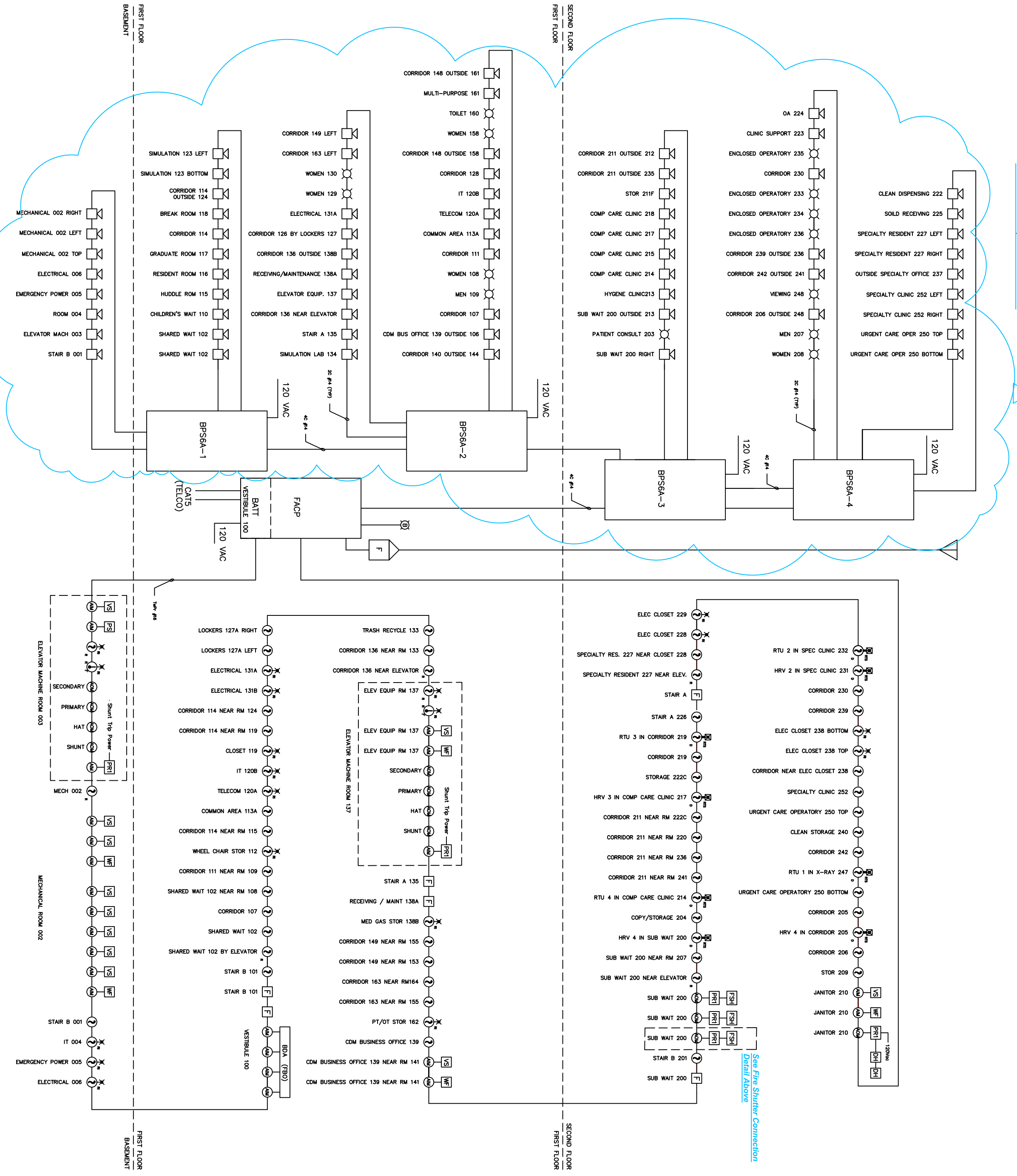

Elevator Shunt Trip Connection Detail

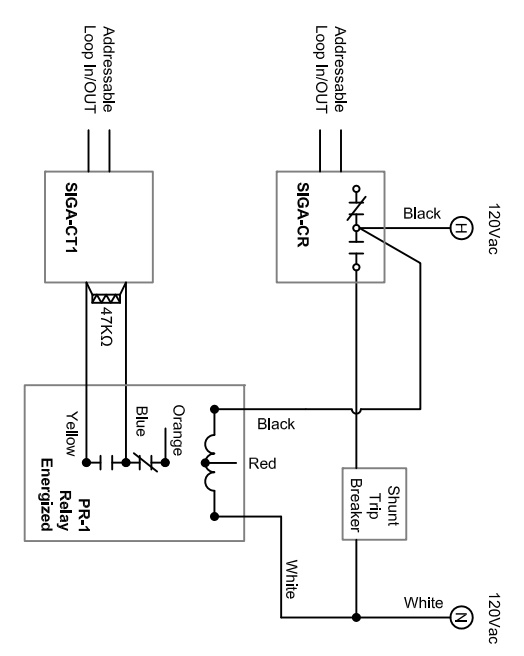

Fire Switcher Connection Detail

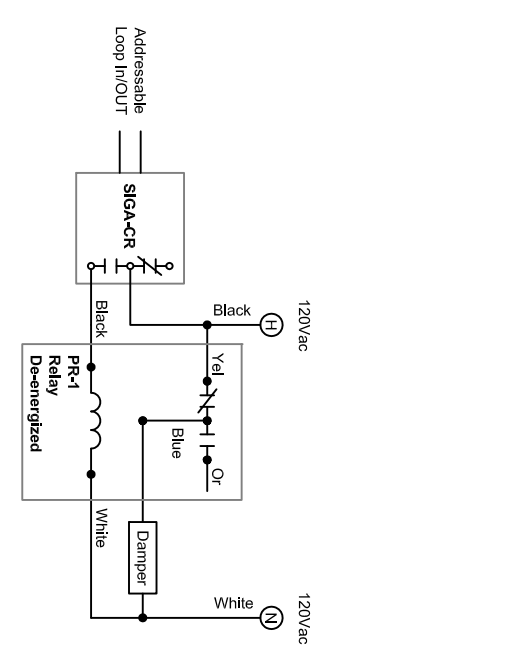

Sprinkler Bell Connection Detail

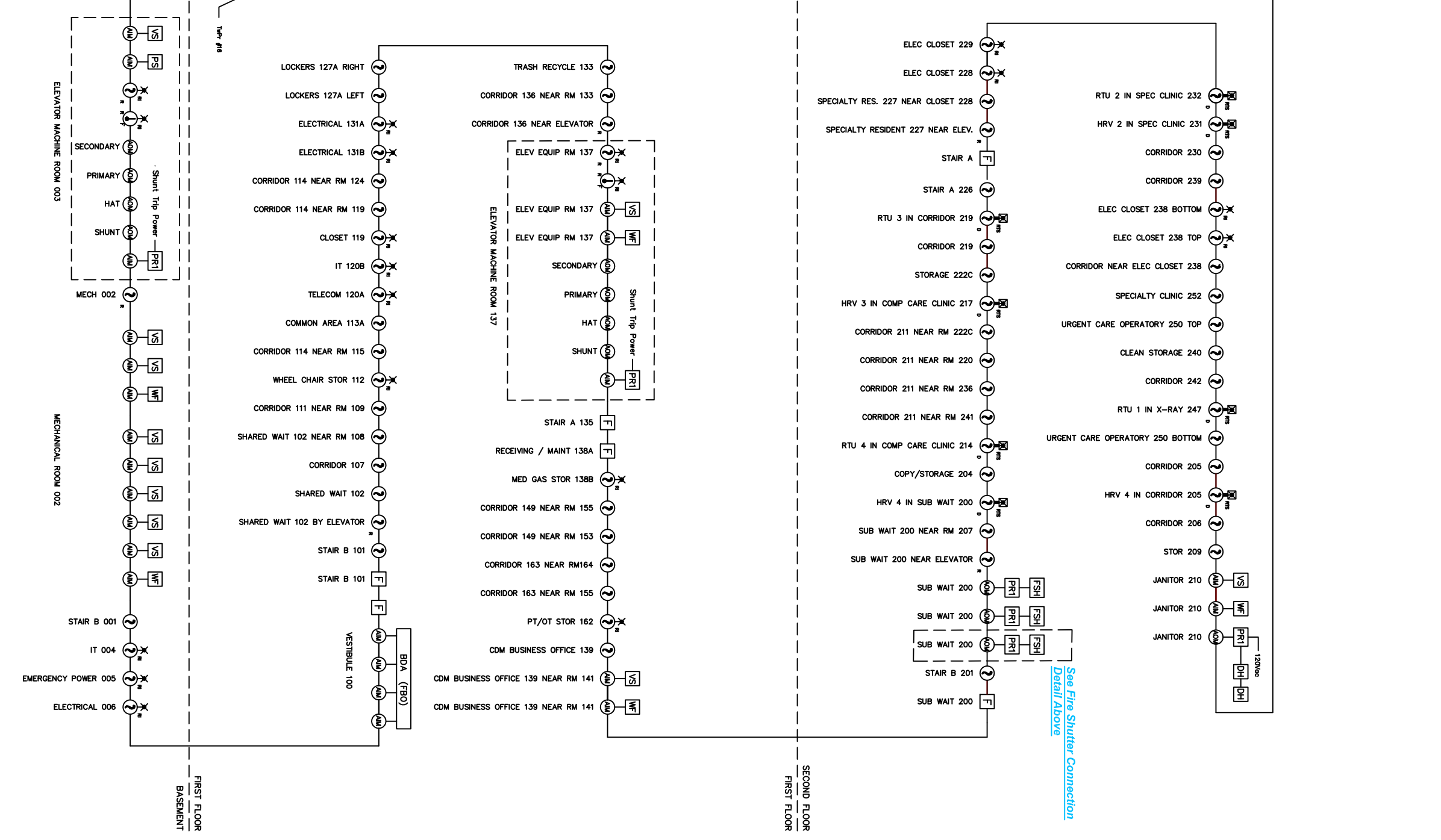
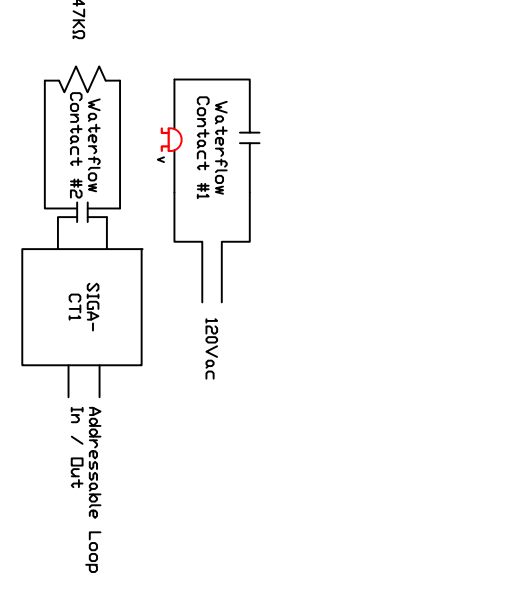

CLICK HERE TO RETURN TO BILL OF MATERIALS/INDEX

- WIRING NOTES:**
- All addressable devices must be installed in a heated room.
 - Addressable Loop consists of: (1) 2c #16 Twisted Non-shielded from FACP/FATC to 1st device; (1) 2c #16 Twisted Non-shielded through remaining devices on circuit and return to FACP/FATC. Maintain proper separation between feeds and returns.
 - Notification circuits consist of a minimum: 2c #14 from Booster Panel to 1st device; 2c #14 through remaining devices on circuit and return to Booster Panel. Maintain proper separation between feeds and returns.
 - Booster trip circuit consists of (1) 4c #14 from FACP to booster, through all subsequent boosters, and return to FACP. Maintain proper separation between feeds and returns.

GENERAL NOTES:

- ALL WIRING IN ACCORDANCE WITH NATIONAL ELECTRICAL CODE, APPROPRIATE STATE AND LOCAL CODES, AND MANUFACTURER'S REQUIREMENTS & RECOMMENDATIONS.

NOTE: NOT ALL SYMBOLS SHOWN ARE USED IN THE DRAWING.
 *NFPA 704 (2009) Tables 6.5, 6.7.1, 6.7.2 & 6.7.3

LEGEND:	CONTRACT SYMBOL	NFPA SYMBOL*	DESCRIPTION
[Symbol]	FACP	FACP	FIRE ALARM CONTROL PANEL
[Symbol]	FAL	FAL	FIRE ALARM ANNUNCIATOR
[Symbol]	BPS	BPS	BOOSTER
[Symbol]	BATT	BATT	BATTERY PACK & CHARGER
[Symbol]	F	F	MANUAL PULL STATION
[Symbol]	①	①	SMOKE DETECTOR
[Symbol]	②	②	SMOKE DETECTOR ASSOCIATED WITH ELEVATOR RECALL
[Symbol]	③	③	HEAT DETECTOR
[Symbol]	④	④	REMOTE ALARM INDICATOR
[Symbol]	⑤	⑤	DIAGNOSTIC SMOKE DETECTOR W/ SAMPLING TUBE
[Symbol]	⑥	⑥	REMOTE ALARM INDICATOR & KEY TEST STATION
[Symbol]	⑦	⑦	ADDRESSABLE INPUT MODULE
[Symbol]	⑧	⑧	ADDRESSABLE OUTPUT MODULE
[Symbol]	⑨	⑨	CONTROL RELAY
[Symbol]	⑩	⑩	WATERFLOW SWITCH
[Symbol]	⑪	⑪	TAMPER (VALVE SUPERVISION) SWITCH
[Symbol]	⑫	⑫	PRESSURE SWITCH
[Symbol]	⑬	⑬	CHECK VALVE PRESSURE SWITCH
[Symbol]	⑭	⑭	SMOKE DAMPER
[Symbol]	⑮	⑮	STROBE UNIT
[Symbol]	⑯	⑯	SPEAKER STROBE
[Symbol]	⑰	⑰	HORN STROBE
[Symbol]	⑱	⑱	HORN STROBE (WEATHER PROTECTED)
[Symbol]	⑲	⑲	HORN STROBE (CEILING MOUNTED)
[Symbol]	⑳	⑳	MINI HORN
[Symbol]	㉑	㉑	EXTERIOR BEACON (SL INDICATES SIGNAL LAMP)
[Symbol]	㉒	㉒	BELL
[Symbol]	㉓	㉓	BELL - CHIME
[Symbol]	㉔	㉔	MASTER BOX
[Symbol]	㉕	㉕	KNOX BOX
[Symbol]	㉖	㉖	DOOR HOLDER
[Symbol]	㉗	㉗	RADIO BOX
[Symbol]	㉘	㉘	ANTENNA

SCALE: NTS			
REV. 1	Revised per Submittal R0 comments.	10/12/12	PFO TD
REV. 0	REVIEW DRAWING	10/12/12	PFO TD
REV.	DESCRIPTION	DATE	DRWN: RWV'D:

JOB NAME: U.N.E. PATIENT CARE
 PORTLAND, MAINE
 FIRE ALARM RISER DIAGRAM

R.B. Allen Co., Inc.
 P.O. BOX 770
 131 LAFAVETTE RD
 NO. HAMPTON, NH 03862
 1-800-258-7264

DWG NAME: U.N.E. PATIENT CARE
 PORTLAND, MAINE
 FIRE ALARM RISER DIAGRAM
 DWG NAME: 158