



Click Here to Return to
Bill of Material/Index

Monitor
Module

EST3 Power Supplies

3-PPS/M series, 3-BPS/M series,
3-BBC/M series

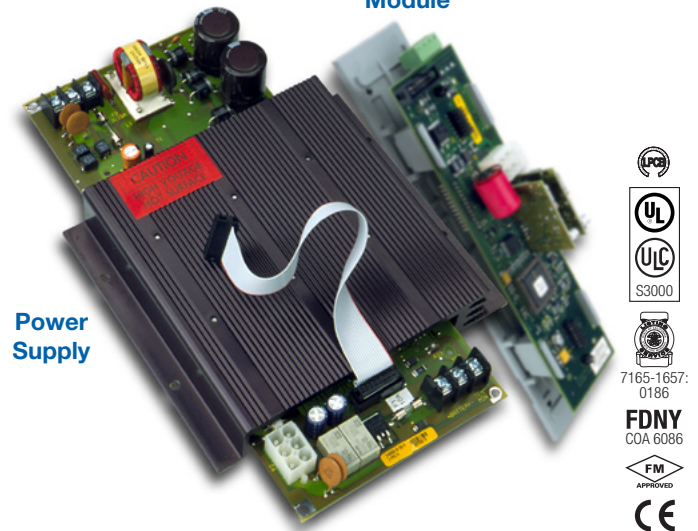

Power
Supply

Overview

EST3 Power supplies consist of two assemblies, a high efficiency switch mode power supply card and a power supply monitor module. The monitor module mounts to the local rail and distributes the power from its supply to the local rail. The local rail distributes power from all power supplies to other local rail modules and user interface cards resulting in "Shared Power" throughout the system. By paralleling the power supplies on a rail maximum utilization of available power is possible, resulting in fewer power supplies. Up to four power supplies combine in a single enclosure providing up to 28 amps of available power. Battery backup is provided using from one to four sets of batteries, depending on standby power requirements.

Power supplies mount to the back of the chassis units or wall-boxes. The associated power supply monitor module mounts on the local rail providing system power distribution and mounting space for any control display module. Access to auxiliary power is via easily accessible terminal blocks located on the power supply monitor module. Each power supply produces 7 Amps of filtered and regulated power. With four power supplies located in an enclosure (one primary and three booster power supplies) 28 amps of current is available for local rail modules, control display modules and the eight auxiliary 3.5 amp power outputs (two per supply).

Standard Features

- High efficiency switch mode
- Increased power distribution efficiency
 - power supplies parallel allowing up to 28 amps in a single node
- 120 or 230 Vac operation
- 7 AMP filtered and regulated
- Two 3.5 AMP outputs
- Temperature compensated, dual rated battery charger
- Electronic power limiting
- Automatic load testing of batteries
- Fully approved UL, ULC and EN standards (see Specifications section)

Application

The primary power supply provides the system with battery charging and voltage regulation. Software configures the charger to either 10-24 AH batteries or 30-65 AH batteries and controls the high/low charge rates. Batteries mounted in the same enclosure as the power supply, have their charge rate monitored and adjusted based on the local enclosure temperature, keeping charging rates within battery specification. For remote batteries a temperature probe is monitored in the remote battery cabinet and charge rates are adjusted automatically. Battery damage is unlikely to occur when environmental short term conditions are outside of normal operating ranges.

The EST3 power supplies automatically load test batteries by shutting down the battery charger and placing a load across the battery. If the battery voltage is outside the specification range the power supply reports a trouble. The trouble clears if the battery is able to recover and pass future load tests.

Battery leads are electronically short circuit protected. If a short occurs in the battery leads the charger automatically disables itself and causes a trouble. The system will constantly look to see if the short has cleared. If the short clears the system automatically restores.

During operation on standby batteries, battery voltage is constantly monitored. A trouble is reported if the battery voltage falls below a specified value.

EST3 power supplies provide specific information back to the 3-CPU(1) designed to help speed trouble shooting of system functions. Should a power supply detect a fault, specific diagnostic codes are available to speed trouble shooting. The 3-LCD will display the power supplies address, a specific trouble code, and a text message describing the specific trouble. Text messages are easy to understand and include items like: Battery Trouble, Aux Power Overload Circuit 1, Aux Power Overload Circuit 2.

Engineering Specification

The fire alarm power supplies must be capable of being paralleled and to load share. Multiple power supplies must be capable of being backed up with a single 24 volt battery set. Each power supply shall be capable of charging up to 65 AH batteries. The power supply must be able to perform an automatic load test of batteries and return a trouble if the batteries fall outside a predetermined range. Power supplies must incorporate the ability to adjust the charge rate of batteries based on ambient temperatures. It shall be possible to adjust for ambient temperature changes in local cabinets as well as remote cabinets.

Installation and Mounting

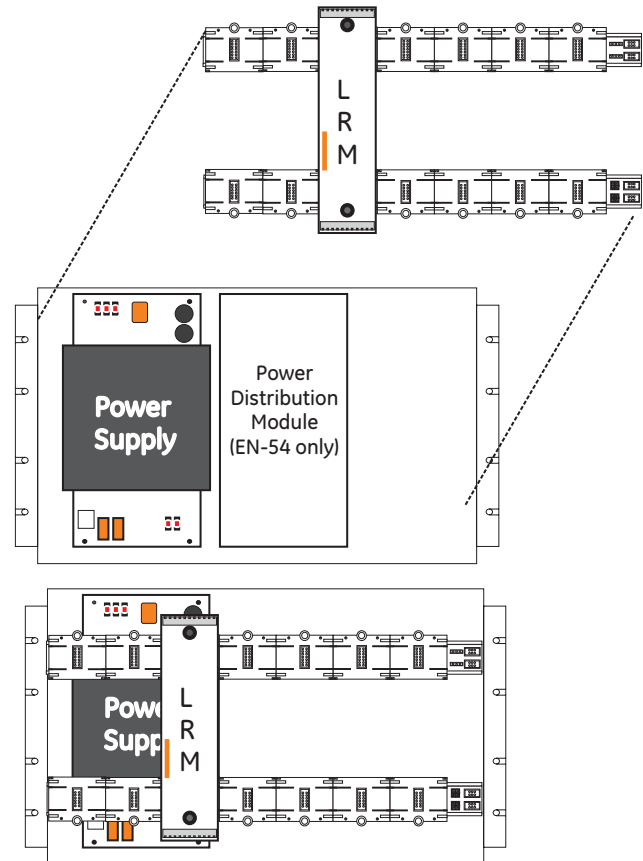

Power Supply Rules

1. Each battery set needs one charger, either a 3-PPS/M or a 3-BBC/M.
2. Each power supply must be connected to a battery set using an identical length and gauge of wire to keep voltage drops identical.
3. Distribute power supplies and loads evenly across rails.

4. All battery sets for a panel must be the same capacity (AH), same manufacturer, and same manufacturing date code.

The Table below illustrates the combinations of power supplies and batteries that meet all the power supply rules.

24 VDC Power Supply Output Current

| | 7A | 14A | | 21A | | 28A | |
|----------------------|--------------------|------------------------|-------------------------------|------------------------|---------------------------------|------------------------|--------------------------------|
| Battery Requirements | One Set, 65 AH max | One Set, 65 AH max | Two Identical Sets, 65 AH max | One Set, 65 AH max | Three Identical Sets, 65 AH max | One Set, 65 AH max | Four Identical Sets, 65 AH max |
| Required Modules | 1 3-PPS/M | 1 3-PPS/M 1 3-BPS/M | 1 3-PPS/M 1 3-BBC/M | 1 3-PPS/M 2 3-BPS/M | 1 3-PPS/M 2 3-BBC/M | 1 3-PPS/M 3 3-BPS/M | 1 3-PPS/M 3 3-BBC/M |

Typical Wiring

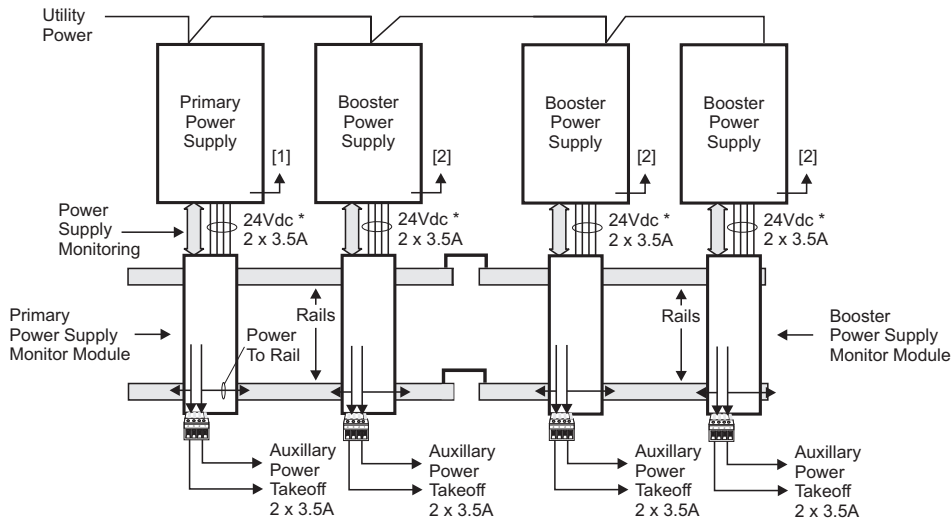

[1] From battery temperature probe terminals.

[2] From battery and from temperature probe terminals if 3-BTSEN-E used.

* Nominal Voltage

Agency Listings

EST3 is listed to the following UL and ULC standards:

UL 864, Control Units and Accessories for Fire Alarm Systems; **UL294**, Access Control System Units; **UL365**, Police Station Connected Burglar Alarm Units and Systems; **UL609**, Local Burglar Alarm Units and Systems; **UL636**, Police Station Connected Burglar Alarm Units and Systems; **UL1076**, Proprietary Burglar Alarm Units and Systems; **UL1610**, Central Station Burglar Alarm Units; **UL1635**, Digital Alarm Communicator System Units; **UL2017**, General-Purpose Signaling Devices and Systems; **ULC-S303-M91**, Local Burglar Alarm Units and Systems; **ULC-S527-99**, Control Units for Fire Alarm Systems; **ULC/ORD-C1076**, Proprietary Burglar Alarm Units and Systems; **CAN/ULC-S559-04**, Equipment for Fire Signal Receiving Centres and System; **ULC/ORD-C100**, Smoke Control System Equipment

Specifications

| Catalog Number | 3-PPS/M & 3-BBC/M | 3-BPS/M | 3-PPS/M-230 & 3-BBC/M-230 | 3-BPS/M-230 | 3-PPS/M-230-E & 3-BBC/M-230-E | 3-BPS/M-230-E |
|------------------------------------|------------------------------------------------------------------------------------------------------------------------------------------------------------------------------|----------------------------|-----------------------------------------------------------------------------------------------|--------------------------------|---------------------------------------------------------------------------------------------------|-------------------------------------|
| Agency Approvals | UL, ULC | U L, ULC | UL, ULC | UL, ULC | LPCB EN54*, CE | EN54* |
| Input Voltage | 120 Vac (+10%, -15%), 50-60 Hz | | 230 Vac (+10%, -15%), 50-60 Hz | | | |
| Brownout Level | < or = 102 Vac | 96 Vac | < or = 195 Vac | 184 Vac | < or = 195 Vac | 188 Vac |
| Current Requirements | 3-PPS/M included with 3-CPU3 current 3-BBC/M Alarm: 70 mA Standby: 70 mA | Alarm 50mA Standby 50mA | 3-PPS/M-230 included with 3-CPU3 current 3-BBC/M-230 Alarm: 70 mA Standby: 70 mA | Alarm: 50 mA Standby: 50 mA | 3-PPS/M-230-E included with 3-CPU3 current 3-BBC/M-230-E Alarm: 70 mA Standby: 70 mA | Alarm: 50 mA Standby: 50 mA |
| Input Current | 3.0 A | | | 1.5 A | | |
| Total Output Current | Special Applications: 7.0 Amps Regulated: 4.5 Amps total (including internal panel and auxillary outputs). Maximum regulated NAC power via 3-IDC8/4: 1 Amp (see note). | | | | | |
| Battery Charging Capacity | 65 AH Sealed Lead-Acid | None | 65 AH Sealed Lead-Acid | None | 30 AH Sealed Lead-Acid | None |
| Low Battery Trouble | 24 Vdc | | | | 22.5 Vdc | |
| Deep Discharge Cutoff | 19.5 Vdc | | | | 20.0 Vdc | |
| Mounting Requirements | 1 LRM space, 1 chassis footprint | | | | 1 LRM Space + 3-PPS: 2 footprints 3-BBC: 1 footprint | 1 LRM space, 1 chassis footprint |
| Output Voltage | 24 Vdc Nominal | | | | | |
| Auxillary Output Current | Two sources of 3.5 Amps each taken from total output current | | | | | |
| Auxillary Output Terminal Capacity | 18 AWG to 12 AWG (1 mm ² to 2.5 mm ²) | | | | | |
| Output Protection | Electronic power limiting & heat sink temperature | | | | | |
| Ground Fault Detection | < 10K Ohms | | | | | |

Note: Each power supply can support 7 Amps with special application devices. Up to one regulated NAC circuit via 3-IDC8/4 can be supported per 3-PPS power supply. Total power supply current available when supporting a regulated NAC is 4.5 Amps. Maximum regulated NAC current available from the 4.5A supply is 1 Amp.

* EN54-2: (1997) +A1: (2006) Control and Indicating Equipment; EN54-4: (1997) +A1: (2002) +A2: (2006) Power Supply Equipment; EN54-16:(2008) Voice Alarm Control and Indicating Equipment



Contact us...

Email: edwards.fire@fs.utc.com
 Web: www.est-fire.com

EST is an **EDWARDS** brand.
 1016 Corporate Park Drive
 Mebane, NC 27302

In Canada, contact Chubb Edwards...
 Email: inquiries@chubbedwards.com
 Web: www.chubbedwards.com

© 2014 UTC Fire & Security Americas Corporation, Inc. All rights reserved. Specifications subject to change without notice. Edwards is part of UTC Climate, Controls & Security, a unit of United Technologies Corporation.

Ordering Information

| Catalog Number | Description | Ship Wt., lb. (kg) |
|----------------|----------------------------------------------------------------------------------------------------------------------------------------------------------------------------------------------------------------------------------------------------------------------------------------------------------------|--------------------|
| 3-PPS/M | Primary Power Supply w/ local rail module 120V 50/60 Hz | 5 (2.3) |
| 3-BPS/M | Booster Power Supply w/ local rail module 120V 50/60 Hz | 5 (2.3) |
| 3-PPS/M-230 | Primary Power Supply w/ local rail module 230V 50/60 Hz | 5 (2.3) |
| 3-BPS/M-230 | Booster Power Supply w/ local rail module 230V 50/60 Hz | 5 (2.3) |
| 3-PPS/ M-230-E | Primary Power Supply w/local rail module 230V 50 Hz, EN54* Certified, CE. Comes with one EFM-2 and 15 ferrite clamps. | 5 (2.3) |
| 3-BPS/ M-230-E | Booster Power Supply w/local rail module 230V 50 Hz, EN54* Certified, CE | 5 (2.3) |
| 3-BBC/M | Booster/Charger Supply w/local rail module 120V 50/60Hz | 5 (2.3) |
| 3-BBC/M-230 | Booster/Charger Supply w/local rail module 230V 50/60Hz | 5 (2.3) |
| 3-BBC/ M-230-E | Booster/Charger Supply w/local rail module, 230V 50Hz, EN54* Certified, CE | 5 (2.3) |
| 3-BBCMON(-E) | Booster/Charger Monitor Module with charger capability (upgrade 3-BPS/M(-230)(-E) to 3-BBC/M(-230)(-E)) | 5 (2.3) |
| 3-BTSEN | Distribution Module required when battery installed in remote cabinet | .5 (.22) |
| 3-BTSEN-E | Distribution and Temperature Sensor Module. Required in EN54* Markets when battery installed in a remote cabinet. | .5 (.22) |
| EFM-2 | Data filter board, ships with 3-PPS/M-230-E. Provides filtering for network data. For distributed audio applications refer to model EFM-10. Additional ferrite clamp kits may be ordered separately. See European Marketplace Manual P/N 270925 for details on ferrite clamp locations, quantities and wiring. | |
| EFM-10 | Data Filter board order separately for distributed audio. Order one EFM-10 for each node receiving audio in the network. Additional ferrite clamp kits may be ordered separately. See European Marketplace Manual P/N 270925 for details on ferrite clamp locations and quantities. | |
| 7300172 | Ferrite Kit includes 2 ferrites for EN54 applications. | |
| 7300173 | Ferrite Kit includes 15 ferrites for EN54 applications. | |
| 7300174 | Ferrite Kit includes 4 ferrites for EN54 applications. | |
| 7300175 | Ferrite Kit includes 8 ferrites for EN54 applications. | |
| 3-FP | Filler Plate, order separately when no LED or LED/Switch module installed. | 0.1 (0.05) |

* EN54-2: (1997) +A1: (2006) Control and Indicating Equipment; EN54-4: (1997) +A1: (2002) +A2: (2006) Power Supply Equipment; EN54-16:(2008) Voice Alarm Control and Indicating Equipment

[Click Here to Return to Bill of Material/Index](#)