

**NO
EXCUSES!**



As Built Drawings Cabinet

The DBX "AS BUILT DRAWINGS" Cabinet offers the convenience of having building layouts and alarm documents readily accessible for fire departments and other authorized personnel.

This surface mount cabinet is fabricated from 16 gauge steel with a durable, baked on, red textured powder coat finish, white 1" high lettering and features a stainless steel piano hinge and a high security CAT 30 keyed door lock.

Standard Features:

- 16 gauge steel construction
- Durable red textured finish
- White 1" indelible lettering "AS BUILT DRAWINGS"
- Stainless steel piano hinge with CAT 30 keyed door lock
- Surface mount box
- Wall mounting holes

Options:

- Custom finish
- Custom legend
- Custom lock
- Flush Flange

Stainless Steel Piano Hinge

Custom Locks Available

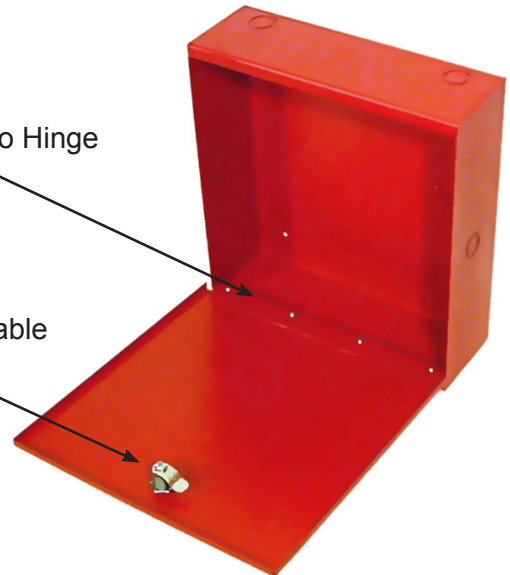

Available in Sizes
AA, A & D

[Click Here to Return to
Bill of Material / Index](#)



ISO 9001
REGISTERED
COMPANY



ACEBOX

Space Age Electronics, Inc.
www.1sae.com
800.486.1723 Toll Free
508.485.0966 Local
508.485.4740 Fax

Specifications:

The DBX As Built Drawings Cabinet is constructed of 16 gauge (.062 thk.) cold rolled steel and finished with a durable red textured, heat-resistant baked-on enamel finish. The front cover includes a durable label displaying "AS BUILT DRAWINGS" in 1" white indelible lettering, applied to the cover relative to the orientation of the installed back box. The front cover features a high security CAT 30 keyed door lock. Custom finish, legend and lock available. Back box universal surface mount design and wall mounting holes.

Size	Dimensions of Cabinet		
	W	H	D
AA	12 1/4"	14 1/4"	4"
A	26 1/4"	14 1/4"	4"
D	26 1/4"	23 5/8"	4"

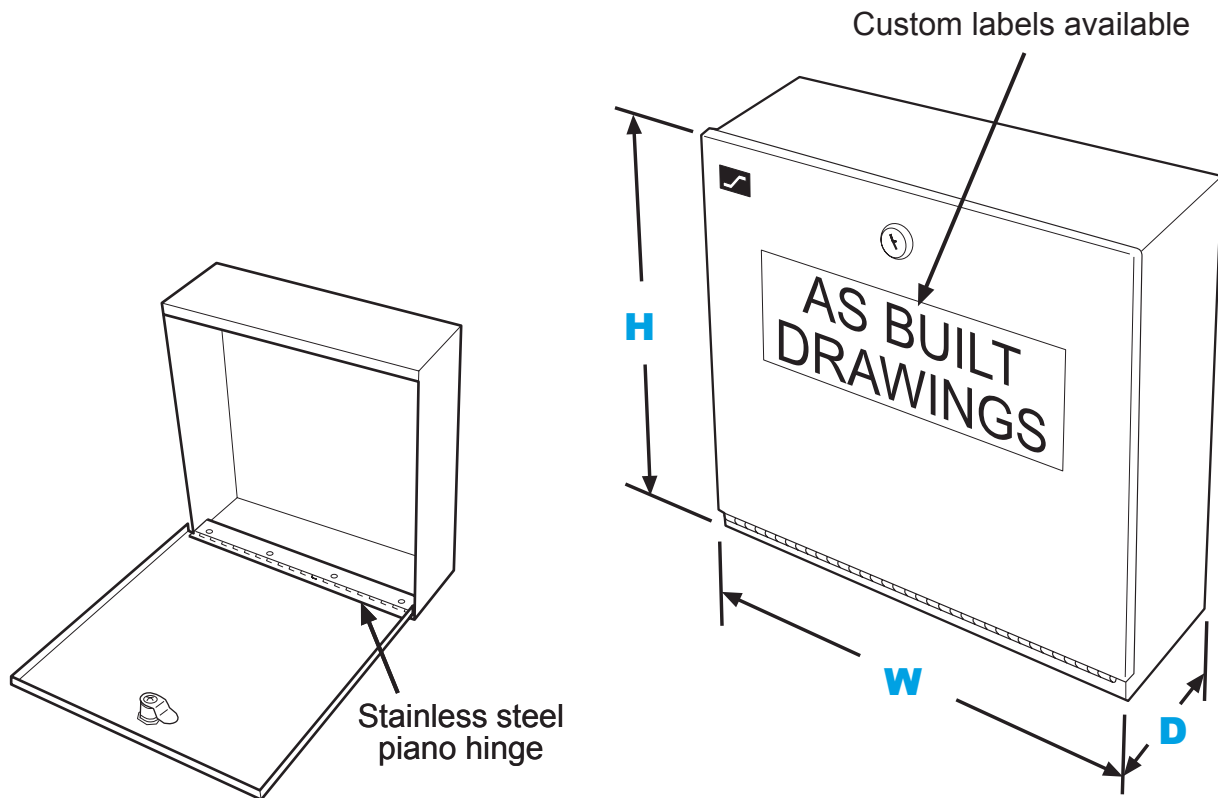

Ordering Information:

Part #	Description
SSU00674	DBXAA As Built Drawings Cabinet, Red
SSU00677	DBXA As Built Drawings Cabinet, Red
SSU00678	DBXD As Built Drawings Cabinet, Red
SSU00680	DBXA Semi Flush Flange, Red
SSU00681	DBXD Semi Flush Flange, Red



Space Age Electronics, Inc.
 www.1sae.com
 800.486.1723 Toll Free
 508.485.0966 Local
 508.485.4740 Fax

No Excuses, Just Solutions!