

- 2 - 2' work table
- 4 - Warming Unit
- 5 - 6' work table
- 6 - Hand wash sink
- 7 - 8' work table
- 8 - Double Door Roll in Refrig.
- 9 - Double Door Reach in Refrig
- 10 - 5' metro shelving (4 racks)



Quote

02/09/2016

To:
 University Of New England
 Dan Roy
 11 HILLS BEACH ROAD
 BIDDEFORD, ME 40050-000
 (207)602-2490
 207-283-0170 (Contact)

Project:
 University Of New England: Armory
 Kitchen
 11 Hills Beach Road
 Biddeford, ME 04005-

From:
 C. Caprara Food Service Equip.
 Chris Caprara
 2214A US Route 202
 Winthrop, ME 04364-0140
 (207)395-2405
 (207)395-2405 1312 (Contact)

Item	Qty	Description	Sell	Sell Total
------	-----	-------------	------	------------

2	2 ea	WORK TABLE Advance Tabco Model No. KMS-240 Work Table, 30"W x 24"D, 16 gauge 304 series stainless steel top with 5"H backplash, 18 gauge stainless steel adjustable undershelf, stainless steel legs with adjustable stainless steel bullet feet, NSF	\$589.00	\$1,178.00
	2 st	TA-25 Casters, 5", swivel, with rubber wheels (set of 4) (2 with brakes)	\$125.00	\$250.00
			ITEM TOTAL:	\$1,428.00







4	2 ea	PROOFER CABINET	\$2,395.00	\$4,790.00
---	------	------------------------	------------	------------

University Of New England: Armory
 Kitchen

University Of New England

Initial: _____
 Page 1 of 4

Item	Qty	Description	Sell	Sell Total
		Metro Model No. C539-CDC-U C5™ 3 Series Heated Holding & Proofing Cabinet, with Red Insulation Armour™, mobile, full height, insulated, dutch clear polycarbonate doors, removable bottom mount control module, thermostat to 200°F, universal wire slides on 3" centers, adjustable on 1-1/2" increments (18) 18" x 26" or (34) 12" x 20" x 2-1/2" pan capacity, 5" casters (two with brakes), aluminum, 120v/60/1-ph, 2000 watts, 16.7 amps, NEMA 5-20P, UL, CUL, NSF	Item 4	
5	1 ea	WORK TABLE Advance Tabco Model No. KMS-306 Work Table, 72"W x 30"D, 16 gauge 304 series stainless steel top with 5"H backsplash, 18 gauge stainless steel adjustable undershelf, stainless steel legs with adjustable stainless steel bullet feet, NSF	\$795.00	\$795.00
	1 st	TA-25 Casters, 5", swivel, with rubber wheels (set of 4) (2 with brakes)	\$125.00	\$125.00
	2 ea	SS-2020 Deluxe Drawer, 20"W x 20"D x 5" deep drawer pan insert, stainless steel, with drawer slides	\$235.00	\$470.00
			ITEM TOTAL:	\$1,390.00
6	1 ea	HAND SINK Advance Tabco Model No. 7-PS-40 Hand Sink, wall model, 14" wide x 10" front-to-back x 5" deep bowl, 20 gauge 304 series stainless steel, 7-3/4" high side splashes, with splash mounted faucet, lever drain with overflow, P-trap, wall bracket, NSF, cCSAus	\$515.00	\$515.00
	1 ea	K-316-LU Wrist Handle Only, for splash or deck mounted hand sink faucet (1 pair hot & cold)	\$45.00	\$45.00
			ITEM TOTAL:	\$560.00
7	2 ea	WORK TABLE Advance Tabco Model No. MS-308 Work Table, 96"W x 30"D, 16 gauge 304 series stainless steel top without splash, 18 gauge stainless steel adjustable undershelf, stainless steel legs with adjustable stainless steel bullet feet, NSF	\$895.00	\$1,790.00
	4 ea	SS-2020 Deluxe Drawer, 20"W x 20"D x 5" deep drawer pan insert, stainless steel, with drawer slides	\$235.00	\$940.00
	3 st	TA-25 Casters, 5", swivel, with rubber wheels (set of 4) (2 with brakes)	\$125.00	\$375.00
			ITEM TOTAL:	\$3,105.00
7.1	1 ea	WORK TABLE Advance Tabco Model No. KMS-308 Work Table, 96"W x 30"D, 16 gauge 304 series stainless steel top with 5"H backsplash, 18 gauge stainless steel adjustable undershelf, stainless steel legs with adjustable stainless steel bullet feet, NSF	\$1,069.00	\$1,069.00
	2 ea	SS-2020 Deluxe Drawer, 20"W x 20"D x 5" deep drawer pan insert, stainless steel, with drawer slides	\$235.00	\$470.00
	1 st	TA-25-6 Casters, 5", swivel, with rubber wheels (set of 6) (3 with brakes)	\$188.00	\$188.00
			ITEM TOTAL:	\$1,727.00
8	1 ea	ROLL-IN REFRIGERATOR	\$5,195.00	\$5,195.00

Item	Qty	Description	Sell	Sell Total
		True Food Service Equipment Model No. STG2RRI-2S SPEC SERIES® Roll-in Refrigerator, stainless steel front, aluminum sides, (2) stainless steel doors with locks, cam-lift hinges, digital temperature control, aluminum interior, incandescent interior lighting, stainless steel ramps, 1/2 HP, 115v/60/1, 11.8 amps, 9' cord, NEMA 5-15P, [accommodates 27"Wx29"Dx66"H carts, NOT included], cULus, NSF, MADE IN USA		
	1 ea	Warranty - 3 year parts and labor, please visit www.Truemfg.com for specifics		
	1 ea	Warranty - 5 year compressor (self-contained only), please visit www.Truemfg.com for specifics		
	1 ea	Left door hinged left, right door hinged right standard		
8.1	2 ea	PAN RACK, BUN Channel Manufacturing Model No. 405AC Bun Pan Rack, economy, mobile, 20-1/2"W x 26"D x 64"H, end load, 2" spacing, capacity (27) 18" x 26" bun pans, aluminum construction, 5" bolted non-marking swivel stem casters, all welded, NSF	\$298.00	\$596.00
				
9	1 ea	REACH-IN REFRIGERATOR True Food Service Equipment Model No. T-49 Refrigerator, Reach-in, two-section, stainless steel doors, stainless steel front, aluminum sides, aluminum interior with stainless steel floor, (6) adjustable PVC-coated wire shelves, interior lighting, 4" castors, 1/3 HP, 115v/60/1, 5.8 amps, 9' cord, NEMA 5-15P, MADE IN USA, cULus, NSF, CE	\$3,100.00	\$3,100.00
				
	1 ea	Self-contained refrigeration standard		
	1 ea	Warranty - 5 year compressor (self-contained only), please visit www.Truemfg.com for specifics		
	1 ea	4" Swivel castors, standard (adds 5" to OA height)		
	1 ea	Warranty - 3 year parts and labor, please visit www.Truemfg.com for specifics		
	1 ea	Left door hinged left, right door hinged right standard		
10	8 ea	WIRE SHELVING Olympic Model No. J2460K Packed 2 ea Shelf, wire, 24" x 60", green epoxy finish with chromate substrate, NSF	\$49.00	\$392.00
				
	8 ea	J74UK Post 74", mobile, works with stem caster, grooved at 1" intervals, green epoxy finish with chromate substrate, NSF	\$12.00	\$96.00
	4 ea	J5 Stem/Swivel Caster, 5" dia., 1-1/4" face, resilient rubber tread, 200 lb. load capacity (priced per each), NSF	\$15.00	\$60.00
	4 ea	J5B Stem/Swivel-Brake Caster, 5" dia., 1-1/4" face, resilient rubber tread, 200 lb. load capacity (priced per each), NSF	\$18.00	\$72.00
ITEM TOTAL:				\$620.00
Total				\$52,879.00



STAINLESS STEEL
WORK TABLES
STANDARD Series - 5" Backsplash - Undershef Style



Item #: _____ **Qty #:** _____
Model #: _____
Project #: _____

FEATURES:

Top is furnished with a 1 5/8" sanitary rolled rim edge on front, 1 5/8" square side edges, and a 5" splash with a 1" return on the rear side.

TWO hat channels stud welded to reinforce and maintain a level working surface. 30" and 36" wide tables supplied with THREE hat channels.

Pre-engineered welded angle adapters insure ease of future drawer installation.

Aluminum die cast "leg-to-shelf" clamp secures shelf to leg eliminating unsightly nuts and bolts. Undershef is adjustable.

CONSTRUCTION:

All TIG welded. Exposed weld areas polished to match adjacent surfaces.

Entire top mechanically polished to a satin finish.

Top is sound deadened.

Roll formed embossed galvanized hat channels are secured to top by means of structural adhesive and weld studs.

Gussets welded to support hat sections.



NEW
Rolled Rim Edges on Front & Splash on Back and Square Side Edges

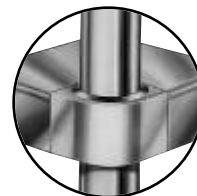

Featuring as Standard:
"THE PROVEN"
ORIGINAL ADVANCE TABCO
Adjustable Undershef with Die Cast Leg Clamp

MATERIAL:

KMS-SERIES: Stainless Steel Legs & Undershef

TOP: 16 gauge stainless steel type "304" series.

SHELF: 18 gauge stainless steel.

LEGS: 1 5/8" diameter tubular stainless steel.
1" adjustable stainless steel bullet feet.
Stainless steel gussets.

KMG-SERIES: Galvanized Legs & Undershef

TOP: 16 gauge stainless steel type "304" series.

SHELF: 18 gauge galvanized steel.

LEGS: 1 5/8" diameter tubular galvanized steel.
1" adjustable plastic bullet feet.
Galvanized steel gussets.

**KMS-Series:
Stainless Steel Legs & Undershef**

L	24" Wide	30" Wide	36" Wide
30"	KMS-240	KMS-300	
24"	KMS-242	KMS-302	
36"	KMS-243	KMS-303	KMS-363
48"	KMS-244	KMS-304	KMS-364
60"	KMS-245	KMS-305	KMS-365
72"	KMS-246	KMS-306	KMS-366
84"	KMS-247	KMS-307	KMS-367
96"	KMS-248	KMS-308	KMS-368
108"	KMS-249	KMS-309	KMS-369
120"	KMS-2410	KMS-3010	KMS-3610
132"	KMS-2411	KMS-3011	KMS-3611
144"	KMS-2412	KMS-3012	KMS-3612

**KMG-Series:
Galvanized Steel Legs & Undershef**

L	24" Wide	30" Wide	36" Wide
30"	KMG-240	KMG-300	
24"	KMG-242	KMG-302	
36"	KMG-243	KMG-303	KMG-363
48"	KMG-244	KMG-304	KMG-364
60"	KMG-245	KMG-305	KMG-365
72"	KMG-246	KMG-306	KMG-366
84"	KMG-247	KMG-307	KMG-367
96"	KMG-248	KMG-308	KMG-368
108"	KMG-249	KMG-309	KMG-369
120"	KMG-2410	KMG-3010	KMG-3610
132"	KMG-2411	KMG-3011	KMG-3611
144"	KMG-2412	KMG-3012	KMG-3612



Create Your Own Efficient Workstation with the Available Standard Accessories (Visit Section K)



Customer Service Available To Assist You 1-800-645-3166 8:30 am - 8:00 pm E.S.T.

Email Orders To: customer@advancetabco.com. For Smart Fabrication™ Quotes, Email To: smartfab@advancetabco.com or Fax To: 631-586-2933

NEW YORK
Fax: (631) 242-6900

GEORGIA
Fax: (770) 775-5625

TEXAS
Fax: (972) 932-4795

NEVADA
Fax: (775) 972-1578

DETAILS and SPECIFICATIONS

ALL DIMENSIONS ARE TYPICAL TOL ± .500"

All Units Shipped Unassembled (KD) for Reduced Shipping Costs.

KMS & KMG Series Undershelf Style 5" Backsplash

Finished size of undershelf = Length minus 5 3/4"
Width minus 5 3/4"

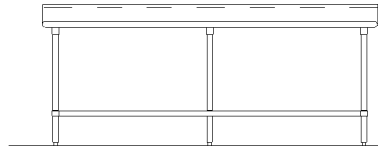

Units 8ft. and larger are furnished with six (6) legs

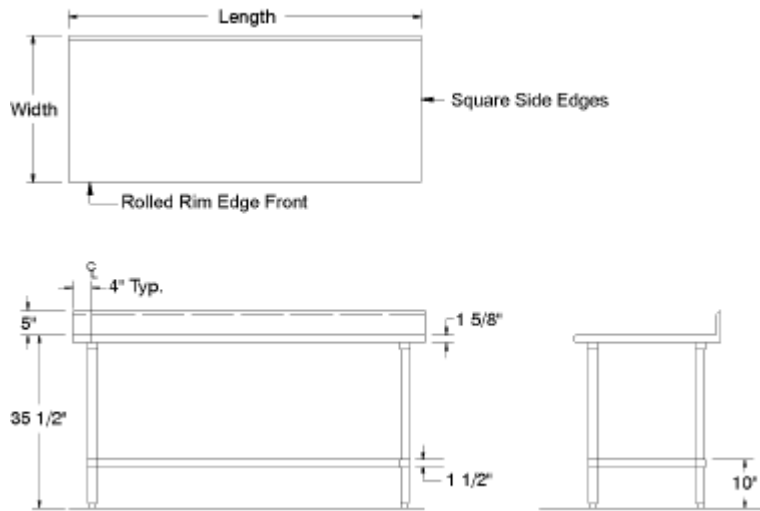

KMS-Series: Stainless Steel Legs & Undershelf

L	24" Wide	Wt.	30" Wide	Wt.	36" Wide	Wt.
30"	KMS-240	55 lbs.	KMS-300	70 lbs.		
24"	KMS-242	50 lbs.	KMS-302	56 lbs.		
36"	KMS-243	66 lbs.	KMS-303	77 lbs.	KMS-363	92 lbs.
48"	KMS-244	81 lbs.	KMS-304	92 lbs.	KMS-364	101 lbs.
60"	KMS-245	95 lbs.	KMS-305	111 lbs.	KMS-365	121 lbs.
72"	KMS-246	113 lbs.	KMS-306	129 lbs.	KMS-366	142 lbs.
84"	KMS-247	135 lbs.	KMS-307	153 lbs.	KMS-367	169 lbs.
96"	KMS-248	150 lbs.	KMS-308	171 lbs.	KMS-368	189 lbs.
108"	KMS-249	165 lbs.	KMS-309	195 lbs.	KMS-369	260 lbs.
120"	KMS-2410	268 lbs.	KMS-3010	294 lbs.	KMS-3610	315 lbs.
132"	KMS-2411	301 lbs.	KMS-3011	331 lbs.	KMS-3611	358 lbs.
144"	KMS-2412	316 lbs.	KMS-3012	346 lbs.	KMS-3612	373 lbs.

KMG-Series: Galvanized Steel Legs & Undershelf

L	24" Wide	Wt.	30" Wide	Wt.	36" Wide	Wt.
30"	KMG-240	55 lbs.	KMG-300	70 lbs.		
24"	KMG-242	50 lbs.	KMG-302	56 lbs.		
36"	KMG-243	66 lbs.	KMG-303	77 lbs.	KMG-363	92 lbs.
48"	KMG-244	81 lbs.	KMG-304	92 lbs.	KMG-364	101 lbs.
60"	KMG-245	95 lbs.	KMG-305	111 lbs.	KMG-365	121 lbs.
72"	KMG-246	113 lbs.	KMG-306	129 lbs.	KMG-366	142 lbs.
84"	KMG-247	135 lbs.	KMG-307	153 lbs.	KMG-367	169 lbs.
96"	KMG-248	150 lbs.	KMG-308	171 lbs.	KMG-368	189 lbs.
108"	KMG-249	165 lbs.	KMG-309	195 lbs.	KMG-369	260 lbs.
120"	KMG-2410	268 lbs.	KMG-3010	294 lbs.	KMG-3610	315 lbs.
132"	KMG-2411	301 lbs.	KMG-3011	331 lbs.	KMG-3611	358 lbs.
144"	KMG-2412	316 lbs.	KMG-3012	346 lbs.	KMG-3612	373 lbs.



ADVANCE TABCO is constantly engaged in a program of improving our products. Therefore, we reserve the right to change specifications without prior notice.



Item # _____

Job _____

Metro C5 3 Series Insulation Armour™ Heated Holding and Proofing Cabinets

- **Insulation Armour™:** Patented insulation technology retains heat, saves energy, and provides a cool-to-touch exterior. Durable polymer construction is dent, impact, and stain resistant. Molded-in hand holds create vertical handles for mobile applications.
- **Colors:** Insulation Armour is available in Red, Blue, or Gray standard and in other colors on a promotional basis or upon request.
- **Control:** Three modules are available: Holding, Moisture, and Combination Proof and Hold. All feature an easy-to-read digital thermometer, recessed control dials, a master on/off switch, and power indicator lights. All are removable without tools for easy cleaning, and allow for future upgrades without replacing entire cabinet body.
- **Performance:** All modules provide fast heat-up and recovery through a thermostatically controlled, forced convection system.
- **Sizes:** C5 3 Series cabinets are available in Full Height (71", 1803mm), ¾ Height (59", 1499mm), and ½ Height (44", 1118mm) sizes.
- **Doors:** Solid insulated aluminum or clear polycarbonate doors are available. Full Height cabinets can be configured with full length or dutch-style doors. Clear doors provide visibility of the contents of the cabinet without the heat loss associated with opening the door.
- **Capacity:** Three slide styles provide maximum holding capacity. Choose from Universal Wire, Lip Load, or Fixed Wire.
- **Reliability:** Reliability and durability are designed into every C5. High-quality components provide a long life of worry free use.
- **Power Options:** Choose between standard high wattage or low wattage models based on the specific needs of the application.



Red Full
Height Dutch
Clear Doors



Blue ½
Height Full
Solid Door

Gray ¾
Height Full
Clear Door

Red Full
Height Dutch
Solid Doors

Blue Full
Height Full
Clear Door

METRO
C5
C5 3 Series Insulation Armour™ Heated Holding and Proofing Cabinets

13-93



3 Series Removable Control Modules

- **Holding Module:** Hot holding at higher temperatures without moisture control.
- **Moisture Module:** Hot holding and proofing. Moisture control at any temperature.
- **Combination Module:** Hot holding and proofing. Moisture control at lower temperatures (proofing).



InterMetro Industries Corporation
North Washington Street
Wilkes-Barre, PA 18705
www.metro.com



13.93



C5 3 Series Insulation Armour™ Heated Holding and Proofing Cabinets

Specifications

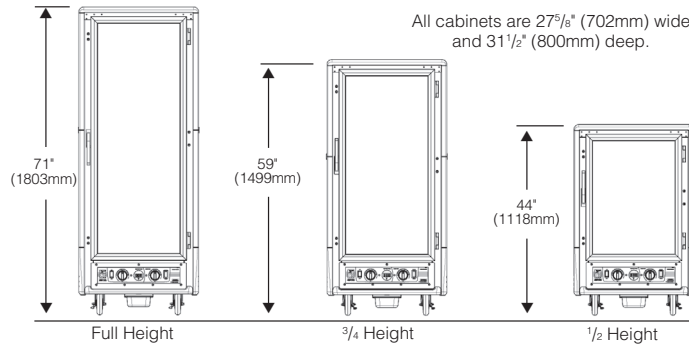

- Cabinet Material:** .063" (1.8mm) aluminum, natural interior with .125" (3.2mm) aluminum chassis.
 - Insulation Armour™:** High Density Polyethylene (HDPE).
 - Casters:** Four casters with 5" (127mm) donut neoprene wheel, double ball bearing swivel, ball bearing axel, nickel plated, two with brake.
 - Solid Doors:** Fully insulated with 1" (25.4mm) fiberglass, double panel .063" (1.8mm) aluminum, brushed exterior, natural interior.
 - Clear Doors:** Extruded aluminum powder coated frame with .090" (2.3mm) polycarbonate window.
 - Hinges:** Field reversible, double hinged, 180° swing, with long-life nylon bearings.
 - Gaskets:** High temperature, door mounted, Santoprene gaskets.
 - Latches:** Polymer high-strength magnetic pull latch with lever-action release.
 - Hand Holds:** Molded into the Insulation Armour™ on all four corners.
 - Universal Slides:** 1/4" (6.4mm) dia. nickel-chrome electroplated wire, adjustable on 1 1/2" (38mm) increments.
 - Lip Load Slides:** 1 1/2"x1/2"x.063" (38x38x1.8mm) extruded aluminum channel slides, 1 1/2" (38mm) fixed spacing.
 - Fixed Wire Slides:** 1/4" (6.4mm) dia. nickel-chrome electroplated wire, welded on 3" (76mm) spacing.
 - Drip Trough:** Smooth polymer drip trough with catch pan.
 - Holding Modules:** Removable without tools, digital thermometer, recessed control dials, master on/off switch, "Power On" light, water pan, ball bearing blower forced air system, 7 1/2' cord, UL, CUL, and NSF Listed.
- Electrical and Performance:**
- Holding Module:** 2000 Watt, 120 Volts, 60 Hz., single phase, 16.7 Amps. 80°F to 200°F operating temperature range. NEMA 5-20P plug.
 - Moisture Module:** 2000 Watt, 120 Volts, 60 Hz., single phase, 16.7 Amps. 80°F to 200°F operating temperature range. 35% RH at 160°F, 95% RH at 95°F. NEMA 5-20P plug.
 - Proofing Module:** 1440 Watt, 120 Volts, 60 Hz., single phase, 12 Amps. 80°F to 120°F operating temperature range. 95% RH at 95°F. NEMA 5-15P plug.
 - Combination Module:** 2000 Watt, 120 Volts, 60 Hz., single phase, 16.7 Amps. 80°F to 200°F operating temperature range. 95% RH at 95°F. NEMA 5-20P plug.
 - Clearance Requirements:** 18" (46cm) away from any cooking equipment. AVOID contact with surfaces that exceed 200°F (90°C). Minimum clearance from enclosures is 1 1/2" (38mm) on sides, back and top.
- Slide Capacities:**

Cabinet Size	Universal Wire Pan Capacity**				Lip Load Pan Capacity		Fixed Wire Pan Capacity	
	Slide Pairs		18"x26"	12"x20"x2.5" GN 1/1	18"x26"	18"x26"	12"x20"x2.5" GN 1/1	
Provided	Max.*	18"x26"						12"x20"x2.5" GN 1/1
Full Height	18	37	18	34	35	18	34	
Full Height Dutch	18	35	17	32	34	17	32	
3/4 Height	14	29	14	26	27	14	26	
1/2 Height	8	17	8	16	17	8	16	

*Maximum number of slide pairs @ 1 1/2" spacing. Additional slide pairs ordered separately.
**Capacity based on standard number of slide pairs provided.

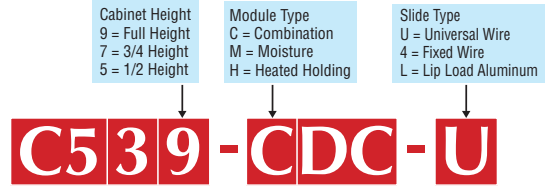

NEMA 5-20P
For Standard Wattage Cabinets (120V, 16A, 60Hz, 2000W)

Door Style
FS = Full Length Solid DS = Dutch Solid *
FC = Full Length Clear DC = Dutch Clear *

*Please note: Dutch doors only available on full-height models.
Cabinets ordered without a color designation default to Red.

Low Watt Model Number Description

C539 - CLDC - U

NEMA 5-15P Add "L" for Lower Wattage Combination or Holding Module Cabinets (120V, 12A, 60Hz, 1440W)

Export Model Number Description

C539 - CXDC - U

NEMA 6-15P Add "X" for Export Cabinets (220-240V, 7.6-8.3A, 50/60Hz, 1681-2000W)

Blue or Gray Model Description

C539 - CDC - U - BU

** Cabinets ordered without a color designation default to Red.

Color **
No Suffix = Red
BU = Blue
GY = Gray

Models with Accessories or Options

C539 - CDC - UA
C539 - CDC - U - BUA

An "A" suffix indicates that accessories need to be factory assembled to the cabinet. Order accessories separately.

Options/Accessories*

- Small Item Shelf (C5-SHELF-S)
- Stainless Steel Legs (C5-SSLEGS)
- Universal Slide Pair, Chrome (C5-USLIDEP-R)
- 6" Casters (C5-6CASTER)
- Rear Rigid Casters (C5-5RDGCSTR)
- Travel Latch (C5-TRVL)
- Flush Door Latch (C5-LATCHFLUSH-1)*
- Straight Plug, 20 Amp, 120V (C5-STRPLG-20)
- Straight Plug, 15 Amp, 120V (C5-STRPLG-15)
- Factory Left-Hand Hinging (DD3768)
- Stainless Steel Universal Slides (please call)

*Please note: (2) handles required for dutch door models

Metro Heated cabinets are for hot food holding applications only.

All Metro Catalog Sheets are available on our website: www.metro.com



InterMetro Industries Corporation

North Washington Street • Wilkes-Barre, PA 18705 • 570.825.2741
Fax: 800.638.9263 (East Coast/Canada) • Fax: 800.638.3292 (West Coast)

FOR PRODUCT INFORMATION/CUSTOMER SERVICE:
U.S./Canada/Latin America: 1.800.992.1776 • Europe: +31.76.587.7550
Asia/Pacific: +65.6567.8003 • Middle East/Africa: +971.4.811.8286

Information and specifications are subject to change without notice. Please confirm at time of order

Copyright © 2012 InterMetro Industries Corp.

L03-270
Rev. 05/12
Printed in U.S.A.

C5 3 Series Insulation Armour™ Heated Holding and Proofing Cabinets





DELUXE AND BUDGET DRAWERS



- Stainless Steel Front
- Ball Bearing Slides
- Removable Insert

Item #: _____ Qty #: _____
 Model #: _____
 Project #: _____

MODEL #	Type	Length	Width	Insert
SS-2015	Stainless Steel	21 1/2"	17 3/4"	20" x 15" x 5"
GZ-2015	Galvanized	21 1/2"	17 3/4"	20" x 15" x 5"
SS-2020	Stainless Steel	21 1/2"	22 3/4"	20" x 20" x 5"
GZ-2020	Galvanized	21 1/2"	22 3/4"	20" x 20" x 5"
SS-1520	Stainless Steel	17 3/4"	21 1/2"	15" x 20" x 5"
GZ-1520	Galvanized	17 3/4"	21 1/2"	15" x 20" x 5"

DELUXE AND BUDGET DRAWER ACCESSORIES

Padlockable Drawer Lock TA-13
 (Does not include lock. Fits padlocks up to 3/8" Dia. lock shaft)

Keyed Drawer Lock TA-14
 (Does not apply to Budget Drawers)

Drawer Adapter/Non Catalog Tables
 (Specify table width) TA-90



- Friction Slides
- Die Formed Handle

MODEL #	Type	Length	Width	Insert
FS-2015	Stainless Steel	21 1/2"	17 3/4"	20" x 15" x 5"
FG-2015	Galvanized	21 1/2"	17 3/4"	20" x 15" x 5"
FS-2020	Stainless Steel	21 1/2"	22 3/4"	20" x 20" x 5"
FG-2020	Galvanized	21 1/2"	22 3/4"	20" x 20" x 5"
FS-1520	Stainless Steel	17 3/4"	21 1/2"	15" x 20" x 5"
FG-1520	Galvanized	17 3/4"	21 1/2"	15" x 20" x 5"

DELUXE SERIES DRAWERS DETAILS and SPECIFICATIONS

TOL ± .500"

ALL DIMENSIONS ARE TYPICAL

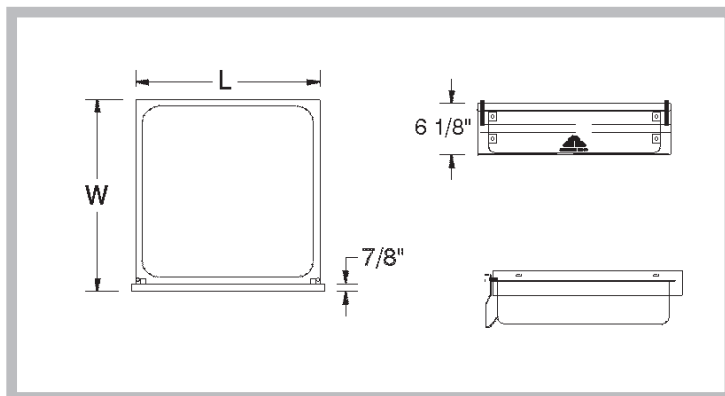

BUDGET SERIES DRAWERS DETAILS and SPECIFICATIONS

TOL ± .500"

ALL DIMENSIONS ARE TYPICAL

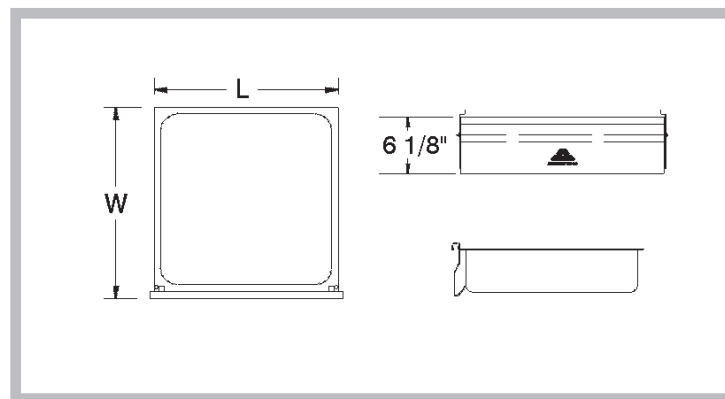

Customer Service Available To Assist You **1-800-645-3166** 8:30 am - 8:00 pm E.S.T.

Email Orders To: customer@advancetabco.com. For Smart Fabrication™ Quotes, Email To: smartfab@advancetabco.com or Fax To: 631-586-2933

NEW YORK
 Fax: (631) 242-6900

GEORGIA
 Fax: (770) 775-5625

TEXAS
 Fax: (972) 932-4795

NEVADA
 Fax: (775) 972-1578



STAINLESS STEEL
HAND SINKS
SIDE SPLASH UNITS



Keyhole Bracket for easier installation and greater stability.



Item #: _____ Qty #: _____
Model #: _____
Project #: _____



7-PS-40



7-PS-66
7-PS-66-NF (Faucet Not Included)

STANDARD FEATURES:

One piece **Deep Drawn** sink bowl design.
Sink bowl is 10" x 14" x 5".
Keyhole wall mount bracket.
Stainless steel basket drain 1-1/2" IPS.
Splash mounted 4" O.C. gooseneck faucet furnished with aerator.

7-PS-40 & 7-PS-66 Series Specific Features:

Welded 7 3/4" high side splashes.
7-PS-66W includes K-316 Wrist Handle Faucet
7-PS-40 lever operated drain and built-in overflow with plastic overflow tube and spring clamps. P-Trap is 1 1/2" IPS.

7-PS-56 Specific Features:

Space Saver Sink bowl is 9" x 9" x 5".
7 3/4" high side splashes.
Flat-Top Strainer 1-1/2" IPS.

7-PS-76 Specific Features:

12" high side splashes.
Includes 17 1/4" x 3" x 2 5/16" Full length removable Utility Tray for use with 12" Side Splash Units.
Lever operated drain and built-in overflow with plastic overflow tube and spring clamps. P-Trap is 1 1/2" IPS.

7-PS-87 Specific Features:

Same features as 7-PS-40 Plus C-Fold Paper Towel & Soap Dispenser.

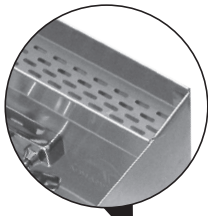

Includes Removable Rear Utility Tray



7-PS-66W



7-PS-76



7-PS-66L (Shown)
or 7-PS-66R

CONSTRUCTION:

All TIG welded.
Welded areas blended to match adjacent surfaces and to a satin finish.
Die formed Countertop Edge with a 3/8" No-Drip offset.
One sheet of stainless steel - No Seams.
All sink bowls have a large liberal radii with a minimum dimension of 2" and are rectangular in design for increased capacity.

MATERIAL:

Heavy gauge type 304 series stainless steel.
Wall mounting bracket is galvanized and of offset design.
All fittings are brass / chrome plated unless otherwise indicated.

MECHANICAL:

Faucet supply is 1/2" IPS male thread hot and cold.



7-PS-87



7-PS-56 **SPACE SAVER**
9" x 9" x 5" Bowl

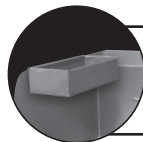

REMOVABLE UTILITY TRAY 7-PS-48
8" x 3" x 2 5/16" Tray - Tray hem allows to hang from any standard side splash. Perforated for water drainage.

Faucets Are AB1953 Lead Free Compliant.

For Replacement Faucets & Upgrades, Drains & Accessories
Visit our website at www.advancetabco.com



Customer Service Available To Assist You **1-800-645-3166** 8:30 am - 8:00 pm E.S.T.

For Orders & Customer Service:

Email: customer@advancetabco.com or Fax: 631-242-6900

For Smart Fabrication™ Quotes:

Email: smartfab@advancetabco.com or Fax: 631-586-2933

DIMENSIONS and SPECIFICATIONS

TOL Overall: ± .500" Interior: ± .250"

FITTINGS SUPPLIED AS SHOWN

ALL DIMENSIONS ARE TYPICAL

7-PS-40, 7-PS-66, 7-PS-66-NF, 7-PS-66W & 7-PS-66RorL
 (7-PS-66 Series Excludes P-Trap & Lever Drain)

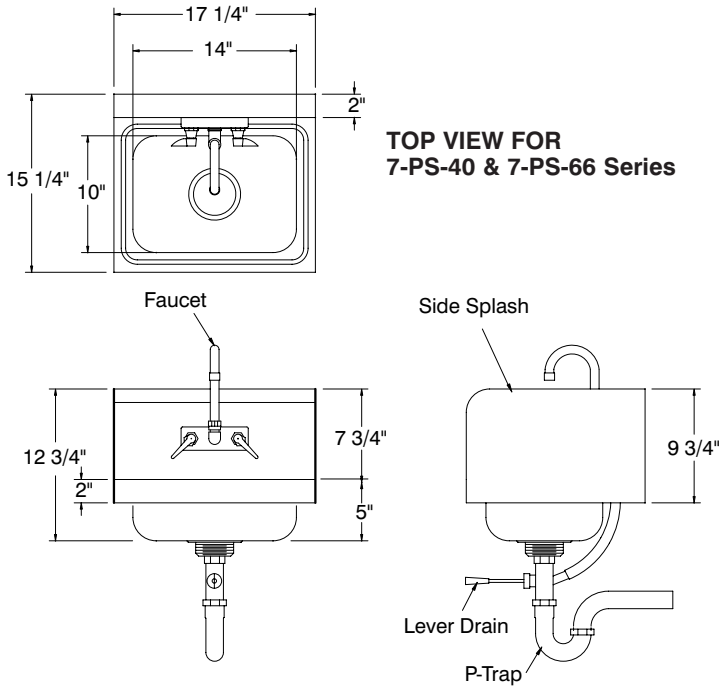

7-PS-40 - 22 lbs. 7-PS-66W - 22 lbs.
 7-PS-66 - 19 lbs. 7-PS-66RorL - 20 lbs.
 7-PS-66-NF - 19 lbs.

7-PS-56

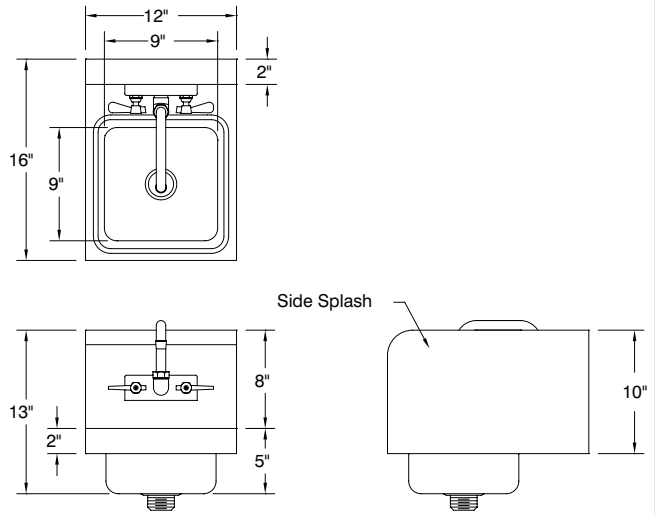

14 lbs.

7-PS-76

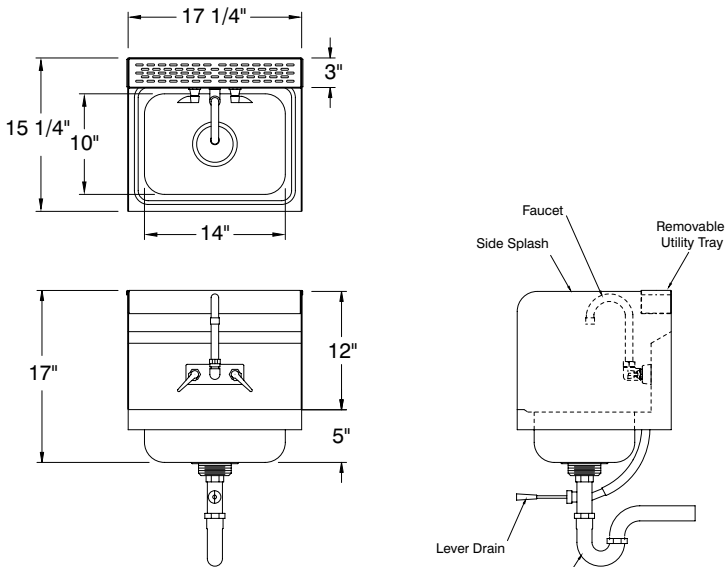

27 lbs.

7-PS-87

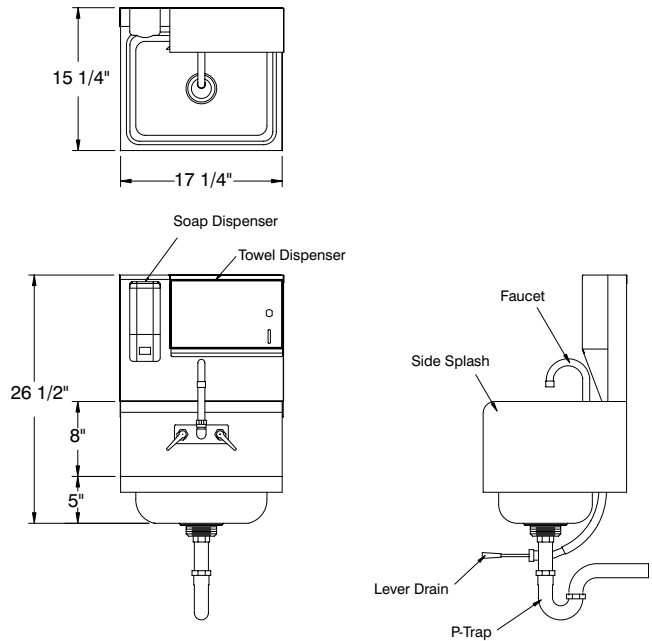

34 lbs.



ADVANCE TABCO is constantly engaged in a program of improving our products. Therefore, we reserve the right to change specifications without prior notice.

MODS & ACCESSORIES

Underbar Modifications & Accessories

UNDERBAR ACCESSORIES

A-1 Perforated Cover for Sink Bowl



A-8 Shown

- A-8** 5 Compartment Condiment Rack
(Hangs On Backsplash Of Ice Bin)
- A-46** 4" Swivel Stem Casters (Set of 4 - 2 w/ Brakes)
- D-12** Replacement Cover For D-12 Series
- D-24** Replacement Cover For D-24 Series
- K-12** Replacement Deck Mounted Soap Dispenser
- SU-55** Removable Stainless Steel Divider For Beer Box

UNDERBAR MODIFICATIONS

- A-51** 6" Hole In Drainboard Surface
(Waste Chute Installation)
- PR-STRAP** Stainless Steel Straps For Speed Rails
(Set of 2 - For KS-2K Speed Rail Only)
- SU-10A** Upgrade To S/S Legs & Bullet Feet
(18" Legs - Includes Front-to-Back Cross-Bracing)
- SU-10B** Upgrade To S/S Legs & Bullet Feet
(10" Legs - Includes Front-to-Back Cross-Bracing)
- SU-10C** Upgrade To S/S Legs & Bullet Feet
(14" Legs - Includes Front-to-Back Cross-Bracing)
- SU-18R or L** Right or Left Side Splash for 18" Wide Unit
- SU-18RL** Right & Left Side Splash for 18" Wide Unit
- SU-21R or L** Right or Left Side Splash for 21" Wide Unit
- SU-21RL** Right & Left Side Splash for 21" Wide Unit
- SU-22** Add 10"x14"x10" Sink To Drbd. Cabinet
(Includes Splash Mt. Faucet)
- SU-24** Connect 18" & 21" Wide Units In Factory
- SU-30** Soda Chase Provision - Tip-Out
(For Ice Bins w/ Backsplash Only)
- SU-36** Add Waste Chute (Blender Stations Only)
- SU-40** Prep Unit For Installation Of Speed Rails
- SU-41** Make Speed Rail An Odd Length
- SU-42** Make Speed Rail Accommodate
1/2 Gallon Bottles
- SU-61** Special Sizing For Ice Bins
- SU-68** Omit Corrugation On Drainboards

PERFORATED BASKETS FOR UNDERBAR SINKS



A-16

Fits 10" x 14" x 10" Sink



A-17

Fits 9 1/2" x 11 1/2" x 6" Sink



A-23

Fits 6" x 11" x 6" Sink

REMOVABLE BLACK PLASTIC BOTTLE RACKS



A-19

Single Bottle Rack
5 1/4" x 5 1/4"



A-20

3-Pack Bottle Rack
(6 per Case)
5 1/4" x 15 7/8"



A-18

4-Pack Bottle Rack
5" x 16 1/2"

STAINLESS STEEL FALSE BOTTOM



- A-41** For 24" Ice Bin
- A-42** For 30" Ice Bin
- A-43** For 36" Ice Bin
- A-44** For 42" Ice Bin
- A-45** For 48" Ice Bin

SLIDING STAINLESS STEEL COVER



- SSC-12** For 12" Ice Bin
- SSC-15** For 15" Ice Bin
- SSC-24** For 24" Ice Bin
- SSC-30** For 30" Ice Bin
- SSC-36** For 36" Ice Bin
- SSC-42** For 42" Ice Bin
- SSC-48** For 48" Ice Bin
- SSC-PT** For Pass-Thru Ice Bin

STAINLESS STEEL ICE BIN PARTITION



14 3/4"
Wide

- A-38** 8" High
- A-39** 11" High
- A-40** 15" High



A-24

8" x 8" Add-On Blender Shelf
w/ Duplex Outlet Hidden Beneath Shelf



K-316-LU

Add Wrist Handles
For Deck Or Splash Mt. Faucets



Customer Service Available To Assist You 1-800-645-3166 8:30 am - 8:00 pm E.S.T.

For Orders & Customer Service:

Email: customer@advancetabco.com or Fax: 631-242-6900

For Smart Fabrication™ Quotes:

Email: smartfab@advancetabco.com or Fax: 631-586-2933

FAUCETS

Underbar Equipment Faucets

UNDERBAR DECK MOUNTED SINK FAUCETS

6" Deck Mounted Faucet



K-51 4" O.C.

3-1/2" Gooseneck



K-52 4" O.C.

12" Swing Spout



K-53 4" O.C.

Water Filler Faucet



K-54 4" O.C.

Deck Mt. 6" Extended Spout 4" O.C.



K-124

K-208 With Wrist Handles

Dipper Well Faucet



A-33

Gooseneck Deck Mount Melt Down Nozzle 4" O.C.

A-29 A-30 (Installed)



UNDERBAR SPLASH MOUNTED SINK FAUCETS

3-1/2" Splash Mounted Faucet



K-59 4" O.C.

Extra Heavy Duty Splash Mounted Faucet



K-69 4" O.C.

Splash Mt. 6" Extended Spout 4" O.C.

K-123



Splash Mt. 6" Extended Spout with Wrist Handles



K-206 4" O.C.

6" Splash Mounted Faucet



K-125 4" O.C.

10" Splash Mounted Spout



K-126 4" O.C.

Wrist Handles for Faucets

K-316-LU



UNDERBAR SINK ACCESSORIES

WASTE OUTLETS & CHUTES

1" Waste Outlet



A-10 (6 per carton)

1-1/2" Waste Outlet



A-11 (6 per carton)

5-1/2" Stainless Steel Open Waste Chute



A-6

Factory Installed

Stainless Steel Liquid Waste Chute



A-7

Factory Installed

STAINLESS STEEL OVERFLOW PIPES



1" Pipe (6 per carton)

A-12



1-1/2" Pipe (6 per carton)

A-13

Replacement Rubber Grommets For Overflow Pipes

1" Grommet (12 per carton)

A-21



1-1/2" Grommet (12 per carton)

A-22



SOAP DISPENSERS & HOLDERS

Deck Mounted Soap Dispenser

K-12



Chrome Towel Ring (Packed Loose)

A-15



ADVANCE TABCO is constantly engaged in a program of improving our products. Therefore, we reserve the right to change specifications without prior notice.

© ADVANCE TABCO, JULY 2015



STAINLESS STEEL
WORK TABLES
STANDARD Series - Flat Top - UNDERSHELF Style



Item #: _____ **Qty #:** _____
Model #: _____
Project #: _____

FEATURES:

Top is furnished with 1-5/8" sanitary rolled rim edges on front & back and square side edges.

To reinforce and maintain a level working surface, 24" wide tables are supplied with TWO hat channels and 30" and 36" wide tables are supplied with THREE hat channels.

Pre-engineered welded angle adapters insure ease of future drawer installation.

Aluminum die cast "leg-to-shelf" clamp secures shelf to leg eliminating unsightly nuts & bolts. Undershelf is adjustable.

CONSTRUCTION:

All TIG welded. Exposed weld areas polished to match adjacent surfaces.

Entire top mechanically polished to a satin finish.

Top is sound deadened.

Roll formed embossed galvanized hat channels are secured to top by means of structural adhesive and weld studs.

Gussets welded to support hat sections.



NEW
 Rolled Rim Edges on
 Front & Back and
 Square Side Edges

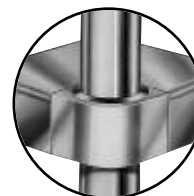

Featuring as Standard:
"THE PROVEN"
 ORIGINAL ADVANCE TABCO
**Adjustable Undershelf
 with Die Cast Leg Clamp**

MATERIAL:

MS-SERIES: Stainless Steel Legs & Undershelf

- TOP:** 16 gauge stainless steel type "304" series.
- SHELF:** 18 gauge stainless steel.
- LEGS:** 1 5/8" diameter tubular stainless steel.
 1" adjustable **stainless steel** bullet feet.
 Stainless steel gussets.

MG-SERIES: Galvanized Legs & Undershelf

- TOP:** 16 gauge stainless steel type "304" series.
- SHELF:** 18 gauge galvanized steel.
- LEGS:** 1 5/8" diameter tubular galvanized steel.
 1" adjustable plastic feet.
 Galvanized steel gussets.

MS-Series:

Stainless Steel Legs & Undershelf

L	24" Wide	30" Wide	36" Wide
30"	MS-240	MS-300	
24"	MS-242	MS-302	
36"	MS-243	MS-303	MS-363
48"	MS-244	MS-304	MS-364
60"	MS-245	MS-305	MS-365
72"	MS-246	MS-306	MS-366
84"	MS-247	MS-307	MS-367
96"	MS-248	MS-308	MS-368
108"	MS-249	MS-309	MS-369
120"	MS-2410	MS-3010	MS-3610
132"	MS-2411	MS-3011	MS-3611
144"	MS-2412	MS-3012	MS-3612



MG-Series:

Galvanized Steel Legs & Undershelf

L	24" Wide	30" Wide	36" Wide
30"	MG-240	MG-300	
24"	MG-242	MG-302	
36"	MG-243	MG-303	MG-363
48"	MG-244	MG-304	MG-364
60"	MG-245	MG-305	MG-365
72"	MG-246	MG-306	MG-366
84"	MG-247	MG-307	MG-367
96"	MG-248	MG-308	MG-368
108"	MG-249	MG-309	MG-369
120"	MG-2410	MG-3010	MG-3610
132"	MG-2411	MG-3011	MG-3611
144"	MG-2412	MG-3012	MG-3612

Create Your Own Efficient Workstation with the Available Standard Accessories (Visit Section K)



NEW YORK
 (800) 645-3166
 Fax: (631) 242-6900

GEORGIA
 (800) 832-1218
 Fax: (770) 775-5625

TEXAS
 (800) 527-0353
 Fax: (972) 932-4795

NEVADA
 (800) 446-8684
 Fax: (775) 972-1578

DIMENSIONS and SPECIFICATIONS

ALL DIMENSIONS ARE TYPICAL TOL ± .500"

All Units Shipped Unassembled (KD) for Reduced Shipping Costs.

MS & MG Series UNDERSHELF Style FLAT TOP

Finished size of undershelf = Length minus 5 3/4"
Width minus 5 3/4"

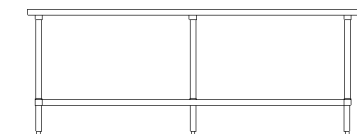

Units 8 ft. and larger are furnished with six (6) legs

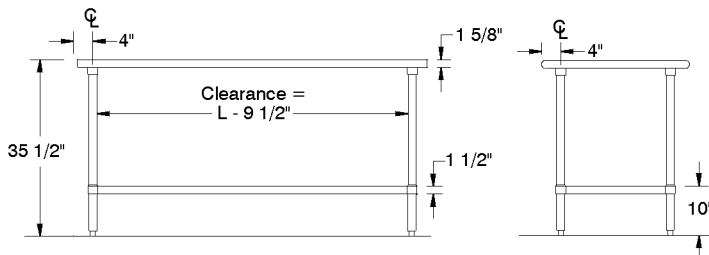
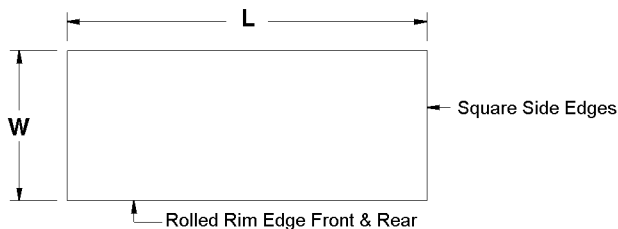

MS-Series: Stainless Steel Legs & Undershelf

MG-Series: Galvanized Steel Legs & Undershelf

L	24" Wide	Wt.	30" Wide	Wt.	36" Wide	Wt.
30"	MS-240	49 lbs.	MS-300	65 lbs.		
24"	MS-242	31 lbs.	MS-302	55 lbs.		
36"	MS-243	64 lbs.	MS-303	72 lbs.	MS-363	88 lbs.
48"	MS-244	79 lbs.	MS-304	89 lbs.	MS-364	98 lbs.
60"	MS-245	92 lbs.	MS-305	107 lbs.	MS-365	118 lbs.
72"	MS-246	109 lbs.	MS-306	125 lbs.	MS-366	138 lbs.
84"	MS-247	130 lbs.	MS-307	148 lbs.	MS-367	164 lbs.
96"	MS-248	145 lbs.	MS-308	166 lbs.	MS-368	184 lbs.
108"	MS-249	161 lbs.	MS-309	176 lbs.	MS-369	190 lbs.
120"	MS-2410	261 lbs.	MS-3010	287 lbs.	MS-3610	308 lbs.
132"	MS-2411	293 lbs.	MS-3011	324 lbs.	MS-3611	358 lbs.
144"	MS-2412	308 lbs.	MS-3012	339 lbs.	MS-3612	373 lbs.

L	24" Wide	Wt.	30" Wide	Wt.	36" Wide	Wt.
30"	MG-240	49 lbs.	MG-300	65 lbs.		
24"	MG-242	31 lbs.	MG-302	55 lbs.		
36"	MG-243	64 lbs.	MG-303	72 lbs.	MG-363	88 lbs.
48"	MG-244	79 lbs.	MG-304	89 lbs.	MG-364	98 lbs.
60"	MG-245	92 lbs.	MG-305	107 lbs.	MG-365	118 lbs.
72"	MG-246	109 lbs.	MG-306	125 lbs.	MG-366	138 lbs.
84"	MG-247	130 lbs.	MG-307	148 lbs.	MG-367	164 lbs.
96"	MG-248	145 lbs.	MG-308	166 lbs.	MG-368	184 lbs.
108"	MG-249	161 lbs.	MG-309	176 lbs.	MG-369	190 lbs.
120"	MG-2410	261 lbs.	MG-3010	287 lbs.	MG-3610	308 lbs.
132"	MG-2411	293 lbs.	MG-3011	324 lbs.	MG-3611	358 lbs.
144"	MG-2412	308 lbs.	MG-3012	339 lbs.	MG-3612	373 lbs.



ADVANCE TABCO is constantly engaged in a program of improving our products. Therefore, we reserve the right to change specifications without prior notice.



TRUE FOOD SERVICE EQUIPMENT, INC. • 2001 East Terra Lane • O'Fallon, Missouri 63366-4434
 ph. 636.240.2400 • toll free 800.325.6152 • fax 636.272.2408 • parts fax 636.272.9471 • www.truemfg.com

PROJECT NAME		LOCATION		AIA #
ITEM #	QTY	MODEL #		SIS #

SPEC SERIES®

ROLL-IN SOLID SWING DOOR REFRIGERATOR

models	STR2RRI-2S	STA2RRI-2S	STG2RRI-2S
--------	------------	------------	------------



STR2RRI-2S	
Exterior	Stainless steel door, front & sides.
Interior	Stainless steel side walls, back, floor, door liner, & ceiling.

STA2RRI-2S	
Exterior	Stainless steel door, front & sides.
Interior	Aluminum side walls & back. Stainless steel floor & ceiling.

STG2RRI-2S	
Exterior	Stainless steel door, with matching aluminum sides.
Interior	Aluminum side walls & back. Stainless steel floor & ceiling.

plan view

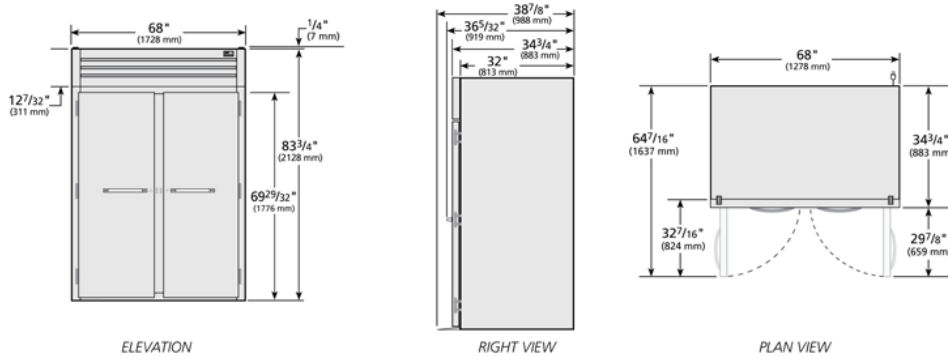

SPECIFICATIONS		
Dimensions	in.	mm.
Length	68	1728
Depth	34 3/4	883
Height	83 3/4	2128
Electrical	U.S.	International
Horsepower	1/2	N/A
Amps	11.8	N/A
Voltage	115/60/1	
NEMA	5-15P	
Cord Length	9 ft.	2.74 M.
115/60/1 NEMA-5-15R † Depth does not include 4 1/4" (108 mm) for ramp. * Height does not include 1" (26 mm) for system mechanical components.		

Specifications subject to change without notice.
 Chart dimensions are rounded up to the nearest 1/8" (millimeters rounded up to the next whole number).

	APPROVALS	AVAILABLE AT
8/14	Printed in U.S.A.	



TRUE FOOD SERVICE EQUIPMENT, INC. • 2001 East Terra Lane • O'Fallon, Missouri 63366-4434
ph. 636.240.2400 • toll free 800.325.6152 • fax 636.272.2408 • parts fax 636.272.9471 • www.truemfg.com

PROJECT NAME	LOCATION	AIA #
ITEM #	QTY	MODEL #
		SIS #

SPEC SERIES®

ROLL-IN SOLID SWING DOOR REFRIGERATOR

models

STR2RRI-2S

STA2RRI-2S

STG2RRI-2S



standard features

REFRIGERATION SYSTEM

- Factory engineered, self-contained, capillary tube system using environmentally friendly (CFC free) 134A refrigerant.
- Extra large evaporator coil balanced with higher horsepower compressor and large condenser maintains cabinet temperatures of 33°F to 38°F (.5°C to 3.3°C) for the best in food preservation.
- Sealed, cast iron, self-lubricating evaporator fan motor(s) and larger fan blades give True roll-in's a more efficient low velocity, high volume airflow design. This unique design ensures faster temperature recovery and shorter run times in the busiest of foodservice environments.
- Top mounted refrigeration system with evaporator positioned out of food zone to maximize capacity.

CABINET CONSTRUCTION

- Insulation - entire cabinet structure and solid door are foamed-in-place using Ecomate. A high density, polyurethane insulation that has zero ozone depletion potential (ODP) and zero global warming potential (GWP).
- Designed to accept roll-in racks (inboard castors) with maximum dimensions of 27"L x 29"D x 66"H (686 mm x 737 mm x 1677 mm)(supplied by others).
- One (1) heavy gauge stainless steel ramp.

DOORS

- Lifetime guaranteed bolt style door locks standard.
- Lifetime guaranteed heavy duty all metal working door handle.
- Positive seal self-closing door with 120° stay open feature. Lifetime guaranteed external cam lift door hinges, Three (3) per door section.
- Magnetic door gasket of one piece construction, removable without tools for ease of cleaning.

LIGHTING

- Incandescent interior lighting, safety shielded.

MODEL FEATURES

- Exterior digital temperature display, available with either °F or °C .
- Evaporator epoxy coated to eliminate the potential of corrosion
- Interior bumpers protect cabinet walls from abuse caused by roll-in carts.
- NSF-7 compliant for open food product.

ELECTRICAL

- Unit completely pre-wired at factory and ready for final connection to a 115/60/1 phase, 15 amp dedicated outlet. Cord and plug set included.

OPTIONAL FEATURES/ ACCESSORIES

(upcharge & lead times may apply)

- Stainless back. (STR, STA, STG)
- Field reversible hinge

WARRANTY*

Three year warranty on all parts and labor and an additional 2 year warranty on compressor. (U.S.A. only)

*RESIDENTIAL APPLICATIONS: TRUE assumes no liability for parts or labor coverage for component failure or other damages resulting from installation in non-commercial or residential applications.

METRIC DIMENSIONS ROUNDED UP TO THE NEAREST WHOLE MILLIMETER

SPECIFICATIONS SUBJECT TO CHANGE WITHOUT NOTICE



Model	Elevation	Right	Plan	3D	Back
ST()2RRI-2S					



Item No. _____

Quantity _____

Job Name _____

Spec No. _____

BUN PAN RACKS
ECONOMY ALL WELDED SET-UP
ALUMINUM CONSTRUCTION

Custom Sizes Available

Model	Spacing Capacity	H	W	D	Weight
400AC	FL 2"/30 Pans	70 ¹ / ₄ "	20 ¹ / ₂ "	26"	40
401AC	FL 3"/20 Pans	70 ¹ / ₄ "	20 ¹ / ₂ "	26"	34
405AC	FL 2"/27 Pans	64"	20 ¹ / ₂ "	26"	37
406AC	FL 3"/18 Pans	64"	20 ¹ / ₂ "	26"	32
410AC	SL 2"/30 Pans	70 ¹ / ₄ "	28 ¹ / ₂ "	18"	38
411AC	SL 3"/20 Pans	70 ¹ / ₄ "	28 ¹ / ₂ "	18"	30
415AC	SL 2"/27 Pans	64"	28 ¹ / ₂ "	18"	35
416AC	SL 3"/18 Pans	64"	28 ¹ / ₂ "	18"	30

Options:

- /011 Caster Brakes (2)
- /CC Card Clip, Aluminum
- /009 Pan Stop, Aluminum



Notes

55 Channel Drive • Port Washington, NY 11050-2216
8891 NW 102nd Street • Medley, FL 33178
Tel: 516-944-6271 • Fax: 516-944-0625
Toll Free: 866-712-7283
www.channelmfg.com • Email: sales@channelmfg.com

TRUE FOOD SERVICE EQUIPMENT, INC. 2001 East Terra Lane • O'Fallon, Missouri 63366-4434 • (636)240-2400 Fax (636)272-2408 • Toll Free (800)325-6152 • Intl Fax# (001)636-272-7546 Parts Dept. (800)424-TRUE • Parts Dept. Fax# (636)272-9471 • www.truemfg.com	Project Name: _____ Location: _____ Item #: _____ Qty: _____ Model #: _____	A/A # S/S #
	Model: T-49	T-Series: Reach-In Solid Swing Door Refrigerator



Scan code for video

T-49

- ▶ True's solid door reach-in's are designed with enduring quality that protects your long term investment.
- ▶ Designed using the highest quality materials and components to provide the user with colder product temperatures, lower utility costs, exceptional food safety and the best value in today's food service marketplace.
- ▶ Oversized, factory balanced, refrigeration system holds 33°F to 38°F (.5°C to 3.3°C) for the best in food preservation.
- ▶ Stainless steel solid doors and front. The finest stainless available with higher tensile strength for fewer dents and scratches.
- ▶ Adjustable, heavy duty PVC coated shelves.
- ▶ Positive seal self-closing doors. Lifetime guaranteed door hinges and torsion type closure system.

Bottom mounted units feature:

- ▶ "No stoop" lower shelf.
- ▶ Storage on top of cabinet.
- ▶ Compressor performs in coolest, most grease free area of kitchen.
- ▶ Easily accessible condenser coil for cleaning.

ROUGH-IN DATA

Specifications subject to change without notice. Chart dimensions rounded up to the nearest 1/8" (millimeters rounded up to next whole number).

Model	Doors	Shelves	Cabinet Dimensions (inches) (mm)			HP	Voltage	Amps	NEMA Config.	Cord Length (total ft.) (total m)	Crated Weight (lbs.) (kg)
			L	D	H*						
T-49	2	6	54 1/8	29 1/2	78 3/8	1/3	115/60/1	5.8	5-15P	9	425
			1375	750	1991	1/2	230-240/50/1	5.4	▲	2.74	193

* Height does not include 5" (127 mm) for castors or 6" (153 mm) for optional legs. ▲ Plug type varies by country.

	APPROVALS:	AVAILABLE AT:
2/15 Printed in U.S.A.		

Model:
T-49

T-Series:
Reach-In Solid Swing Door Refrigerator

TRUE®

STANDARD FEATURES

DESIGN

- True's commitment to using the highest quality materials and over sized refrigeration systems provides the user with colder product temperatures, lower utility costs, exceptional food safety and the best value in today's food service marketplace.

REFRIGERATION SYSTEM

- Factory engineered, self-contained, capillary tube system using environmentally friendly (CFC free) 134A refrigerant.
- Extra large evaporator coil balanced with higher horsepower compressor and large condenser; maintains 33°F to 38°F (5°C to 3.3°C) for the best in food preservation.
- Sealed, cast iron, self-lubricating evaporator fan motor(s) and larger fan blades give True reach-in's a more efficient low velocity, high volume airflow design. This unique design ensures faster temperature recovery and shorter run times in the busiest of food service environments.
- Bottom mounted condensing unit positioned for easy maintenance. Compressor runs in coolest and most grease free area of the kitchen. Allows for storage area on top of unit.

CABINET CONSTRUCTION

- Exterior - Stainless steel front. Anodized quality aluminum ends, back and top.
- Interior - attractive, NSF approved, clear coated aluminum liner. Stainless steel floor with coved corners.

- Insulation - entire cabinet structure and solid doors are foamed-in-place using Ecomate. A high density, polyurethane insulation that has zero ozone depletion potential (ODP) and zero global warming potential (GWP).
- Welded, heavy duty steel frame rail, black powder coated for corrosion protection.
- Frame rail fitted with 4" (102 mm) diameter stem castors - locks provided on front set.

DOORS

- Stainless steel exterior with white aluminum liners to match cabinet interior. Doors extend full width of cabinet shell. Door locks standard.
- Lifetime guaranteed recessed door handles. Each door fitted with 12" (305 mm) long recessed handle that is foamed-in-place with a sheet metal interlock to ensure permanent attachment.
- Positive seal self-closing doors. Lifetime guaranteed door hinges and torsion type closure system.
- Magnetic door gaskets of one piece construction, removable without tools for ease of cleaning.

SHELVING

- Six (6) adjustable, heavy duty PVC coated wire shelves 24⁵/₁₆"L x 22³/₈"D (624 mm x 569 mm). Four (4) chrome plated shelf clips included per shelf.
- Shelf support pilasters made of same material as cabinet interior; shelves are adjustable on 1/2" (13 mm) increments.

LIGHTING

- Incandescent interior lighting - safety shielded. Lights activated by rocker switch mounted above doors.

MODEL FEATURES

- Exterior temperature display.
- Evaporator is epoxy coated to eliminate the potential of corrosion.
- NSF-7 compliant for open food product.

ELECTRICAL

- Unit completely pre-wired at factory and ready for final connection to a 115/60/1 phase, 15 amp dedicated outlet. Cord and plug set included.



115/60/1
NEMA-5-15R

OPTIONAL FEATURES/ACCESSORIES

Upcharge and lead times may apply.

- 230 - 240V / 50 Hz.
- 6" (153 mm) standard legs.
- 6" (153 mm) seismic/flanged legs.
- Alternate door hinging (factory installed).
- Additional shelves.
- Half door bun tray racks. Each holds up to eleven 18"L x 26"D (458 mm x 661 mm) sheet pans (sold separately).
- Full door bun tray racks. Each holds up to twenty-two 18"L x 26"D (458 mm x 661 mm) sheet pans (sold separately).

*CABINET INTERIOR

Beginning in October of 2014, True Manufacturing began the process of changing the standard interior finishes on select products. The interior liners of these units have changed from the traditional NSF-approved white aluminum to an NSF-approved clear coated aluminum that is silver in color. In addition, the traditional white PVC coated shelves have been switched to a gray PVC coating. There are no functional differences created by any of these changes, the difference is only in the appearance. The following product lines are affected by this change: T-Series, TUC, TWT, TSSU, TFP, TPP, TMC, TRCB. A sticker will be placed on the outside packaging so that units with this change can be identified in inventory.

PLAN VIEW

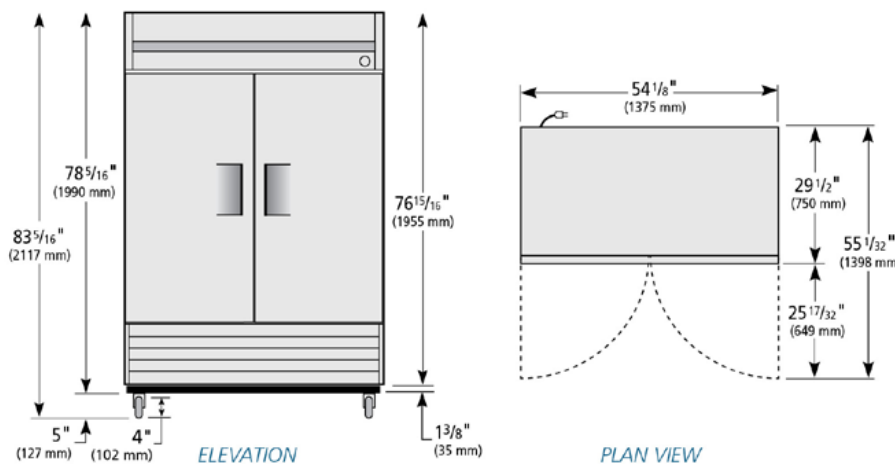

WARRANTY*

Three year warranty on all parts and labor and an additional 2 year warranty on compressor. (U.S.A. only)

METRIC DIMENSIONS ROUNDED UP TO THE NEAREST WHOLE MILLIMETER

SPECIFICATIONS SUBJECT TO CHANGE WITHOUT NOTICE



Model	Elevation	Right	Plan	3D	Back
T-49	TFGY36E	TFEY03S	TFEY02P	TFGY363	

*RESIDENTIAL APPLICATIONS: TRUE assumes no liability for parts or labor coverage for component failure or other damages resulting from installation in non-commercial or residential applications.

TRUE FOOD SERVICE EQUIPMENT

2001 East Terra Lane • O'Fallon, Missouri 63366-4434 • (636)240-2400 • Fax (636)272-2408 • Toll Free (800)325-6152 • Intl. Fax# (001)636-272-7546 • www.truefmfg.com

OLYMPIC
STORAGE COMPANY

Reliable space ... economically.



NSF®

OLYMPIC WIRE SHELVING GREEN EPOXY

- **Unique Design:** The open wire design of these carbon-steel shelves minimizes dust accumulation and allows a free circulation of air, greater visibility of stored items and greater light penetration.
- **Versatile Construction:** Olympic wire shelving can change as quickly as your needs change.
- **Fast, Secure Assembly:** Posts have circular grooves at 1" (25mm) intervals. A tapered split sleeve snaps together around each post. Tapered openings in the shelf corners slide over the tapered split sleeves providing a positive lock. Shelf is assembled in minutes without the use of any special tools.
- **Shelf Wires:** Run front to back, allowing you to slide items on and off shelves smoothly.
- **Shelf Accessibility:** Shelves can be loaded/unloaded easily from all sides. This open construction allows use of maximum storage space of cube.
- **Adjustability:** Shelves can be adjusted at 1" (25mm) intervals along the entire length of the post.
- **Finish:** Green epoxy finish with chromate substrate.
- **Posts:** Bolt levelers compensate for surface irregularities on stationary posts. Posts also available for mobile application.
- **Warranty:** Olympic green epoxy coated shelves and posts carry a 7 year limited warranty against rust and corrosion.

OLYMPIC
STORAGE COMPANY
Reliable space ... economically.

Wire Shelving Green Epoxy

OLYMPIC
STORAGE COMPANY
Reliable space ... economically.

Olympic Storage Company

OLYMPIC WIRE SHELVING GREEN EPOXY

OLYMPIC™
STORAGE COMPANY

Reliable space ... economically.

WIRE SHELVES

Width/Length		Approx. Weight Per Shelf		Pack Quantity	Green Epoxy
(in.)	(mm)	(lbs.)	(kg)		
14 x 30	355 x 760	7	3.2	4	J1430K
14 x 36	355 x 914	8	3.6	4	J1436K
14 x 42	355 x 1066	9.5	4.3	4	J1442K
14 x 48	355 x 1219	10.5	4.7	4	J1448K
14 x 60	355 x 1524	14	6.3	2	J1460K
14 x 72	355 x 1829	17	7.7	2	J1472K
18 x 24	457 x 610	7	3.2	4	J1824K
18 x 30	457 x 760	8	3.6	4	J1830K
18 x 36	457 x 914	9.5	4.3	4	J1836K
18 x 42	457 x 1066	11	5	4	J1842K
18 x 48	457 x 1219	12	5.4	4	J1848K
18 x 54	457 x 1370	14.5	6.6	2	J1854K
18 x 60	457 x 1524	17	7.7	2	J1860K
18 x 72	457 x 1829	20	9.1	2	J1872K
21 x 24	530 x 610	8	3.6	4	J2124K
21 x 30	530 x 760	9	4.1	4	J2130K
21 x 36	530 x 914	11	5	4	J2136K
21 x 42	530 x 1066	12	5.4	4	J2142K
21 x 48	530 x 1219	14	6.4	4	J2148K
21 x 54	530 x 1370	16	7.3	2	J2154K
21 x 60	530 x 1524	18	8.2	2	J2160K
21 x 72	530 x 1829	24	10.9	2	J2172K
24 x 24	610 x 610	9	4.1	4	J2424K
24 x 30	610 x 760	11	5.0	4	J2430K
24 x 36	610 x 914	13	5.9	4	J2436K
24 x 42	610 x 1066	15	6.8	4	J2442K
24 x 48	610 x 1219	16	7.3	4	J2448K
24 x 54	610 x 1370	19	8.6	2	J2454K
24 x 60	610 x 1524	21	9.5	2	J2460K
24 x 72	610 x 1829	26	11.8	2	J2472K

Load Capacity:

Up to 48" (1220mm) Length = 800 lbs. (363kg), evenly distributed.

54" - 72" (1829mm) Length = 600 lbs. (272kg), evenly distributed.

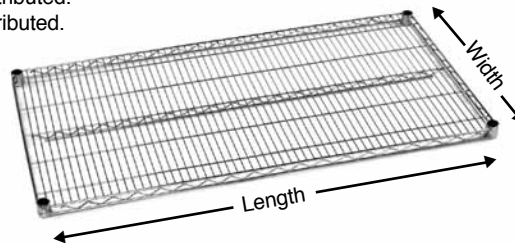

Split Sleeves

POSTS

Approx. Weight Per Post (lbs.)	Pack Quantity	Height*		Cat. No. Stationary Post Green Epoxy	Height**		Cat. No. Mobile Post Green Epoxy	
		Stationary Post (in.)	(mm)		Mobile Post (in.)	(mm)		
2	0.9	8	34 1/2	875	J33K	34 3/4	857	J33UK
3	1.4	8	54 9/16	1385	J54K	53 13/16	1366	J54UK
3 1/2	1.6	8	62 9/16	1590	J63K	61 13/16	1570	J63UK
4	1.8	8	75 5/8	1895	J74K	73 7/8	1873	J74UK
5	2.3	8	86 5/8	2200	J86K	85 7/8	2181	J86UK

*Height includes leveling bolt and cap.

**Mobile posts come without leveling bolt assembly and accommodate stem casters.

Height is for post only.

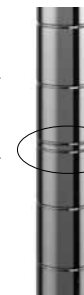

Posts are grooved at 1" (25mm) increments and numbered at 2" (50mm) increments. Posts are double-grooved every 8" (203mm) for easy identification.

Wire Shelving Green Epoxy

OLYMPIC™
STORAGE COMPANY
Reliable space ... economically.

OLYMPIC™
STORAGE COMPANY
Reliable space ... economically.

OLY-001E - Epoxy Wire Shelving
Rev. 3/10

Information and specifications are subject to change without notice. Please confirm at time of order.

Copyright © 2010 Olympic Storage Company

OLYMPIC STORAGE COMPANY

Reliable space . . . economically.

OLYMPIC
STORAGE COMPANY
Reliable space . . . economically.

Wire Shelving Accessories

WIRE SHELVING ACCESSORIES NSF

Direct Wall Mounts

Each consists of one shelf support and mounting plate. Use single support at shelf ends; double support for adjoining shelves. (Single — Two required per shelf.)



SINGLE



DOUBLE

Shelf Width		Approx. Pkd. Wt.		Model No.	Model No.	Approx. Pkd. Wt.		Model No.	Model No.
(in.)	(mm)	(lbs.)	(kg)	Chrome	Green Epoxy	(lbs.)	(kg)	Chrome	Green Epoxy
14	355	1.5	0.7	J1WD14C	J1WD14K	3	1.4	J2WD14C	J2WD14K
18	457	2	0.9	J1WD18C	J1WD18K	4	1.8	J2WD18C	J2WD18K
24	610	3	1.4	J1WD24C	J1WD24K	4.5	2.0	J2WD24C	J2WD24K

Stem Casters — Resilient Rubber (Order By Each)

Use with posts to create a mobile shelving unit to meet your special needs. Each caster is constructed of resilient rubber wheels and plated components. Load rating is 200 lbs. (90kg) per caster. Sold by the piece.

Wheel Diameter	Face	Load Rating		Type	Wheel Tread	Approx. Pkd. Wt.		Model No.
(in.)	(mm)	(lbs.)	(kg)			(lbs.)	(kg)	
5	127	1 1/4	32	Stem/Swivel	Resilient	2 1/2	1.1	J5
5	127	1 1/4	32	Stem/Brake	Resilient	2 5/8	1.2	J5B



Stem Caster Kit — High Modulus Rubber (One Kit = Four Casters)

Kit consists of four swivel casters with brakes. Each caster is constructed of durable, non-marking high modulus rubber. Load rating is 300 lbs. (136kg) per caster.

Wheel Diameter	Face	Load Rating		Type	Wheel Tread	Approx. Pkd. Wt.		Model No.
(in.)	(mm)	(lbs.)	(kg)			(lbs.)	(kg)	
5	127	1 1/4	32	Stem/Brake	Flat High Modulus Rubber	9	4.1	J5FBA-4



Stackable Shelf Ledges

4" (100mm) High.

Shelf Width		Approx. Pkd. Wt.		Model No.
(in.)	(mm)	(lbs.)	(kg)	Chrome
14	355	0.83	0.36	JL14-4C
18	457	1.5	0.68	JL18-4C
24	610	2	0.9	JL24-4C
30	760	2.25	1.03	JL30-4C
36	914	2.75	1.25	JL36-4C
48	1219	3.75	1.68	JL48-4C
60	1524	4	1.81	JL60-4C
72	1828	5	2.25	JL72-4C

NOTE: Actual ledge length is approximately 1" (25mm) shorter than nominal shelf length/width.



Shelf Dividers for Shelves

Keep shelf contents orderly with these 8" (203mm) high, pressure-fit dividers.

Shelf Width	Approx. Pkd. Wt.	Model No.
(in.)	(lbs.)	Chrome
18	2.25	JDD18C
24	2.75	JDD24C

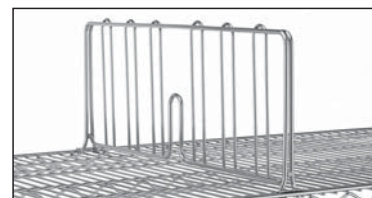

Replacement Plastic Split Sleeves

One bag required per shelf; 4 pairs per bag. Model No. J9985



"S" Hook

Two are required for each storage level. Model No. J9995Z



Foot Plate

Use to bolt units to the floor, or when a broader, more stable foot is desired. Zinc Finish. Model No. J9993Z



**OLYMPIC
STORAGE COMPANY**
Reliable space . . . economically.

Information and specifications are subject to change without notice. Please confirm at time of order.

Copyright © 2011 Olympic Storage Company

OLY-005E • Rev. 7/11