



Intelligent Heat Detectors with Optional CO Sensors

SIGA2-HFS, SIGA2-HRS, SIGA2-HCOS



Overview

Signature Series fixed temperature and rate-of-rise heat detectors bring advanced sensing technology to a practical design that increases efficiency, saves installation time, cuts costs, and extends property protection capabilities. Continuous self-diagnostics ensure reliability over the long-haul, while the latest thermister technology makes these detectors ideal wherever dependable heat detection is required. With their modular CO sensor, these devices pull double-duty — continually monitoring the environment for heat from combustion, as well as its invisible yet deadly companion, carbon monoxide.

Like all Signature Series detectors, these are intelligent devices that gather analog information from their heat and CO sensor (if present), converting this data into digital signals. To make an alarm decision, the detector's on-board microprocessor measures and analyzes sensor readings and compares this information to historical data. Digital filters remove signal patterns that are not typical of fires, thus virtually eliminating unwanted alarms.

The SIGA2-HCOS is a fixed temperature heat detector that includes an advanced carbon monoxide sensor and daughterboard. When the electrochemical cell reaches its end of life after approximately six years, the detector signals a trouble condition to the control panel. The sensor/daughterboard module is field-replaceable.

Standard Features

Note: Some features described here may not be supported by all control systems. Check your control panel's Installation and Operation Guide for details.

- Fixed temperature or rate-of-rise heat detection with optional carbon monoxide sensor
- Field-replaceable carbon monoxide sensor/daughterboard module
- Uses existing wiring
- Automatic device mapping
- Ground fault detection by module
- Up to 250 devices per loop
- Non-volatile memory
- Electronic addressing
- Bicolor (green/red) status LED
- Standard, relay, fault isolator, and audible mounting bases
- 50 foot (15.2 meter) spacing
- 15 °F (9 °C) per minute rate-of-rise alarm point (HRS)
- 135 °F (57 °C) fixed temperature alarm point (HFS/HRS/HCOS)

Application

Heat detection

SIGA2-HRS combination fixed temperature/rate-of-rise heat detectors provide a 15 °F (9 °C) per minute rate-of-rise heat sensor for the detection of fast-developing fires, as well as a 135°F (57°C) fixed temperature sensor for slow building-fires. The heat sensor monitors the temperature of the air and determines whether an alarm should be initiated.

SIGA2-HFS and SIGA2-HCOS fixed temperature heat detectors provide a 135°F (57°C) fixed-temperature heat sensor for the detection of heat due to fire. The heat sensor monitors the temperature of the air and determines whether an alarm should be initiated.

Carbon monoxide detection

The SIGA2-HCOS includes a replaceable chemical cell for the detection of carbon monoxide (CO). CO detection has rapidly become a standard part of life safety strategies everywhere. Monitored CO detection is becoming mandated with increasing frequency in all types of commercial applications, but particularly in occupancies such as hotels, rooming houses, dormitories, day care facilities, schools, hospitals, assisted living facilities, and nursing homes. In fact, more than half of the U.S. population already lives in states requiring the installation of CO detectors in some commercial occupancies. This is because carbon monoxide is the leading cause of accidental poisoning deaths in America. Known as the “Silent Killer,” CO is odorless, tasteless, and colorless. It claims nearly 500 lives, and results in more than 15,000 hospital visits annually.

Installation

Signature Series detectors mount to North American 1-gang boxes, 3-1/2 inch or 4 inch octagon boxes, and to 4 inch square electrical boxes 1-1/2 inches (38 mm) deep. They mount to European BESA and 1-gang boxes with 60.3 mm fixing centers. See mounting base installation and wiring for more information.

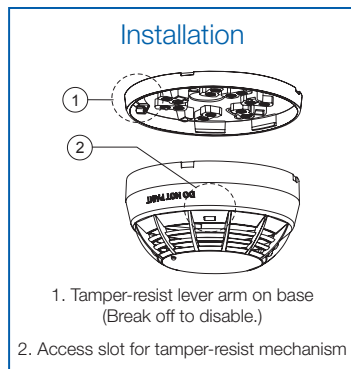

Testing & Maintenance

The user-friendly maintenance program shows the current state of each detector and other pertinent messages. Single detectors may be turned off temporarily from the control panel. Availability of maintenance features is dependent on the fire alarm system used. When the CO sensor's electrochemical cell reaches its end of life, the detector signals a trouble condition to the control panel. The sensor/daughterboard module is field-replaceable. Scheduled maintenance (Regular or Selected) for proper detector operation should be planned to meet the requirements of the Authority Having Jurisdiction (AHJ). Refer to current NFPA 72, NFPA 720, and ULC CAN/ULC 536 standards.

Compatibility

SIGA2 series detectors are compatible only with the Signature Loop Controller.

Sensing and reporting technology

The microprocessor in each detector provides four additional benefits - Self-diagnostics and History Log, Automatic Device Mapping, Stand-alone Operation and Fast, Stable Communication.

Self-diagnostics and History Log - Each Signature Series detector constantly runs self-checks to provide important maintenance information. The results of the self-check are automatically updated and permanently stored in the detector's non-volatile memory

Automatic Device Mapping - The loop controller learns where each device's serial number address is installed relative to other devices on the circuit. The mapping feature provides supervision of each device's installed location to prevent a detector from being reinstalled (after cleaning etc.) in a different location from where it was originally.

Stand-alone Operation - A decentralized alarm decision by the detector is guaranteed. On-board intelligence permits the detector to operate in stand-alone mode. If loop controller CPU communications fail for more than four seconds, all devices on that circuit go into stand-alone mode. The circuit acts like a conventional alarm receiving circuit.

Fast Stable Communication - On-board intelligence means less information needs to be sent between the detector and the loop controller. Other than regular supervisory polling response, the detector only needs to communicate with the loop controller when it has something new to report.

Accessories

Detector mounting bases have wiring terminals that are accessible from the “room-side” after mounting the base to the electrical box. The bases mount to North American 1-gang boxes and to 3½ inch or 4 inch octagon boxes, 1½ inches (38 mm) deep. They also mount to European BESA and 1-gang boxes with 60.3 mm fixing centers. The SIGA-SB4, SIGA-RB4, and SIGA-IB4 mount to North American 4 inch sq. electrical boxes in addition to the above boxes. They include the SIGA-TS4 Trim Skirt which is used to cover the “mounting ears” on the base. The SIGA-AB4G mounts to a 4” square box only.

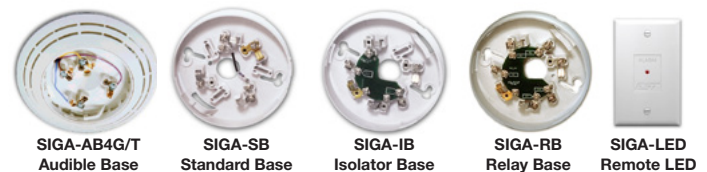

Remote LED SIGA-LED - The remote LED connects to the SIGA-SB or SIGA-SB4 Standard Base only. It features a North American size 1-gang plastic faceplate with a white finish and red alarm LED.

SIGA-TS4 Trim Skirt - Supplied with 4 inch bases, it can also be ordered separately to use with the other bases to help hide surface imperfections not covered by the smaller bases.

SIGA-AB4G and SIGA-AB4GT - These sounder bases are designed for use where localized or group alarm signaling is required. The SIGA-AB4G is compatible with Signature Series smoke and heat detectors. The SIGA-AB4GT sounder base, when used with the SIGA-TCDR Temporal Pattern Generator module, adds an audible output function to any Signature Series detector, including fire and CO detectors.

Typical Wiring

The detector mounting bases accept #18 AWG (0.75mm²), #16 (1.0mm²), #14 AWG (1.5mm²), and #12 AWG (2.5mm²) wire sizes.

Note: Sizes #16 AWG (1.0mm²) and #18 AWG (0.75mm²) are preferred for ease of installation. See Signature Loop Controller catalog sheet for detailed wiring requirement specifications.

Standard Detector Base, SIGA-SB, SIGA-SB4

This is the basic mounting base for Edwards Signature Series detectors. The SIGA-LED Remote LED is supported by the Standard Base.

Term	Description
1	Not Used
2	DATA IN/OUT (+)
3	Not Used
4	DATA IN (-)
5	Remote LED (+)
6	Remote LED (-)
7	Not Used
8	DATA OUT (-)

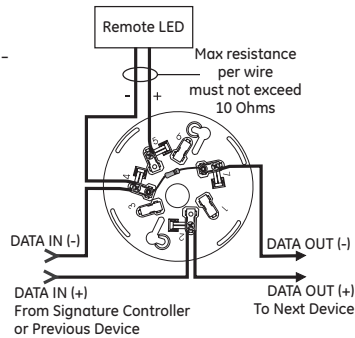

Isolator Detector Base, SIGA-IB, SIGA-IB4

This base includes a built-in line fault isolator for use on Class A circuits. A detector must be installed for it to operate. The isolator base does not support the SIGA-LED Remote LED.

The isolator operates as follows:

- a short on the line causes all isolators to open within 23 msec
- at 10 msec intervals, beginning on one side of the Class A circuit nearest the loop controller, the isolators close to provide the next isolator down the line with power
- when the isolator next to the short closes, reopens within 10 msec.

The process repeats beginning on the other side of the loop controller.

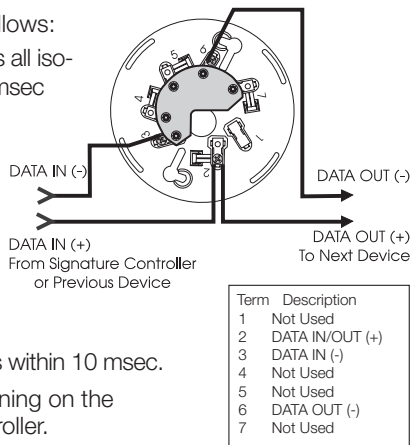

Relay Detector Base, SIGA-RB, SIGA-RB4

This base includes a relay. Normally open or closed operation is selected during installation.

The dry contact is rated for 1 amp (pilot duty) @ 30 Vdc. The relay's position is supervised to avoid accidentally jarring it out of position. The SIGA-RB can be operated as a control relay if programmed to do so at the control panel (EST3 V.2 only). The relay base does not support the SIGA-LED Remote LED.

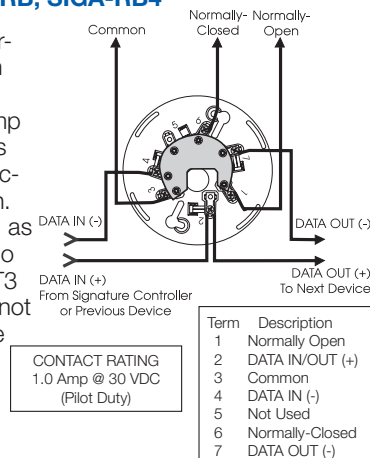

Audible Detector Base for CO and Fire Detectors, SIGA-AB4GT

The Signature Series AB4GT sounder base, when used with the SIGA-TCDR Temporal Pattern Generator, adds an audible output function to any Signature Series detector. For more information on this device, refer to *Data Sheet 85001-0623 -- Sounder Base for CO and Fire Detectors*.

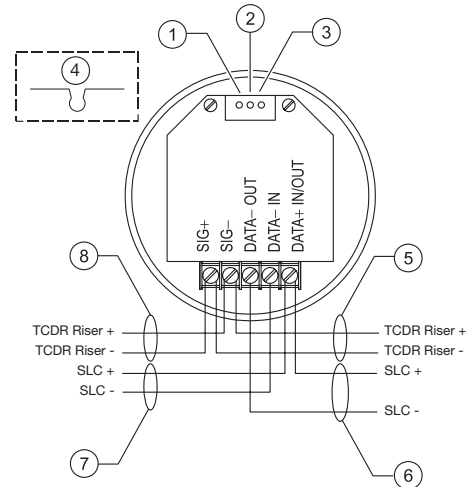

1. Volume setting. Default is high volume. For low volume, cut trace per item 4.
2. Reserved for future use. Do not cut.
3. Reserved for future use. Do not cut.
4. To configure output volume, cut trace as shown.
5. To next SIGA-AB4GT sounder base or EOL relay.
6. SLC_OUT to next intelligent addressable device.
7. SLC_IN from intelligent addressable controller or previous device.
8. From SIGA-TCDR Temporal Pattern Generator or previous SIGA-AB4GT sounder base.

Audible Detector Base, SIGA-AB4G

This base is designed for use where localized or group alarm signaling is required. When the detector senses an alarm condition, the audible base emits a local alarm signal. The optional SIGA-CRR Polarity Reversal Relay can be used for sounding to other audible bases on the same 24 Vdc circuit.

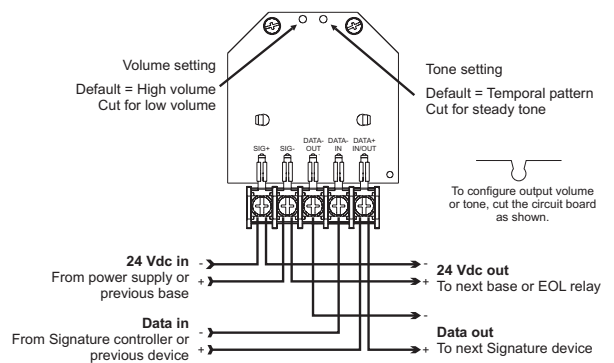

Relay and Audible Bases operate as follows:

- at system power-up or reset, the relay is de-energized
- when a detector is installed in the base with the power on, the relay energizes for four seconds, then de-energizes
- when a detector is removed from a base with the power on, the relay is de-energized
- when the detector enters the alarm state, the relay is energized.



Contact us...

Email: edwards.fire@fs.utc.com
 Web: www.est-fire.com

EST is an **EDWARDS** brand.
 1016 Corporate Park Drive
 Mebane, NC 27302

In Canada, contact Chubb Edwards...
 Email: inquiries@chubbedwards.com
 Web: www.chubbedwards.com

© 2013 UTC Fire & Security Americas Corporation, Inc. All rights reserved. Specifications subject to change without notice. Edwards is part of UTC Climate, Controls & Security, a unit of United Technologies Corporation.

Warnings & Cautions

- This detector does not operate without electrical power. As fires frequently cause power interruption, discuss further safeguards with the local fire protection specialist.
- This detector does not sense fires in areas where heat cannot reach the detector. Heat from fires in walls, roofs, or on the opposite side of closed doors may not reach the detector.
- This heat detector by itself does not provide life safety protection Use this detector with ionization and/or photoelectric smoke detectors.
- This detector does not detect oxygen levels, smoke, toxic gases, or flames. Use this device as part of a broad-based life safety program which includes a variety of information sources pertaining to heat and smoke levels, extinguishment systems, visual and audible devices, and other safety measures.
- Independent studies indicate that heat detectors should only be used when property protection alone is involved. Never rely on heat detectors as the sole means of fire protection.

Specifications

	SIGA2-HRS	SIGA2-HFS	SIGA2-HCOS
Normal operating current	45 µA	45 µA	45 µA
Standalone alarm current	18 mA	18 mA	18 mA
Alarm Current	45 µA	45 µA	45 µA
Rate-of-rise alarm point	15°F (9°C)/min.	N/A	N/A
Fixed temperature alarm point	130 to 140°F (54 to 60°C)		
Operating voltage	15.20 to 19.95 VDC		
Maximum spacing	50 ft. (15.2 m) centers*		
Construction	High impact engineering polymer		
Mounting	Plug-in		
Shipping weight	0.44 lb. (164 g)		
Compatible bases	See Ordering Information		
Operating environment	32 °F to 100 °F (0 °C to 38 °C), 0 to 93% RH, noncondensing		
Storage temperature	– 4 °F to 140 °F (– 20 °C to 60 °C)		

*When replacing SIGA-HRS/HFS ensure spacing is 50ft or less.

Ordering Information

Catalog Number	Description	Ship Wt. lbs (kg)
SIGA2-HRS	Intelligent combination fixed temperature/rate-of-rise heat detector	0.4 (0.16)
SIGA2-HFS	Intelligent fixed temperature heat detector	0.4 (0.16)
SIGA2-HCOS	Intelligent fixed temperature heat detector with CO sensor	0.4 (0.16)
SIGA2-HCOS-CA	Intelligent fixed temperature heat detector with CO sensor (for use in Canadian markets only)	0.4 (0.16)

Accessories		
SIGA-SB	Detector Mounting Base - Standard	
SIGA-SB4	4-inch Detector Mounting Base c/w Trim Skirt	
SIGA-RB	Detector Mounting Base w/Relay	
SIGA-RB4	4-inch Detector Mounting Base w/Relay, c/w Trim Skirt	0.2 (.09)
SIGA-IB	Detector Mounting Base w/Fault Isolator	
SIGA-IB4	4-inch Detector Mounting Base w/ Fault Isolator, c/w Trim Skirt	
SIGA-LED	Remote Alarm LED (not for EN54 applications)	
SIGA-AB4G	Audible (Sounder) Base for Fire Detectors	0.3 (0.15)
SIGA-AB4GT	Audible (Sounder) Base for CO and Fire Detectors	0.3 (0.15)
SIGA-TCDR	Temporal Pattern Generator	0.3 (0.15)
SIGA-TS4	Trim Skirt (supplied with 4-inch bases)	0.1 (.04)
2-CORPL	Replacement CO Sensor	0.1 (.04)