

**NO
EXCUSES!**

Click Here to Return to
Bill of Material/Index



Battery Cabinet Accessory



The BCA Battery Cabinet Accessory is designed for the professional installation of systems requiring battery storage and meets the requirement of NFPA 72 (1-5.2.9) standby battery storage for battery backup. The BCA allows for easy access and maintenance of the batteries while also assisting against unnecessary power drain, interference or degeneration of the battery. The unit can be mounted securely to a wall, preventing mechanical injury or damage to other equipment.



Constructed from heavy duty 16 gauge steel with a full length piano hinged door to allow optimum access to your equipment within the cabinet. Other features include a high security CAT 30 keyed door lock and vented sides. Complete interior and exterior finish is accomplished by a phosphate treatment followed by a durable baked-on textured polyester coating.

RED SAE P/N: SSU00500
BLACK SAE P/N: SSU00501

Standard Features:

- 16 Gauge (.062 thk.) cold rolled steel
- Stainless steel piano hinge
- Red or black textured finish
- CAT 30 keyed door lock
- Dimensions:
 - 22" wide x 10" high x 8 1/2" deep
- Four 1/2" and 3/4" EMT conduit knockouts located on both sides and back
- Wall mounting holes

Integration Accessories

Space Age Electronics, Inc.
406 Lincoln Street
Marlboro, MA 01752-2195
www.1sae.com
800.486.1723—voice
508.485.0966
508.485.4740—fax



ADA



ISO9001
REGISTERED



Made In U.S.A.

Description:

The **BCA Battery Cabinet Accessory** is constructed of 16 gauge (.062 thk.) cold rolled steel and finished with a complete interior and exterior durable red or black textured, heat-resistant baked-on enamel finish. The front cover features a full length stainless steel piano hinge and includes a high security CAT 30 keyed door lock. Overall dimensions measure 22" wide by 10" high by 8 1/2" deep. Four 1/2" and 3/4" EMT conduit knockouts are located on the sides and back. The battery cabinet meets NFPA 72 (1-5.2.9) and the National Electric Code requirements. Batteries not included.

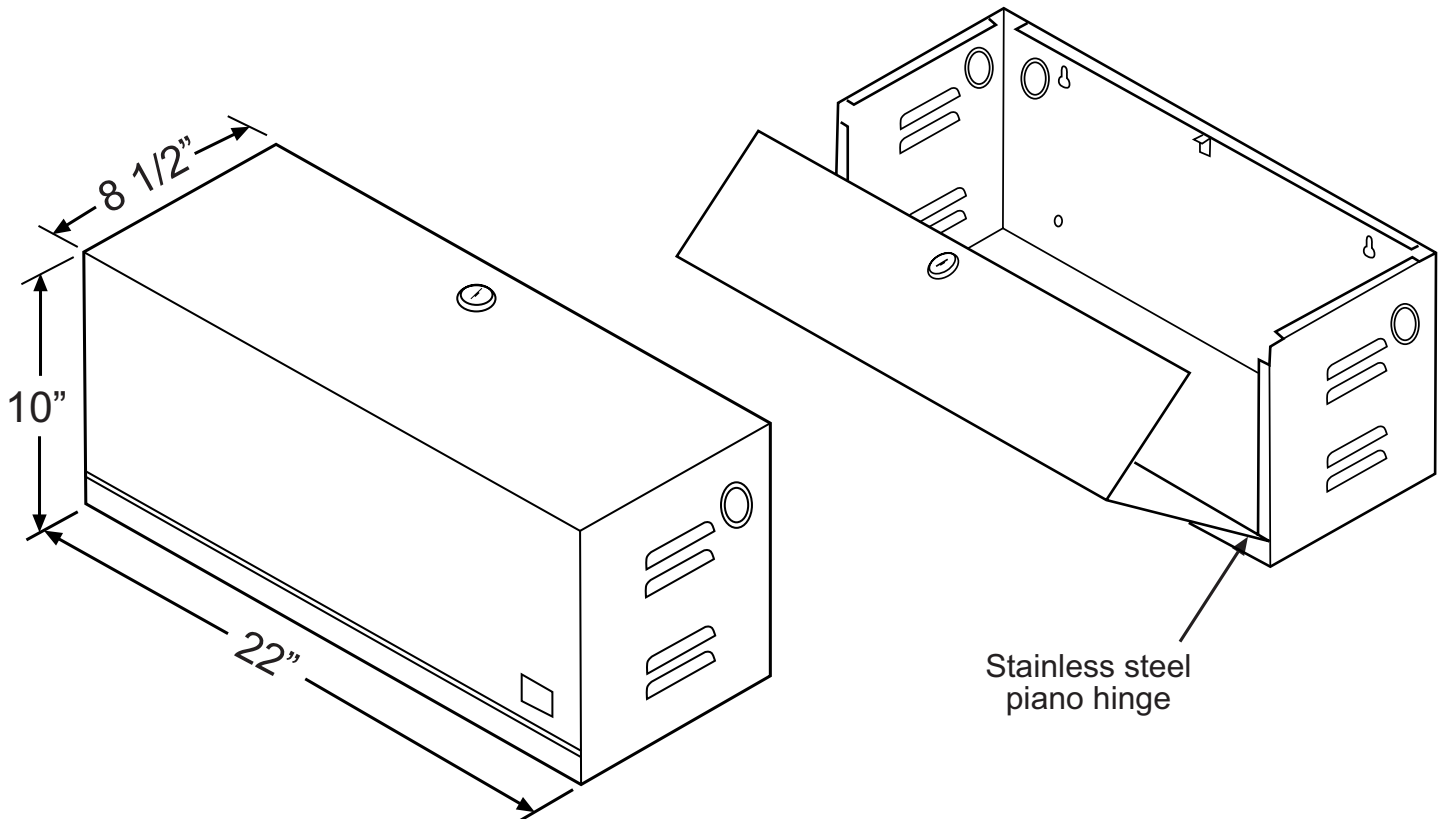

Ordering Information:

Part #	Description
SSU00500	BCA Battery Cabinet Accessory - Red
SSU00501	BCA Battery Cabinet Accessory - Black

Integration Accessories

Space Age Electronics, Inc.
 406 Lincoln Street
 Marlboro, MA 01752-2195
www.1sae.com
800.486.1723—voice
 508.485.0966
 508.485.4740—fax