

TYP SLAB DETAIL
N.T.S.

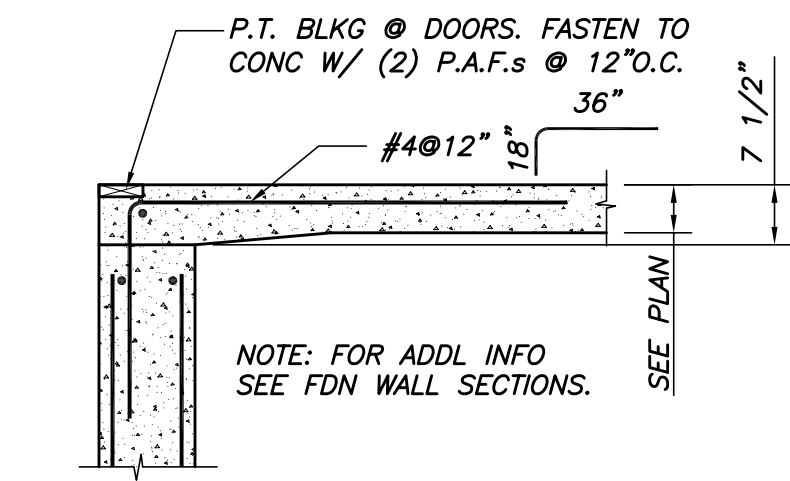

TYP SLAB DETAIL @ DOOR
N.T.S.

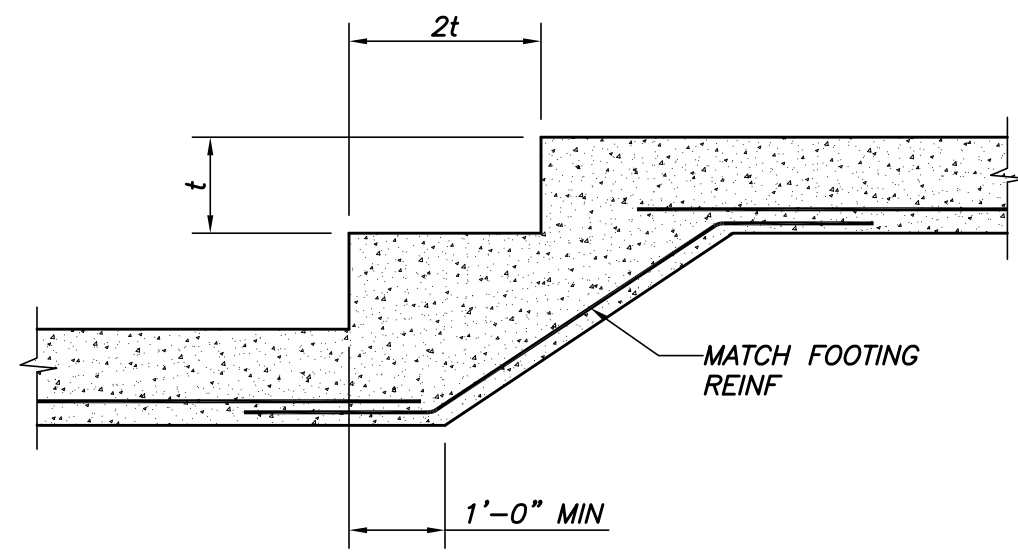

TYP STEP FOOTING DETAIL
N.T.S.

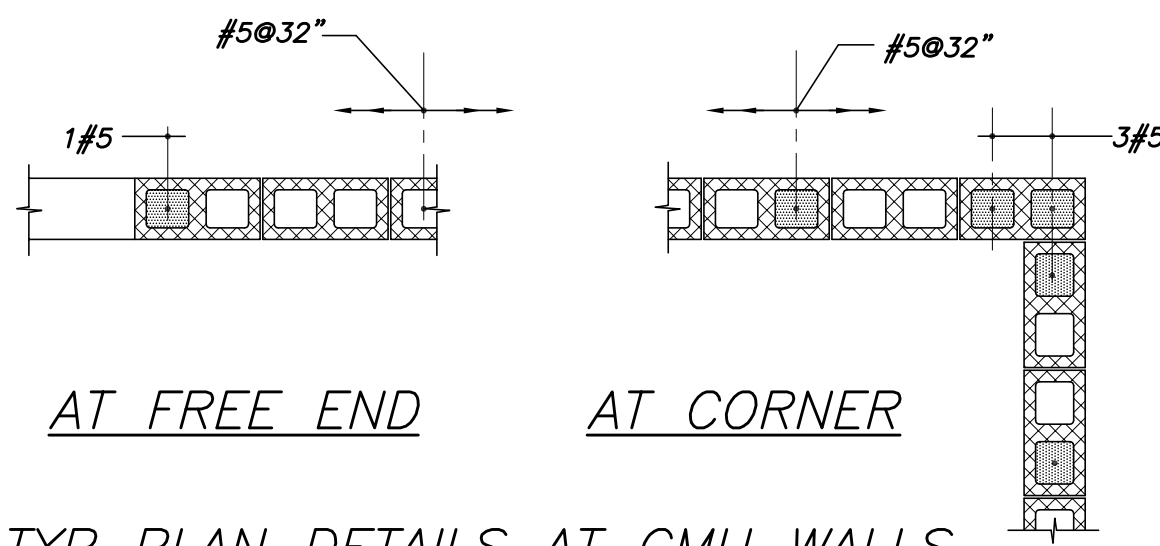

TYP PLAN DETAILS AT CMU WALLS
N.T.S.

- NOTES:**
- 1. PROVIDE TRUSS TIE HORIZ REINF @ 16" O.C., UN.O.
 - 2. ALL REINFORCED CELLS ARE TO BE GROUTED.
 - 3. LAP BARS AT SPLICES. (SEE NOTES DWG S1.0 FOR LAP LENGTH REQNTS.)

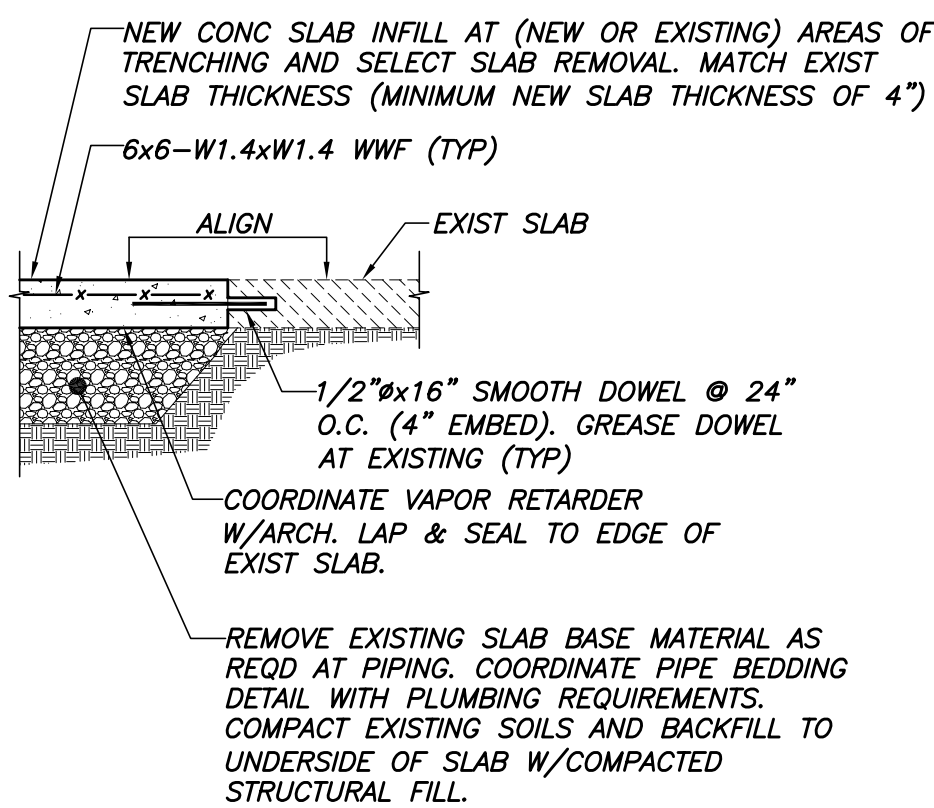

TYPICAL SLAB ON GRADE INFILL DETAIL
1/2"=1'-0"

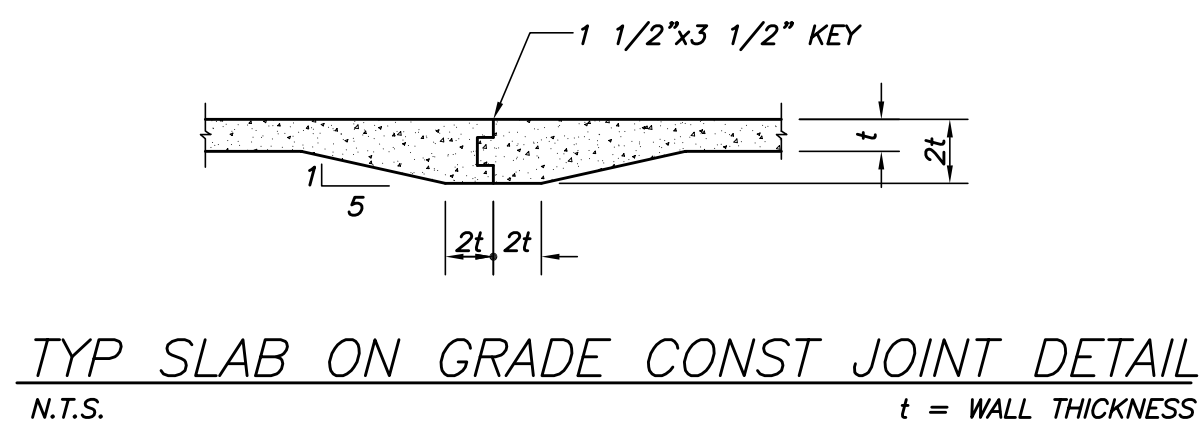

TYP SLAB ON GRADE CONST JOINT DETAIL
N.T.S.

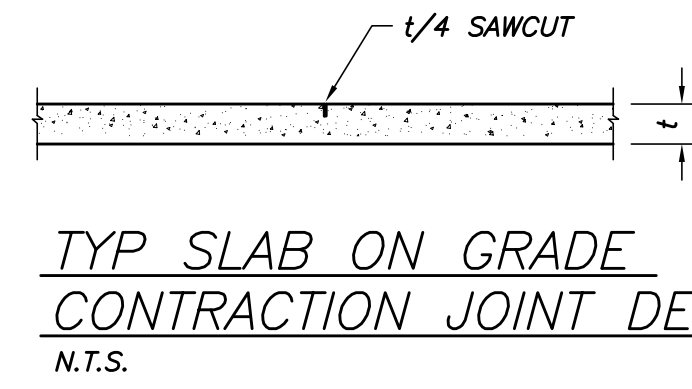

TYP SLAB ON GRADE CONTRACTION JOINT DETAIL
N.T.S.

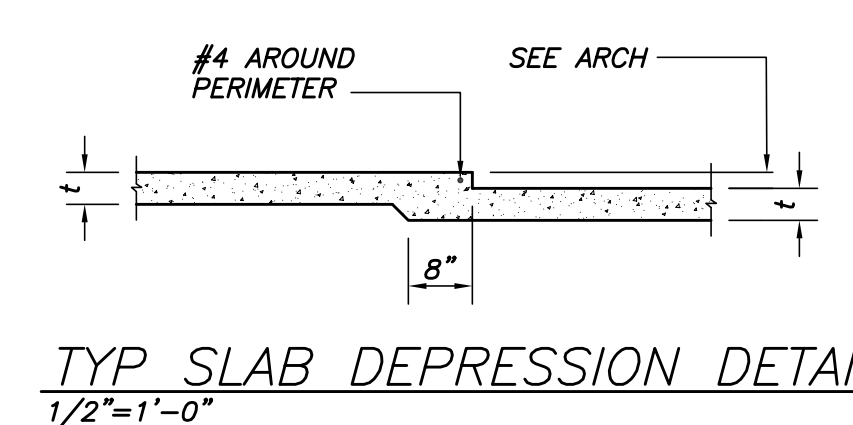

TYP SLAB DEPRESSION DETAIL
1/2"=1'-0"

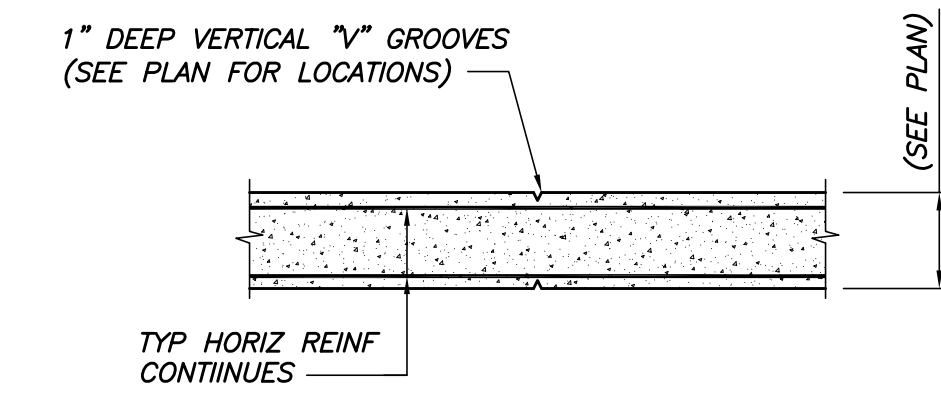

TYP CONTROL JOINT IN WALL
N.T.S.

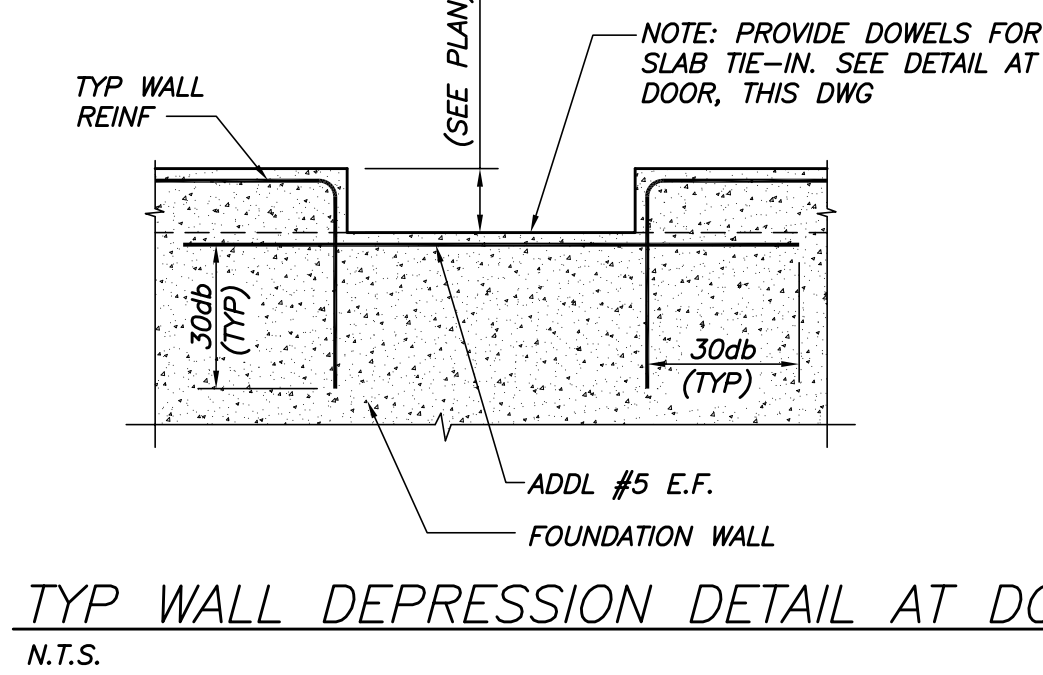

TYP WALL DEPRESSION DETAIL AT DOOR
N.T.S.

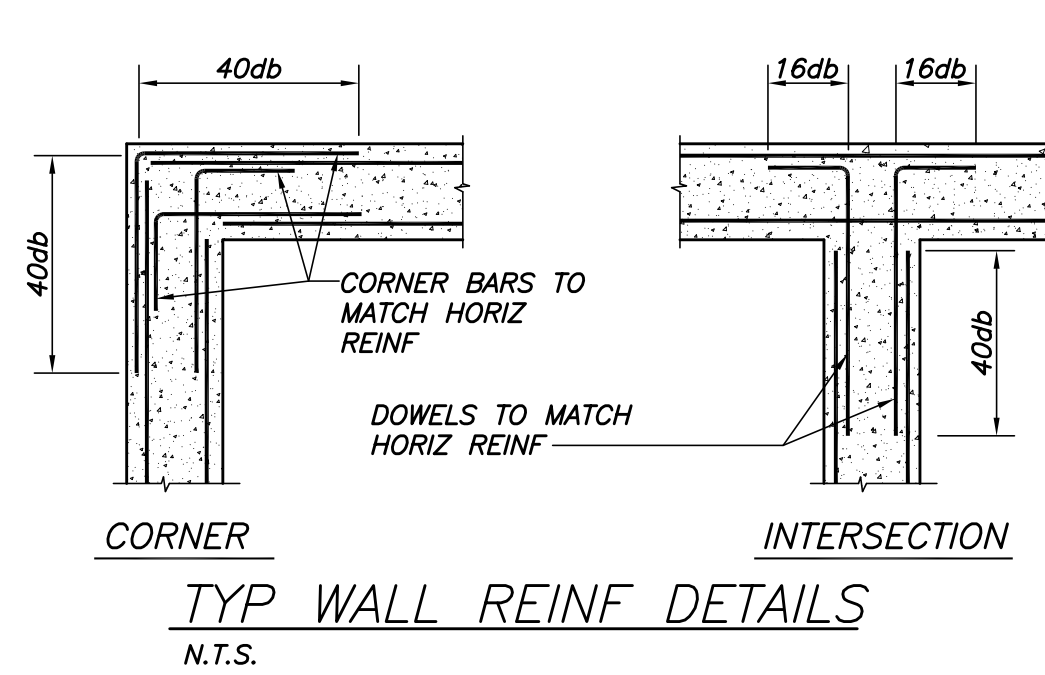

TYP WALL REINF DETAILS
N.T.S.

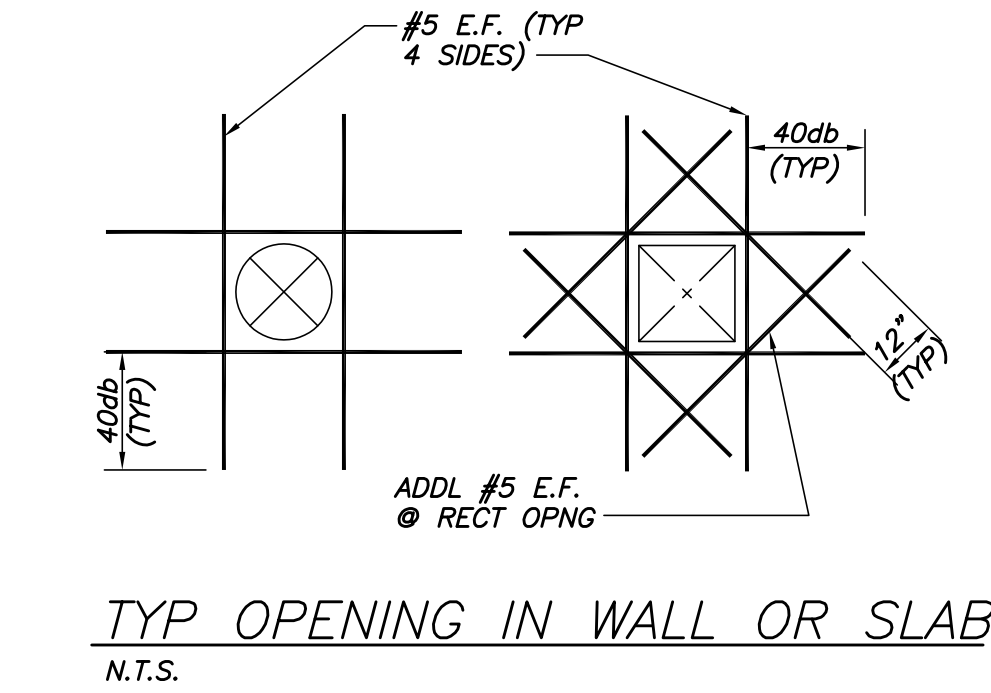

TYP OPENING IN WALL OR SLAB
N.T.S.

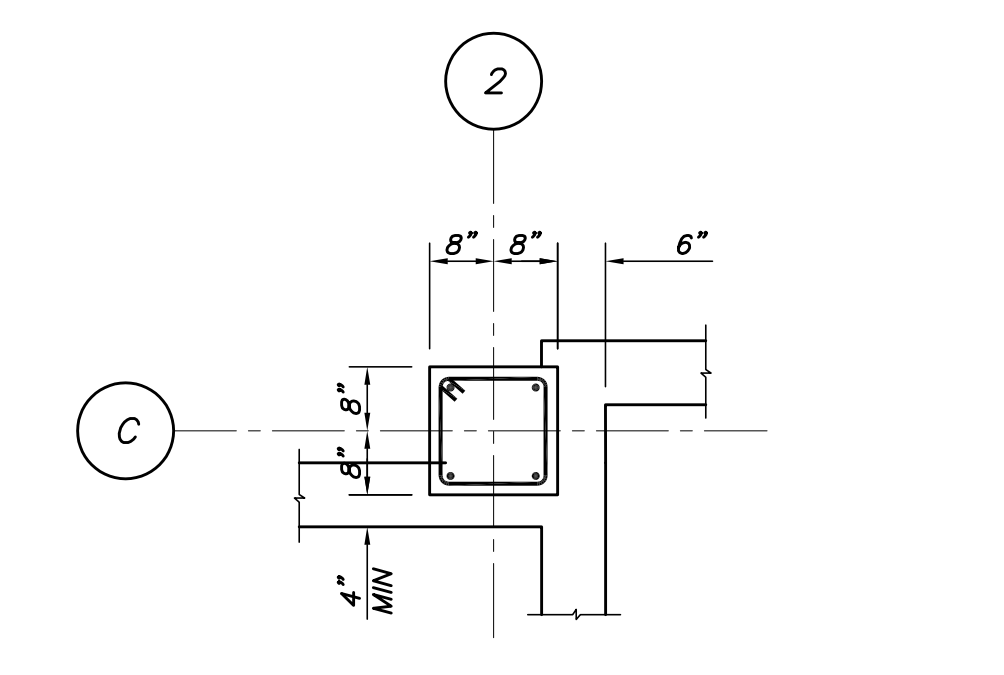

P1

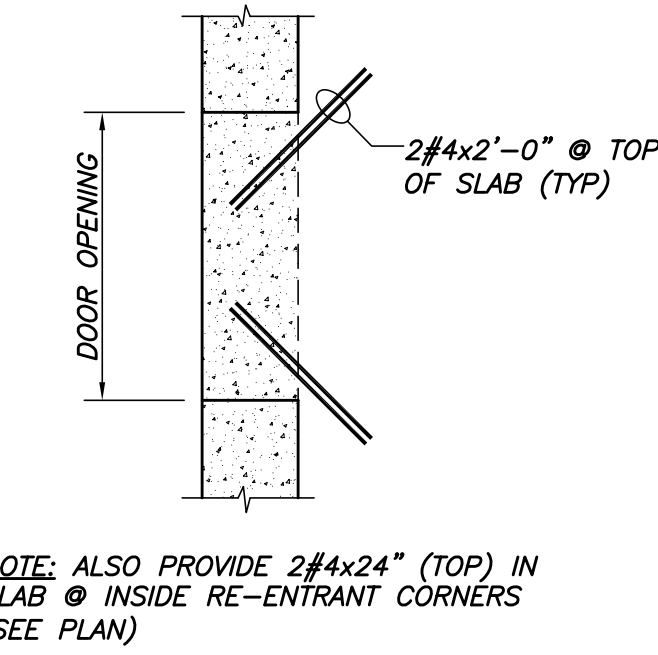

TYP SLAB CORNER DETAIL @ DOOR
N.T.S.

- NOTE:** ALSO PROVIDE 2#4x24" (TOP) IN SLAB @ INSIDE RE-ENTRANT CORNERS (SEE PLAN)

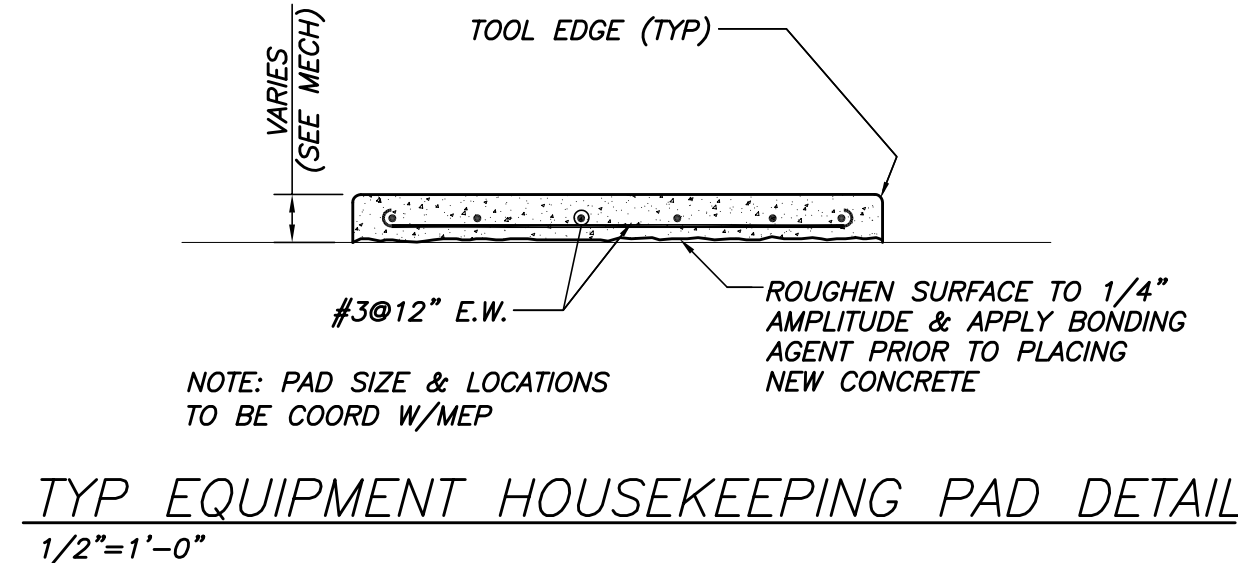

TYP EQUIPMENT HOUSEKEEPING PAD DETAIL
1/2"=1'-0"

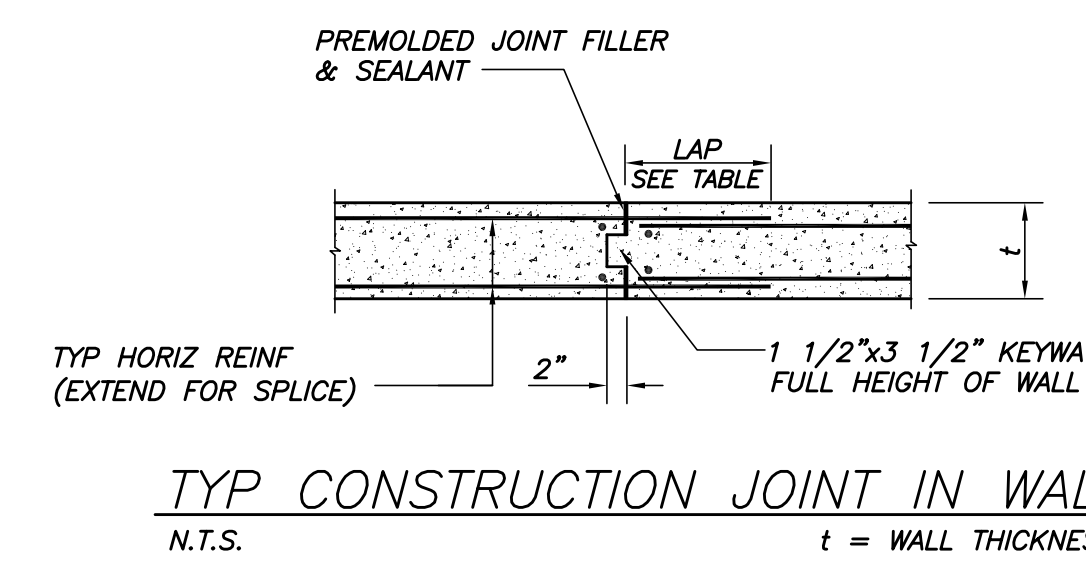

TYP CONSTRUCTION JOINT IN WALL
N.T.S.

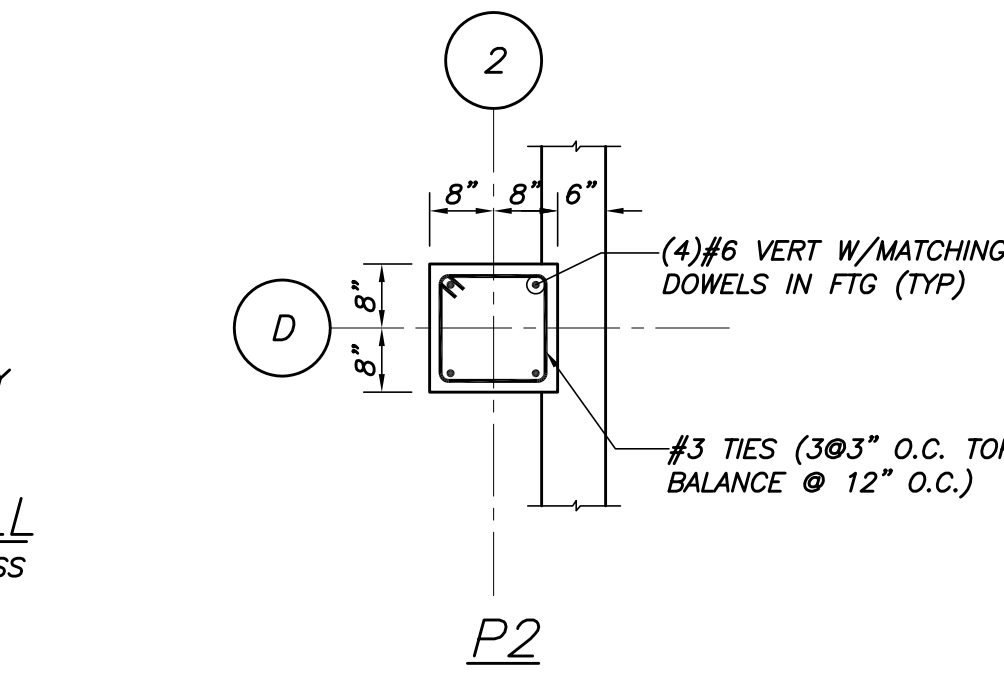

P2

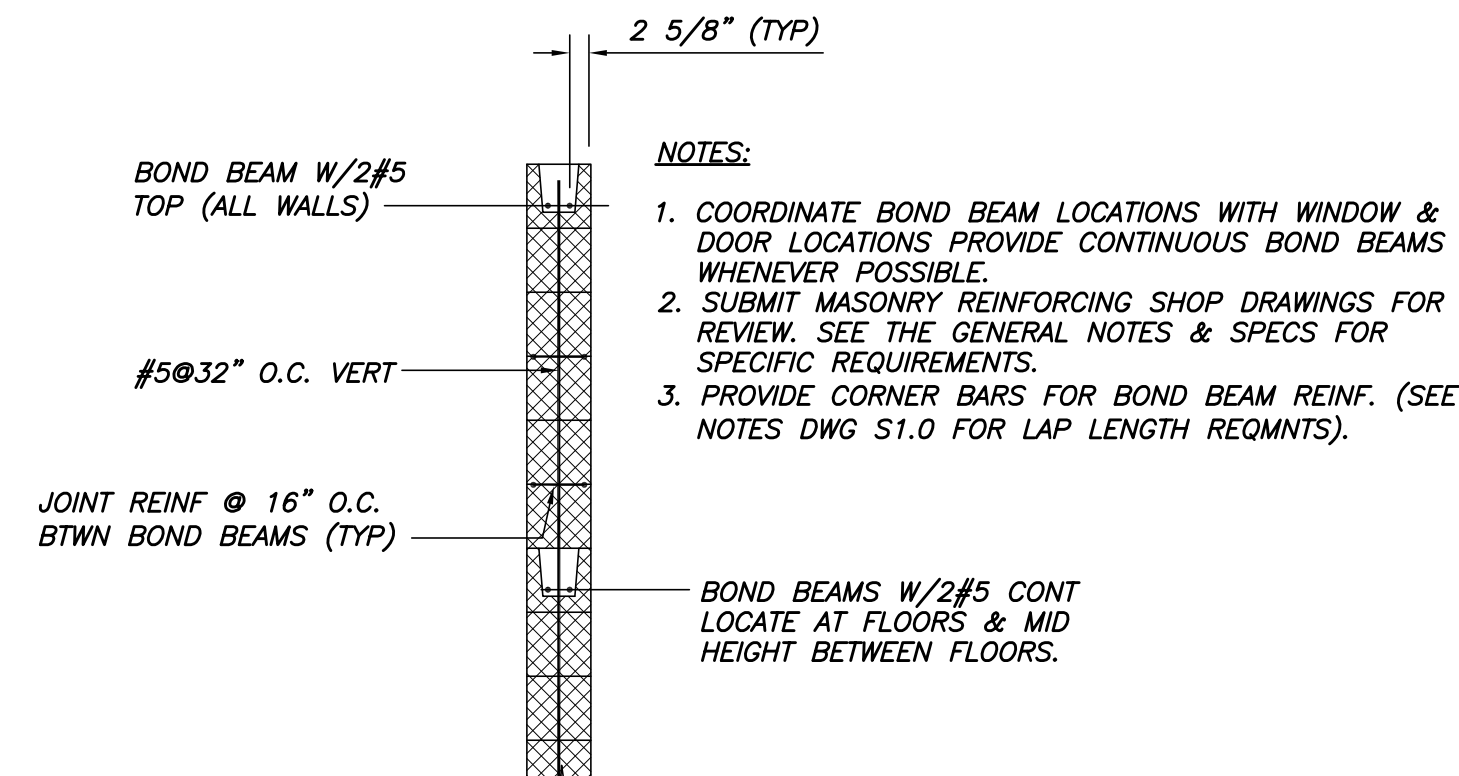

CMU WALL SECTION
N.T.S.

CMU LINTEL SCHEDULE

CLEAR SPAN	WIDTH	DEPTH	REINF
< 6'-0"	8"	8"	2#5 CONT

REBAR LAP SPLICE TABLE

BAR SIZE	LAP LENGTH (3,000 PSI)
#3	30"
#4	36"
#5	48"
#6	64"
#7	81"

- NOTES:**
- 1. COORDINATE BOND BEAM LOCATIONS WITH WINDOW & DOOR LOCATIONS PROVIDE CONTINUOUS BOND BEAMS WHENEVER POSSIBLE.
 - 2. SUBMIT MASONRY REINFORCING SHOP DRAWINGS FOR REVIEW. SEE THE GENERAL NOTES & SPECS FOR SPECIFIC REQUIREMENTS.
 - 3. PROVIDE CORNER BARS FOR BOND BEAM REINF. (SEE NOTES DWG S1.0 FOR LAP LENGTH REQNTS.)

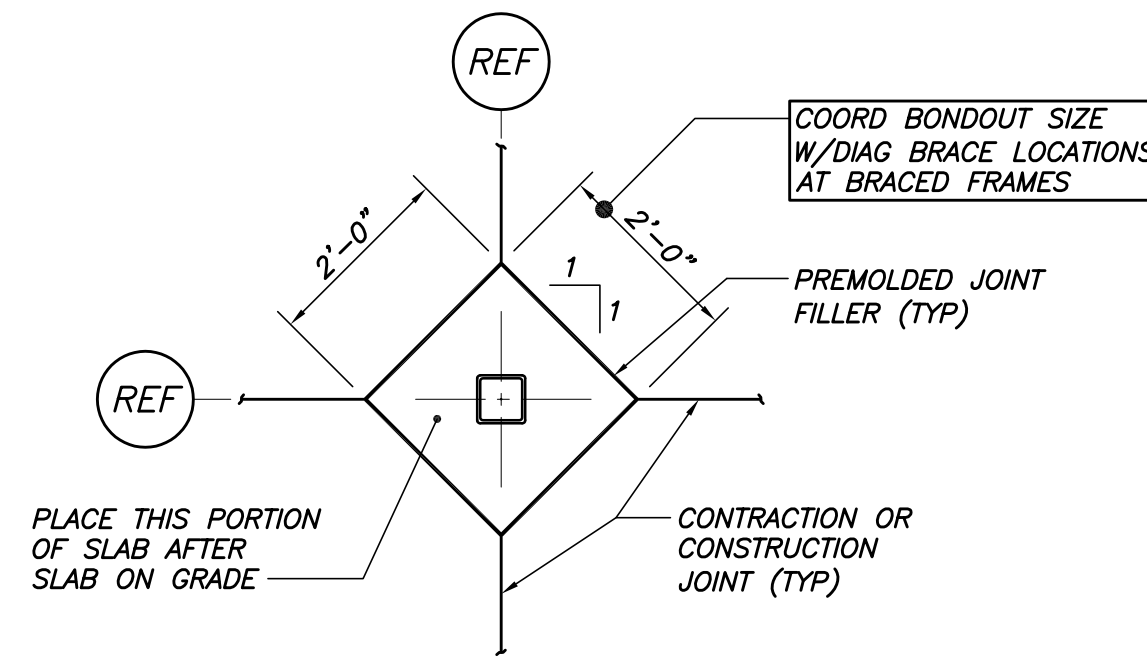

TYP INT COLUMN ISOLATION JOINT DETAIL
N.T.S.

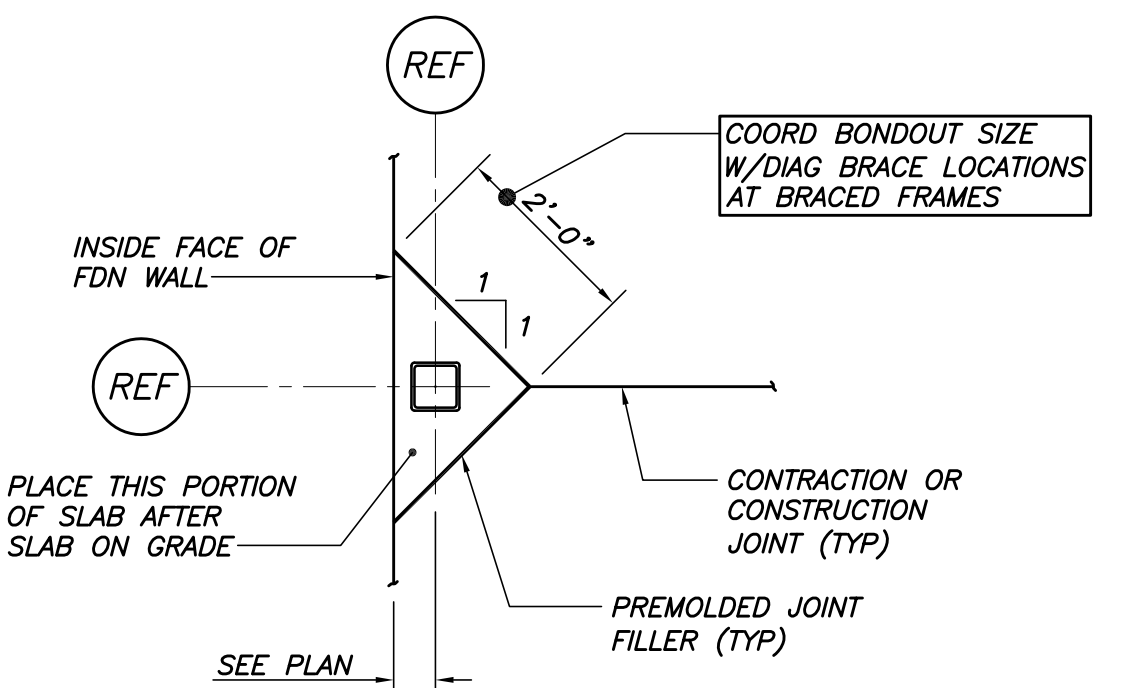

TYP EXT COLUMN ISOLATION JOINT DETAIL
N.T.S.

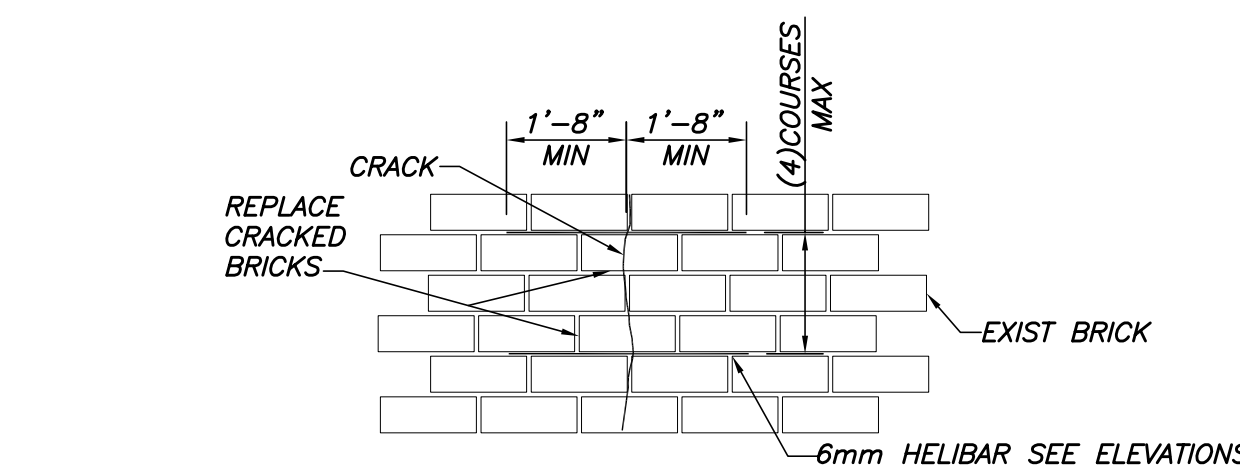

TYP HELIBAR CRACK STITCHING DETAIL

HELIBAR CRACK STITCHING PROCEDURE:

NOTE: CRACK STITCHING APPLIES TO INTERIOR & EXTERIOR WYTHES. COORD WORK WITH NEW LINTEL INSTALLATION & OTHER FACADE RESTORATION WORK. COMPLETE CRACK STITCHING PRIOR TO UNDERPINNING FOUNDATION.

- 1. SPLIT AND CRACKED SECTIONS OF MULTI-WYTHE MASONRY SHOWN ON THE FACADE DRAWINGS TO BE REINFORCED BY MEANS OF A "CRACK STITCHING" TECHNIQUE SHALL UTILIZE THE 6mm HELIBAR 304 STAINLESS STEEL HELICAL ROD AS MANUFACTURED BY HELIFIX NORTH AMERICA, 110 MAPLECRETE ROAD, CONCORD, ONTARIO, CANADA, 888-992-9989.
- 2. RAKE OUT OR SAWCUT SLOTS IN THE HORIZONTAL MORTAR JOINTS A MINIMUM OF 20 INCHES EITHER SIDE OF THE CRACK TO THE DEPTH OF 1 1/2 - 2 INCHES.
- 3. CLEAN OUT THE JOINTS WITH COMPRESSED AIR OR WATER PRIOR TO THE INSTALLATION OF THE CEMENTITIOUS GROUT.
- 4. INJECT CEMENTITIOUS GROUT INTO THE BACK OF THE JOINT WITH A GROUT GUN.
- 5. PUSH THE 6mm HELIBAR INTO THE BACK OF THE JOINT. APPLY A BEAD OF GROUT OVER THE EXPOSED HELIBAR AND "IRON" INTO THE JOINT WITH A FINGER TROWEL.
- 6. REPLACE CRACKED BRICKS (SEE PROJECT SPECIFICATIONS FOR BRICK REQUIREMENTS) & REPOINT ALL AFFECTED JOINTS.
- 7. WHERE THE DISTANCE FROM THE CRACK TO A TERMINATION POINT DOES NOT EXCEED 20 INCHES THE HELIBAR IS TO BE BENT 90° AND INSERTED INTO A 6mm DRILLED HOLE TO A DEPTH OF 3 - 4 INCHES PRIOR TO GROUTING.
- 8. WHERE A CRACK IS LESS THAN 20 INCHES FROM THE END OF A WALL THE HELIBAR SHOULD BE BENT AROUND THE CORNER AND BONDED INTO THE RETURN WALL AT LEAST 6 INCHES.

65 NEWBURY STREET
 PORTLAND, ME 04101
 207.761.9000
 info@portcityarch.com
 WWW.PORTCITYARCH.COM

UNE
 UNIVERSITY OF
 NEW ENGLAND

Allied Engineering
 Structural Mechanical Electrical Commissioning

CONSIGLI
 Est. 1905

BECKER
 STRUCTURAL ENGINEERS

REVISIONS		
No.	Description	Date

PERMIT SET

**UNIVERSITY OF
 NEW ENGLAND**
 PORTLAND, MAINE

**ALUMNI HALL
 RENOVATION**
**FOUNDATION
 DETAILS**

Project Number 3450
 Date May 1, 2015
 Drawn by MSK
 Checked by CGW

S7

Scale AS NOTED