



Permitting and Inspections Department

Fire Alarm Permit Application

Construction Address: 631 Stevens Ave.		
Total Square Footage of Proposed Structure: 9462		
Tax Assessor's Chart, Block & Lot Chart# Block# Lot# <input type="text"/> <input type="text"/> <input type="text"/>		Applicant Name: Norris Inc. Address: 2257 West Broadway South Portland, ME. 04106 Phone: 207-883-3473 Email: melissap@norrisinc.com
Cost of Work: \$ 28000		Contractor Name (if different): Electrical Maintenance & Install Address: PO Box 2730 South portland, ME. 04106 Phone: 878-5000 Email: emistew@aol.com
Lessee/Owner Name (if different): Kevin Bunker Address: 631 Stevens Ave. Phone: <input type="text"/> Email: bunker.kevin@gmail.com		Contractor Name (if different): Electrical Maintenance & Install Address: PO Box 2730 South portland, ME. 04106 Phone: 878-5000 Email: emistew@aol.com
Current use (i.e. single family): <input type="text"/> If vacant, what was the previous use? McCauley HS Proposed specific use: Growing Learners Daycare (1st floor) Is property part of a subdivision? If yes, name: no Project description: install a new addressable fire alarm system for phase 1 growing learners. Life Safety Code Occupancy Classification: new daycare Is this new work or a renovation to an existing system? new Is the top occupiable floor of the building greater than 75 feet above the lowest level of Fire Department access (high-rise)? no Name of company providing programming and certification of system*: Norris Inc. Electrical permit #: ELEC2020-02495		
Will a master box be installed? <input checked="" type="radio"/> Yes <input type="radio"/> No If yes, complete all items for approval): AES approved installing contractor: <input type="text"/> Documentation of AES approval: attached Property Owner: same as above Property Owner Billing Address: <input type="text"/> Property common name: <input type="text"/> E-911 address for protected premises: <input type="text"/> Emergency contact phone: <input type="text"/> Additional emergency contact phone: <input type="text"/> Number of stories protected: 1 Is the building protected by a supervised, automatic sprinkler system? <input checked="" type="radio"/> Yes <input type="radio"/> No		
Name of person to contact when the permit is ready: Melissa Peters-- Norris Inc.		
Address: same as above		
City, State & Zip: <input type="text"/>		
Email Address: melissap@norrisinc.com		Phone: 207-883-3473

*For a list of approved fire alarm companies, see www.portlandmaine.gov/1486/Approved-Fire-Alarm-Companies



Norris Inc.

PO Box 2551
2257 West Broadway
South Portland, ME 04106

1-800-370-3473
fax 207-879-0540

www.norrisinc.com



Reviewed for Code Compliance
Permitting and Inspections Department
Approved with Conditions

05/13/2020

Please complete this form and return to Norris Inc.

Building Owner Information Form

Job Name:

Project #

Electrical Contractor:

NFPA requires this information for proper documentation.

The contractor must provide all of the requested information below before ANY equipment can be released.

Electrical Contractor Contact:

Estimated Date Equip. Needed:

Estimated Finals Date:

Building Owner:

Job Site Address:

City:

State:

Zip:

Customer Contact:

Phone:



Norris Inc.

PO Box 2551
2257 West Broadway
South Portland, ME 04106

1-800-370-3473
Fax 207-879-0540

www.norrisinc.com



Reviewed for Code Compliance
Permitting and Inspections Department
Approved with Conditions

05/13/2020

Thank you for your cooperation.

**Please advise the building owners that if this system is equipped with a digital communicator,
then they MUST also make monitoring arrangements prior to a certificate of occupancy.**

Norris Inc will attempt to contact the building owners.



Norris Inc.

PO Box 2551
2257 West Broadway
South Portland, ME 04106

1-800-370-3473
Fax 207-879-0540

www.norrisinc.com



Reviewed for Code Compliance
Permitting and Inspections Department
Approved with Conditions

05/13/2020

STOP!

**THIS COPY IS FOR YOUR ELECTRICIAN
ON THE JOBSITE**

PLEASE BE SURE THIS COPY IS FORWARDED

- 1.) A riser diagram is enclosed. **DO NOT USE THE ENGINEER'S RISER SHOWN ON THE PLANS.** If there is any information that you question, call us immediately.
- 2.) **YOU MUST CALL AT LEAST FIVE DAYS IN ADVANCE TO SCHEDULE FINAL CONNECTION ASSISTANCE.**
- 3.) All wires must be labeled and clear of any grounds, shorts or opens, and must maintain polarity throughout. Meter out all circuits before calling for final connection assistance. If applicable verify End of Line resistors are in place.
- 4.) If using shielded cable, the drain wires must be connected and fully insulated, so that neither the shield or the drain wire touches the backbox.
- 5.) Unless special arrangements are made, we will make one final job site visit. If a special visit is required for an elevator inspection or partial occupancy, then additional charges may if prior arrangements were not made. Call your customer service representative if needed.
- 6.) If you have any defective or left over parts, **DO NOT WRITE ON THEM OR THE BOXES.** Save the original box, all mounting hardware and instructions. Returns that do not conform to this practice will not be accepted for credit.
- 7.) If the system is being monitored through a digital communicator, please see information on the next page.



**IMPORTANT INFORMATION FOR THE BUILDING OWNERS
SPECIAL NOTE REGARDING ALARM MONITORING SERVICES**

Included with your alarm system package is a digital communicator, which sends coded messages to a private 24 hour central station if your alarm system is activated. This is a code requirement for most fire alarm systems. As a service to our customer, we offer central station monitoring services from our local UL Listed central station at extremely competitive rates.

If the central station monitoring contract is purchased through Norris Inc. prior to our scheduled start up; we will connect, program, and test the communicator at no additional charge.

Should the building owners decide to obtain monitoring services from another company, then the cost for programming and testing the communicator will be the sole responsibility of the firm they have contracted with. Furthermore, if programming changes are made to the system by persons other than Norris Inc. technicians, then the company performing the changes shall be solely liable for any personal injury or loss of life or damage to, or loss of property arising out of the use of or inability to use the system and it shall result in a waiver of any system warranties.

We appreciate that you understand the delicate nature of this life safety and/or security system and realize that serious problems may arise when modifications to the system are made, including very simple programming changes.

Call Norris Inc. at 1-800-370-FIRE (3473) to make arrangements for central station monitoring services.



Norris Inc.

PO Box 2551
2257 West Broadway
South Portland, ME 04106

1-800-370-3473
Fax 207-879-0540

www.norrisinc.com



Reviewed for Code Compliance
Permitting and Inspections Department
Approved with Conditions

05/13/2020

SUBMITTAL PACKAGE

Project: Growing Learners

System: Fire Alarm

Submitted by: Norris Inc.

2257 West Broadway

South Portland, Maine 04106

Telephone: 1-800-370-3473

Submittal Date: 4/24/2020



Company Profile

“We are extremely proud to represent the highest quality manufacturers integrating life safety, alarm, and communication systems throughout northern New England.”

—Bradford Norris, President—

Mission Statement

Provide quality engineered systems, exceptional service.

Goal

Learn...Continually Improve...Exceed Expectations

Founded in 1979, Norris Inc. has grown to become northern New England’s leading integrated system contracting and supply company. Norris Inc. is an innovated proactive organization with extensive experience in integration interdisciplinary building management systems. Our local and national affiliations assure that your project will be done properly regardless of size. Representing leading manufacturers, our comprehensive projects provide outstanding quality, reliability, and performance... Surpassing customer application requirements and exceeding the stringent requirements of Underwriters Laboratories, National Fire Protection Association and other codes.

We maintain an exceptional level of quality and provide the highest levels of customer service. Our knowledgeable technical support will insure the great service you deserve.

Whether your needs involve industrial, commercial, institutional, or educational applications, you can trust that Norris Inc. has the complete resources it takes to provide the right solution, right away.



LIMITED WARRANTY

Norris Inc. warrants that the products of its manufacturers shall be free from defects in materials or workmanship as warranted by the manufacturer which is typically for a one (1) year period from the completed installation date, but not always. The completed installation date will be the date when the end-user was able to begin using or started using the product(s) or the system, whether partially or in its entirety. For projects that have a specification or bid instructions to follow which contains specific warranty requirements, Norris Inc. will always honor the warranty terms exactly as specified in the project's specifications or bid documents, which may be more or less in coverage and duration than the manufacturer's warranty. In performing hundreds of projects per year with thousands of different products it is impossible for Norris Inc. to track the terms and details of specified or individual product warranties. Therefore, Norris Inc. will request that the owner's representative provide these special warranty details when the warranty work is requested; otherwise a standard one (1) year warranty on the equipment will be honored. The manufacturer's warranty is for equipment only and does not include any labor and/or shipping costs. All warranties provided by Norris Inc. are limited with the same limitations included with the manufacturer's warranty which is included in the manuals of the products being provided.

The warranty will apply only if such goods have been properly installed, are subject to normal proper use and have not been modified in any manner whatsoever. Upon return of the defective product, Norris Inc. will, at its sole discretion, either repair or replace, at no cost, such goods determined to have a defect in materials or workmanship. In cases of a warranty repair, Norris Inc. will use its sole discretion to determine if a suitable replacement part can be provided on loan while the repairs are being performed.

All warranty work is performed during regular business hours. If emergency warranty work is required, the customer will pay the difference between the emergency service bill and our normal hourly charges.

Norris Inc.'s limited warranty does not apply to those products that are damaged due to misuse, abuse, negligence, exposure to adverse environmental conditions, acts of God, or have been modified in any manner whatsoever.

Norris Inc.'s standard terms and conditions are provided with our invoices. Those Terms and Conditions shall be provided upon request.

NORRIS INC. SHALL NOT UNDER ANY CIRCUMSTANCES BE LIABLE FOR ANY INCIDENTAL OR CONSEQUENTIAL DAMAGES ARISING FROM LOSS OF LIFE AND/OR PROPERTY OR OTHER DAMAGE OR LOSSES OWING TO THE FAILURE OF NORRIS INC. PRODUCTS BEYOND THE COST OF REPAIR OR REPLACEMENT OF ANY DEFECTIVE PRODUCTS.

NORRIS INC. MAKES NO WARRANTY OF FITNESS OR MERCHANTABILITY AND NO OTHER WARRANTY, ORAL OR WRITTEN, EXPRESS OR IMPLIED AS ALLOWED TO THE FULLEST EXTENT OF THE LAW.



OUR CONTINUOUS COMMITMENT TO OUR ENVIRONMENT

Reviewed for Code Compliance
Permitting and Inspections Department
Approved with Conditions

05/13/2020

At Norris Inc, we are proudly committed to continuous environmental improvement for a sustainable future and to develop strong partnerships within our community.

Our mission while running our operations is to do everything within our power to improve the environmental quality of our world and to work together to create a clean and safe place to live in and work in for future generations.

We will incorporate and promote green practices within our operations with policies to support it, a system of rewarding those that fully embrace it and then will regularly review our practices for continuous improvement.

We will establish policies, make investments in technologies and set the example in our own operations to include our ongoing commitment to go paperless and making it a requirement to Reuse, Reduce, & Recycle, to turn off unneeded lights, to not allow our vehicles to idle, to encourage carpooling and to utilize practical energy efficient transportation.

We will always be 100% compliant with all applicable environmental laws and regulations and will report any violations.

We will remain committed to working locally and whenever possible to sell and use locally manufactured products.

We will insist that every purchase we make will include a review of its environmental impact with a very high priority to selecting the greenest products and services available.

We will remain committed to selling low energy products. This includes promoting wireless technologies, using existing wire infrastructure in our installations, promoting solar powered devices, using our Remote Services in lieu of on-site service calls and performing calculations to minimize power supply and battery needs.

We will educate our employees and customers to illustrate that green practices and purchases are almost always less costly in the long run.

We will support and give priority to organizations that show the strongest commitment to the environment.

We will actively encourage and promote the same responsible green practices that we utilize in the work place to our employees for use in their everyday personal lives.



REMOTE INTERNET CONNECTIONS

As an added service to our customers and in order to facilitate the commissioning of the system(s) being provided within this submittal and then later to provide warranty support Norris Inc. may (at Norris Inc's option) use internet connections to gain access to the system(s) being provided. Many methods can be used, but the most popular is utilizing software named LogMeIn. This software or any other method used to connect to the customer's network will allow Norris Inc's technicians the ability to get onto the programming and diagnostic levels of the system(s) being provided via the building owner's or tenant's data network and program, diagnose or make needed changes to the operation of the system(s). This will provide a better working atmosphere to perform programming from a controlled environment without the disruptions of a construction job-site and allow fast and efficient trouble shooting and/or servicing if problems should occur later. Acceptance of this submittal by those approving it shall constitute an acceptance and approval to perform the work necessary to install and/or enable these network connections if Norris Inc. chooses to do so. It is the sole responsibility of the submittal approvers to advise the building owners and/or tenants that Norris Inc. has the ability to gain access to their network. At the specific request of those approving this submittal or the contractor that Norris Inc. is working for the building owners or tenants that own the network, Norris Inc. can remove or disable the ability to connect to the building's network. However, leaving it in place will allow for quicker and more cost effective service when it is needed. Under absolutely no circumstances shall Norris Inc, its principals, employees, or heirs to be held responsible for any losses incurred as a result of this network connection or the inability for the network connection to operate as expected.



Reviewed for Code Compliance
Permitting and Inspections Department
Approved with Conditions

05/13/2020

This is to certify that

NORRIS, INC.

is an authorized Premier Engineered Systems Distributor for
NOTIFIER

During the year of 2020

Richard Bauer
Vice President Sales

ESD Since 1987

Growing Learners



Reviewed for Code Compliance
Permitting and Inspections Department
Approved with Conditions

05/13/2020

Date:

4/24/2020

Project #:

1704

Contractor:

Electrical Maint & Install, Inc.
(207) 878-5000

Equipment List

<u>Manufacturer</u>	<u>Part Number</u>	<u>Description</u>
NOTIFIER	NFS320	ADDRESSABLE FIRE ALARM PANEL
NOTIFIER	UDACT2	UNIVERSAL DIGITAL ALARM COMMUNICTATOR TRANSMITTER
SR COMPONENTS	804R8	SILVER SATIN 8' PLUG - PLUG
SR COMPONENTS	RJ31X	UL 8P8C RJ31X JACK
SIGMASTEK	SP1226	12V 26AH BATTERY
NOTIFIER	FDU80	80 CHARACTER DISPLAY ANNUNCIATOR
NOTIFIER	SBB3	SURFACE MOUNT BACK BOX, ANNUNCIATOR
NOTIFIER	NBG12LX	ADDRESSABLE PULL STATION
NOTIFIER	FSP951	ADDRESSABLE PHOTO DETECTOR
NOTIFIER	FST951H	ADDRESSABLE HEAT DETECTOR, HIGH TEMP
NOTIFIER	B3006	ADDRESSABLE BASE
NOTIFIER	FCO951IV	SMOKE/CO- IVORY
NOTIFIER	B200SIV	ADDRESSABLE SOUNDER BASE, IVORY
NOTIFIER	FMM101	ADDRESSABLE MINI MODULE
NOTIFIER	FRM1	ADDRESSABLE RELAY
NOTIFIER	XP6MA	ADDRESSABLE ZONE MODULE (6 ZONE)
NOTIFIER	BBXP	CABINET FOR XP MODULE
NOTIFIER	FCPS24S8	8.0 AMPS, 120 VAC REMOTE CHARGER POWER SUPPLY
SIGMASTEK	SP127	12V 7AH BATTERY
GENTEX CORP.	GEC324WR	HORN STROBE, WALL, RED
GENTEX CORP.	GES3-24WR	STROBE, WALL, RED
SPACE AGE	ELOCKFA	FIRE CIRCUIT LOCK OUT KIT
SPACE AGE	SSU00690	FIRE ALARM RECORDS CABINET
AES	7788F	8 ZONE RADIO MASTER BOX 453.1125 PORTLAND
ELK PRODUCTS,INC.	TRG1640	16.5VAC, 45VA TRANSFORMER
SENTROL	SR3025TM	BOX TAMPER
KNOX	KNOX3261	BLACK KNOX BOX, HINGED

NFS-320

Intelligent Addressable Fire Alarm System



Intelligent Fire Alarm Control Panels

General

The NFS-320 intelligent Fire Alarm Control Panel is part of the ONYX® Series of Fire Alarm Controls from NOTIFIER.

In stand-alone or network configurations, ONYX Series products meet virtually every application requirement.

The NFS-320's modular design makes system planning easier. The panel can be configured with just a few devices for small building applications, or networked with many devices to protect a large campus or a high-rise office block. Simply add additional peripheral equipment to suit the application. Wireless fire protection can be added with the SWIFT wireless gateway and devices.

For installations using NFS-320C, an optional ACM Series annunciator can be mounted in the same cabinet (up to 48 zones/points, order separately; see DN-60085).

NOTE: Unless called out with a version-specific "R", "C" or "E" at the end of the part number, "NFS-320" refers to models NFS-320, NFS-320R, NFS-320C, and NFS-320E.



NFS-320

Features

- Certified for seismic applications when used with the appropriate seismic mounting kit.
- Approved for Marine applications when used with listed compatible equipment. See DN-60688.
- One isolated intelligent Signaling Line Circuit (SLC) Style 4, 6 or 7.
- Up to 159 detectors and 159 modules per SLC; 318 devices maximum.
 - Detectors can be any mix of ion, photo, thermal, or multi-sensor; wireless detectors are available for use with the FWSG.
 - Modules include addressable pull stations, normally open contact devices, two-wire smoke detectors, notification, or relay; wireless modules are available for use with the FWSG.
- Optional FWSG Wireless SWIFT Gateway supports wireless SLC devices.
- Standard 80-character display.
- Network options:
 - High-speed network for up to 200 nodes (NFS2-3030, NFS2-640, NFS-320(C), NFS-320SYS, NCA-2, DVC-EM, ONYX-Works, NFS-3030, NFS-640, and NCA).
 - Standard network for up to 103 nodes (NFS2-3030, NFS2-640, NFS-320(C), NFS-320SYS, NCA-2, DVC-EM, ONYX-Works, NCS, NFS-3030, NFS-640, NCA, AFP-200, AFP-300/400, AFP-1010, and AM2020). Up to 54 nodes when DVC-EM is used in network paging.
- 6.0 A power supply with four Class A/B built-in Notification Appliance Circuits (NAC). Selectable System Sensor, Wheelock, or Gentex strobe synchronization.
- Built-in Alarm, Trouble, Security, and Supervisory relays.
- VeriFire® Tools online or offline programming utility. Upload/Download, save, store, check, compare, and simulate panel databases. Upgrade panel firmware.
- Autoprogramming and Walk Test reports.
- Multiple central station communication options:
 - Standard UDACT
 - Internet
 - Internet/GSM
- 80-character remote annunciators (up to 32).
- EIA-485 annunciators, including custom graphics.
- Printer interface (80-column and 40-column printers).
- History file with 800-event capacity in nonvolatile memory, plus separate 200-event alarm-only file.

- Alarm Verification selection per point, with automatic counter.
- Presignal/Positive Alarm Sequence (PAS).
- Silence inhibit and Auto Silence timer options.
- NAC coding functions:
 - March time.
 - Temporal.
 - California two-stage coding.
 - Canadian two-stage.
 - Strobe synchronization.
- Field-programmable on panel or on PC with VeriFire® Tools program check, compare, simulate.
- Full QWERTY keypad.
- Battery charger supports 18 – 200 AH batteries.
- Non-alarm points for lower priority functions.
- Remote ACK/Signal Silence/System Reset/Drill via monitor modules.
- Automatic time control functions, with holiday exceptions.
- Extensive, built-in transient protection.
- Powerful Boolean logic equations.



Reviewed for Code Compliance
Permitting and Inspections Department
Approved with Conditions

05/13/2020

FLASHSCAN® INTELLIGENT FEATURES

- Polls up to 318 devices in less than two seconds.
- Activates up to 159 outputs in less than five seconds.
- Multicolor LEDs blink device address during Walk Test.
- Fully digital, high-precision protocol (U.S. Patent 5,539,389).
- Manual sensitivity adjustment — up to nine levels.
- Pre-alarm ONYX intelligent sensing — up to nine levels.
- Day/Night automatic sensitivity adjustment.
- Sensitivity windows:
 - Ion – 0.5 to 2.5%/foot obscuration.
 - Photo – 0.5 to 2.35%/foot obscuration.
 - Laser (VIEW®) – 0.02 to 2.0%/foot obscuration.
 - Acclimate® Plus™ – 0.5 to 4.0%/foot obscuration.
 - IntelliQuad – 1.0 to 4.0%/foot obscuration.
 - IntelliQuad™ PLUS – 1.0 to 4.0%/foot obscuration
- Drift compensation (U.S. Patent 5,764,142).
- Degraded mode — in the unlikely event that the NFS-320's primary microprocessor fails, FlashScan detectors revert to degraded operation and can activate the control panel's NAC circuits and alarm relay. Each of the four built-in panel circuits includes a Disable/Enable switch for this feature.

- Multi-detector algorithm involves nearby detectors in alarm decision (U.S. Patent 5,627,515).
- Automatic detector sensitivity testing (NFPA-72 compliant).
- Maintenance alert (two levels).
- Self-optimizing pre-alarm.

FSL-751 VIEW (VERY INTELLIGENT EARLY WARNING)

SMOKE DETECTION TECHNOLOGY

- Advanced ONYX intelligent sensing algorithms differentiate between smoke and non-smoke signals (U.S. Patent 5,831,524).
- Addressable operation pinpoints the fire location.
- Early warning performance comparable to the best aspiration systems at a fraction of the lifetime cost.

FAPT-851 ACCLIMATE® PLUS™

LOW-PROFILE INTELLIGENT MULTI-SENSOR

- Detector automatically adjusts sensitivity levels without operator intervention or programming. Sensitivity increases with heat.
- Microprocessor-based technology; combination photo and thermal technology.
- Low-temperature warning signal at 40°F ± 5°F (4.44°C ± 2.77°C).

FSC-851 INTELLIQUAD

ADVANCED MULTI-CRITERIA DETECTOR

- Detects all four major elements of a fire (smoke, heat, CO, and flame).
- Automatic drift compensation of smoke sensor and CO cell.
- High nuisance-alarm immunity.

INTELLIGENT FAAST® DETECTORS FSA-5000, FSA-8000, FSA-20000 AND FSA-20000P

- Connects directly to the SLC loop of compatible ONYX series panels.
- Provides five event thresholds that can be individually programmed with descriptive labels for control-by-event programming; uses five detector addresses.

- Uses patented particle separator and field-replaceable filter to remove contaminants.
- Advanced algorithms reject common nuisance conditions
- FSA-5000 covers 5,000 square feet through one pipe.
- FSA-8000 covers 8,000 square feet through one pipe.
- FSA-20000 covers 28,800 square feet through one to four pipes.
- FSA-20000P covers 28,800 square feet through one to four pipes. Supports addressable pipes to pinpoint location of alarm events.

FCO-851 INTELLIQUAD™ PLUS

ADVANCED MULTI-CRITERIA FIRE/CO DETECTOR

- Detects all four major elements of a fire.
- Separate signal for life-safety CO detection.
- Optional addressable sounder base for Temp-3 (fire) or Temp-4(CO) tone.
- Automatic drift compensation of smoke sensor and CO cell.
- High nuisance-alarm immunity.

SWIFT WIRELESS

- Self-healing mesh wireless protocol.
- Each SWIFT Gateway supports up to 50 devices: 1 wireless gateway and up to 49 SWIFT devices.
- Up to 4 wireless gateways can be installed with overlapping network coverage.

RELEASING FEATURES

- Ten independent hazards.
- Sophisticated cross-zone (three options).
- Delay timer and Discharge timers (adjustable).
- Abort (four options).
- Low-pressure CO2 listed.

VOICE FEATURES

- Integrates with FirstCommand Series. See DN-60772.
- Telephone applications require NFC-FFT.



Reviewed for Code Compliance
Permitting and Inspections Department
Approved with Conditions

05/13/2020

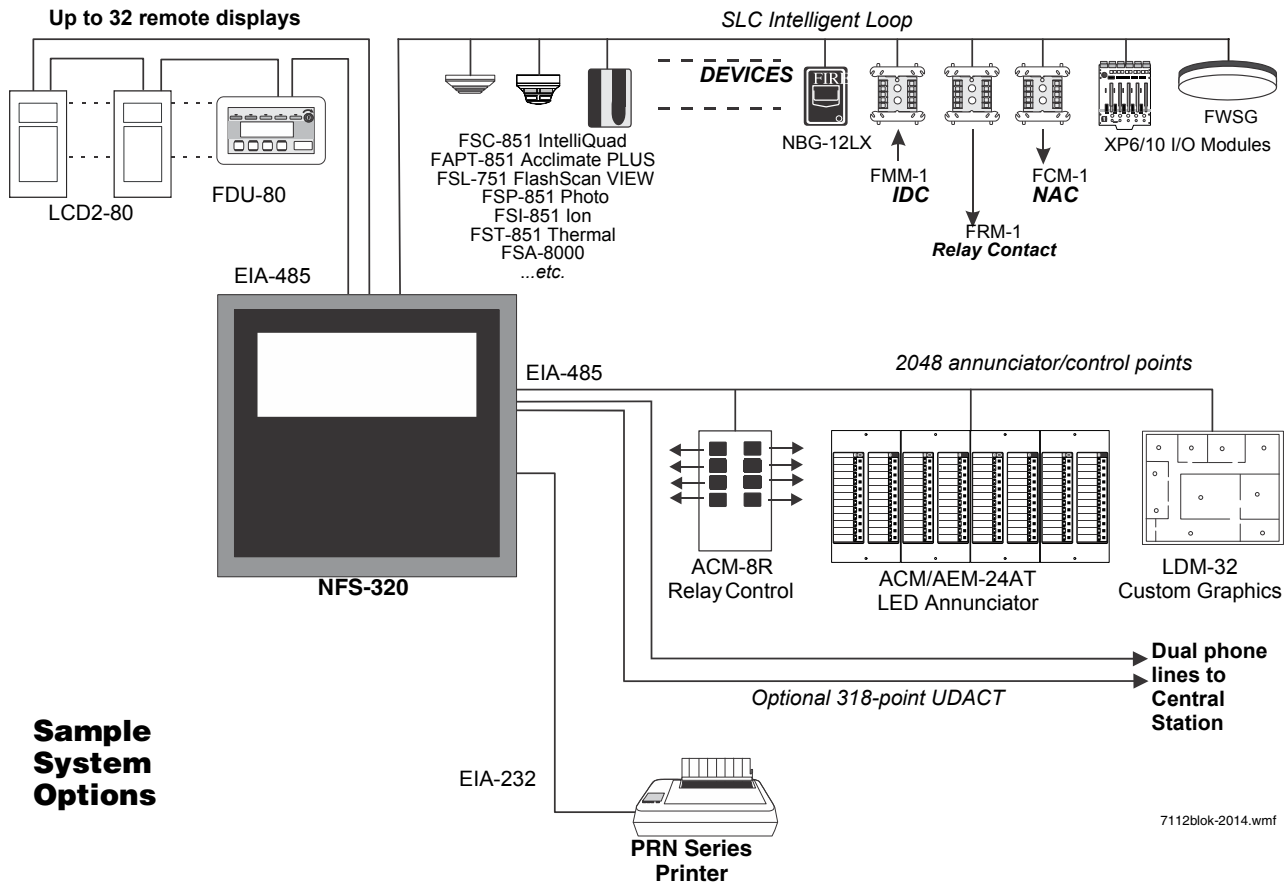

Sample System Options

7112blok-2014.wmf

HIGH-EFFICIENCY OFFLINE SWITCHING
3.0 A POWER SUPPLY (6.0 A IN ALARM)

- 120 VAC (NFS-320/NFS-320C); 240 VAC (NFS-320E).
- Displays battery current/voltage on panel (with display).

FlashScan, Exclusive World-Leading Detector Protocol

At the heart of the NFS-320 is a set of detection devices and device protocol — FlashScan (U.S. Patent 5,539,389). FlashScan is an all-digital protocol that gives superior precision and high noise immunity.

In addition to providing quick identification of an active input device, this protocol can also activate many output devices in a fraction of the time required by competitive protocols. This high speed also allows the NFS-320 to have the largest device per loop capacity in the industry — 318 points — yet every input and output device is sampled in less than two seconds. The microprocessor-based FlashScan detectors have bicolor LEDs that can be coded to provide diagnostic information, such as device address during Walk Test.

ONYX Intelligent Sensing

Intelligent sensing is a set of software algorithms that provides the NFS-320 with industry-leading smoke detection capability. These complex algorithms require many calculations on each reading of each detector, and are made possible by the high-speed micro-computer used by the NFS-320.

Drift Compensation and Smoothing: Drift compensation allows the detector to retain its original ability to detect actual smoke, and resist false alarms, even as dirt accumulates. It reduces maintenance requirements by allowing the system to automatically perform the periodic sensitivity measurements required by NFPA 72. Smoothing filters are also provided by software to remove transient noise signals, such as those caused by electrical interference.

Maintenance Warnings: When the drift compensation performed for a detector reaches a certain level, the performance of the detector may be compromised, and special warnings are given. There are three warning levels: (1) Low Chamber value; (2) Maintenance Alert, indicative of dust accumulation that is near but below the allowed limit; (3) Maintenance Urgent, indicative of dust accumulation above the allowed limit.

Sensitivity Adjust: Nine sensitivity levels are provided for alarm detection. These levels can be set manually, or can change automatically between day and night. Nine levels of pre-alarm sensitivity can also be selected, based on predetermined levels of alarm. Pre-alarm operation can be latching or self-restoring, and can be used to activate special control functions.

Self-Optimizing Pre-Alarm: Each detector may be set for “Self-Optimizing” pre-alarm. In this special mode, the detector “learns” its normal environment, measuring the peak analog readings over a long period of time, and setting the pre-alarm level just above these normal peaks.

Cooperating Multi-Detector Sensing: A patented feature of ONYX intelligent sensing is the ability of a smoke sensor to consider readings from nearby sensors in making alarm or pre-alarm decisions. Without statistical sacrifice in the ability to resist false alarms, it allows a sensor to increase its sensitivity to actual smoke by a factor of almost two to one.

Field Programming Options

Autoprogram is a timesaving feature. The FACP “learns” what devices are physically connected and automatically loads them in the program with default values for all parameters. Requiring less than one minute to run, this routine allows the user to have almost immediate fire protection in a new installation, even if only a portion of the detectors are installed.

Keypad Program Edit (with KDM-R2) The NFS-320, like all NOTIFIER intelligent panels, has the exclusive feature of program creation and editing capability from the front panel keypad, while continuing to provide fire protection. The architecture of the NFS-320 software is such that each point entry carries its own program,

including control-by-event links to other points. This allows the program to be entered with independent per-point segments, while the NFS-320 simultaneously monitors other (already installed) points for alarm conditions.

VeriFire® Tools is an offline programming and test utility that can greatly reduce installation programming time, and increase confidence in the site-specific software. It is Windows®-based and provides technologically advanced capabilities to aid the installer. The installer may create the entire program for the NFS-320 in the comfort of the office, test it, store a backup file, then bring it to the site and download from a laptop into the panel.

Placement of Equipment in Chassis and Cabinet

The following guidelines outline the NFS-320’s flexible system design.

Wiring: When designing the cabinet layout, consider separation of power-limited and non-power-limited wiring as discussed in the *NFS-320 Installation Manual*.

It is critical that all mounting holes of the NFS-320 are secured with a screw or standoff to ensure continuity of Earth Ground.

Networking: If networking two or more control panels, each unit requires a Network Communication Module or High-Speed Network Communication Module (HS-NCM can support two nodes; see “Networking Options” on page 4). These modules can be installed in any option board position (see manual), and additional option boards can be mounted in front of them.

KDM-R2 Controls and Indicators

Program Keypad: QWERTY type (keyboard layout).

12 LED Indicators: Power; Fire Alarm; Pre-Alarm; Security; Supervisory; System Trouble; Signals Silenced; Points Disabled; Control Active; Abort; Pre-Discharge; Discharge.

Keypad Switch Controls: Acknowledge/Scroll Display; Signal Silence; Drill; System Reset; Lamp Test.

LCD Display: 80 characters (2 x 40) with long-life LED backlight.

Product Line Information

- “Configuration Guidelines” on page 3
- “Networking Options” on page 4
- “Auxiliary Power Supplies and Batteries” on page 4
- “Audio Options” on page 4
- “Compatible Devices, EIA-232 Ports” on page 4
- “Compatible Devices, EIA-485 Ports” on page 4
- “Compatible Intelligent Devices” on page 4
- “Enclosures, Chassis, and Dress Plates” on page 5
- “Other Options” on page 5



Reviewed for Code Compliance
Permitting and Inspections Department
Approved with Conditions

05/13/2020

CONFIGURATION GUIDELINES

The NFS-320 system ships assembled; description and some options follow. See “Enclosures, Chassis, and Dress Plates” on page 5 for information about mounting peripherals.

NOTE: Stand-alone and network systems require a main display. On stand-alone systems, the panel’s keypad provides the required display. On network systems (two or more networked fire panel nodes), at least one NCA-2, NCS, or ONYXWorks annunciation device is required. (For NCA-2, see DN-7047.)

NFS-320: The standard, factory-assembled NFS-320 system includes the following components: one control panel mounted on chassis (120 V operation — ships with grounding cable, battery interconnect cables, and document kit); includes integral power supply mounted to the main circuit board; one primary display KDM-R2 keypad/display; and one cabinet for surface or semi-flush mounting. *Purchase batteries separately. One or two option boards may be mounted inside the NFS-320 cabinet; additional option boards can be used in remote cabinets. (Non-English versions also available. NFS-320-SP, NFS-320-PO.)*

NFS-320R: Same as NFS-320, but in red enclosure.

NFS-320C: Based on NFS-320 above. NFS-320C supports installation of an optional ACM-series annunciator in the same cabinet. UL- and ULC-listed. (*Non-English version also available: NFS-320C-FR.*) For NFS-320C, see DN-60085.

NFS-320CR: Same as NFS-320C but in a red enclosure. For NFS-320C, see DN-60085.

NFS-320E: Same as NFS-320, but with 240 V operation. (*Non-English versions also available. NFS-320E-SP, NFS-320E-PO.*)

TR-320: Trim ring for the NFS-320 cabinet.

NETWORKING OPTIONS

NCM-W, NCM-F: Standard Network Communications Modules. Wire and multi-mode fiber versions available. See DN-6861.

HS-NCM-W/MF/SF/WMF/WSF/MFSF: High-speed Network Communications Modules. Wire, single-mode fiber, multi-mode fiber, and media conversion models are available. See DN-60454.

RPT-W, RPT-F, RPT-WF: Standard-network repeater board with wire connection (RPT-W), multi-mode fiber connection (RPT-F), or allowing a change in media type between wire and fiber (RPT-WF). Not used with high-speed networks. See DN-6971.

ONYXWorks: UL-listed graphics PC workstation, software, and computer hardware. See DN-7048 for specific part numbers.

NFN-GW-EM-3: NFN Gateway, embedded. See DN-60499.

NWS-3: NOTI•FIRE•NET™ Web Server. See DN-6928.

CAP-GW: Common Alerting Protocol Gateway. See DN-60756.

VESDA-HLI-GW: VESDAnet high-level interface gateway. See DN-60753.

LEDSIGN-GW: UL-listed sign gateway. Interfaces with classic and high-speed NOTI•FIRE•NET networks through the NFN Gateway. See DN-60679.

OAX2-24V: UL-listed LED sign, used with LEDSIGN-GW. See DN-60679.

AUXILIARY POWER SUPPLIES AND BATTERIES

ACPS-610: 6.0 A or 10.0 A addressable charging power supply. See DN-60244.

APS2-6R: Auxiliary Power Supply. Provides up to 6.0 amperes of power for peripheral devices. Includes battery input and transfer relay, and overcurrent protection. Mounts on two of four positions on a CHS-4L or CHS-4 chassis. See DN-5952.

FCPS-24S6/S8: Remote 6 A and 8 A power supplies with battery charger. See DN-6927.

BAT Series: Batteries. NFS-320 uses two 12 volt, 18 to 200 AH batteries. See DN-6933.

AUDIO OPTIONS

NFC-50/100: 25 watt, 25 VRMS, emergency Voice Evacuation Control Panel (VECP) with integral commercial microphone, digital message generator, and Class A or Class B speaker circuits. See DN-60772.

COMPATIBLE DEVICES, EIA-232 PORTS

PRN-7: 80-column printer. See DN-60897.

VS4095/5: Printer, 40-column, 24 V. Mounted in external backbox. See DN-3260.

DPI-232: Direct Panel Interface, specialized modem for extending serial data links to remotely located FACPs and/or peripherals; mount on NFS-320 chassis. See DN-6870.

COMPATIBLE DEVICES, EIA-485 PORTS

ACM-24AT: ONYX Series ACS annunciator – up to 96 points of annunciation with Alarm or Active LED, Trouble LED, and switch per circuit. Active/Alarm LEDs can be programmed (by powered-up switch selection) by point to be red, green, or yellow; the Trouble LED is always yellow. See DN-6862.

AEM-24AT: Same LED and switch capabilities as ACM-24AT, expands the ACM-24AT to 48, 72, or 96 points. See DN-6862.

ACM-48A: ONYX Series ACS annunciator – up to 96 points of annunciation with Alarm or Active LED per circuit. Active/Alarm LEDs can be programmed (by powered-up switch selection) in groups of 24 to be red, green, or yellow. Expandable to 96 points with one AEM-48A. See DN-6862.

AEM-48A: Same LED capabilities as ACM-48A, expands the ACM-48A to 96 points. See DN-6862.

ACM-8R: Remote Relay Module with eight Form-C contacts. Can be located up to 6,000 ft. (1828.8 m) from panel on four wires. See DN-3558.

FDU-80: Terminal mode. 80-character, backlit LCD display. Mounts up to 6,000 ft. (1828.8 m) from panel. Up to 32 per FACP. See DN-6820.

LCD2-80: Terminal and ACS mode. 80-character, backlit LCD display. Mounts up to 6,000 ft. (1828.8 m) from panel. Up to 32 per FACP. See DN-60548.

LDM: Lamp Driver Modules LDM-32, LDM-E32, and LDM-R32; remote custom driver modules. See DN-0551.

SCS: Smoke control stations SCS-8, SCE-8, with lamp drivers SCS-8L, SCE-8L; eight (expandable to 16) circuits (HVAC only). See DN-4818.

TM-4: Transmitter Module. Includes three reverse-polarity circuits and one municipal box circuit; mount on NFS-320 chassis or remotely. See DN-6860.

UDACT-2: Universal Digital Alarm Communicator Transmitter, 636 channel. See DN-60686.

UZC-256: Programmable Universal Zone Coder provides positive non-interfering successive zone coding. Microprocessor-controlled, field-programmable from IBM®-compatible PCs (requires optional programming kit). Mounts in **BB-UZC**. See DN-3404.

COMPATIBLE INTELLIGENT DEVICES

NOTE: “A” suffix indicates ULC-Listed model:

FWSG Wireless SWIFT Gateway: Addressable gateway supports wireless SLC devices. Not appropriate for ULC applications. See DN-60820.

FSA-5000: Intelligent FFAST® XS Fire Alarm Aspiration Sensing Technology. Intelligent aspirating smoke detector for applications up to 5,000 sq.ft. For Canadian applications, order FSA-5000A.

FSA-8000: Intelligent FFAST® XM Fire Alarm Aspiration Sensing Technology. Intelligent aspirating smoke detector for applications up to 8,000 sq.ft. For Canadian applications, order FSA-8000A. See DN-60792

FSA-20000: Intelligent FFAST® XT Fire Alarm Aspiration Sensing Technology. Intelligent aspirating smoke detector for applications up to 28,800 sq.ft. For Canadian applications, order FSA-20000A. See DN-60849.

FSA-20000P FFAST® XT PRO Intelligent Aspiration Detector For applications up to 28,800 sq. ft. (2601 sq. m.) through one to four addressable pipes. See DN-60792

FSB-200(A): Intelligent beam smoke detector. See DN-6985.

FSB-200S(A): Intelligent beam smoke detector with integral sensitivity test. See DN-6985

FSC-851(A): FlashScan IntelliQuad Advanced Multi-Criteria Detector. See DN-60412.

FCO-851(A): FlashScan IntelliQuad PLUS Advanced Multi-Criteria Fire/CO Detector. See DN-60689.

FSI-851(A): Low-profile FlashScan ionization detector. See DN-6934.

FSP-851(A): Low-profile FlashScan photoelectric detector. See DN-6935.

FSP-851T(A): Low-profile FlashScan photoelectric detector with 135°F (57°C) thermal. See DN-6935.

FSP-851R(A): Remote-test capable photoelectric detector for use with DNR(W) duct detector housings. See DN-6935.

FST-851(A): FlashScan thermal detector 135°F (57°C). See DN-6936.



FST-851R(A): FlashScan thermal detector 135°F (57°C) with rate-of-rise. See DN-6936.

FST-851H(A): FlashScan 190°F (88°C) high-temperature thermal detector. See DN-6936.

FAPT-851(A): FlashScan Acclimate Plus low-profile multi-sensor detector. See DN-6937.

FSL-751(A): FlashScan VIEW laser photo detector. See DN-6886.

DNR(A): InnovairFlex low-flow non-relay duct-detector housing (order FSP-851R separately). Replaces FSD-751PL/FSD-751RPL. See DN-60429.

DNRW(A): Same as above with NEMA-4 rating, watertight. See DN-60429.

B224RB: Low-profile relay base. See DN-60054.

B224BI: Isolator base for low-profile detectors. See DN-60054.

B210LP: Low-profile base. Standard U.S. style. Replaces B710LP. See DN-60054.

B501(A): European-style, 4" (10.16 cm) base. See DN-60054.

B200S: Intelligent programmable sounder base, capable of producing a variety of tone patterns including ANSI Temporal 3. Compatible with synchronization protocol. See DN-60054.

B200S-LF: Low-frequency version of B200S. See DN-60054.

B200SR: Sounder base, Temporal 3 or Continuous tone. See DN-60054.

B200SR-LF: Low-frequency version of B200SR. See DN-60054.

FMM-1: FlashScan monitor module. See DN-6720.

FDM-1(A): FlashScan dual monitor module. See DN-6720.

FZM-1(A): FlashScan two-wire detector monitor module. See DN-6720.

FMM-101(A): FlashScan miniature monitor module. See DN-6720.

FCM-1(A): FlashScan control module. See DN-6724.

FCM-1-REL(A): FlashScan releasing control module. See DN-60390.

FRM-1(A): FlashScan relay module. See DN-6724.

FDRM-1(A): FlashScan dual monitor/dual relay module. See DN-60709.

NBG-12LX: Manual pull station, addressable. See DN-6726.

ISO-X: Isolator module. See DN-2243.

ISO-6: Six Fault isolator module. For Canadian applications order ISO-6A. See DN-60844.

XP6-C(A): FlashScan six-circuit supervised control module. See DN-6924.

XP6-MA(A): FlashScan six-zone interface module; connects intelligent alarm system to two-wire conventional detection zone. See DN-6925.

XP6-R(A): FlashScan six-relay (Form-C) control module. See DN-6926.

XP10-M(A): FlashScan ten-input monitor module. See DN-6923.

SLC-IM: SLC integration module, for VESDAnet detectors. See DN-60755.

ENCLOSURES, CHASSIS, AND DRESS PLATES

CAB-BM Marine System: Protects equipment in shipboard and waterfront applications. Also order **BB-MB** for systems using 100 AH batteries. For a full list of required and optional equipment, see DN-60688.

BB-UZC: Backbox for housing the UZC-256. Required for NFS-320 applications. Black. For red, order BB-UZC-R.

NFS-LBB: Battery Box (required for batteries larger than 26 AH).

NFS-LBBR: Same as above, but red.

SEISKIT-320/B26: Seismic mounting kit. Required for seismic-certified applications with NFS-320 and BB-26. Includes battery bracket for two 26 AH batteries.

SEISKIT-BB25: Seismic mounting kit for the BB-25. Includes battery bracket for two 26 AH batteries.

SEISKIT-LBB: Seismic kit for the NFS-LBB. Includes battery bracket for two 55 AH batteries.

OTHER OPTIONS

411: Slave Digital Alarm Communicator. See DN-6619.

411UDAC: Digital Alarm Communicator. See DN-6746.

IPDACT-2/2UD, IPDACT Internet Monitoring Module: Connects to primary and secondary DACT telephone output ports for internet communications over customer-provided Ethernet connection. Requires compatible Teldat VisorALARM Central Station Receiver. Can use DHCP or static IP. See DN-60408.

IPSPLT: Y-adapter option allow connection of both panel dialer outputs to one IPDACT-2/2UD cable input.

IPENC: External enclosure for IPDACT, includes IPBRKT mounting bracket; Red. For Black order **IPENC-B**.

IPGSM-4G: Internet and Digital Cellular Fire Alarm Communicator. Provides selectable configurable paths: cellular only, IP only, or IP primary with cellular backup. Connects to the primary and secondary ports of a DACT. See DN-60769.

BACKBOXES

NOTE: "C" suffix indicates ULC-Listed model:

ABF-1B Annunciator Flush Box.

ABF-1DB(C) Annunciator Flush Box with Door.

ABF-2B Annunciator Flush Box

ABF-2DB(C) Annunciator Flush Box with Door

ABF-4B Annunciator Flush Box

ABS-1TB(C) Annunciator Surface Box

ABS-1B(C) Annunciator Surface Box

ABS-2B Annunciator Surface Box

ABS-2D(C) Annunciator Surface Box

ABS-4D(C) Annunciator Surface Box

NFS-320-RB: Replacement board with central processing unit (CPU). *NOTE: Keypad must be removed before shipping old unit out for repair.*

- NFS-320-RBE: Replacement CPU, Export.
- NFS-320-RB-PO: Replacement CPU, Portuguese.
- NFS-320-RB-POE: Replacement CPU, Export, Portuguese.
- NFS-320-RBC-FR: Replacement CPU, Canadian French.
- NFS-320-RB-SP: Replacement CPU, Spanish.
- NFS-320-RB-SPE: Replacement CPU, Export, Spanish.

NOTE: For other options including compatibility with retrofit equipment, refer to the panel's installation manual, the SLC manual, and the Device Compatibility Document.



Reviewed for Code Compliance
Permitting and Inspections Department
Approved with Conditions

05/13/2020

System Specifications

SYSTEM CAPACITY

- Intelligent Signaling Line Circuits 1
- Intelligent detectors 159
- Addressable monitor/control modules 159
- Programmable internal hardware and output circuits 4
- Programmable software zones 99
- Special programming zones 14
- LCD annunciators per NFS-320/-320E 32
- ACS annunciators per NFS-320/-320E 32 addresses x 64 points

SPECIFICATIONS

- Primary input power
 - NFS-320: 120 VAC, 50/60 Hz, 5.0 A.
 - NFS-320E: 220/240 VAC, 50/60 Hz, 2.5 A.
- Current draw (standby/alarm):
 - NFS-320(E) board: 0.250 A. Add 0.035 A for each NAC in use.
 - KDM-R2 (Backlight on): 0.100 A.
 - Total output 24 V power: 6.0 A in alarm.

NOTE: The power supply has a total of 6.0 A of available power. This is shared by all internal circuits. See Installation Manual for a complete current draw calculation sheet.

- Standard notification circuits (4): 1.5 A each.
- Resettable regulated 24V power: 1.25 A.
- Two non-resettable regulated 24V power outputs:
 - 1.25 A.
 - 0.50 A.
- Non-resettable 5V power: 0.15 A.
- Battery charger range: 18 AH – 200 AH. Use separate cabinet for batteries over 26 AH.
- Float rate: 27.6 V.

CABINET SPECIFICATIONS

NFS-320 cabinet dimensions:

- Backbox: 18.12 in. (46.025 cm) width; 18.12 in. (46.025 cm) height; 5.81 in. (14.76 cm) depth.
- Door: 18.187 in. (46.195 cm) width; 18.40 in. (46.736 cm) height; 0.75 in. (1.905 cm) depth.
- Trim ring: Molding width is 0.905 in. (2.299 cm).
- Shipping weight (without batteries): 36.15 lb. (16.4 kg).

TEMPERATURE AND HUMIDITY RANGES

This system meets NFPA requirements for operation at 0 – 49°C/ 32 – 120°F and at a relative humidity 93% ± 2% RH (noncondensing) at 32°C ± 2°C (90°F ± 3°F). However, the useful life of the system's standby batteries and the electronic components may be adversely affected by extreme temperature ranges and humidity. Therefore, it is recommended that this system and its peripherals be installed in an environment with a normal room temperature of 15 – 27°C/60 – 80°F.

AGENCY LISTINGS AND APPROVALS

The listings and approvals below apply to the basic NFS-320 control panel. In some cases, certain modules may not be listed by certain approval agencies, or listing may be in process. Consult factory for latest listing status.

- **UL/ULC Listed:** S635.
- **FM Approved.**

- **CSFM:** 7165-0028:0243.
- **MEA:** 128-07-E.
- **Fire Dept. of New York:** COA# 6212.
- **City of Chicago.**
- **ULC Listed:** S527-11

NOTE: For additional information on UL- and ULC-listed model NFS-320C, see DN-60085. For information on NFS-320SYS, see DN-60637.

Marine Applications: Marine approved systems must be configured using components itemized in this document. (See Main System Components, in "Product Line Information.") Specific connections and requirements for those components are described in the installation document, PN 54756. When these requirements are followed, systems are approved by the following agencies:

- **US Coast Guard** 161.002/50/0, 161.002/55/0 (Standard 46 CFR and 161.002).
- **Lloyd's Register** 11/600013 (ENV 3 category).
- **American Bureau of Shipping** (ABS) Type Approval.

NOTE: For information on marine applications, see DN-60688.

STANDARDS

The NFS-320 complies with the following UL Standards and NFPA 72, International Building Code (IBC), and California Building Code (CBC) Fire Alarm Systems requirements:

- **UL 864** (Fire).
- **UL 1076** (Burglary).
- **UL 2572** (Mass Notification Systems). (NFS-320 version 20 or higher).
- **ULC-S527-11** Standard for the Installation of Fire Alarm Systems.
- **LOCAL** (Automatic, Manual, Waterflow and Sprinkler Supervisory).
- **AUXILIARY** (Automatic, Manual and Waterflow) (requires TM-4).
- **REMOTE STATION** (Automatic, Manual, Waterflow and Sprinkler Supervisory) (requires TM-4).
- **PROPRIETARY** (Automatic, Manual, Waterflow and Sprinkler Supervisory). *Not applicable for FM.*
- **CENTRAL STATION** (Automatic, Manual, Waterflow and Sprinkler Supervisory) (requires DACT).
- **EMERGENCY VOICE/ALARM.**
- **OT, PSDN** (Other Technologies, Packet-switched Data Network).
- **IBC 2012, IBC 2009, IBC 2006, IBC 2003, IBC 2000** (Seismic).
- **CBC 2007** (Seismic).



Reviewed for Code Compliance
Permitting and Inspections Department
Approved with Conditions

05/13/2020

IntelliQuad™, NOTI-FIRE-NET™, ONYXWorks™, and SWIFT™ are trademarks; and Acclimate® Plus™, FirstCommand®, FlashScan®, Intelligent FFAST®, NOTIFIER®, ONYX®, VeriFire®, and VIEW® are registered trademarks of Honeywell International Inc. Microsoft® and Windows® are registered trademarks of Microsoft Corporation. IBM® is a registered trademark of IBM Corporation.

©2017 by Honeywell International Inc. All rights reserved. Unauthorized use of this document is strictly prohibited.



This document is not intended to be used for installation purposes.
We try to keep our product information up-to-date and accurate.
We cannot cover all specific applications or anticipate all requirements.
All specifications are subject to change without notice.



Country of Origin: USA

For more information, contact Notifier. Phone: (203) 484-7161, FAX: (203) 484-7118.
www.notifier.com

UDACT-2

Universal Digital Alarm Communicator Transmitter



Annunciator Control System

General

The Universal Digital Alarm Communicator Transmitter (UDACT-2) is designed for use on Notifier Fire Alarm Control Panels and on the NCA-2 Network Control Annunciator. When used in conjunction with the NCA-2 network control annunciator, the UDACT-2 can report the status of all control panels on NOTI•FIRE•NET™. The UDACT-2 transmits system status to UL listed Central Station Receivers via the public switched telephone network. The UDACT-2 can be installed in the panel cabinet or remotely in a separate enclosure.

NOTE: The UDACT-2 can also be used with legacy panels. Please refer to the UDACT-2 manual for more information.

The UDACT-2 upload/download programming and firmware updates are accomplished with VeriFire Tools. Refer to the Programming Section for further details.

The UDACT-2 is capable of transmitting the status of software zones (Alarm and Trouble), System Trouble, Panel Off-Normal, Supervisory, Bell Trouble, Low Battery, and AC Fail. The UDACT-2 is capable of transmitting all of the zone and point status associated with each panel.

When the UDACT-2 is used with the NFS-3030, NFS2-3030, and NCA-2 it is capable of reporting up to 2,040 points. Reporting may be in the form of points or zones (refer to the UDACT-2 manual for specific reporting parameters). Points transmitted may be programmed for a variety of types, including fire, water-flow, supervisory, etc.

NOTE: Descriptions regarding point capacity, listed above, are for receivers which receive in Ademco Contact ID format. See chart on page 2 for compatible receivers.

Features

- Programmable with VeriFire Tools version 6.60 or higher, allowing the UDACT-2 programming to be uploaded/downloaded and saved.
- Maximum of 14 point trouble messages transmitted per hour.
- Dual phone lines with line voltage detect.
- Compact in size: 6.75" x 4.25" (17.145 x 10.795 cm).
- USB port for upload/download programming.
- Manual Test Report function.
- Manual Transmission Clear function.
- Mounts in a separate enclosure (ABS-8RB or UBS-1B/R).
- Communicates vital system status including:
 - Independent zone fire alarm.
 - Independent zone non-fire alarm.
 - Independent zone trouble.
 - Independent zone supervisory.
 - AC (mains) Power Loss (programmable).
 - Low Battery and Earth Fault.
 - System Off-Normal.
 - 12 or 24 hour test signal.
 - Abnormal Test Signal per new UL requirements.
 - EIA-485 Communication Bus Failure.
- Annunciation of UDACT-2 Troubles including: loss of phone lines, communication failure with either Central Station, total communications failure.
- Individual LEDs for: Power, EIA-485 Loss, Manual Test, Kissoff, Comm Fail, Primary Line Seize, Secondary Line Seize and Modem Communications.

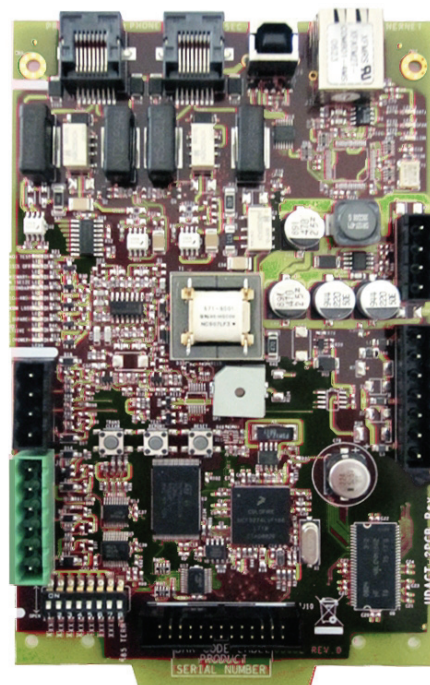

UDACT-2

- Open Collector relay driver for Total Communications Failure or UDACT-2 trouble.
- Real-time clock.
- Extensive transient protection.
- EIA-485 interface to host panel.

Programming

The UDACT-2 programming is created and downloaded using VeriFire Tools. This enables the unit to be programmed prior to installation, be easily modified, and saved either online or offline. A printed report with point or zone information can be generated from VeriFire Tools for an ONYX Series panel or network annunciator. The point report consists of the central station point address, ACS point, ACS point function, panel label, panel point, type code, custom and extended label, alarm verification, walktest participation, presignal, and PAS information. The zone report consists of a grid with the central station point address, ACS point address, source, ACS point function, custom label and panel label. This report may be sent to the Central Station for their records. VeriFire Tools also supports upgrading the UDACT-2 operating firmware.



Reviewed for Code Compliance
Permitting and Inspections Department
Approved with Conditions

05/13/2020

Communication Formats

- Ademco Contact ID
- 4+2 Standard
- SIA

NOTE: Ademco Contact ID must be used for independent zone reporting.

Type Mode Feature

Ademco Contact ID format - only Use Type Mode to identify reports to Central Station as:

- Fire Alarm
- Supervisory
- Pull Station
- Heat Detector
- Waterflow
- Duct Detector
- Flame Sensor
- Smoke Zone
- Burglary
- 24 hour Non-Burglary
- High Temperature
- Low Temperature
- Low Water Pressure
- Low Water Level
- Pump Failure

Electrical Specifications

Standby current: 40 mA.

Current while communicating: 75 mA.

Maximum current while communicating and with open collector output activated: 100 mA.

Voltage: Regulated 24 volts. Range: 21.2 to 28.2 volts.

Agency Listings and Approvals

In some cases, certain modules may not be listed by certain approval agencies, or listing may be in process. Consult factory for latest listing status.

- UL/ULC Listed: S635
- FM Approved
- CSFM: 7165-0028:0243 (NFS2-640/320), 7165-0028:0224 (NFS2-3030)
- FDNY: COA#6085, COA#6098

Ordering Information

UDACT-2: Universal Digital Alarm Communicator Transmitter. Includes operating and programming instructions, and mounting hardware.

MCBL-7: DACT phone cord, 7 ft (2.13 m) long (two required).

ABS-8RB: Metal enclosure for externally mounting UDACT-2 up to 6,000 ft./1828.8 m from host FACP. 9.94" H x 4.63" W x 2.50" D (cm: 25.248 H x 11.760 W x 6.350 D).

UBS-1B: Metal enclosure with solid door, Black.

UBS-1BR: Metal enclosure with solid door, Red.

R-10E: SPDT Form-C relay. Contacts rated for 10 A @ 115 VAC. Connects to open collector relay driver.

R-20E: DPDT Two Form-C relays. Contacts rated for 10A @ 115 VAC. Connects to open collector relay driver.

FBD-1: Ferrite bead kit. Use for remote mounting only.

UL Listed Receivers

The chart below shows UL listed receivers compatible with the UDACT-2. A check in the protocol column indicates the receiver supports that protocol.

Receiver	4+2 Standard 1800/2300	Ademco Contact ID	SIA
Ademco 685 (1)	✓	✓	
Ademco MX8000 (2)	✓	✓	✓
Silent Knight 9500 (3)	✓	✓	✓
Silent Knight 9800 (4)	✓	✓	✓
FBI CP220FB (5)	✓	✓	✓
Osborne Hoffman 2000E (6)		✓	✓
Radionics 6600 (7)		✓	✓
SurGard MLR2 (8)	✓	✓	
SurGard System III (9)		✓	✓
SurGard MLR-2000 (10)		✓	

(1) With 685-8 Line Card with Rev 4.4d software

(2) With 124060V206B and 124063 Line Card Rev B

(3) With version V2.4 Receiver & 126047 Line Card Rev G

(4) With 124077V2.00 Receiver & 126047 Line Card Rev M

(5) With software V3.9

(6) With V.7301 Receiver S/W

(7) With 01.01.03 Receiver S/W & Line Card 01.01.03

(8) With software V1.86

(9) With software V1.72

(10) With DSP4016 and V1.6 Line Card



Reviewed for Code Compliance
Permitting and Inspections Department
Approved with Conditions

05/13/2020

NOTIFIRENET™ is a trademark and Notifier® is a registered trademark of Honeywell International Inc.
©2012 by Honeywell International Inc. All rights reserved. Unauthorized use of this document is strictly prohibited.



This document is not intended to be used for installation purposes.
We try to keep our product information up-to-date and accurate.
We cannot cover all specific applications or anticipate all requirements.
All specifications are subject to change without notice.



Made in the U.S.A.

For more information, contact Notifier. Phone: (203) 484-7161, FAX: (203) 484-7118.
www.notifier.com

Specifications

Nominal Voltage	12V	
Nominal Capacity (20HR)	26AH	
Dimension	Length	167mm (6.56 inches)
	Width	177mm (6.97 inches)
	Height	125mm (4.92 inches)
	Total Height (with Terminal)	125mm (4.92 inches)
	Approximate Weight	8.0 kg (17.64 lbs)
Battery Type	Valve Regulated Lead-Acid Battery, AGM Design	
Terminal Type	T2 / NB	
Rated Capacity	26.6AH	(20hr, 1.75V/cell, 25°C/77°F)
	2.46AH	(10hr, 1.75V/cell, 25°C/77°F)
	22.2AH	(5hr, 1.75V/cell, 25°C/77°F)
	21.1AH	(3hr, 1.60V/cell, 25°C/77°F)
	16.4AH	(1hr, 1.60V/cell, 25°C/77°F)
Max. Discharge Current	390A	
Internal Resistance	14mΩ	
Operating Temp. Range	Discharge:	-20°C (-4°F)~50°C (122°F)
	Charge:	-20°C (-4°F)~50°C (122°F)
	Storage:	-20°C (-4°F)~40°C (104°F)
Nominal Operating Temp. Range	25±3°C (77±5°F)	
Container Material	ABS (Option: 94-HB & 94-V0 flame retardant case)	
Capacity affected by Temperature	40°C (104°F)	103%
	25°C (77°F)	100%
	0°C (32°F)	86%
Self Discharge	SigmasTek SP series batteries may be stored for up to 6 months at 25°C (77°F) and then a freshening charge is recommended. For higher temperatures the time interval will be shorter.	



Applications

- Uninterruptible Power Supply (UPS)
- Electric wheelchairs, scooters, bikes
- Electronic apparatus and equipment
- Alarm and security systems
- Emergency first responder equipment
- Emergency lighting
- Medical devices
- Electric carts
- Telecom equipment
- Switchgear
- Solar power systems

MH47929



Reviewed for Code Compliance
Permitting and Inspections Department
Approved with Conditions

05/13/2020

Constant Current Discharge (Amperes Per Battery) at 25°C (77°F)

F.V. (V/cell) \ Discharge Time	5min	10min	15min	30min	1h	2h	3h	5h	8h	10h	20h
1.60V	100.6	64.9	49.6	29.1	16.4	9.60	7.02	4.64	3.10	2.55	1.36
1.65V	94.50	61.9	47.7	28.3	16.1	9.43	6.92	4.58	3.07	2.52	1.35
1.70V	87.60	58.4	45.5	27.4	15.6	9.23	6.79	4.52	3.03	2.50	1.34
1.75V	79.50	54.5	43.1	26.3	15.1	9.00	6.65	4.44	2.99	2.46	1.33
1.80V	70.30	50.1	40.3	25.0	14.5	8.74	6.48	4.35	2.94	2.43	1.30
1.85V	59.30	44.8	37.0	23.5	13.9	8.41	6.27	4.24	2.87	2.38	1.28

Constant Power Discharge (Watts Per Cell) at 25°C (77°F)

F.V. (V/cell) \ Discharge Time	5min	10min	15min	30min	1h	2h	3h	5h	8h	10h	20h
1.60V	182.3	119.8	92.9	56.0	32.0	18.8	13.8	9.18	6.17	5.08	2.73
1.65V	172.9	115.1	89.9	54.6	31.4	18.5	13.7	9.10	6.13	5.05	2.71
1.70V	161.6	109.4	86.3	53.0	30.5	18.2	13.4	8.99	6.07	5.00	2.69
1.75V	148.1	102.9	82.2	51.0	29.6	17.8	13.2	8.87	6.00	4.96	2.67
1.80V	132.1	95.2	77.3	48.8	28.7	17.3	12.9	8.71	5.92	4.89	2.63
1.85V	112.3	85.7	71.4	46.1	27.5	16.7	12.5	8.52	5.81	4.81	2.61

Dimensions

T2 Terminal

Unit: mm (inches)

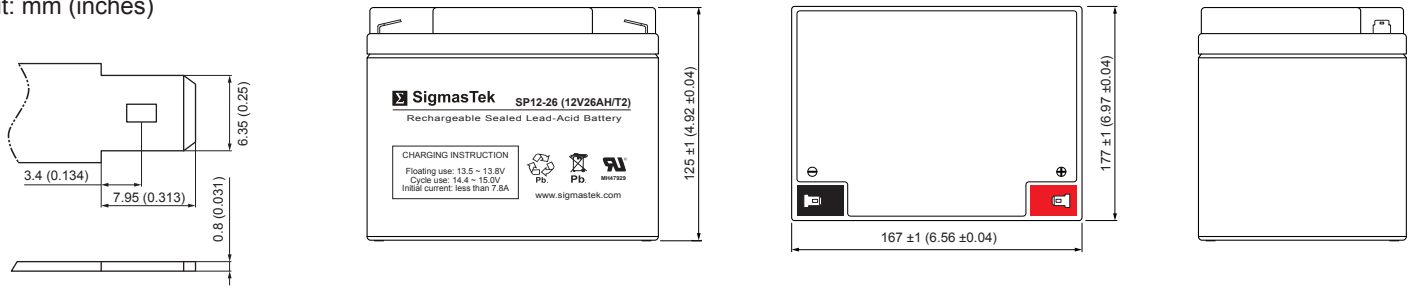

Cycle Service Life

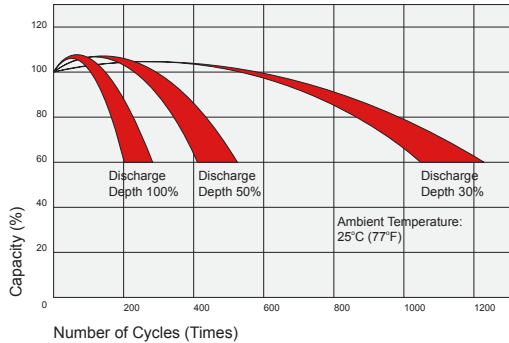

Self Discharge Characteristics



Reviewed for Code Compliance
Permitting and Inspections
Department
05/13/2020

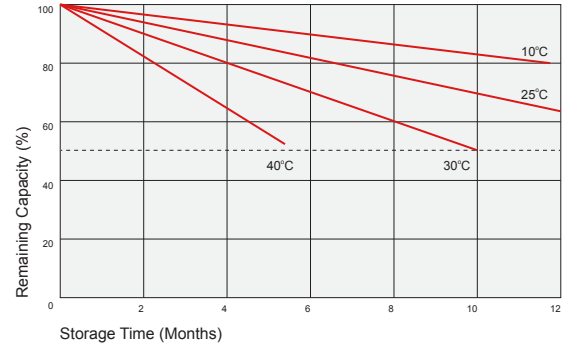

Discharge Characteristics

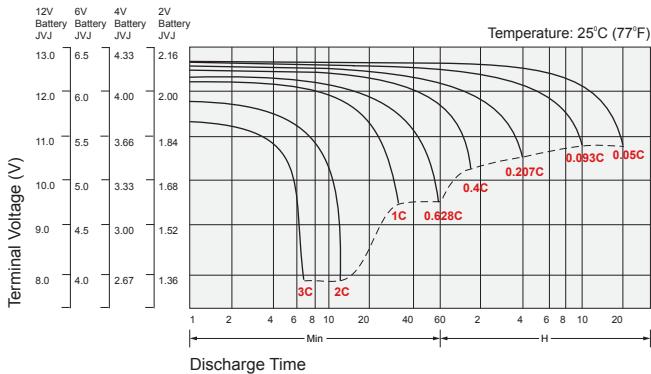

Float Charging Characteristics

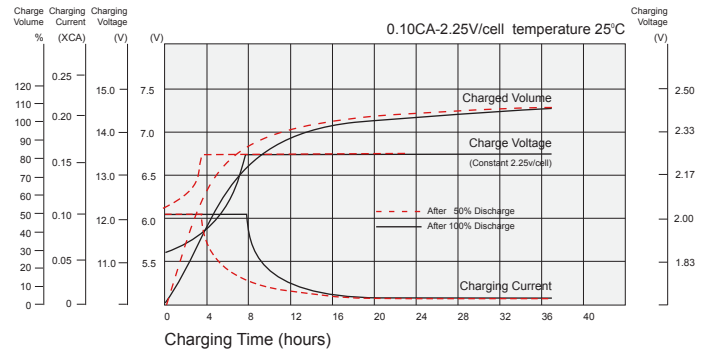

Temperature Effects in Relation to Battery Capacity

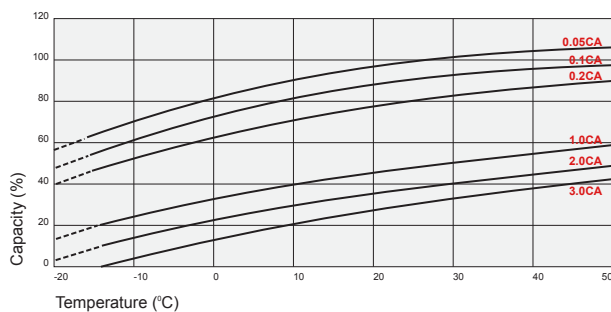

Temperature Effects on Long Term Float Life

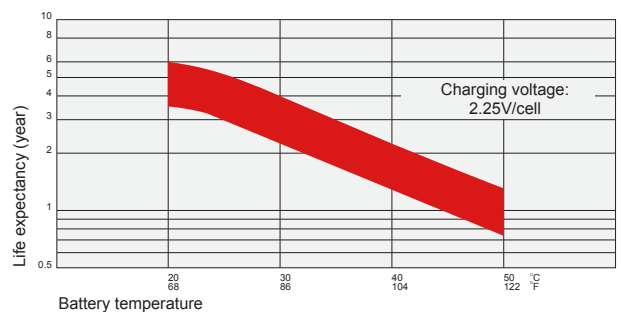

Contact Information

SigmatTek
7651 W 100th Place
Bridgeview, IL 60455, USA

T: (888) 988-8290
www.sigmastek.com
order@sigmastek.com

FDU-80

80 Character Liquid Crystal Display



Annunciators

General

The FDU-80 is a compact, cost-effective, 80-character, backlit LCD remote Fire Annunciator for use with the NOTIFIER Fire-Warden-100-2, NFS2-640, and NFS-320 Fire Alarm Control Panels (FACPs). The FDU-80 mimics the display of the control panel and displays complete system point status information.

Up to 32 FDU-80s may be connected onto the EIA-485 terminal port of each FACP. The FDU-80 requires no programming, which saves time during system commissioning.

Features

- 80-character Liquid Crystal Display.
- Mimics all display information from the host panel.
- Control switches for System Acknowledge, Signal Silence, Drill and Reset with enable key.
- System status LEDs for Power, Alarm, Trouble, Supervisory and Alarm Silenced.
- No programming necessary — FDU-80 connects to the terminal port on the FACP.
- Displays device type identifiers, individual point alarm, trouble or supervisory, zone and custom alpha labels.
- Time-and-date display field.
- Aesthetically pleasing design.
- May be powered from the host FACP or by remote power supply (requires 24 VDC).
- Up to 32 FDU-80 annunciators per FACP.
- Plug-in terminal blocks for ease of installation and service.
- Can be remotely located up to 6,000 feet (1828.8 m) from the FACP.
- Local piezo sounder with alarm and trouble resound.
- Semi-flush mounts to 2.188" (5.556 cm) minimum deep, three-gang electrical box (NOTIFIER PN 10103) or three-gangable electrical switchbox.
- Surface-mounts to NOTIFIER PN SBB-3 surface backbox.

Operation

The FDU-80 annunciator provides the FACP with point annunciation with full display text on an 80-character LCD display. The FDU-80 also provides an array of LEDs to indicate system status, and includes control switches for remote control of critical system functions.

The FDU-80 provides the FACP with up to 32 remote serially connected annunciators. All field-wiring terminations on the FDU-80 use removable, compression-type terminal blocks for ease of wiring and circuit testing.

Communication between the FACP and the annunciators is accomplished over an EIA-485 serial interface, which greatly reduces wire and installation cost over traditional systems.

Installation

The FDU-80 can be semi-flush mounted to a 2.188" (5.556 cm) minimum deep, three-gang electrical box or three-gangable electrical switchboxes. Alternately, an SBB-3 surface backbox is available for surface-mount applications.

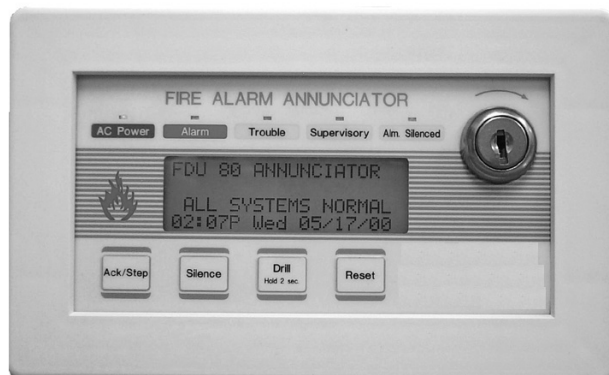

6820fdub.jpg

Ordering Information

FDU-80: 80 character, backlit, LCD Fire Annunciator with control switches for remote control of system functions, and key-switch lock.

FDU-80C: ULC-listed version; see DN-60573 for details.

10103: Three-gang electrical box, minimum 2.188" (5.556 cm) deep, for semi-flush mount applications.

SBB-3: Three-gang surface backbox for surface-mount applications.

Agency Listings And Approvals

These listings and approvals apply to the modules specified in this document. In some cases, certain modules or applications may not be listed by certain approval agencies, or listing may be in process. Consult factory for latest listing status.

- **UL Listed:** S635
- **MEA Listed:** 245-00-E
- **FDNY:** COA#6038
- **CSFM:** 7120-0028:209
- **FM Approved**

NOTE: For ULC-listed version, see DN-60573.



Reviewed for Code Compliance
Permitting and Inspections Department
Approved with Conditions

05/13/2020



Reviewed for Code Compliance
Permitting and Inspections Department
Approved with Conditions

05/13/2020

NOTIFIER® is a registered trademark of Honeywell International Inc.
©2010 by Honeywell International Inc. All rights reserved. Unauthorized use
of this document is strictly prohibited.



This document is not intended to be used for installation purposes.
We try to keep our product information up-to-date and accurate.
We cannot cover all specific applications or anticipate all requirements.
All specifications are subject to change without notice.



For more information, contact Notifier. Phone: (203) 484-7161, FAX: (203) 484-7118.
www.notifier.com

NBG-12LX

Addressable Manual Pull Station



Intelligent/Addressable Devices

General

The Notifier NBG-12LX is a state-of-the-art, dual-action (i.e., requires two motions to activate the station) pull station that includes an addressable interface for any Notifier intelligent control panel except FireWarden series panels, and the NSP-25 panel. Because the NBG-12LX is addressable, the control panel can display the exact location of the activated manual station. This leads fire personnel quickly to the location of the alarm.

Features

- Maintenance personnel can open station for inspection and address setting without causing an alarm condition.
- Built-in bicolor LED, which is visible through the handle of the station, flashes in normal operation and latches steady red when in alarm.
- Handle latches in down position and the word “ACTIVATED” appears to clearly indicate the station has been operated.
- Captive screw terminals wire-ready for easy connection to SLC loop (accepts up to 12 AWG/3.25 mm² wire).
- Can be surface mounted (with SB-10 or SB-I/O) or semi-flush mounted. Semi-flush mount to a standard single-gang, double-gang, or 4" (10.16 cm) square electrical box.
- Smooth dual-action design.
- Meets ADAAG controls and operating mechanisms guidelines (Section 4.1.3[13]); meets ADA requirement for 5 lb. maximum activation force.
- Highly visible.
- Attractive shape and textured finish.
- Key reset.
- Includes Braille text on station handle.
- Optional trim ring (BG12TR).
- Meets UL 38, Standard for Manually Actuated Signaling Boxes.
- Up to 99 NBG-12LX stations per loop on CLIP protocol loops.
- Up to 159 NBG-12LX stations per loop on FlashScan® protocol loops.
- Dual-color LED blinks green to indicate normal on FlashScan® systems.

Construction

Shell, door, and handle are molded of durable polycarbonate material with a textured finish.

Specifications

- **Shipping Weight:** 9.6 oz. (272.15 g)
- **Normal operating voltage:** 24 VDC.
- **Maximum SLC loop voltage:** 28.0 VDC.
- **Maximum SLC standby current:** 375 µA.
- **Maximum SLC alarm current:** 5 mA.
- **Temperature Range:** 32°F to 120°F (0°C to 49°C)
- **Relative Humidity:** 10% to 93% (noncondensing)
- **For use indoors in a dry location**



The NBG-12LX
Addressable Manual Pull Station



Reviewed for Code Compliance
Permitting and Inspections Department
Approved with Conditions

05/13/2020

Installation

The NBG-12LX will mount semi-flush into a single-gang, double-gang, or standard 4" (10.16 cm) square electrical outlet box, or will surface mount to the model SB-10 or SB-I/O surface backbox. If the NBG-12LX is being semi-flush mounted, then the optional trim ring (BG12TR) may be used. The BG12TR is usually needed for semi-flush mounting with 4" (10.16 cm) or double-gang boxes (not with single-gang boxes).

Operation

Pushing in, then pulling down on the handle causes it to latch in the down/activated position. Once latched, the word “ACTIVATED” (in bright yellow) appears at the top of the handle, while a portion of the handle protrudes from the bottom of the station. To reset the station, simply unlock the station with the key and pull the door open. This action resets the handle; closing the door automatically resets the switch.

Each manual station, on command from the control panel, sends data to the panel representing the state of the manual switch. Two rotary decimal switches allow address settings (1 – 159 on FlashScan® systems, 1 – 99 on CLIP systems).

Architectural/Engineering Specifications

Manual Fire Alarm Stations shall be non-coded, with a key-operated reset lock in order that they may be tested, and so designed that after actual Emergency Operation, they cannot be restored to normal except by use of a key. An operated station shall automatically condition itself so as to be visually detected as activated. Manual stations shall be constructed of red-colored polycarbonate material with clearly visible operating instructions provided on the cover. The word FIRE shall appear on the front of the stations in white letters, 1.00 inches (2.54 cm) or larger. Stations shall be suitable for surface mounting on matching backbox SB-10 or SB-I/O; or semi-flush mounting on a standard single-gang, double-gang, or



4" (10.16 cm) square electrical box, and shall be installed within the limits defined by the Americans with Disabilities Act (ADA) or per national/local requirements. Manual Stations shall be Underwriters Laboratories listed.

Manual stations shall connect with two wires to one of the control panel SLC loops. The manual station shall, on command from the control panel, send data to the panel representing the state of the manual switch. Manual stations shall provide address setting by use of rotary decimal switches.

The loop poll LED shall be clearly visible through the front of the station. The LED shall flash while in the normal condition, and stay steadily illuminated when in alarm.

Product Line Information

NBG-12LX: Dual-action addressable pull station. Includes key locking feature. (Listed for Canadian and non-Canadian applications.)

NBG-12LXSP: Spanish/English labelled version.

NBG-12LXP: Portuguese labelled version.

SB-10: Surface backbox; metal.

SB-I/O: Surface backbox; plastic.

BG12TR: Optional trim ring.

17021: Keys, set of two.

NY-Plate: New York City trim plate.

Agency Listings and Approvals

In some cases, certain modules or applications may not be listed by certain approval agencies, or listing may be in process. Consult factory for latest listing status.

- **UL/ULC Listed:** S692 (listed for Canadian and non-Canadian applications).
- **MEA:** 67-02-E.
- **CSFM:** 7150-0028:0199.
- **FDNY:** COA #6085 (NFS2-640), COA #6098 (NFS2-3030).
- **BSMI:** CI313066760047.
- **U.S. Coast Guard.**
- **Lloyd's Register.**
- **FM Approved.**

Patented: U.S. Patent No. D428,351; 6,380,846; 6,314,772; 6,632,108.

NOTIFIER® and FlashScan® are registered trademarks of Honeywell International Inc.

©2012 by Honeywell International Inc. All rights reserved. Unauthorized use of this document is strictly prohibited.



This document is not intended to be used for installation purposes.
We try to keep our product information up-to-date and accurate.
We cannot cover all specific applications or anticipate all requirements.
All specifications are subject to change without notice.



Made in the U.S. A.

For more information, contact Notifier. Phone: (203) 484-7161, FAX: (203) 484-7118.
www.notifier.com

FSP-951 Series

Intelligent Plug-In Photoelectric Smoke Detectors



Intelligent/Addressable Devices

General

The NOTIFIER FSP-951 Series intelligent plug-in smoke detectors are designed for both performance and aesthetics. A new modern, sleek, contemporary design and enhanced optical sensing chamber is engineered to sense smoke produced by a wide range of combustion sources in accordance with more stringent code standards. The FSP-951 Series detector sensitivity can be programmed in the control panel software. Sensitivity is continuously monitored and reported to the panel. Point ID capability allows each detector's address to be set with rotary, decimal address switches, providing exact detector location for selective maintenance when chamber contamination reaches an unacceptable level. Dual electronic thermistors add 135°F (57°C) fixed temperature thermal sensing on the FSP-951T. The FSP-951R is a remote test capable detector for use with DNR Series duct detector housings. FSP-951 series detectors are available for both FlashScan® and CLIP applications as designated.

Features

- New modern profile for improved aesthetics.
- Designed to meet UL268 7th Edition.
- Stable communication technique with noise immunity.
- Low standby current.
- Two-wire SLC connection.
- Compatible with FlashScan® and CLIP protocol systems.
- Rotary, decimal addressing (1-99 on CLIP systems, 1-159 on FlashScan systems).
- Optional remote, single-gang LED accessory.
- Dual LED design provides 360° viewing angle.
- Visible bi-color LEDs blink green every time the detector is addressed, and illuminate steady red on alarm (*FlashScan systems only*).
- Remote test feature from the panel.
- Walk test with address display (an address on 121 will blink the detector LED: 12-[pause]-1 (*FlashScan systems only*)).
- Built-in functional test switch activated by external magnet.
- Built-in tamper-resistant feature.
- Sealed against back pressure.
- Expanded color options.
- SEMS screws for wiring of the separate base.
- Optional relay, isolator, and sounder bases.

Specifications

Sensitivity:

- UL Applications: 0.5% to 4.0% per foot obscuration.
- ULC Applications: 0.5% to 3.5% per foot obscuration.

Size: 2.0" (5.3 cm) high; base determines diameter.

- B300-6: 6.1" (15.6 cm) diameter.
- B501: 4" (10.2 cm) diameter.

For a complete list of detector bases see DN-60981.

Shipping weight: 3.4oz (96.4g)

Operating Temperature range:

- FSP-951, 0°C to 50°C (32°F to 122°F).
- FSP-951T, 0°C to 38°C (32°F to 100°F).



FSP-951 in B300-6 Base



Reviewed for Code Compliance
Permitting and Inspections Department
Approved with Conditions

05/13/2020

- FSP-951R installed in a DNR/DNRW, -20°C to 70°C (-4°F to 158°F).

UL/ULC Listed Velocity Range: 0-4000 ft/min. (1219.2 m/min.), suitable for installation in ducts.

Relative Humidity: 10%-93% noncondensing.

Thermal Ratings: Fixed-temperature setpoint 135°F (57°C).

DETECTOR SPACING AND APPLICATIONS

NOTIFIER recommends spacing detectors in compliance with NFPA 72. In low airflow applications with smooth ceiling, space detectors 30 feet (9.1m). For specific information regarding detector spacing, placement, and special applications refer to NFPA 72. *System Smoke Detector Application Guide*, document A05-1003, is available at systemsensor.com

ELECTRICAL SPECIFICATIONS

Voltage Range: 15-32 volts DC peak.

Standby Current (max. avg.): 200µA @ 24VDC (one communication every five seconds with LED enabled).

LED Current (max.): 4.5mA @ 24 VDC ("ON").

Installation

FSP-951 series plug-in detectors use a separate base to simplify installation, service, and maintenance.

Mount base (all base types) on an electrical backbox which is at least 1.5" (3.81 cm) deep. For a chart of compatible junction boxes, see DN-60981.

NOTE: 1) Because of inherent supervision provided by the SLC loop, end-of-line resistors are not required. Wiring "T-taps" or branches are permitted for Style 4 (Class "B") wiring. 2) When using relay or sounder bases, consult the ISO-X(A) installation sheet I56-1380 for device limitations between isolator modules and isolator bases.

Agency Listings and Approvals

These listings and approvals apply to the detectors specified in this document. In some cases, certain detectors or applications may not be listed by certain approval agencies, or listing may be in process. Consult factory for latest listing status.

- UL/ULC Listed: S911
- FM Approved
- CSFM: 7272-0028:0503

Product Line Information

NOTE:

- Detectors must be mounted to one of the Intelligent Bases listed below.
- "A" suffix indicates ULC Listed model.
- "IV" suffix indicates FlashScan® and CLIP device.

FSP-951: White, low-profile intelligent photoelectric sensor, FlashScan only.

FSP-951A: Same as FSP-951 but with ULC listing.

FSP-951-IV: Ivory, low-profile intelligent photoelectric sensor.

FSP-951A-IV: Same as FSP-951-IV but with ULC listing.

FSP-951T: White, same as FSP-951 but includes a built-in 135°F (57°C) fixed-temperature thermal device. FlashScan only.

FSP-951TA: Same as FSP-951T but with ULC listing.

FSP-951T-IV: Ivory, same as FSP-951T but includes a built-in 135°F (57°C) fixed-temperature thermal device.

FSP-951TA-IV: Same as FSP-951T-IV but with ULC listing.

FSP-951R: White, low-profile intelligent photoelectric sensor, remote test capable. For use with DNR/DNRW. FlashScan only.

FSP-951RA: Same as FSP-951R but with ULC listing. For use with DNRA.

FSP-951R-IV: Ivory, low-profile intelligent photoelectric sensor, remote test capable. For use with DNR/DNRW.

FSP-951RA-IV: Same as FSP-951R-IV but with ULC listing. For use with DNRA.

INTELLIGENT BASES

NOTE: For details on intelligent bases, see DN-60981

B300-6: White, 6" base, standard flanged low-profile mounting base.

B300-6-IV: Ivory, 6" base, standard flanged low-profile mounting base.

B300A-6: Same as B300-6, ULC listed.

B300A-6-IV: Ivory, 6" standard flanged low-profile mounting base, ULC listed.

B300-6-BP: Bulk pack of B300-6, package contains 10

B501-WHITE: White, 4" standard European flangeless mounting base. UL/ULC listed.

B501-BL: Black, 4" standard European flangeless mounting base. UL/ULC listed.

B501-IV: Ivory color, 4" standard European flangeless mounting base. UL/ULC listed.

B501-WHITE-BP: Bulk pack of B501-WHITE contains 10.

B224RB-WH: White, relay base.

B224RB-IV: Ivory, relay base.

B224RBA-WH: White, relay base, ULC listing.

B224RBA-IV: Ivory, relay base, ULC listing.

B224BI-WH: White, *isolator* detector base.

B224BI-IV: Ivory *isolator* detector base.

B224BIA-WH: White, *isolator* detector base, ULC listing.

B224BIA-IV: Ivory *isolator* detector base, ULC listing.

B200S-WH: White, Intelligent addressable sounder base capable of producing sound output in high or low volume with ANSI Temporal 3, ANSI Temporal 4, continuous tone, marching tone, and custom tone. Uses FlashScan protocol.

B200S-IV: Ivory, Intelligent addressable sounder base capable of producing sound output in high or low volume with ANSI Temporal 3, ANSI Temporal 4, continuous tone, marching tone, and custom tone. Uses FlashScan protocol.

B200SA-WH: Same as B200S-WH, ULC listing.

B200SA-IV: Same as B200S-IV, ULC listing.

B200SCOA-WH: White, Intelligent, programmable sounder base in English/French (required in Canada for ULC applications with SO Series detector applications).

B200SCOA-IV: Ivory Intelligent, programmable sounder base in English/French (required in Canada for ULC applications with SO Series detector applications, ULC listing).

B200S-LF-WH: White, Low Frequency Intelligent, programmable sounder base. Produces a fundamental frequency of 520 Hz +/- 10% with a square wave or its equivalent; designed to meet the NFPA 72 sleeping space requirement.

B200S-LF-IV: Ivory, Low Frequency Intelligent, programmable sounder base. Produces a fundamental frequency of 520 Hz +/- 10% with a square wave or its equivalent; designed to meet the NFPA 72 sleeping space requirement.

B200SR-WH: White, Intelligent sounder base capable of producing sound output with ANSI Temporal 3 or continuous tone. Intended for retrofit applications.

B200SR-IV: Ivory, Intelligent sounder base capable of producing sound output with ANSI Temporal 3 or continuous tone. Intended for retrofit applications.

B200SRA-WH: Same as B200SR-WH with, ULC listing.

B200SRA-IV: Same as B200SR-IV in Ivory color, ULC listing.

B200SR-LF-WH: White, Low Frequency Intelligent, programmable sounder base. Produces a fundamental frequency of 520 Hz +/- 10% with a square wave or its equivalent; designed to meet the NFPA 72 sleeping space requirement. Intended for retrofit applications.

B200SR-LF-IV: Ivory, Low Frequency Intelligent, programmable sounder base. Produces a fundamental frequency of 520 Hz +/- 10% with a square wave or its equivalent; designed to meet the NFPA 72 sleeping space requirement. Intended for retrofit applications.

MOUNTING KITS AND ACCESSORIES

TR300: White, replacement flange for B210LP(A) base.

TR300-IV: Ivory, replacement flange for B210LP(A) base.

RA100Z(A): Remote LED annunciator. 3 – 32 VDC. Mounts to a U.S. single-gang electrical box. For use with B501(A) and B300(A)-6.

M02-04-00: Test magnet.

M02-09-00: Test magnet with telescoping handle.



Reviewed for Code Compliance
Permitting and Inspections Department
Approved with Conditions

05/13/2020



Reviewed for Code Compliance
Permitting and Inspections Department
Approved with Conditions

05/13/2020

©2018 by Honeywell International Inc. All rights reserved. Unauthorized use of this document is strictly prohibited.



This document is not intended to be used for installation purposes.
We try to keep our product information up-to-date and accurate.
We cannot cover all specific applications or anticipate all requirements.
All specifications are subject to change without notice.

For more information, contact Notifier. Phone: (800) 627-3473, FAX: (203) 484-7118.
www.notifier.com

FST-951 Series

Intelligent Thermal (Heat) Detectors



Intelligent / Addressable Devices

General

The NOTIFIER FST-951 Series intelligent thermal detectors are designed for both performance and aesthetics. A new modern, sleek, contemporary design and advanced thermal technologies make the FST-951 Series ideal for both system operation and building design. The point ID address, set using rotary decimal switches, provide specific detector locations. The series includes a 135°F/57°C fixed-temperature, rate-of-rise and a 180°F/88°C fixed high-temperature detectors. These thermal detectors provide effective, intelligent property protection in a variety of applications. Detectors are available for both FlashScan® and CLIP applications as designated.

Features

- Sleek and stylish contemporary design.
- Advanced thermal technology for fast response.
- Fixed temperature model (FST-951) factory preset to 135°F (57°C).
- Rate-of-rise model (FST-951R), 15°F (8.3°C) per minute.
- High temperature model (FST-951H) factory preset to 190°F (88°C).
- Addressable by device.
- Compatible with FlashScan® and CLIP protocol systems.
- Rotary, decimal addressing (1-99 on CLIP systems, 1-159 on FlashScan systems).
- Two-wire SLC connection.
- Visible LEDs “blink” every time the unit is addressed.
- 360°-field viewing angle of the visual alarm indicators (two bi-color LEDs). LEDs blink green in Normal condition and turn on steady red in Alarm.
- Integral communications and built-in device-type identification.
- Remote test feature from the panel.
- Built-in functional test switch activated by external magnet.
- Walk test with address display (an address of 121 will blink the detector LED 12-(pause)-1).
- Low standby current.
- Built-in tamper-resistant feature.
- Designed for direct-surface or electrical-box mounting.
- Sealed against back pressure.
- Plugs into separate base for ease of installation and maintenance.
- SEMS screws for wiring of the separate base.
- Optional remote, single-gang LED accessory.
- Optional sounder, relay, and isolator bases.

Specifications

- Size:** 2.0" (5.3 cm) high; base determines diameter.
- B300-6: 6.1" (15.6 cm) diameter.
 - B501: 4" (10.2 cm) diameter.

For a complete list of detector bases, see DN-60981

Shipping weight: 3.4oz (96.4g)

Operating temperature range:

- FST-951, FST-951R Series: –20°C to 38°C (–4°F to 100°F);
- FST-951H Series: –20°C to 66°C (–4°F to 150°F).



FST-951R in B300-6 Base



Reviewed for Code Compliance
Permitting and Inspections Department
Approved with Conditions

05/13/2020

Detector spacing: UL approved for 50 ft. (15.24 m) center to center. FM approved for 25 x 25 ft. (7.62 x 7.62 m) spacing.

Relative humidity: 10% – 93% non-condensing.

Thermal ratings: Fixed-temperature set point 57°C (135°F), rate-of-rise detection 8.3°C (15°F) per minute, high temperature heat 88°C (190°F).

ELECTRICAL SPECIFICATIONS

Voltage range: 15 - 32 volts DC peak.

Standby current (max. avg.): 200uA @ 24 VDC (one communication every 5 seconds with LED enabled).

LED current (max.): 4.5mA @ 24 VDC (“ON”).

Applications

Use thermal detectors for protection of property. For further information, refer to I56-6522, Applications Manual for System Smoke Detectors, which provides detailed information on detector spacing, placement, zoning, wiring, and special applications.

Installation

The FST-951 Series plug-in intelligent thermal detectors use a separate base to simplify installation, service, and maintenance. Installation instructions are shipped with each detector.

Mount base (all base types) on an electrical backbox which is at least 1.5" (3.81 cm) deep. For a chart of compatible junction boxes, see DN-60054.

NOTE: 1) Because of the inherent supervision provided by the SLC loop, end-of-line resistors are not required. Wiring “T-taps” or branches are permitted for Style 4 (Class “B”) wiring. **2)** When using relay or sounder bases, consult the ISO-X(A) installation sheet I56-1380 for device limitations between isolator modules and isolator bases.

Agency Listings and Approvals

These listings and approvals apply to the detectors specified in this document. In some cases, certain detectors or applications may not be listed by certain approval agencies, or listing may be in process. Consult factory for latest listing status.

- UL/ULC Listing: S2101
- FM Approved
- CSFM: 7270-0028:0502

Product Line Information

NOTE: "A" suffix indicates ULC Listed model.

NOTE: "-IV" suffix indicates FlashScan® and CLIP device.

FST-951: White, low-profile intelligent 135°F fixed thermal sensor, FlashScan only.

FST-951A: Same as FST-951 but with ULC listing.

FST-951-IV: Ivory, low-profile intelligent 135°F fixed thermal sensor, FlashScan and CLIP.

FST-951A-IV: Same as FST-951-IV but with ULC listing.

FST-951R: White, low-profile intelligent rate-of-rise thermal sensor, FlashScan only.

FST-951RA: Same as FST-951R but with ULC listing.

FST-951R-IV: Ivory, low-profile intelligent rate-of-rise fixed thermal sensor, FlashScan and CLIP.

FST-951RA-IV: Same as FST-951R-IV but with ULC listing.

FST-951H: White, low-profile intelligent 190°F fixed thermal sensor, FlashScan only.

FST-951HA: Same as FST-951H but with ULC listing.

FST-951H-IV: Ivory, low-profile intelligent 190°F thermal sensor, FlashScan and CLIP.

FST-951HA-IV: Same as FST-951H-IV but with ULC listing.

INTELLIGENT BASES

NOTE: For details on intelligent bases, see DN-60981

B300-6: White, 6" base, standard flanged low-profile mounting base.

B300-6-IV: Ivory, 6" base, standard flanged low-profile mounting base.

B300A-6: Same as B300-6, ULC listed.

B300A-6-IV: Ivory, 6" standard flanged low-profile mounting base, ULC listed.

B300-6-BP: Bulk pack of B300-6, package contains 10

B501-WHITE: White, 4" standard European flangeless mounting base. UL/ULC listed.

B501-BL: Black, 4" standard European flangeless mounting base. UL/ULC listed.

B501-IV: Ivory color, 4" standard European flangeless mounting base. UL/ULC listed.

B501-WHITE-BP: Bulk pack of B501-WHITE contains 10.

B224RB-WH: White, relay base.

B224RB-IV: Ivory, relay base.

B224RBA-WH: White, relay base, ULC listing.

B224RBA-IV: Ivory, relay base, ULC listing.

B224BI-WH: White, *isolator* detector base.

B224BI-IV: Ivory *isolator* detector base.

B224BIA-WH: White, *isolator* detector base, ULC listing.

B224BIA-IV: Ivory *isolator* detector base, ULC listing.

B200S-WH: White, Intelligent addressable sounder base capable of producing sound output in high or low volume with ANSI Temporal 3, ANSI Temporal 4, continuous tone, marching tone, and custom tone. Uses FlashScan protocol.

B200S-IV: Ivory, Intelligent addressable sounder base capable of producing sound output in high or low volume with ANSI Temporal 3, ANSI Temporal 4, continuous tone, marching tone, and custom tone. Uses FlashScan protocol.

B200SA-WH: Same as B200S-WH, ULC listing.

B200SA-IV: Same as B200S-IV, ULC listing.

B200SCOA-WH: White, Intelligent, programmable sounder base in English/French (required in Canada for ULC applications with SO Series detector applications).

B200SCOA-IV: Ivory Intelligent, programmable sounder base in English/French (required in Canada for ULC applications with SO Series detector applications, ULC listing).

B200S-LF-WH: White, Low Frequency Intelligent, programmable sounder base. Produces a fundamental frequency of 520 Hz +/- 10% with a square wave or its equivalent; designed to meet the NFPA 72 sleeping space requirement.

B200S-LF-IV: Ivory, Low Frequency Intelligent, programmable sounder base. Produces a fundamental frequency of 520 Hz +/- 10% with a square wave or its equivalent; designed to meet the NFPA 72 sleeping space requirement.

B200SR-WH: White, Intelligent sounder base capable of producing sound output with ANSI Temporal 3 or continuous tone. Intended for retrofit applications.

B200SR-IV: Ivory, Intelligent sounder base capable of producing sound output with ANSI Temporal 3 or continuous tone. Intended for retrofit applications.

B200SRA-WH: Same as B200SR-WH with, ULC listing.

B200SRA-IV: Same as B200SR-IV in Ivory color, ULC listing.

B200SR-LF-WH: White, Low Frequency Intelligent, programmable sounder base. Produces a fundamental frequency of 520 Hz +/- 10% with a square wave or its equivalent; designed to meet the NFPA 72 sleeping space requirement. Intended for retrofit applications.

B200SR-LF-IV: Ivory, Low Frequency Intelligent, programmable sounder base. Produces a fundamental frequency of 520 Hz +/- 10% with a square wave or its equivalent; designed to meet the NFPA 72 sleeping space requirement. Intended for retrofit applications.

MOUNTING KITS AND ACCESSORIES

TR300: White, replacement flange for B210LP(A) base.

TR300-IV: Ivory, replacement flange for B210LP(A) base.

RA100Z(A): Remote LED annunciator. 3 – 32 VDC. Mounts to a U.S. single-gang electrical box. For use with B501(A) and B3006(A)-6.

M02-04-00: Test magnet.

M02-09-00: Test magnet with telescoping handle.



Reviewed for Code Compliance
Permitting and Inspections Department
Approved with Conditions

05/13/2020



Reviewed for Code Compliance
Permitting and Inspections Department
Approved with Conditions

05/13/2020

Notifier® and FlashScan® are registered trademarks of Honeywell International Inc.
Notifier® and Bayblend® is a registered trademark of Bayer Corp.
©2018 by Honeywell International Inc. All rights reserved. Unauthorized use of this document is strictly prohibited.



This document is not intended to be used for installation purposes.
We try to keep our product information up-to-date and accurate.
We cannot cover all specific applications or anticipate all requirements.
All specifications are subject to change without notice.

For more information, contact Notifier. Phone: (800) 627-3473, FAX: (203) 484-7118.
www.notifier.com

FCO-951 Series Advanced Multi-Criteria Fire/CO Detector

General Description

The IntelliQuad® PLUS FCO-951/-IV and FCO-951A/-IV advanced multi-criteria fire/CO detector is a plug-in, addressable device that provides both fire and carbon monoxide (CO) detection. The detector combines four separate sensing elements in one unit to sense multiple components of a fire: smoke, CO, light/flare, and heat. This approach enables enhanced sensitivity to real fire with heightened immunity to nuisance particulates. For CO, the detector's electrochemical sensing cell creates a separate signal for life safety CO detection.

Multiple sensors and communication can greatly reduce nuisance alarms compared to single sensing methods. Sophisticated algorithms maximize the advantages of the sensor types creating our best detection strategy offering heightened immunity to nuisance particulate and enhanced sensitivity to real fire.

- Photoelectric sensors detect airborne particles associated with smoke.
- Thermal sensors detect heat and rate-of-rise (135°F fixed temperature threshold).
- Carbon Monoxide sensors detect this by-product of fire for accurate fire detection.
- Infrared sensors discern light patterns in the environment as an additional data point for alarm determination.

This ability to reject certain nuisance alarm triggers, such as theater smoke, supports the use of the IntelliQuad PLUS Series detector in applications where moderate to heavy nuisance conditions exist that might cause single sensing detectors to false alarm.

The IntelliQuad PLUS Series detector meets both UL 268 7th edition and UL 521 listing requirements for fire detection as well as the UL 2075 standard for system-connected life safety carbon monoxide detection. Canadian models meet listing requirements of CAN/ULC S529, CAN/ULC S530 and CSA 6.19-01.

Released through the incomplete burning of various fuels, CO is a colorless, odorless and deadly gas that is virtually impossible to detect with the human senses. Because the potential exists for dangerous levels of CO to accumulate in almost any building, legislation mandating the use of CO detection in commercial spaces continues to grow.

B200S series intelligent sounder bases (B200SCOA series in Canada) are recommended for use with FCO-951 Series IntelliQuad PLUS. These bases can generate either a Temp 3 pattern for fire or a Temp 4 pattern for CO alarm indication. The B200S/B200SCOA series bases recognize the System Sensor synchronization protocol, for use as a component of the general evacuation signal — along with other System Sensor horns, horn strobes, and chimes — when connected to a power supply or Fire Alarm Control Panel (FACP) output capable of generating the System Sensor synchronization pulses.

Features

- Unique ability to detect all four major elements of a fire
- Separate CO detection signal
- Highest nuisance alarm immunity
- Automatic drift compensation for smoke and CO sensors
- Uses only one address on the SLC
- RealTest® CO testing capability
- UL 268 7th edition, UL 521, and UL 2075 listed; CAN/ULC S529, CAN/ULC S530 and CSA 6.19-01 listed



Reviewed for Code Compliance
Permitting and Inspections Department
Approved with Conditions

05/13/2020

FCO-951 Multi-Criteria Fire/CO Detector
installed in B200S-WH sounder base

- Separate audible signal for fire or CO alarm when used with a B200S series base (B200SCOA series in Canada)
- 10-year CO cell with end-of-life warning
- New modern profile
- Expanded color options

Specifications

PHYSICAL

- Height: 2.7" (69 mm) installed in B200S series sounder base
- Diameter: 6.875" (175 mm) installed in B200S series sounder base
- Weight: 3.4 oz. (95 g)
- Color: White (-IV models are ivory)
- Operating Humidity Range: 15% to 90% Relative Humidity, Non-condensing
- Operating Temperature Range: 32°F to 100°F (0°C to 38°C)
- Air Velocity: 0 to 4000 ft./min. (0 to 1219.2 m/min.)

ELECTRICAL SPECIFICATIONS

- Operating Voltage Range: 15 to 32 VDC
- Operating Current @ 24 VDC: 200 uA (one communication every 5 seconds with green LED blink on communication)
- Maximum Alarm Current: 2 mA @ 24 VDC (one communication every 5 seconds with red LED solid on)
- Maximum Current: 4.5 mA @ 24 VDC (one communication every 5 seconds with amber LED solid on)
- Isolator Load Rating: 0.0063

CO MONITORING UL STANDARD REFERENCE

Alarm thresholds are as follows:

Parts Per Million	Detector Response Time
70 ± 5ppm	60 – 240 min.
150 ± 5ppm	10 – 50 min.
400 ± 10ppm	4 – 15 min.

Standards

Per UL standard 2075, the FCO-951 Series has been tested to the sensitivity limits defined in UL Standard 2034.

UL Standard: UL 268 7th Edition

ULC Standard: CAN/ULC S529

Agency Listings and Approvals

The listings and approvals below apply to the FCO-951 Series. In some cases, certain modules may not be listed by certain approval agencies, or listing may be in process. Consult the factory for the latest listing status.

UL/ULC: S1111

CSFM: 7272-0028:0510

Ordering Information

FCO-951: Advanced multi-criteria fire/CO detector, FlashScan, white, UL listed. For ivory, order FCO-951-IV.

FCO-951A: Advanced multi-criteria fire/CO detector, FlashScan, white, ULC listed. For ivory, order FCO-951A-IV.

BASES

Note: Canadian CO applications require base B200SCOA-W/-IV.

B501-WHITE: 4" Mounting base, white

B501-WHITE-BP: 4" mounting base, white, 10-pack

B501-IV: 4" Mounting base, ivory

B501-BL: 4" Mounting base, black

B300-6: 6" Flanged mounting base, white

B300-6-BP: 6" Flanged mounting base, white, 10-pack

B300-6-IV: 6" Flanged mounting base, ivory

B200S-WH: Intelligent addressable sounder base, white

B200S-IV: Intelligent addressable sounder base, ivory

B200SCOA-WH: Intelligent addressable sounder base for Canadian CO applications, white, ULC-listed

B200SCOA-IV: Intelligent addressable sounder base for Canadian CO applications, ivory, ULC-listed

B200S-LF-WH: Intelligent addressable sounder base, low-frequency, white, UL-listed

B200S-LF-IV: Intelligent addressable sounder base, low-frequency, ivory, UL-listed

B224BI-WH: Isolator base, white

B224BI-IV: Isolator base, ivory

B224RB-WH: Relay base, white

B224RB-IV: Relay base, ivory

ACCESSORIES

SMB600: Surface mounting kit (flanged)

TR300: Trim ring, white

TR300-IV: Trim ring, ivory

CK300-IR: IR color kit (includes cover and trim ring), white, 10-pack

CK300-IR-IV: IR color kit (includes cover and trim ring), ivory, 10-pack

CK300-IR-BL: IR color kit (includes cover and trim ring), black, 10-pack. *Note: Not for use in Canadian CO applications*

RA100Z(A): Remote LED annunciator

M02-04-00: Detector test magnet

M02-09-00: Telescoping test magnet

ACCESSORIES



RA100Z(A)
Remote LED Annunciator



CK300-IR-BL
Color Kit



TR300
Trim Ring



This document is not intended to be used for installation purposes.

We try to keep our product information up-to-date and accurate.

We cannot cover all specific applications or anticipate all requirements.

All specifications are subject to change without notice.

FlashScan®, NOTIFIER®, IntelliQuad®, and RealTest® are registered trademarks of Honeywell International Inc.

©2019 by Honeywell International Inc. All rights reserved. Unauthorized use of this document is strictly prohibited.

Country of Origin: Mexico

NOTIFIER

12 Clintonville Road
Northford, CT 06472
203.484.7161
www.notifier.com



Reviewed for Code Compliance
Permitting and Inspections Department
Approved with Conditions

05/13/2020



Intelligent Bases Standard, Relay, Isolator, Sounder, and Low-Frequency Sounder Bases

General

Intelligent FlashScan® and CLIP detector mounting bases are available to install NOTIFIER detectors in any application. Bases are available for the new, modern looking aesthetically pleasing 900 series addressable detectors, as well as previous series detectors. Both flanged and flangeless bases are available.

To meet code and specific application requirements **Relay, Isolator and Sounder Bases** versions are available. Relay bases provide one form-C contact for auxiliary functions such as door closure and elevator recall. Isolator bases allow loops to continue to operate under fault conditions and automatically restore when the fault is removed. Sounder bases are available in temporal and non-temporal pattern versions depending on whether the signal is to be used for evacuation purposes. Low frequency sounder bases are UL listed for low frequency operation and comply with NFPA 72 requirements for sleeping spaces.

Specifications

NOTE: Specifications applies to all model variants "A", "-BL", "-LF", "-IV". See Product Line Information for detailed model description.

Diameter

- B501: 4" (10.16 cm) diameter.
- B300-6: 6.1" (15.49 cm) diameter.
- B224RI, B224RB, B210LP: 6.2" (15.748 cm) diameter.
- B200S, B200SR, B200SCOA: 6.875" (17.46 cm) diameter.

Wire gauge:

- B224BI, B224RB: 14 to 24 AWG.
- B300-6, B210LP, B501, B200S, B200SR, B200SCOA: 12 to 24 AWG

Temperature range:

- B224BI, B224RB, B200S, B200SR, B200SCOA: 32°F to 120°F (0°C to 49°C).
- B300-6, B210LP, B501: -4°F to 150°F (-20°C to 66°C).

Humidity range: 10% to 93% RH, non-condensing.

System temperature and humidity ranges: This system meets NFPA requirements for operation at 0°C to 49°C (32°F to 120°F); and at a relative humidity (noncondensing) of 85% at 30°C (86°F) per NFPA, and 93% ± 2% at 32°C ± 2°C (89.6°F ± 1.1°F) per ULC. However, the useful life of the system's standby batteries and the electronic components may be adversely affected by extreme temperature ranges and humidity. Therefore, it is recommended that this system and all peripherals be installed in an environment with a nominal room temperature of 15°C to 27°C (60°F to 80°F).

Electrical Ratings

FOR B200 SERIES BASES:

External supply voltage: 16 to 33 VDC (VFWR)

Standby current:

500 µA maximum.

Alarm current:

- B200S(A)(-IV)
 - 35 mA maximum at high-volume setting.
 - 15 mA maximum at low-volume setting.
- B200S-LF(-IV), High-volume setting:



Flangeless Mounting Base
B501(A)



Flanged Mounting Base
B210LP(A)



Sounder Base
B200S(A), B200SR(A),
B200SCOA



Relay Base
B224RB(A)



Low-Frequency
Sounder
Base B200S-LF,
B200SR-LF



Standard Flanged
Low-Profile Base
B300-6

- 70 mA maximum @ 33.0 VDC.
- 90 mA maximum @ 24.0 VDC.
- 140 mA maximum @ 16.0 VDC.
- B200S-LF(-IV), Low-volume setting:
 - 15 mA maximum @ 33.0 VDC.
 - 20 mA maximum @ 24.0 VDC.
 - 25 mA maximum @ 16.0 VDC.
- B200SR(A)(-IV)
 - 35 mA maximum.
- B200SR-LF(-IV)
 - 65 mA maximum @ 33.0 VDC.
 - 90 mA maximum @ 24.0 VDC.
 - 125 mA maximum @ 16.0 VDC.
- B200SCOA(-IV)
 - 40mA Max. (DC)
 - 70mA Max. (FWR)

SLC operating voltage: 15 to 32 VDC.

SLC standby current: See applicable sensor specification.

Sound output:

- B200S(A)(-LF)(-IV), high-volume*: Greater than 85 dBA minimum.
- B200S(A)(-LF)(-IV), low-volume*: Greater than 75 dBA minimum.
- B200SR(A)(-LF)(-IV)*: Greater than 85 dBA minimum.
- B200SCOA(-IV), high-volume**: Greater than 87 dBA minimum.
- B200SCOA(-IV), low-volume**: Greater than 85 dBA minimum



Reviewed for Code Compliance
Permitting and Inspections Department
Approved with Conditions

05/13/2020

*Measured in a UL reverberant room at 10 feet, 24 Volts (continuous tone)
**Measured in a ULC anechoic room at 10 feet, 24 Volts continuous tone)

FOR B224BI, B224RB (A) (-IV):

Operating voltage: 15 to 32 VDC (powered by SLC).

Standby ratings: <500 µA maximum @ 24 VDC.

Set time (B224RB(A)(-IV) only): short delay 55 to 90 msec; long delay 6 to 9 seconds.

Reset time (B224RB(A)(-IV) only): 20 msec maximum.

Relay characteristics (B224RB(A)(-IV) only): two-coil latching relay; one Form-C contact; ratings (UL/CSA): 0.9 A @ 125 VAC, 0.9 A @ 110 VDC, and 3.0 A @ 30 VDC.

Product Line Information

INTELLIGENT BASES

NOTE: "A" suffix indicates ULC Listed model.

NOTE: "-IV" suffix indicates Ivory color model.

NOTE: "-BL" suffix indicates Black color model.

B210LP: Flanged mounted base.

B210LPA: Same as B210LP ULC listed.

B210LPBP: Bulk pack of B210LP contains 10.

B300-6: White, 6" base, standard flanged low-profile mounting base. (CSFM: 7300-1653:0109)

B300A-6: Same as B300-6, ULC listed.

B300-6-BP: Bulk pack of B300-6, package contains 10

B300-6-IV: Ivory, 6" base, standard flanged low-profile mounting base. (CSFM: 7300-1653:0109)

B300A-6-IV: Ivory, 6" standard flanged low-profile mounting base, ULC listed.

B501-WHITE: White, 4" standard European flangeless mounting base. UL/ULC listed. (CSFM: 7300-1653:0109)

B501-WHITE-BP: Bulk pack of B501-WHITE contains 10.

B501-BL: Black, 4" standard European flangeless mounting base. UL/ULC listed. (CSFM: 7300-1653:0109)

B501-IV: Ivory color, 4" standard European flangeless mounting base. UL/ULC listed. (CSFM: 7300-1653:0109)

B224RB-WH: White, relay base. (CSFM: 7300-1653:0216)

B224RB-IV: Ivory, relay base. (CSFM: 7300-1653:0216)

B224RBA-WH: White, relay base, ULC listing.

B224RBA-IV: Ivory, relay base, ULC listing.

B224BI-WH: White, *isolator* detector base. (CSFM: 7300-1653:0216)

B224BI-IV: Ivory *isolator* detector base. (CSFM: 7300-1653:0216)

B224BIA-WH: White, *isolator* detector base, ULC listing.

B224BIA-IV: Ivory *isolator* detector base, ULC listing.

B200S-WH: White, Intelligent addressable sounder base capable of producing sound output in high or low volume with ANSI Temporal 3, ANSI Temporal 4, continuous tone, marching tone, and custom tone. Uses FlashScan protocol. (CSFM: 7300-1653:0213)

B200S-IV: Ivory, Intelligent addressable sounder base capable of producing sound output in high or low volume with ANSI Temporal 3, ANSI Temporal 4, continuous tone, marching tone, and custom tone. Uses FlashScan protocol. (CSFM: 7300-1653:0213)

B200SA-WH: Same as B200S-WH, ULC listing.

B200SA-IV: Same as B200S-IV, ULC listing.

B200SCOA-WH: White, Intelligent, programmable sounder base in English/French (required in Canada for ULC applications with SO Series detector applications).

B200SCOA-IV: Ivory Intelligent, programmable sounder base in English/French (required in Canada for ULC applications with SO Series detector applications, ULC listing).

B200S-LF-WH: White, Low Frequency Intelligent, programmable sounder base. Produces a fundamental frequency of 520 Hz +/- 10% with a square wave or its equivalent; designed to meet the NFPA 72 sleeping space requirement. (CSFM: 7300-1653:0238)

B200S-LF-IV: Ivory, Low Frequency Intelligent, programmable sounder base. Produces a fundamental frequency of 520 Hz +/- 10% with a square wave or its equivalent; designed to meet the NFPA 72 sleeping space requirement. (CSFM: 7300-1653:0238)

B200SR-WH: White, Intelligent sounder base capable of producing sound output with ANSI Temporal 3 or continuous tone. Intended for retrofit applications. (CSFM: 7300-1653:0213)

B200SR-IV: Ivory, Intelligent sounder base capable of producing sound output with ANSI Temporal 3 or continuous tone. Intended for retrofit applications. (CSFM: 7300-1653:0213)

B200SRA-WH: Same as B200SR-WH with, ULC listing.

B200SRA-IV: Same as B200SR-IV in Ivory color, ULC listing.

B200SR-LF-WH: White, Low Frequency Intelligent, programmable sounder base. Produces a fundamental frequency of 520 Hz +/- 10% with a square wave or its equivalent; designed to meet the NFPA 72 sleeping space requirement. Intended for retrofit applications. (CSFM: 7300-1653:0238)

B200SR-LF-IV: Ivory, Low Frequency Intelligent, programmable sounder base. Produces a fundamental frequency of 520 Hz +/- 10% with a square wave or its equivalent; designed to meet the NFPA 72 sleeping space requirement. Intended for retrofit applications. (CSFM: 7300-1653:0238)

MOUNTING KITS AND ACCESSORIES

TR300: White, replacement flange for B210LP(A) base.

TR300-IV: Ivory, replacement flange for B210LP(A) base.

RA100Z(A): Remote LED annunciator. 3 – 32 VDC. Mounts to a U.S. single-gang electrical box. For use with B501(A) and B300(A)-6.

M02-04-00: Test magnet.

M02-09-00: Test magnet with telescoping handle.

XR2B: Detector removal tool. Allows installation and/or removal of detector heads from bases in high ceiling applications.

XP-4: Extension pole for XR2B. Comes in three 5-foot (1.524m) sections.

T55-127-010: Detector removal tool without pole.

CK300: White, detector color kit. Pack of 10.

CK300-IR: White, detector color kit for use with FPTI and FCO Series detectors. Pack of 10.

CK300-IV: Ivory, detector color kit. Pack of 10.

CK300-IR-IV: Ivory, detector color kit for use with FPTI and FCO Series detectors. Pack of 10.

CK300-BL: Black, detector color kit. Pack of 10.

CK300-IR-BL: Black, detector color kit for use with FPTI and FCO Series detectors. Pack of 10.





Agency Listings and Approvals

The listings and approvals below apply to intelligent bases as noted. In some cases, certain modules or applications may not be listed by certain approval agencies, or listing may be in process. Consult factory for latest listing status.

- **UL Listed:** S911, S1115
- **ULC Listed:** S911, S1115.
- **FM Approved.**
- **MEA:** 22-95-E, 205-94-E Vol. 2; 257-06-E
- **CSFM:** 7270-0028-0502, 7272-0028:0503, 7300-1653:0126, 7135-1653:0213, 7300-1653:0109

Junction Box Selection Guide

Base Models	Single Gang	3.5" Oct.	4.0" Oct.	4.0" Sq.	4.0" Sq. with 3.0" mud ring	50 mm	60 mm	70 mm	75 mm
B200S, B200SR, B200SCOA	Yes	Yes	Yes	Yes	Yes	No	No	No	No
B501	No	Yes	No	No	Yes	Yes	Yes	Yes	No
B210LP	Yes	Yes	Yes	Yes	Yes	No	No	No	No
B224RB	No	Yes	Yes	Yes	No	No	Yes	Yes	Yes
B224BI	No	Yes	Yes	Yes	No	No	No	Yes	Yes

NOTE: Box depth contingent on base and wire size.
 Refer to National Electric Code or applicable local codes for appropriate recommendations.

NOTE: Applies to all model variants "A", "-BL", "-LF", "-IV". See Product Line Information for detailed model description.



Reviewed for Code Compliance
Permitting and Inspections Department
Approved with Conditions

05/13/2020



This document is not intended to be used for installation purposes.
We try to keep our product information up-to-date and accurate.
We cannot cover all specific applications or anticipate all requirements.
All specifications are subject to change without notice.

FlashScan®, NOTIFIER® and System Sensor® are registered trademarks of Honeywell International Inc.
©2018 by Honeywell International Inc. All rights reserved.
Unauthorized use of this document is strictly prohibited.

Country of Origin: USA

NOTIFIER
12 Clintonville Road
Northford, CT 06472
203.484.7161
www.notifier.com



FMM-1(A), FMM-101(A), FZM-1(A) & FDM-1(A)

Monitor Modules with FlashScan®



Intelligent/Addressable Devices

General

Four different monitor modules are available for Notifier's intelligent control panels for a variety of applications. Monitor modules supervise a circuit of dry-contact input devices, such as conventional heat detectors and pull stations, or monitor and power a circuit of two-wire smoke detectors (FZM-1(A)).

FMM-1(A) is a standard-sized module (typically mounts to a 4" [10.16 cm] square box) that supervises either a Style D (Class A) or Style B (Class B) circuit of dry-contact input devices.

FMM-101(A) is a miniature monitor module a mere 1.3" (3.302 cm) H x 2.75" (6.985 cm) W x 0.65" (1.651 cm) D that supervises a Style B (Class B) circuit of dry-contact input devices. Its compact design allows the FMM-101(A) to be mounted in a single-gang box behind the device it monitors.

FZM-1(A) is a standard-sized module that monitors and supervises compatible two-wire, 24 volt, smoke detectors on a Style D (Class A) or Style B (Class B) circuit.

FDM-1(A) is a standard-sized dual monitor module that monitors and supervises two independent two-wire Style B (Class B) dry-contact initiating device circuits (IDCs) at two separate, consecutive addresses in intelligent, two-wire systems.

FlashScan® (U.S. Patent 5,539,389) is a communication protocol developed by NOTIFIER that greatly increases the speed of communication between analog intelligent devices. Intelligent devices communicate in a grouped fashion. If one of the devices within the group has new information, the panel CPU stops the group poll and concentrates on single points. The net effect is response speed greater than five times that of other communication protocols.

FMM-1(A) Monitor Module

- Built-in type identification automatically identifies this device as a monitor module to the control panel.
- Powered directly by two-wire SLC loop. No additional power required.
- High noise (EMF/RFI) immunity.
- SEMS screws with clamping plates for ease of wiring.
- Direct-dial entry of address: 01 – 159 on FlashScan loops; 01 – 99 on CLIP loops.
- LED flashes green during normal operation (programmable option) and latches on steady red to indicate alarm.

The FMM-1(A) Monitor Module is intended for use in intelligent, two-wire systems, where the individual address of each module is selected using the built-in rotary switches. It provides either a two-wire or four-wire fault-tolerant Initiating Device Circuit (IDC) for normally-open-contact fire alarm and supervisory devices. The module has a panel-controlled LED indicator. The FMM-1(A) can be used to replace MMX-1(A) modules in existing systems.

FMM-1(A) APPLICATIONS

Use to monitor a zone of four-wire smoke detectors, manual fire alarm pull stations, waterflow devices, or other normally-



FMM-1(A) (Type H)

open dry-contact alarm activation devices. May also be used to monitor normally-open supervisory devices with special supervisory indication at the control panel. Monitored circuit may be wired as an NFPA Style B (Class B) or Style D (Class A) Initiating Device Circuit. A 47K Ohm End-of-Line Resistor (provided) terminates the Style B circuit. No resistor is required for supervision of the Style D circuit.

FMM-1(A) OPERATION

Each FMM-1(A) uses one of the available module addresses on an SLC loop. It responds to regular polls from the control panel and reports its type and the status (open/normal/short) of its Initiating Device Circuit (IDC). A flashing LED indicates that the module is in communication with the control panel. The LED latches steady on alarm (subject to current limitations on the loop).

FMM-1(A) SPECIFICATIONS

Nominal operating voltage: 15 to 32 VDC.

Maximum current draw: 5.0 mA (LED on).

Average operating current: 375 µA (LED flashing), 1 communication every 5 seconds, 47k EOL.

Maximum IDC wiring resistance: 1500 Ohms.

Maximum IDC Voltage: 11 Volts.

EOL resistance: 47K Ohms.

Temperature range: 32°F to 120°F (0°C to 49°C).

Humidity range: 10% to 93% noncondensing.

Dimensions: 4.5" (11.43 cm) high x 4" (10.16 cm) wide x 1.25" (3.175 cm) deep. Mounts to a 4" (10.16 cm) square x 2.125" (5.398 cm) deep box.



Reviewed for Code Compliance
Permitting and Inspections Department
Approved with Conditions

05/13/2020

FMM-101(A) Mini Monitor Module

- Built-in type identification automatically identifies this device as a monitor module to the panel.
- Powered directly by two-wire SLC loop. No additional power required.
- High noise (EMF/RFI) immunity.
- Tinned, stripped leads for ease of wiring.
- Direct-dial entry of address: 01 – 159 on FlashScan loops; 01 – 99 on CLIP loops.

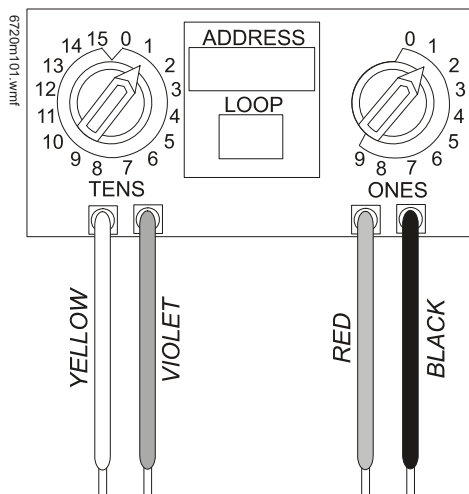

The FMM-101(A) Mini Monitor Module can be installed in a single-gang junction directly behind the monitored unit. Its small size and light weight allow it to be installed without rigid mounting. The FMM-101(A) is intended for use in intelligent, two-wire systems where the individual address of each module is selected using rotary switches. It provides a two-wire initiating device circuit for normally-open-contact fire alarm and security devices. The FMM-101(A) can be used to replace MMX-101(A) modules in existing systems.

FMM-101(A) APPLICATIONS

Use to monitor a single device or a zone of four-wire smoke detectors, manual fire alarm pull stations, waterflow devices, or other normally-open dry-contact devices. May also be used to monitor normally-open supervisory devices with special supervisory indication at the control panel. Monitored circuit/device is wired as an NFPA Style B (Class B) Initiating Device Circuit. A 47K Ohm End-of-Line Resistor (provided) terminates the circuit.

FMM-101(A) OPERATION

Each FMM-101(A) uses one of the available module addresses on an SLC loop. It responds to regular polls from the control panel and reports its type and the status (open/normal/short) of its Initiating Device Circuit (IDC).

FMM-101(A) SPECIFICATIONS

Nominal operating voltage: 15 to 32 VDC.

Average operating current: 350 μ A, 1 communication every 5 seconds, 47k EOL; 600 μ A Max. (Communicating, IDC Shorted).

Maximum IDC wiring resistance: 1500 Ohms.

Maximum IDC Voltage: 11 Volts.

Maximum IDC Current: 450 μ A.

EOL resistance: 47K Ohms.

Temperature range: 32°F to 120°F (0°C to 49°C).

Humidity range: 10% to 93% noncondensing.

Dimensions: 1.3" (3.302 cm) high x 2.75" (6.985 cm) wide x 0.65" (1.651 cm) deep.

Wire length: 6" (15.24 cm) minimum.

FZM-1(A) Interface Module

- Supports compatible two-wire smoke detectors.
- Supervises IDC wiring and connection of external power source.
- High noise (EMF/RFI) immunity.
- SEMS screws with clamping plates for ease of wiring.
- Direct-dial entry of address: 01 – 159 on FlashScan loops, 01 – 99 on CLIP loops.
- LED flashes during normal operation; this is a programmable option.
- LED latches steady to indicate alarm on command from control panel.

The FZM-1(A) Interface Module is intended for use in intelligent, addressable systems, where the individual address of each module is selected using built-in rotary switches. This module allows intelligent panels to interface and monitor two-wire conventional smoke detectors. It transmits the status (normal, open, or alarm) of one full zone of conventional detectors back to the control panel. All two-wire detectors being monitored must be UL compatible with the module. The FZM-1(A) can be used to replace MMX-2(A) modules in existing systems.

FZM-1(A) APPLICATIONS

Use the FZM-1(A) to monitor a zone of two-wire smoke detectors. The monitored circuit may be wired as an NFPA Style B (Class B) or Style D (Class A) Initiating Device Circuit. A 3.9 K Ohm End-of-Line Resistor (provided) terminates the end of the Style B or D (class B or A) circuit (maximum IDC loop resistance is 25 Ohms). Install ELR across terminals 8 and 9 for Style D application.

FZM-1(A) OPERATION

Each FZM-1(A) uses one of the available module addresses on an SLC loop. It responds to regular polls from the control panel and reports its type and the status (open/normal/short) of its Initiating Device Circuit (IDC). A flashing LED indicates that the module is in communication with the control panel. The LED latches steady on alarm (subject to current limitations on the loop).

FZM-1(A) SPECIFICATIONS

Nominal operating voltage: 15 to 32 VDC.

Maximum current draw: 5.1 mA (LED on).

Maximum IDC wiring resistance: 25 Ohms.

Average operating current: 270 μ A, 1 communication and 1 LED flash every 5 seconds, 3.9k eol.

EOL resistance: 3.9K Ohms.

External supply voltage (between Terminals T10 and T11):

- DC voltage: 24 volts power limited.
- Ripple voltage: 0.1 Vrms maximum.
- Current: 90 mA per module maximum.

Temperature range: 32°F to 120°F (0°C to 49°C).



Humidity range: 10% to 93% noncondensing.

Dimensions: 4.5" (11.43 cm) high x 4" (10.16 cm) wide x 1.25" (3.175 cm) deep. Mounts to a 4" (10.16 cm) square x 2.125" (5.398 cm) deep box.

FDM-1(A) Dual Monitor Module

The FDM-1(A) Dual Monitor Module is intended for use in intelligent, two-wire systems. It provides two independent two-wire initiating device circuits (IDCs) at two separate, consecutive addresses. It is capable of monitoring normally open contact fire alarm and supervisory devices; or either normally open or normally closed security devices. The module has a single panel-controlled LED.

NOTE: The FDM-1(A) provides two Style B (Class B) IDC circuits ONLY. Style D (Class A) IDC circuits are NOT supported in any application.

FDM-1(A) SPECIFICATIONS

Normal operating voltage range: 15 to 32 VDC.

Maximum current draw: 6.4 mA (LED on).

Average operating current: 750 μ A (LED flashing).

Maximum IDC wiring resistance: 1,500 Ohms.

Maximum IDC Voltage: 11 Volts.

Maximum IDC Current: 240 μ A

EOL resistance: 47K Ohms.

Temperature range: 32° to 120°F (0° to 49°C).

Humidity range: 10% to 93% (non-condensing).

Dimensions: 4.5" (11.43 cm) high x 4" (10.16 cm) wide x 1.25" (3.175 cm) deep. Mounts to a 4" (10.16 cm) square x 2.125" (5.398 cm) deep box.

FDM-1(A) AUTOMATIC ADDRESSING

The FDM-1(A) automatically assigns itself to two addressable points, starting with the original address. For example, if the FDM-1(A) is set to address "26", then it will automatically assign itself to addresses "26" and "27".

NOTE: "Ones" addresses on the FDM-1(A) are 0, 2, 4, 6, or 8 only. Terminals 6 and 7 use the first address, and terminals 8 and 9 use the second address.



CAUTION:

Avoid duplicating addresses on the system.

Installation

FMM-1(A), FZM-1(A), and FDM-1(A) modules mount directly to a standard 4" (10.16 cm) square, 2.125" (5.398 cm) deep, electrical box. They may also be mounted to the SMB500 surface-mount box. Mounting hardware and installation instructions are provided with each module. All wiring must conform to applicable local codes, ordinances, and regulations. These modules are intended for power-limited wiring only.

The FMM-101(A) module is intended to be wired and mounted without rigid connections inside a standard electrical box. All wiring must conform to applicable local codes, ordinances, and regulations.

Agency Listings and Approvals

In some cases, certain modules may not be listed by certain approval agencies, or listing may be in process. Consult factory for latest listing status.

- **UL:** S635.
- **ULC:** S635.
- **FM Approved.**
- **CSFM:** 7300-0028:0219, 7165-0028:0224, 7165-0028:0243.
- **MEA:** 457-99-E.
- **U.S. Coast Guard:** 161.002/50/0 (NFS2-640, NFS2-320, NFS2-3030).
- **Lloyd's Register:** 11/600013 (NFS2-640, NFS2-320, NFS2-3030).
- **Fire Dept. of New York:** COA #6121 (NFS2-640, NFS-320), COA# 6114 (NFS2-3030).

Product Line Information

NOTE: "A" suffix indicates ULC-listed model.

FMM-1(A): Monitor module.

FMM-101(A): Monitor module, miniature.

FZM-1(A): Monitor module, two-wire detectors.

FDM-1(A): Monitor module, dual, two independent Class B circuits.

SMB500: Optional surface-mount backbox.

NOTE: See installation instructions and refer to the SLC Wiring Manual, PN 51253.



Reviewed for Code Compliance
Permitting and Inspections Department
Approved with Conditions

05/13/2020



Reviewed for Code Compliance
Permitting and Inspections Department
Approved with Conditions

05/13/2020

FlashScan® and NOTIFIER® are registered trademarks and FireWatch™ is a trademark of Honeywell International Inc.
©2015 by Honeywell International Inc. All rights reserved. Unauthorized use of this document is strictly prohibited.



This document is not intended to be used for installation purposes.
We try to keep our product information up-to-date and accurate.
We cannot cover all specific applications or anticipate all requirements.
All specifications are subject to change without notice.

For more information, contact Notifier. Phone: (203) 484-7161, FAX: (203) 484-7118.
www.notifier.com

FCM-1(A) & FRM-1(A) Series

Control and Relay Modules



Intelligent / Addressable Devices

General

FCM-1(A) Control Module: The FCM-1(A) Addressable Control Module provides Notifier intelligent fire alarm control panels a circuit for Notification Appliances (horns, strobes, speakers, etc.). Addressability allows the FCM-1(A) to be activated, either manually or through panel programming, on a select (zone or area of coverage) basis.

FRM-1(A) Relay Module: The FRM-1(A) Addressable Relay Module provides the system with a dry-contact output for activating a variety of auxiliary devices, such as fans, dampers, control equipment, etc. Addressability allows the dry contact to be activated, either manually or through panel programming, on a select basis.

FlashScan® (U.S. Patent 5,539,389) is a communication protocol developed by NOTIFIER Engineering that greatly enhances the speed of communication between analog intelligent devices. Intelligent devices communicate in a grouped fashion. If one of the devices within the group has new information, the panel CPU stops the group poll and concentrates on single points. The net effect is response speed greater than five times that of other designs.

Features

- Built-in type identification automatically identifies these devices to the control panel.
- Internal circuitry and relay powered directly by two-wire SLC loop. The FCM-1(A) module requires power (for horns, strobes, etc.), or audio (for speakers).
- Integral LED “blinks” green each time a communication is received from the control panel and turns on in steady red when activated.
- LED blink may be deselected globally (affects all devices).
- High noise immunity (EMF/RFI).
- The FCM-1(A) may be used to switch 24-volt NAC power, audio (up to 70.7 Vrms).
- Wide viewing angle of LED.
- SEMS screws with clamping plates for wiring ease.
- Direct-dial entry of address 01– 159 for FlashScan loops, 01 – 99 for CLIP mode loops.
- Speaker, and audible/visual applications may be wired for Class B or A (Style Y or Z).

Applications

The FCM-1(A) is used to switch 24 VDC audible/visual power, high-level audio (speakers). The FRM-1(A) may be programmed to operate dry contacts for applications such as door holders or Air Handling Unit shutdown, and to reset four-wire smoke detector power.

NOTE: Refer to the SLC Manual (PN 51253) for details regarding releasing applications with the FCM-1(A). Refer to the FCM-1-REL datasheet (DN-60390) for new FlashScan® releasing applications.

Construction

- The face plate is made of off-white heat-resistant plastic.
- Controls include two rotary switches for direct-dial entry of address (01-159).

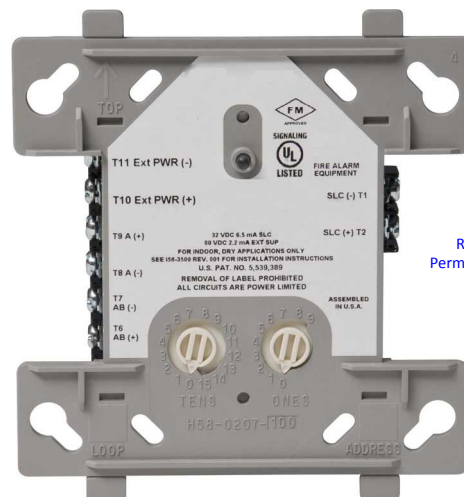

FCM-1(A)



Reviewed for Code Compliance
Permitting and Inspections Department
Approved with Conditions

05/13/2020

- The FCM-1(A) is configured for a single Class B (Style Y) or Class A (Style Z) Notification Appliance Circuit.
- The FRM-1(A) provides two Form-C dry contacts that switch together.

Operation

Each FCM-1(A) or FRM-1(A) uses one of 159 possible module addresses on a SLC loop (99 on CLIP loops). It responds to regular polls from the control panel and reports its type and status, including the open/normal/short status of its Notification Appliance Circuit (NAC). The LED blinks with each poll received. On command, it activates its internal relay. The FCM-1(A) supervises Class B (Style Y) or Class A (Style Z) notification or control circuits.

Upon code command from the panel, the FCM-1(A) will disconnect the supervision and connect the external power supply in the proper polarity across the load device. The disconnection of the supervision provides a positive indication to the panel that the control relay actually turned ON. The external power supply is always relay isolated from the communication loop so that a trouble condition on the external power supply will never interfere with the rest of the system.

Rotary switches set a unique address for each module. The address may be set before or after mounting. The built-in TYPE CODE (not settable) will identify the module to the control panel, so as to differentiate between a module and a sensor address.

Specifications for FCM-1(A)

Normal operating voltage: 15 to 32 VDC.

Maximum current draw: 6.5 mA (LED on).

Average operating current: 350 μ A direct poll, 375 μ A group poll with LED flashing, 485 μ A Max. (LED flashing, NAC shorted.)

Maximum NAC Line Loss: 4 VDC.

External supply voltage (between Terminals T10 and T11): Maximum (NAC): Regulated 24 VDC; Maximum (Speakers): 70.7 V RMS, 50W.

Drain on external supply: 1.7 mA maximum using 24 VDC supply; 2.2 mA Maximum using 80 VRMS supply.

Max NAC Current Ratings: For class B wiring system, the current rating is 3A; For class A wiring system, the current rating is 2A.

Temperature range: 32°F to 120°F (0°C to 49°C).

Humidity range: 10% to 93% non-condensing.

Dimensions: 4.5" (114.3 mm) high x 4" (101.6 mm) wide x 1.25" (31.75 mm) deep. Mounts to a 4" (101.6 mm) square x 2.125" (53.975 mm) deep box.

Accessories: SMB500 Electrical Box; CB500 Barrier

Specifications for FRM-1(A)

Normal operating voltage: 15 to 32 VDC.

Maximum current draw: 6.5 mA (LED on).

Average operating current: 230 µA direct poll; 255 µA group poll.

EOL resistance: not used.

Temperature range: 32°F to 120°F (0°C to 49°C).

Humidity range: 10% to 93% non-condensing.

Dimensions: 4.5" (114.3 mm) high x 4" (101.6 mm) wide x 1.25" (31.75 mm) deep. Mounts to a 4" (101.6 mm) square x 2.125" (53.975 mm) deep box.

Accessories: SMB500 Electrical Box; CB500 Barrier

Agency Listings and Approvals

In some cases, certain modules may not be listed by certain approval agencies, or listing may be in process. Consult factory for latest listing status.

- **UL:** S635
- **ULC:** S3705 (A version only)
- **FM Approved**
- **CSFM:** 7300-0028:0219
- **MEA:** 14-00-E
- **FDNY:** COA #6067, #6065

Contact Ratings for FRM-1(A)

Current Rating	Maximum Voltage	Load Description	Application
3 A	30 VDC	Resistive	Non-Coded
2 A	30 VDC	Resistive	Coded
.9 A	110 VDC	Resistive	Non-Coded
.9 A	125 VDC	Resistive	Non-Coded
.5 A	30 VDC	Inductive (L/R=5ms)	Coded
1 A	30 VDC	Inductive (L/R=2ms)	Coded
.3 A	125 VAC	Inductive (PF=0.35)	Non-Coded
1.5 A	25 VAC	Inductive (PF=0.35)	Non-Coded
.7 A	70.7 VAC	Inductive (PF=0.35)	Non-Coded
2 A	25 VAC	Inductive (PF=0.35)	Non-Coded

NOTE: Maximum (Speakers): 70.7 V RMS, 50 W

Product Line Information

NOTE: "A" suffix indicates ULC Listed model.

FCM-1(A): Intelligent Addressable Control Module.

FRM-1(A): Intelligent Addressable Relay Module.

A2143-20: Capacitor, required for Class A (Style Z) operation of speakers.

SMB500: Optional Surface-Mount Backbox.

CB500: Control Module Barrier — required by UL for separating power-limited and non-power limited wiring in the same junction box as FCM-1(A).

NOTE: For installation instructions, see the following documents:

- *FCM-1(A) Installation document I56-1169.*
- *FRM-1(A) Installation document I56-3502.*
- *Notifier SLC Wiring Manual, document 51253.*



Reviewed for Code Compliance
Permitting and Inspections Department
Approved with Conditions

05/13/2020

Notifier® and **FlashScan®** are registered trademarks of Honeywell International Inc.

©2011 by Honeywell International Inc. All rights reserved. Unauthorized use of this document is strictly prohibited.



This document is not intended to be used for installation purposes.
We try to keep our product information up-to-date and accurate.
We cannot cover all specific applications or anticipate all requirements.
All specifications are subject to change without notice.



Made in the U.S.A.

For more information, contact Notifier. Phone: (203) 484-7161, FAX: (203) 484-7118.
www.notifier.com

XP6-MA(A)

Six Zone Interface Module



Intelligent/Addressable Devices

General

NOTIFIER's **XP6-MA six-zone interface module** provides an interface between the intelligent alarm system and a two-wire conventional detection zone. A common SLC input is used for all modules, and the initiating device circuits share a common external supervisory supply and ground. Otherwise, each module operates independently from the others.

The first module is addressed from 01 to 154 while the remaining modules are automatically assigned to the next five higher addresses. Provisions are included for disabling a maximum of two unused modules. All two-wire detectors being monitored must be two-wire-compatibility-listed with the modules. The XP6-MA transmits the status of a zone of two-wire detectors to the fire alarm control panel. Status conditions are reported as normal, open, or alarm. The interface module supervises the zone of detectors and the connection of the external power supply.

Each XP6-MA module has panel-controlled bicolor LED indicators. The panel can cause the LEDs to blink, latch on, or latch off.

Features

- Six addressable Class B or three addressable Class A initiating device circuits.
- Removable 12 AWG (3.1 mm²) to 18 AWG (0.78 mm²) plug-in terminal blocks.
- Status indicators for each point.
- Up to two unused addresses may be disabled.
- Rotary address switches.
- Class A or Class B operation.
- FlashScan® or CLIP operation.
- Mount one or two modules in a BB-XP cabinet (optional).
- Mount up to six modules on a CHS-6 chassis in a CAB-3 Series, CAB-4 Series, BB-25 cabinet (optional), or EQ Cabinet Series.
- Mounting hardware included.

Specifications

Standby current: 2.0 mA (SLC current draw with all addresses used; if some addresses are disabled, the standby current decreases).

Alarm current: 40 mA (assumes all six LEDs solid ON).

Temperature range: 32°F to 120°F (0°C to 49°C).

Humidity: 10% to 85% noncondensing.

Dimensions: 6.8" (172.72 mm) high x 5.8" (147.32 mm) wide x 1.25" (31.75 mm) deep.

Shipping weight: 1.1 lb. (0.499 kg) including packaging.

Mounting options: CHS-6 chassis, BB-XP cabinet, BB-25 cabinet, CAB-3 Series cabinet (see DN-3549), CAB-4 Series cabinet (see DN-6857), or EQ series cabinet (see DN-60262).

Wire gauge: 12 AWG (3.1 mm²) to 18 AWG (0.78 mm²).

XP6-MA is shipped in Class B position: Remove shunt for Class A operation.

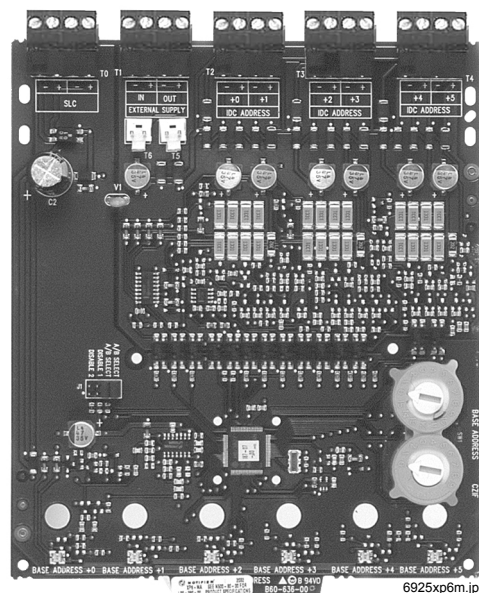

6925xp6m.jpg

Maximum SLC wiring resistance: 40 or 50 ohms, panel dependent.

Maximum IDC wiring resistance: 25 ohms.

External supply voltage: DC voltage: 18 – 28 volts power-limited. Ripple voltage: 0.1 Vrms maximum. External supply current: 90 mA maximum per address in alarm. In Class B operation, 540 mA maximum for all six addresses in alarm. In Class A operation, 270 mA maximum for all three addresses in alarm.

Compatible detectors: See the *Notifier Device Compatibility Document*.

Agency Listings and Approvals

These listings and approvals apply to the modules specified in this document. In some cases, certain modules or applications may not be listed by certain approval agencies, or listing may be in process. Consult factory for latest listing status.

- **UL Listed:** S635 (XP6-MA).
- **ULC Listed:** S635 (XP6-MAA).
- **MEA Listed:** 386-02-E.
- **CSFM:** 7300-0028:0219, 7165-0028:0243.
- **FM Approved.**
- **FDNY:** COA#6085, #6121.
- **City of Chicago.**
- **City of Denver.**



Reviewed for Code Compliance
Permitting and Inspections Department
Approved with Conditions

05/13/2020

Product Line Information

XP6-MA: Six-zone conventional-detector interface module.

XP6-MAA: Same as above with ULC Listing.



BB-XP: Optional cabinet for one or two modules. Dimensions, DOOR: 9.234" (23.454 cm) wide (9.484" [24.089 cm] including hinges), x 12.218" (31.0337 cm) high, x 0.672" (1.7068 cm) deep; BACKBOX: 9.0" (22.860 cm) wide (9.25" [23.495 cm] including hinges), x 12.0" (30.480 cm) high x 2.75" (6.985 cm); CHASSIS (installed): 7.150" (18.161 cm) wide overall x 7.312" (18.5725 cm) high interior overall x 2.156" (5.4762 cm) deep overall.

BB-25: Optional cabinet for up to six modules mounted on CHS-6 chassis (below). Dimensions, DOOR: 24.0" (60.96 cm) wide x 12.632" (32.0852 cm) high, x 1.25" (3.175 cm) deep, hinged at bottom; BACKBOX: 24.0" (60.96 cm) wide x 12.550" (31.877 cm) high x 5.218" (13.2537 cm) deep.

CHS-6: Chassis, mounts up to six modules in a CAB-3 Series (see DN-3549) CAB-4 Series (see DN-6857) cabinet, EQ Cabinet Series (see DN-60229), or BB-25.

NOTIFIER® and **FlashScan®** are registered trademarks of Honeywell International Inc.
©2013 by Honeywell International Inc. All rights reserved. Unauthorized use of this document is strictly prohibited.



This document is not intended to be used for installation purposes.
We try to keep our product information up-to-date and accurate.
We cannot cover all specific applications or anticipate all requirements.
All specifications are subject to change without notice.



Made in the U.S. A.

For more information, contact Notifier. Phone: (203) 484-7161, FAX: (203) 484-7118.
www.notifier.com

FCPS-24S6 & FCPS-24S8 Series Remote Power Supplies

The FCPS-24S6 Series (6-amp) and FCPS-24S8 Series (8-amp) are remote power supplies with battery charger. The FCPS-24S6/-24S8 may be connected to any 12 or 24 volt fire alarm control panel (FACP) or may be used as stand-alone supplies. Primary applications include notification appliance circuit (NAC) expansion (to support ADA requirements and NAC synchronization) or auxiliary power to support 24 volt system accessories. The FCPS-24S6/-24S8 provides regulated and filtered 24 VDC power to four notification appliance circuits configured as either four Class B (Style Y) or Class A (Style Z, with ZNAC-4 option module). Alternately, the four outputs may be configured as all non-resettable, all resettable or two non-resettable and two resettable. The FCPS-24S6/-24S8 also contains a battery charger capable of charging up to 18 AH batteries. The FCPS-24S6C and FCPS-24S8C are ULC-listed.

NOTE: Unless otherwise specified, the terms FCPS-24S6 and FCPS-24S8 used in this document refers to the FCPS-24S6 and FCPS-24S8, FCPS-24S6C and FCPS-24S8C, the FCPS-24S6E and FCPS-24S8E.

Features

- UL-Listed NAC synchronization using System Sensor®, Wheelock®, or Gentex® “Commander²” appliances
- Operates as a “sync-follower” or as a “sync-generator” (default) See note on page 2.
- Contains two fully-isolated input/control circuits - triggered from FACP NAC (NAC expander mode) or jumped permanently “ON” (stand-alone mode)
- Four Class B (Style Y) or four Class A (Style Z, with ZNAC-4 module) NACs
- 6-amp (FCPS-24S6) or 8-amp (FCPS-24S8) full load output, with 3 amps maximum/circuit, in NAC expander mode (UL 864)
- 4-amp (FCPS-24S6) or 6-amp (FCPS-24S8) continuous output in stand-alone mode (UL 1481)
- Compatible with coded inputs; signals passed through
- Optional power-supervision relay (EOLR-1)
- In stand-alone mode, output power circuits may be configured as: resettable, (reset line from FACP required), non-resettable, or a mix of two and two
- Fully regulated and filtered power output - optimal for powering four-wire smoke detectors, annunciators, and other system peripherals requiring regulated/filtered power
- Power-limiting technology meets UL power-limiting requirements
- Form-C normally-closed trouble relay
- Fully supervised power supply, battery, and NACs
- Selectable earth fault detection
- AC trouble report selectable for immediate 2-hour delay
- Works with virtually any UL 864 fire alarm control which utilizes an industry-standard reverse-polarity notification circuit (including unfiltered and unregulated NAC power)
- Requires input trigger voltage of 9 - 32 VDC
- Self-contained in compact, locking cabinet - 15”H x 14.5”W x 2.75”D (cm: 38.1H x 36.83W x 6.985D)
- Includes integral battery charger capable of charging up to 18 AH batteries. Cabinet capable of housing 7.0 AH batteries
- Battery charger may be disabled via DIP switch for applications requiring larger batteries
- Fixed, clamp-type terminal blocks accommodate up to 12 AWG (3.1mm²) wire



Specifications

Primary (AC) Power:

- **FCPS-24S6/-24S8:** 120 VAC, 60 Hz, 3.2A maximum
- **FCPS-24S6C/-24S8C:** 120 VAC, 60 Hz, 3.2A maximum
- **FCPS-24S6E/-24S8E:** 240 VAC, 50 Hz, 1.6A maximum
- Wire Size: minimum #14 AWG (2.0mm²) with 600 V insulation

Control Input Circuit:

- **Trigger Input Voltage:** 9 to 32 VDC
- **Trigger Current:** 2.0 mA (16 - 32 V); Per Input: 1.0 mA (9 - 16 V)

Trouble Contact Rating: 5 A at 24 VDC

Auxiliary Power Output: Special application power 500 mA maximum

Output Circuits:

- +24 VDC filtered, regulated
- 3.0 A maximum for any one circuit
- Total continuous current for all outputs (stand-alone mode):
 - FCPS-24S6: 4.0 A maximum
 - FCPS-24S8: 6.0 A maximum
- Total short-term current for all outputs (NAC expander mode):
 - FCPS-24S6: 6.0 A maximum
 - FCPS-24S8: 8.0 A maximum

Secondary Power (Battery) Charging Circuit:

- Supports lead-acid batteries only
- Float-charge voltage: 27.6 VDC
- Maximum current charge: 1.5 A
- Maximum battery capacity: 18 AH



Applications

Example 1: Expand notification appliance power an additional 6.0 A (FCPS-24S6) or 8.0 A (FCPS-24S8). Use up to four Class B (Style Y) outputs or four Class A (Style Z) outputs (using ZNAC-4). For example, the FACP notification appliance circuits will activate the FCPS when reverse-polarity activation occurs. Trouble conditions on the FCPS are sensed by the FACP through the notification appliance circuit.

Example 2: Use the FCPS to expand auxiliary regulated 24-volt system power up to 4.0 A (FCPS-24S6) or up to 6.0 A (FCPS-24S8). Both resettable and non-resettable power options are available. Resettable outputs are created by connecting the resettable output from the FACP to one or both of the FCPS inputs.

Example 3: Use addressable control modules to activate the FCPS instead of activating it through the FACP notification appliance circuits. This typically allows for mounting the FCPS at greater distances* away from the FACP while expanding system architecture in various applications.

For example, an addressable control module is used to activate the FCPS, and an addressable monitor module is used to sense FCPS trouble conditions. Local auxiliary power output from the FCPS provides power to the addressable control module.

NOTE: Addressable FACP's are capable of locating control and monitor modules at distances of up to 12,500 feet (3,810 meters).

Sync Follower/Generator Note

In some installations, it is necessary to synchronize the flash timing of all strobes in the system for ADA compliance. Strobes accomplish this by monitoring very short timing pulses on the NAC power which are created by the FACP. When installed at the end of a NAC wire run, the FCPS-24S6/-24S8 can track (i.e. "follow") the strobe synchronization timing pulses on the existing NAC wire run. This maintains the overall system flash timing of the additional strobes attaches to the FCPS.

When the FCPS-24S6/-24S8 is configured (via DIP switch settings) as a "sync follower," the FCPS' NAC outputs track the strobe synchronization pulses present at the FCPS' sync input terminal. The pulses originate from an upstream FACP or other power supply.

When the FCPS-24S6/-24S8 are configured (via DIP switch settings) as a "sync generator," the FCPS' sync input terminals are not used. Rather, the FCPS is the originator of the strobe synchronization pulses on the FCPS' NAC outputs. In "sync generator" mode, the sync type (System Sensor, Wheelock, or Gentex) is selectable via DIP switch settings.

Standards and Codes

The FCPS-24S6 and FCPS-24S8 comply with the following standards:

- **NFPA 72** National Fire Alarm Code
- **UL 864** Standard for Control Units for Fire Alarm Systems (NAC expander mode)
- **UL 1481** Power Supplies for Fire Alarm Systems

Agency Listings and Approvals

These listings and approvals apply to the modules specified in this document. In some cases, certain modules or applications may not be listed by certain approval agencies, or listing may be in process. Consult factory for latest listing status.

- **UL Listed:** S635, S674
- **ULC Listed:** S635 (FCPS-24S6C & FCPS-24S8C)
- **CSFM Approved:** 7315-0028:0225
- **MEA:** 299-02-E
- **FM Approved**

Ordering Information

FCPS-24S6: 6.0 A, 120 VAC remote charger power supply. Includes main printed circuit board, transformers, enclosure (15"H x 14.5"W x 2.75"D [cm: 38.1H x 36.83W x 6.985D]), and installation instructions

FCPS-24S6C: Same as above, ULC-listed

FCPS-24S6R: Same as FCPS-24S6 with red enclosure

FCPS-24S6E: 6.0 A, 240 VAC remote charger power supply. Includes main printed circuit board, transformers, enclosure (15"H x 14.5"W x 2.75"D [cm: 38.1H x 36.83W x 6.985D]), and installation instructions

FCPS-24S8: 8.0 A, 120 VAC remote charger power supply. Includes main printed circuit board, transformers, enclosure (15"H x 14.5"W x 2.75"D [cm: 38.1H x 36.83W x 6.985D]), and installation instructions

FCPS-24S8C: Same as above, ULC-listed

FCPS-24S8R: Same as FCPS-24S8 with red enclosure

FCPS-24S8E: 8.0 A, 240 VAC remote charger power supply. Includes main printed circuit board, transformers, enclosure (15"H x 14.5"W x 2.75"D [cm: 38.1H x 36.83W x 6.985D]), and installation instructions

ZNAC-4: Class A (Style Y) NAC option module

EOLR-1: 12/24 VDC end-of-line relay for monitoring four-wire smoke detector power

BAT-1270: Battery, 12-volt, 7.0 AH (two required, see BAT Series data sheet DN-6933)

PS-1270: Battery, 12-volt, 7.0 AH (two required)



This document is not intended to be used for installation purposes.
We try to keep our product information up-to-date and accurate.
We cannot cover all specific applications or anticipate all requirements.
All specifications are subject to change without notice.

NOTIFIER® and System Sensor® are registered trademarks of Honeywell International Inc. Wheelock® is a registered trademark of Cooper Technologies Company. Gentex® is a registered trademark of Gentex Corporation.

©2019 by Honeywell International Inc. All rights reserved. Unauthorized use of this document is strictly prohibited.

Country of Origin: USA



Reviewed for Code Compliance
Permitting and Inspections Department
Approved with Conditions

05/13/2020



NOTIFIER

12 Clintonville Road
Northford, CT 06472
203.484.7161
www.notifier.com

Specifications

Nominal Voltage	12V	
Nominal Capacity (20HR)	7AH	
Dimension	Length	151mm (5.95 inches)
	Width	65mm (2.56 inches)
	Height	94mm (3.70 inches)
	Total Height (with Terminal)	100mm (3.94 inches)
	Approximate Weight	2.05 kg (4.52 lbs)
Battery Type	Valve Regulated Lead-Acid Battery, AGM Design	
Terminal Type	T1	
Rated Capacity	7.20AH	(20hr, 1.75V/cell, 25°C/77°F)
	6.70AH	(10hr, 1.75V/cell, 25°C/77°F)
	5.95AH	(5hr, 1.75V/cell, 25°C/77°F)
	6.54AH	(3hr, 1.60V/cell, 25°C/77°F)
	4.20AH	(1hr, 1.60V/cell, 25°C/77°F)
Max. Discharge Current	105A	
Internal Resistance	30mΩ	
Operating Temp. Range	Discharge:	-20°C(-4°F)~50°C (122°F)
	Charge:	-20°C(-4°F)~50°C (122°F)
	Storage:	-20°C(-4°F)~40°C (104°F)
Nominal Operating Temp. Range	25±3°C (77±5°F)	
Container Material	ABS (Option: 94-HB & 94-V0 flame retardant case)	
Capacity affected by Temperature	40°C (104°F)	103%
	25°C (77°F)	100%
	0°C (32°F)	86%
Self Discharge	SigmasTek SP series batteries may be stored for up to 6 months at 25°C (77°F) and then a freshening charge is recommended. For higher temperatures the time interval will be shorter.	



Applications

- Uninterruptible Power Supply (UPS)
- Electric wheelchairs, scooters, bikes
- Electronic apparatus and equipment
- Alarm and security systems
- Emergency first responder equipment
- Emergency lighting
- Medical devices
- Electric carts
- Telecom equipment
- Switchgear
- Solar power systems



Constant Current Discharge (Amperes Per Battery) at 25°C (77°F)

F.V. (V/cell) \ Discharge Time	5min	10min	15min	30min	1h	2h	3h	5h	8h	10h	20h
1.60V	27.6	17.6	12.8	7.83	4.20	2.55	2.18	1.29	0.79	0.70	0.39
1.65V	25.6	17.2	12.4	7.50	4.16	2.50	1.85	1.26	0.78	0.70	0.37
1.70V	23.7	17.1	12.0	6.80	4.00	2.45	1.75	1.23	0.78	0.67	0.36
1.75V	23.4	16.5	11.7	6.48	3.92	2.42	1.70	1.19	0.77	0.67	0.36
1.80V	20.7	15.4	10.6	6.00	3.65	2.36	1.67	1.18	0.76	0.66	0.35
1.85V	20.5	13.8	10.5	5.88	3.52	2.20	1.50	1.11	0.72	0.65	0.34

Constant Power Discharge (Watts Per Cell) at 25°C (77°F)

F.V. (V/cell) \ Discharge Time	5min	10min	15min	30min	1h	2h	3h	5h	8h	10h	20h
1.60V	302	197	150	87	49.1	24.4	19.1	13.0	9.00	7.24	3.81
1.65V	291	189	147	86	48.7	25.2	19.0	13.0	8.94	7.24	3.81
1.70V	280	186	146	85	48.0	25.0	18.9	12.9	8.81	7.22	3.80
1.75V	264	179	141	83	47.2	24.4	18.7	12.9	8.71	7.18	3.79
1.80V	228	171	135	80	45.8	23.6	18.4	12.7	8.57	7.18	3.72
1.85V	226	160	125	74	40.0	21.0	17.0	12.0	8.10	6.90	3.70

Dimensions

T1 Terminal

Unit: mm (inches)

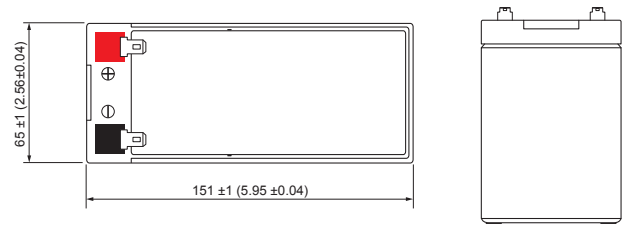
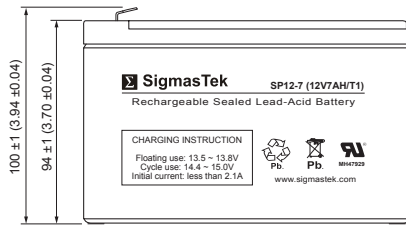
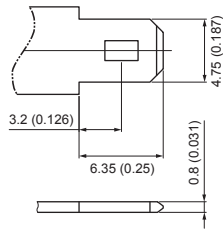

Cycle Service Life

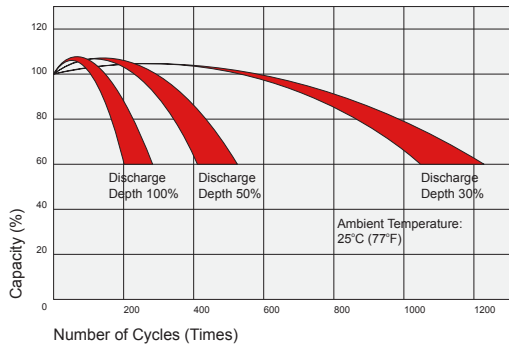

Reviewed for Code Compliance
Permitting and Inspections
Department
~ 05/13/2020 ~

Self Discharge Characteristics

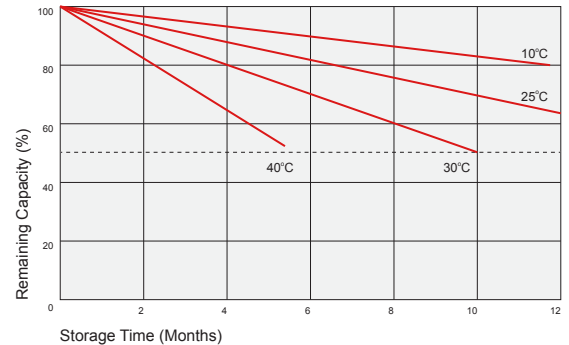

Discharge Characteristics

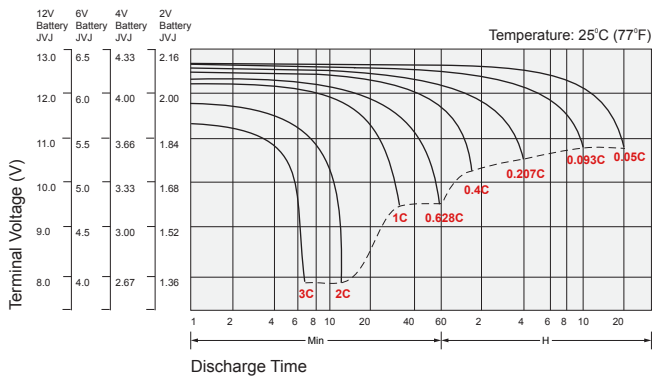

Float Charging Characteristics

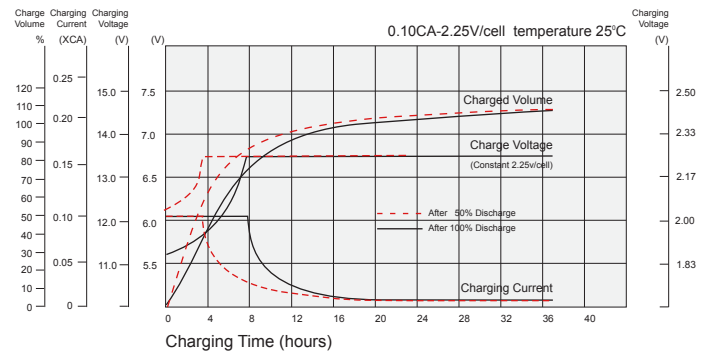

Temperature Effects in Relation to Battery Capacity

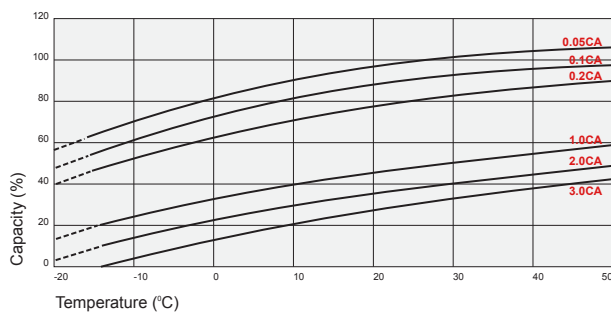

Temperature Effects on Long Term Float Life

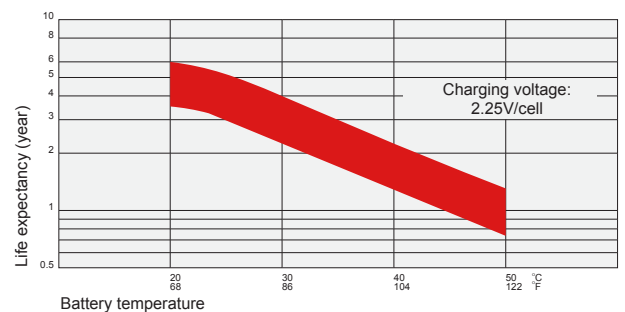

Contact Information

SigmasTek
7651 W 100th Place
Bridgeview, IL 60455, USA

T: (888) 988-8290
www.sigmastek.com
order@sigmastek.com

Commander³ Series Selectable Candela Evacuation Signals

Applications

The Commander³ Series is a low profile strobe and horn/strobe combination that offers dependable audible and visual alarms and the absolute lowest current available.

The GE3 Series 24VDC offers tamperproof field selectable candela options of 15, 30, 60, 75, and 110 candela. The 12VDC offers tamperproof field selectable candela options of 15, 30, 60, and 75 candela.

The Commander³ Series horn offers a continuous or synchable temporal three in 2400Hz and mechanical tone, a chime and whoop tone. All tones are easy for the professional to change in the field by the use of switches.

The GE3 Series has a minimal operating current and has a minimum flash rate of 1Hz regardless of input voltage.

The Commander³ Series is shipped with a standard 4" metal mounting plate which incorporates the popular Super-Slide[®] feature that allows the installer to easily test for supervision. The product also features a locking mechanism which secures the product to the bracket without any screws showing.

The Commander³ also features the patented Checkmate[®] - Instant Voltage Verification feature which allows the installer to check the voltage drop draw and match it to the blueprint.

The GE3 Series appliances are ANSI/UL 464 and ANSI/UL 1971, listed for use with fire protective systems and are warranted for three years from date of purchase.

Standard Features

- Nominal voltage 12VDC and 24VDC
- 24VDC units have field selectable candela options of 15, 30, 60, 75 & 110
- 12VDC units have field selectable candela options of 15, 30, 60 & 75
- GEH horn is available in 12VDC or 24VDC
- Unit Dimensions: 5" (12.7 cm) high x 4.5" (11.43 cm) wide x 2.5" (6.35 cm) deep
- Super-Slide[®] Bracket - Ease of Supervision Testing
- Checkmate[®] - Instant Voltage Verification
- Synchronize strobe and/or horn with Gentex AVSM Control Module
- Prewire entire system, install mounting bracket, then install signals
- Documented lower installation and operating costs
- Input terminals accept 12 to 18 AWG
- Switch selection for high or low dBA
- Switch for chime, whoop, mechanical and 2400Hz tone
- Tamperproof re-entrant style grill
- Switch for continuous or temporal 3 tone (not available on whoop tone)
- Surface mount with the GSB (Gentex Surface Mount Box)
- Silence audible while visual appliance will remain flashing (for use in accepted jurisdictions)
- Faceplate available in red or off-white

GEC3/GES3 12 & 24 VDC S E R I E S



Product Listings

SIGNALING



- ANSI/UL 464 & ANSI/UL 1971 Listed
- CSFM: 7135-0569:122 (GEC3-24 & GEH-24)
7125-0569:123 (GES3-24)
7125-0569:129 (GES3-12)
7135-0569:130 (GEC3-12 & GEH-12)
- MEA: 285-91-E (GEC3-24 & GES3-24)
580-06-E (GEC3-12 & GES3-12)

Patents

- 7,375,617 May 20, 2008

Product Compliance

- NFPA 72
- Americans with Disabilities Act (ADA)
- IBC/IFC/IRC
- Quality Management System is certified to: ISO 9001:2008



ASSEMBLED IN
THE USA



Reviewed for Code Compliance
Permitting and Inspections Department
Approved with Conditions

05/13/2020



Reviewed for Code Compliance
Permitting and Inspections Department
Approved with Conditions
05/13/2020

GEH 12VDC or 24VDC Low Profile Evacuation Horn

Model Number	Part Number	Nominal Voltage	Reverberant dBA at 10ft., per ANSI/UL 464	In Anechoic Room dBA at 10ft.
GEH12-R	904-1239-002	12VDC	62-82	100
GEH12-W	904-1241-002	12VDC	62-82	100
GEH24-R	904-1205-002	24VDC	62-82	100
GEH24-W	904-1207-002	24VDC	62-82	100

GES3 12VDC or 24VDC Selectable Candela, Low Profile Evacuation Strobe

Model Number	Part Number	Nominal Voltage	Candela (ANSI/UL 1971)
GES3-12WR	904-1235-002	12 VDC	15, 30, 60, 75
GES3-12WW	904-1237-002	12 VDC	15, 30, 60, 75
GES3-24WR	904-1321-002	24 VDC	15, 30, 60, 75, 110
GES3-24WW	904-1319-002	24 VDC	15, 30, 60, 75, 110

GEC3 12VDC or 24VDC Selectable Candela, Low Profile Evacuation Horn/Strobe

Model Number	Part Number	Nominal Voltage	Candela (ANSI/UL 1971)	Reverberant dBA at 10ft., per ANSI/UL 464	In Anechoic Room dBA at 10ft.
GEC3-12WR	904-1231-002	12 VDC	15, 30, 60, 75	62-82	100
GEC3-12WW	904-1233-002	12 VDC	15, 30, 60, 75	62-82	100
GEC3-24WR	904-1317-002	24 VDC	15, 30, 60, 75, 110	62-82	100
GEC3-24WW	904-1315-002	24 VDC	15, 30, 60, 75, 110	62-82	100

GE3 Product Strobe Current Ratings (mA)				
	12 VDC (8-17.5 Volts)		24 VDC (16-33 Volts)	
Candela	12VDC	UL Max ¹	24VDC	UL Max ¹
15cd	106mA	92mA	30mA	42mA
30cd	131mA	141mA	35mA	58mA
60cd	186mA	260mA	66mA	97mA
75cd	237mA	312mA	80mA	116mA
110cd			103mA	161mA

Model Designations:

W = Wall mount
R = Red Faceplate W = White Faceplate

All units are available in plain (no lettering).
Plain units are non-returnable.

ALERT bezel available for order
AGENT bezel available for order

GE3-12 Product Horn Current Ratings			
Horn Mode	Horn Decibel Levels		Regulated 12VDC Max. Operating @ High Setting (mA)
	Minimum SPL at 10ft., per ANSI/UL 464 (HIGH)	Minimum SPL at 10ft., per ANSI/UL 464 (LOW)	
Temp 3 2400Hz	76 dBA	69* dBA	29mA
Temp 3 Mechanical	75 dBA	68* dBA	26mA
Temp 3 Chime	62* dBA	60* dBA	13mA
Continuous 2400Hz	79 dBA	74* dBA	29mA
Continuous Mechanical	78 dBA	72* dBA	26mA
Continuous Chime	63* dBA	61* dBA	13mA
Whoop	78 dBA	71* dBA	55mA

GE3-24 Product Horn Current Ratings			
Horn Mode	Horn Decibel Levels		Regulated 24VDC Max. Operating @ High Setting (mA)
	Minimum SPL at 10ft., per ANSI/UL 464 (HIGH)	Minimum SPL at 10ft., per ANSI/UL 464 (LOW)	
Temp 3 2400Hz	78 dBA	71* dBA	28mA
Temp 3 Mechanical	76 dBA	70* dBA	25mA
Temp 3 Chime	70* dBA	66* dBA	15mA
Continuous 2400Hz	81 dBA	74* dBA	28mA
Continuous Mechanical	80 dBA	72* dBA	25mA
Continuous Chime	70* dBA	66* dBA	15mA
Whoop	82 dBA	69* dBA	56mA

NOTES:

- Operating temperature: 32° to 120°F (0° to 49°C). The GEC3 and GES3 Series is **not** listed for outdoor use.
- For nominal and peak current across ANSI/UL regulated voltage range for filtered DC power and unfiltered (FWR [Full Wave Rectified]) power, see installation manual. 12VDC models are DC only.
- Gentex does not recommend using a coded or pulsing signaling circuit with any of our strobe products (see Technical Bulletin Number 014).**
- The sound output for the temporal 3 tone is rated lower since the time the horn is off is averaged into the sound output rating. While the horn is producing a tone in the temporal 3 mode its sound pressure is the same as the continuous mode.
- * Operating the horn in this mode at this voltage will result in not meeting the minimum ANSI/UL 464 reverberant sound level required for public mode fire protection service. These settings are acceptable only for private mode fire alarm use. Use the high dBA setting for public mode application (not applicable when using the chime tone. The chime tone is always private mode).

¹ RMS current ratings are per ANSI/UL average RMS method. ANSI/UL max current rating is the maximum RMS current within the listed voltage range (16-33VDC for 24VDC units) (8-17VDC for 12VDC units). For strobes the UL max current is usually at the minimum listed voltage (16VDC for 24VDC units) (8VDC for 12VDC units). For audibles the max current is usually at the maximum listed voltage. For unfiltered FWR ratings, see installation manual.



Tone Switch Locations

TONE	SWITCH POSITION		
	3	4	5
Mechanical Temporal 3	ON	ON	ON
Mechanical - Continuous	OFF	ON	ON
2400Hz - Temporal 3	ON	OFF	ON
2400Hz - Continuous	OFF	OFF	ON
Chime - Temporal 3	ON	ON	OFF
Chime - Continuous	OFF	ON	OFF
Whoop	ON	OFF	OFF
Whoop	OFF	OFF	OFF

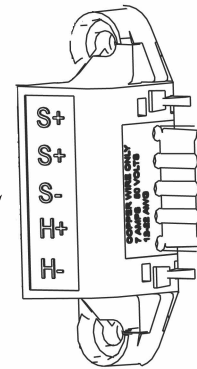
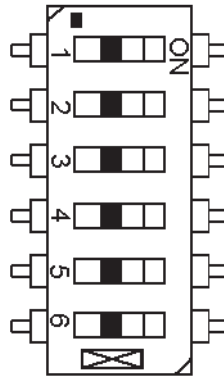

NOTE:

- Switch Positions 1 and 2 in the OFF position to select isolated horn and strobe power inputs
- Switch Position 6 ON = HIGH dBA
- Switch Position 6 OFF = LOW dBA

Gentex Super-Slide® Mounting Bracket

Allows the installer to pre-wire the system, test for system supervision, remove the signal head until occupancy, switch out Gentex signals without changing mounting brackets and has locking edge connector for snap-in-place installation.

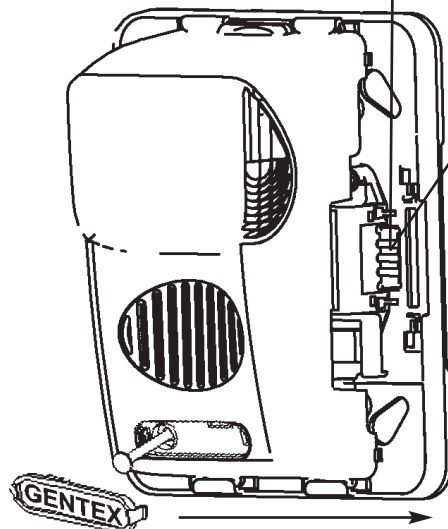

Gentex Checkmate® Instant Voltage Verification

It is often necessary to confirm the voltage drop along a line of devices. The access holes are provided in the back of the terminal block to allow the voltage to be measured directly without removing the device. Typically this would be done at the end of the line to confirm design criteria. Most measurements will be taken using the S+ and S- locations although access is provided to other locations.

NOTE: Care should be taken to not short the test probes.

Candela selection slider switch. Depress center and slide switch to desire brightness level.

Break off pin and insert into hole at the bottom of the selector to lock candela setting. Signal must be removed from bracket and pin pushed forward from backside out of hole to change candela.

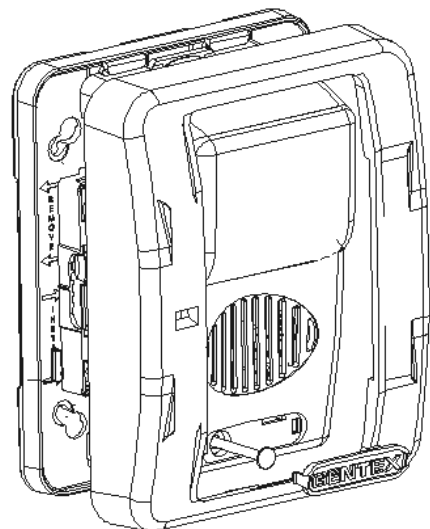
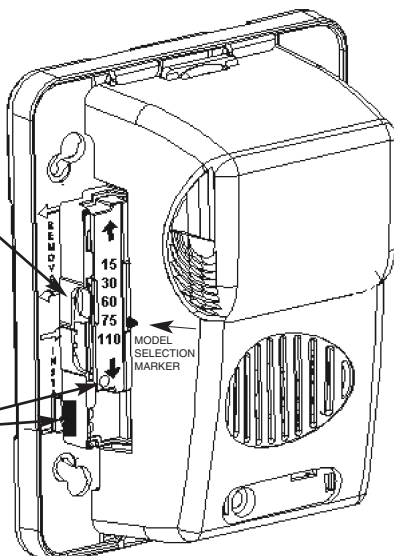

To remove bezel, grip both sides of bezel and pull in a downward and outward motion.

GEC3/GES3 12 & 24 VDC S E R I E S

Conventional Wiring Diagrams for Emergency Notification Evacuation Series

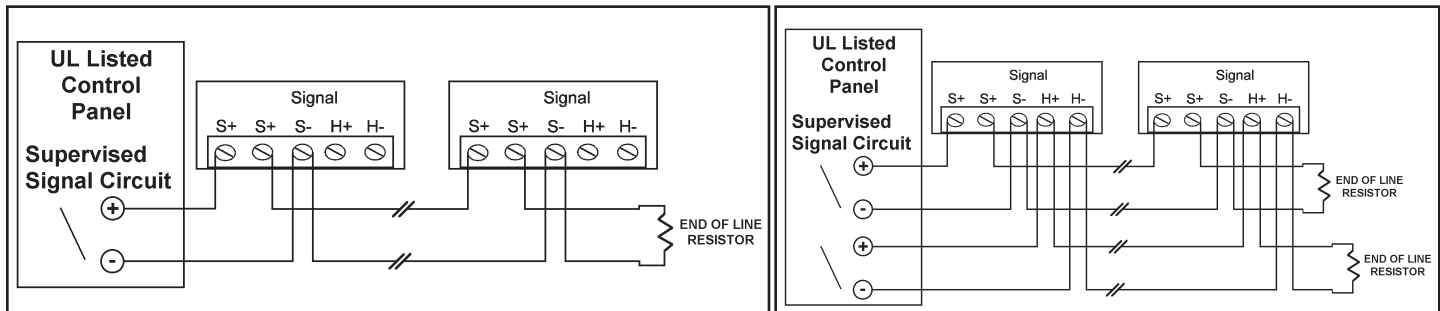

NOTES:

- All strobes are designed to flash as specified with continuous applied voltage. Strobes should not be used on coded or pulsing signaling circuits. However, use of the Gentex AVSM control module or Gentex synchronization protocol is permitted to synchronize the strobe, horn and/or mute the horn. See Technical Bulletin 014 for additional information.
- **FOR SYNCHRONIZATION WIRING INFORMATION, REFERENCE AVSM CONTROL MODULE DATA SHEET (551-0031) AND/OR AVSM CONTROL MODULE MANUAL (550-0284) FOR SYNCHRONIZATION MODULE WIRING DIAGRAMS. AVSM CONTROL MODULE DATA SHEET AND MANUAL CAN BE OBTAINED AT <http://www.gentex.com> OR CALL GENTEX CORPORATION AT 1-800-436-8391.**
- When synchronizing the GE3 12VDC Series, the Gentex AVSM control module or Gentex synchronization protocol **MUST** be used.

Architect & Engineering Specifications

The audible and/or visible signal shall be Gentex GEH, GES3, GEC3 Series or approved equal and shall be listed by Underwriters Laboratories, Inc. per ANSI/UL 1971 and/or ANSI/UL 464. The notification appliance shall also be listed with Factory Mutual Listing Service (FM) and the California State Fire Marshal (CSFM).

The notification appliance (combination audible/visible) shall produce a peak sound output of 100dBA or greater at 12VDC or 24VDC as measured in an anechoic chamber. The signaling appliance shall also have the capability to silence the audible signal while leaving the visible signal energized with the use of a single pair of power wires. Additionally, the user shall be able to select either continuous or temporal tone output with the temporal signal having the ability to be synchronized.

Unit shall be capable of being installed so that any unauthorized attempt to change the candela setting will result in a trouble signal at the fire alarm control panel.

The audible/visible and visible signaling appliance shall also maintain a minimum flash rate of 1Hz or up to 2Hz regardless of power input voltage. The strobe appliance shall have an operating current of 42mA or less at 24VDC for the 15Cd strobe circuit and 92mA or less at 12VDC for the 15Cd strobe circuit.

The appliance shall be polarized to allow for electrical supervision of the system wiring. The unit shall be provided with a mounting bracket with terminals and barriers for input/output wiring and be able to mount to a single gang or double gang box or double workbox without the use of an adapter plate. The unit shall have an input voltage range of 16-33 volts with either direct current or full wave rectified power for 24VDC models or a voltage range of 8-17.5 volts for 12VDC models.

The appliance shall be capable of testing supervision without disconnecting wires, verify voltage without removing unit and be capable of mounting to a surface back box.

24 units per carton
28 pounds per carton

GENTEX CORPORATION

Fire Protection Products Group • www.gentex.com
10985 Chicago Drive • Zeeland, Michigan 49464
616.392.7195 • 1.800.436.8391 • 616.392.4219 Fax

Gentex Corporation reserves the right to make changes to the product data sheet at their discretion.

Important Notice:

These materials have been prepared by Gentex Corporation ("Gentex") for informational purposes only, are necessarily summary, and are not purporting to serve as legal advice and should not be used as such. Gentex makes no representations and warranties, express or implied, that these materials are complete and accurate, up-to-date, or in compliance with all relevant local, state and federal laws, regulations and rules. The materials do not address all legal considerations as there is inevitable uncertainty regarding interpretation of laws, regulations and rules and the application of such laws, regulations and rules to particular fact patterns. Each person's activities can differently affect the obligations that exist under applicable laws, regulations or rules. Therefore, these materials should be used only for informational purposes and should not be used as a substitute for seeking professional legal advice. Gentex will not be responsible for any action or failure to act in reliance upon the information contained in this material.

551-0050-06



Reviewed for Code Compliance
Permitting and Inspections Department
Approved with Conditions

05/13/2020

**NO
EXCUSES!**

SIGNALING



SYSTEM RECORD DOCUMENTS

The SRD is the perfect item to help you meet demanding code requirements today. NFPA 72 2013 7.7.2.4 states that a cabinet must be "prominently labelled 'SYSTEM RECORD DOCUMENTS'."

The SRD is the perfect fit to meet today's demanding code requirements. SAE's number one goal is to manufacture code compliant solutions and this product allows you to do just that. NFPA 72 2013 7.7.2.1 states, "With every new system, a documentation cabinet shall be installed at the system control unit or other approved location at the protected premises."

This durable 16 gauge steel enclosure with a solid piano hinge and key lock will keep all of your code required documents in one safe place. With a 4GB USB flash drive it stores your fire alarm software safe and secure eliminating the occurrences of the software not being on site when technicians arrive to service the system. Along with your fire alarm software you can store your test & inspection, service records, manuals & system records. Using a standard USB B connector you may also store your records electronically (See NFPA 72 2013 7.5.6.7).

The SRD has designated hooks to organize key rings and hold important business cards for easy access and reference. Inside the cover it has an organized record for identifying equipment information, required documentation locations (See NFPA 72 2013 7.2.1).



Reviewed for Code Compliance
Permitting and Inspections Department
Approved with Conditions

05/13/2020

Standard Features:

- Installed with a 4 GB digital flash drive with USB B connector
- 2 key ring hooks to hold system keys
- Business card holder for key contacts
- Overall dimensions are 12" x 13" tall and 2 1/4" deep
- 18 gauge steel box and cover for security
- Durable powder coat baked on finish other colors available
- Standard 3/4" cat 30 key lock. Other lock assemblies available
- Solid stainless steel piano hinge
- Permanently screened white ink 1" high "SYSTEM RECORD DOCUMENTS"
- Legend sheet for documentation, passwords and system information



Made In U.S.A.

**ISO 9001
REGISTERED
COMPANY**

ACEBOX

Space Age Electronics, Inc.
www.1sae.com
800.486.1723 Toll Free
508.485.0966 Local
508.485.4740 Fax



Reviewed for Code Compliance
 Permitting and Inspections Department
 Approved with Conditions
05/13/2020

Specifications:

The system record documents box (SRD) shall be UL Listed, constructed of 18 gauge cold rolled steel. It shall have a red powder coat epoxy finish. The cover shall be permanently screened with 1" high lettering "SYSTEM RECORD DOCUMENTS " with white indelible ink. The access door shall be locked with a 3/4" barrel lock and the hinge shall be a solid width 12" stainless steel piano hinge. The enclosure will supply 4 mounting holes. Inside the enclosure will accommodate standard 8 1/2 x 11 manuals and loose document records that will be protected within the enclosure. A legend sheet will be permanently attached to the door for system required documentation, key contacts and system information. The SRD will have securely mounted inside a minimum of 4 Gigabyte digital flash memory drive with a standard USB B connector for uploading and downloading information. The drive shall not be accessible without tools to any person whom gains access to the records. The enclosure shall also provide 2 key ring holders with a location to mount standard business type cards for key contact personnel.

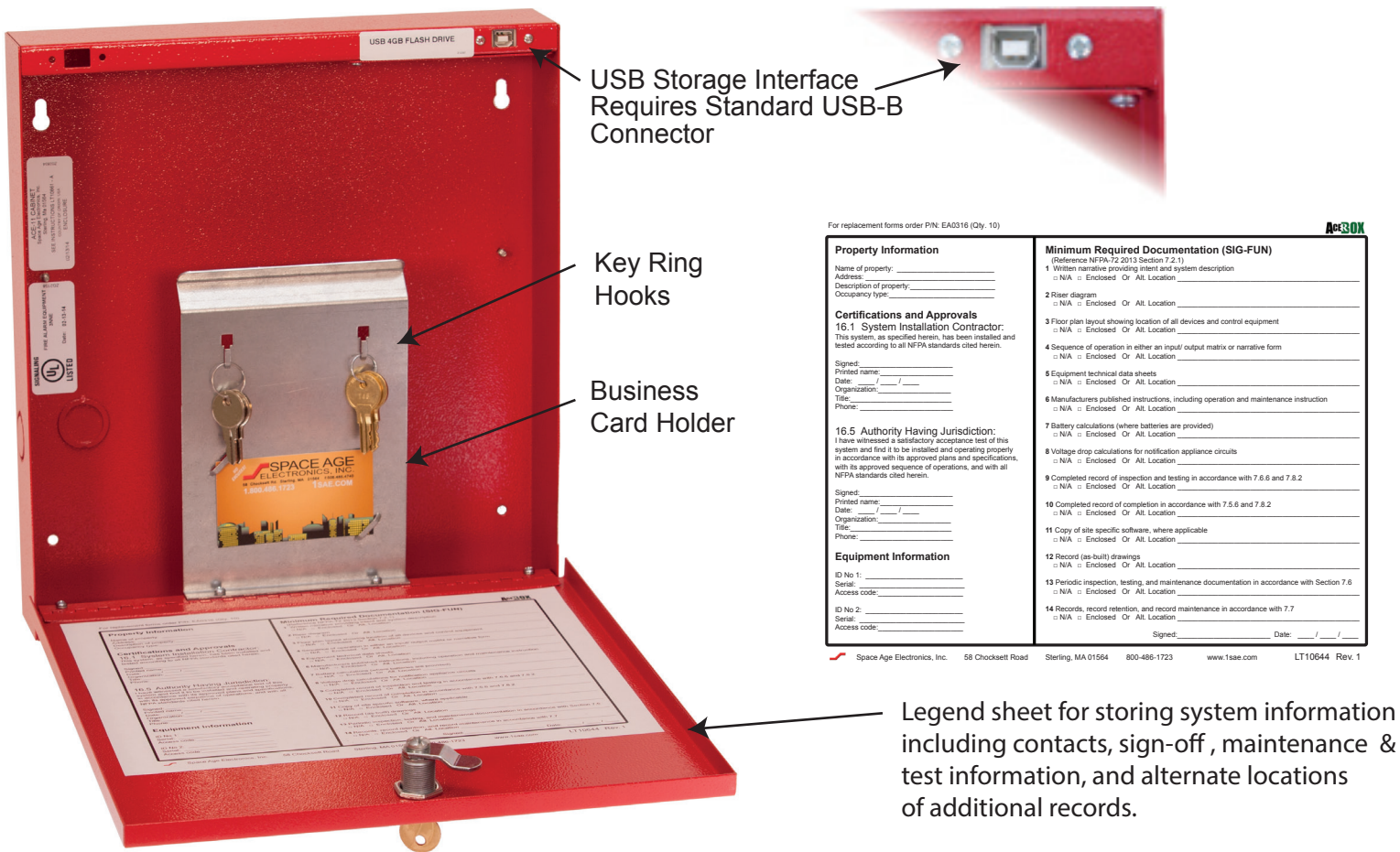

For replacement forms order PIN: EA0316 (Qty. 10)

Property Information	Minimum Required Documentation (SIG-FUN)
Name of property: _____ Address: _____ Description of property: _____ Occupancy type: _____	1 Written narrative providing intent and system description <input type="checkbox"/> N/A <input type="checkbox"/> Enclosed <input type="checkbox"/> All Location
Certifications and Approvals 16.1 System Installation Contractor: This system, as specified herein, has been installed and tested according to all NFPA standards cited herein. Signed: _____ Printed name: _____ Date: ____/____/____ Organization: _____ Title: _____ Phone: _____	2 Riser diagram <input type="checkbox"/> N/A <input type="checkbox"/> Enclosed <input type="checkbox"/> All Location
16.5 Authority Having Jurisdiction: I have witnessed a satisfactory acceptance test of this system and find it to be installed and operating properly in accordance with its approved plans and specifications, with its approved sequence of operations, and with all NFPA standards cited herein. Signed: _____ Printed name: _____ Date: ____/____/____ Organization: _____ Title: _____ Phone: _____	3 Floor plan layout showing location of all devices and control equipment <input type="checkbox"/> N/A <input type="checkbox"/> Enclosed <input type="checkbox"/> All Location
Equipment Information ID No 1: _____ Serial: _____ Access code: _____ ID No 2: _____ Serial: _____ Access code: _____	4 Sequence of operation in either an input/output matrix or narrative form <input type="checkbox"/> N/A <input type="checkbox"/> Enclosed <input type="checkbox"/> All Location
	5 Equipment technical data sheets <input type="checkbox"/> N/A <input type="checkbox"/> Enclosed <input type="checkbox"/> All Location
	6 Manufacturers published instructions, including operation and maintenance instruction <input type="checkbox"/> N/A <input type="checkbox"/> Enclosed <input type="checkbox"/> All Location
	7 Battery calculations (where batteries are provided) <input type="checkbox"/> N/A <input type="checkbox"/> Enclosed <input type="checkbox"/> All Location
	8 Voltage drop calculations for notification appliance circuits <input type="checkbox"/> N/A <input type="checkbox"/> Enclosed <input type="checkbox"/> All Location
	9 Completed record of inspection and testing in accordance with 7.6.6 and 7.8.2 <input type="checkbox"/> N/A <input type="checkbox"/> Enclosed <input type="checkbox"/> All Location
	10 Completed record of completion in accordance with 7.5.6 and 7.8.2 <input type="checkbox"/> N/A <input type="checkbox"/> Enclosed <input type="checkbox"/> All Location
	11 Copy of site specific software, where applicable <input type="checkbox"/> N/A <input type="checkbox"/> Enclosed <input type="checkbox"/> All Location
	12 Record (as-built) drawings <input type="checkbox"/> N/A <input type="checkbox"/> Enclosed <input type="checkbox"/> All Location
	13 Periodic inspection, testing, and maintenance documentation in accordance with Section 7.6 <input type="checkbox"/> N/A <input type="checkbox"/> Enclosed <input type="checkbox"/> All Location
	14 Records, record retention, and record maintenance in accordance with 7.7 <input type="checkbox"/> N/A <input type="checkbox"/> Enclosed <input type="checkbox"/> All Location
	Signed: _____ Date: ____/____/____

Space Age Electronics, Inc. 58 Chocsett Road Sterling, MA 01564 800-486-1723 www.1sae.com LT10644 Rev. 1

Ordering Information:

Part #	Description
SSU00689	System Record Documents Cabinet RED
SSU00690	Custom screening with your Logo
EA0315	10 pack door legend sheet



Space Age Electronics, Inc.
 www.1sae.com
 800.486.1723 Toll Free
 508.485.0966 Local
 508.485.4740 Fax

This document is subject to change without notice, see doc # ED0479 for legal disclaimer

7788F/7744F Series

Wireless Fire Alarm Communicators for AES-IntelliNet



Reviewed for Code Compliance
Permitting and Inspections Department
Approved with Conditions
05/13/2020

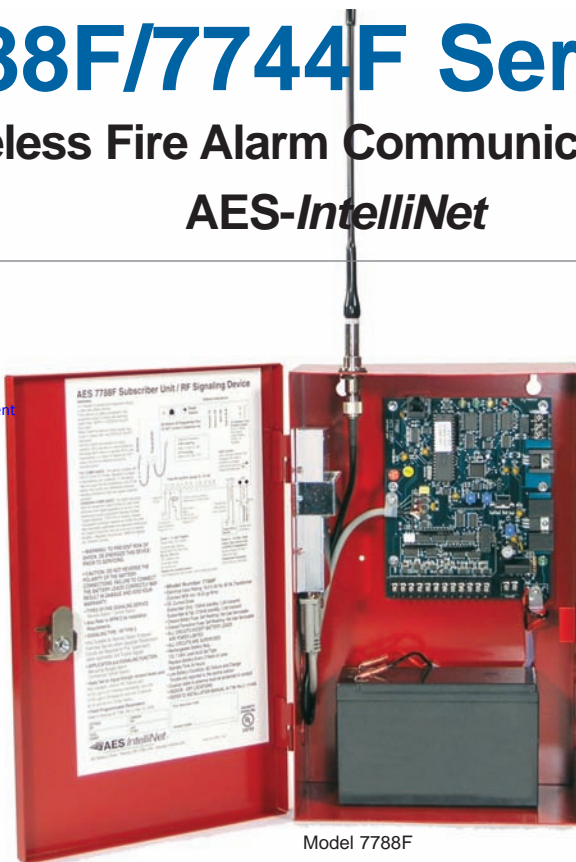

Advanced Wireless Alarm Monitoring

The AES-IntelliNet mesh radio network offers unmatched reliability and speed in delivering wireless alarm signals to a central station without third party fees or reliance on networks owned by companies outside the security and fire alarm industry. AES-7788F/7744F Series Smart Subscriber Transceivers provide the wireless communication link between the fire alarm panel and the central station receiver. The 7788F/7744F Series is ideal for most commercial fire alarm applications. Each 7788F/7744F Series Subscriber is housed in a full sized, red, locked, steel cabinet and supports a range of alarm panel inputs including EOL fire, EOL supervised, and direct voltage from the panel (non-fire applications).

Supervised Operation

AES Smart Subscribers offer fully supervised operation that includes monitoring of operating power (both primary AC power and battery backup) and the connection to the radio network. Each Subscriber "checks in" with the AES central station receiver at least once every 24 hours. The supervision check in time can be set for as often as once per minute and, because the central station owns the wireless network, there is no additional cost for air time to transmit supervisory signals.

Full Data Reporting from Alarm Panel Digital Dialer

Models 7788F-ULP and 7744F-ULP come equipped with an IntelliPro Fire Full Data Module (AES-7794) which enables reporting of full alarm data captured from the fire alarm panel's digital communicator. IntelliPro Fire supports most alarm communication formats including Contact ID, Pulse, as well as Bosch Modem IIe and Modem IIIa2.

Features – All models

- UL Listed commercial fire alarm applications.
- Meets NFPA 72 requirements
- Direct reporting to AES receiver across IntelliNet wireless mesh network
- Each Subscriber acts as transmitter/receiver/repeater
- Simple and fast activation on network
- On board status LEDs for easy set up
- 8 programmable zone inputs – 7788F
- 4 programmable zone inputs and 4 reverse polarity inputs – 7744F
- Easy programming via AES handheld programmer or PC
- Rugged metal housing ideal for any commercial fire alarm application

Models 7788F/7744F-ULP with IntelliPro Fire also includes

- IntelliPro Fire transmits full alarm data from virtually any fire alarm panel digital communicator
- Alarm format support for Contact ID, Pulse, or Bosch Modem IIe or Modem IIIa2
- Easy installation in AES subscriber
- Operates in applications with or without a phone line



Wireless mesh networking is an innovative technology adopted by many industries with applications that need to communicate data over a large geographic area with a high level of reliability at a low total cost of ownership.

The advanced design and 2-way communications capability provides easy installation, expansion, and management when compared to alternative communication methods, both wired and wireless.

7788F/7744F Series



Technical Specifications

7788F/7744F Series Subscribers

Dimensions

- 13.25"H x 8.5"W x 4.3"D
(34cm H x 21.5cm W x 11cm D)

Weight

- Approx. 7 pounds (3.2 kilograms),
excludes battery.

Radio Frequency

- Standard Frequency Range:
450-470MHz (others available)
- Output Power - 2 Watts
(others available)

Antenna

- Included 2.5 db tamper resistant
antenna mounts on enclosure
- Multiple remote antenna options
available

Power Input

- 16.5VAC, 40VA (transformer not
included)

Backup Battery

- Will charge 12V battery up to 7.5 AH.
Requires 12VDC 7.5 AH battery for
UL 864.

Alarm Signal Inputs (subscriber)

- 7788F – 8 individually programmable
zones
- 7744F - 4 individually programmable
zones and 4 reverse polarity inputs

UL Standards

- UL 864 Edition 9 – Standard for
Control Units and Accessories for Fire
Alarm Systems
- UL 365 – Standard for Police Station
Connected Burglar Alarm Units and
Systems
- UL 1681 – Standard for Central
Station Burglar Alarm Units

Antenna Cut / Communication

Trouble Output

- Form C relay; fail secure; rated for 24
VDC 1A resistive

Reset Button

- Located on main circuit board.

Operating Temperature

- 0° to 50° C (32° to 122°F)

Storage Temperature

- -10° to 60° C (14° to 140°F)

Relative Humidity

- 0 to 85% RHC, Non Condensing

AES-7794 IntelliPro Fire

Input / Output Connections

- RJ11 connection to AES subscriber for
module data and power
- RJ11 connector for Handheld
Programmer/PC programming
- RJ31X Telco connections - T and R
both in and out via terminal strip and
RJ45
- Alarm Panel digital communicator
T and R both in and out via terminal
strip and RJ45
- Trouble output: Form C relay detects if
Subscriber is off the network

Alarm Formats

- Support for Contact ID and Pulse
formats as well as Modem IIe and
Modem IIIa2 converted to CID

Size

- 2.8 x 5.0 inches (7.1cm x 12.7cm)

Power Requirements

- 12 VDC nominal - primary and backup
power provided by the AES
7788F/7744F or other Subscriber

How to Order

Model	Description
7744F	4 Zone Fire Alarm Subscriber with 4 reverse polarity inputs
7744F-ULP	7744F Fire Alarm Subscriber with IntelliPro Fire full data module
7788F	8 Zone Fire Alarm Subscriber
7788F-ULP	7788F Fire Alarm Subscriber with IntelliPro Fire full data module

Optional Accessories

7041E	Subscriber Handheld Programmer
7794	IntelliPro Fire Full Data Module



AES-IntelliNet™ is the industry leader in delivering high quality wireless mesh networks to the fire and security industry in commercial, corporate, government, and educational applications with its broad line of products and advanced network management tools. Users of AES-IntelliNet networks have gained significant revenue, communications, and cost advantages while meeting the high standards of reliability required for the fire and security industry. AES-IntelliNet alarm monitoring systems are deployed at hundreds of thousands of locations in over 150 countries.



For more information

Call 800-AES-NETS (800-237-6387)

AES Corporation | 285 Newbury Street | Peabody, MA 01960 USA

Tel. +1 978-535-7310 | Fax +1 978-535-7313 | Email info@aes-intellinet.com

Web www.aes-intellinet.com



Reviewed for Code Compliance
Permitting and Inspections Department
Approved with Conditions

05/13/2020

Copyright 2011 AES Corporation
AES-IntelliNet is a registered trademark
of AES Corporation

7788F-7744F/9/7/11R3

AC Transformers & 12 VDC Plug In Power Supply

ELK-TRG1640 & TRG2440

- Auto-Resetting (PTC) Fused Secondary
- Green Power On LED
- Grounding Prong & Terminal
- Electrical outlet mounting tab
- UL Listed
- Lifetime Limited Warranty
- Wire Strain Relief

Specifications

- Input Voltage: 120 VAC, 60 Hz, .43A
- Output Voltage: TRG1640 = 16.5 Volts A.C.
TRG2440 = 24 Volts A.C.
- Output Power: TRG1640 = 45 VA
TRG2440 = 40 VA
- Size: 4.14"H x 2.74"W x 2.2"D
(105mm x 70mm x 56mm)
- Color: White

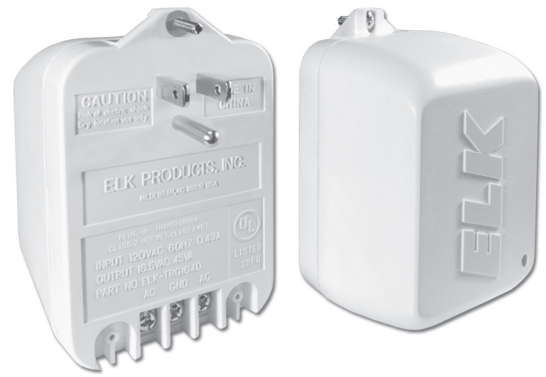

LIFETIME WARRANTY
Grounding Terminal
Power LED
Strain Relief
All in One!

ELK-P1216

The ELK-P1216 is a general purpose 12 Volts D.C. Switching Plug-In Power Supply. It is ideal for alarm, access control, and CCTV applications requiring up to 1.5 Amps. The power pack plugs into 100 to 120 Volts A.C., and supplies regulated 12 Volts D.C. to a standard 2.1mm power plug.

Features

- Switching Power Supply
- Regulated 12 Volts D.C. Output
- Six foot cord and standard
- 2.1mm x 5.5mm x 9mm plug (center is positive)
- UL Listed
- Efficiency Level: V
- Lifetime Limited Warranty

Specifications

- DC Output Voltage: 12 Volts D.C.
- Current Rating: 1.5 Amps
- AC Input Voltage Range: 100-120 @ 47~63 Hz
- Size: 1.75"H x 1.375"W x 2.75"D



12 Volts D.C.
Plug-In Power Supply
Slimline Design
RoHS Compliant



Reviewed for Code Compliance
Permitting and Inspections Department
Approved with Conditions

05/13/2020

Recessed Mount
with Face Flange



Surface Mount

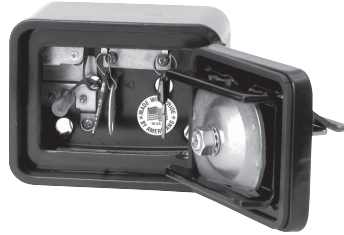

High Security Industrial/Government Key Box



The number one high-security KNOX-BOX® is used for most commercial applications including businesses, schools, government and public buildings, community associations and apartment complexes. The 3200 Series KNOX-BOX holds keys, access cards and other small items necessary for emergency access.

The hinged-door 3200 Series KNOX-BOX is more convenient than the lift-off door version because it allows single-handed operation and opened or closed, it's all one unit.

Features and Benefits

- Holds up to 10 keys and access cards in interior compartment
- Ensures high security. Box and lock are UL® Listed
- Includes a Knox-Coat® proprietary finishing process that protects Knox products up to four times better than standard powder coat
- Resists moist conditions with a weather resistant door gasket
- Hinged door allows single-handed operation
- Colors: Black, Dark Bronze or Aluminum
- Weight: Surface mount - 8 lbs.
Recessed mount - 9 lbs.



Reviewed for Code Compliance
Permitting and Inspections Department
Approved with Conditions

05/13/2020

Options

- Alarm tamper switches (UL Listed)
- Recessed Mounting Kit (RMK) for recessed models only
- Inside switch for use on electrical doors, gates and other electrical equipment

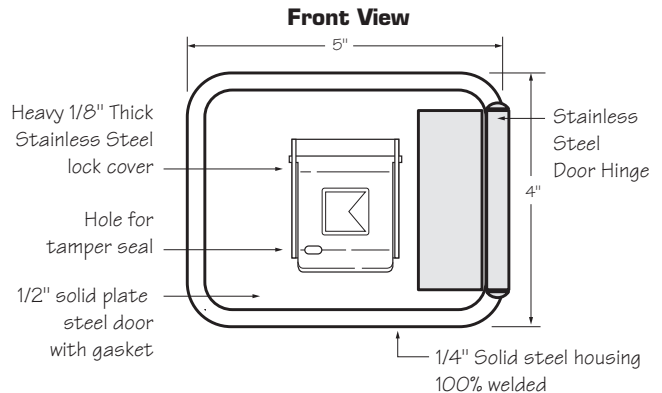

3200 Surface Mount

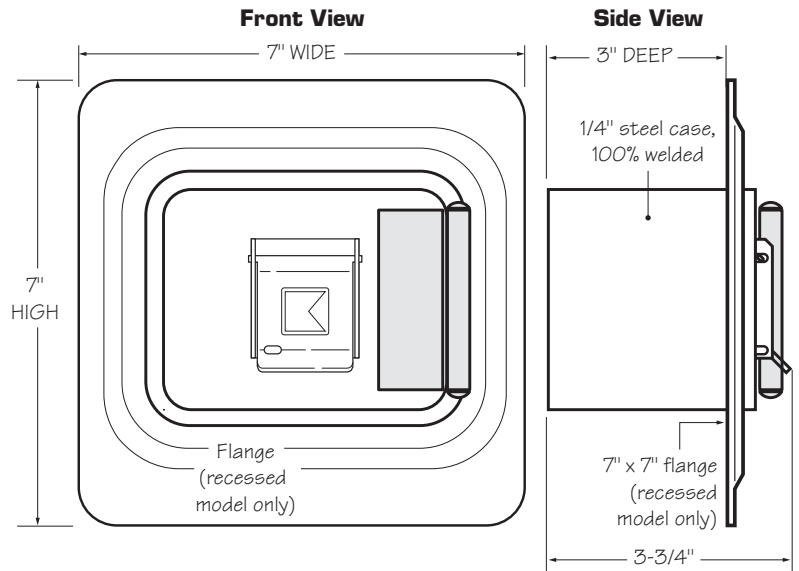

3200 Recessed Mount

Ordering Specifications

To insure procurement and delivery of the 3200 Series KNOX-BOX, it is suggested that the following specification paragraph be used:

KNOX-BOX surface/recessed mount with hinged door, with/without UL Listed tamper switches. 1/4" plate steel housing, 1/2" thick steel door with interior gasket seal and stainless steel door hinge. Box and lock UL Listed. Lock has 1/8" thick stainless steel dust cover with tamper seal mounting capability.

Exterior Dimensions: Surface mount body- 4"H x 5"W x 3-3/4"D
Recessed mount flange- 7"H x 7"W

Lock: UL Listed. Double-action rotating tumblers and hardened steel pins accessed by a biased cut key.

Finish: Knox-Coat® proprietary finishing process

Colors: Black, Dark Bronze or Aluminum

P/N: 3200 Series KNOX-BOX (mfr's cat. ID)

Mfr's Name: **KNOX COMPANY**

**Suggested minimum mounting height
6 feet above ground**

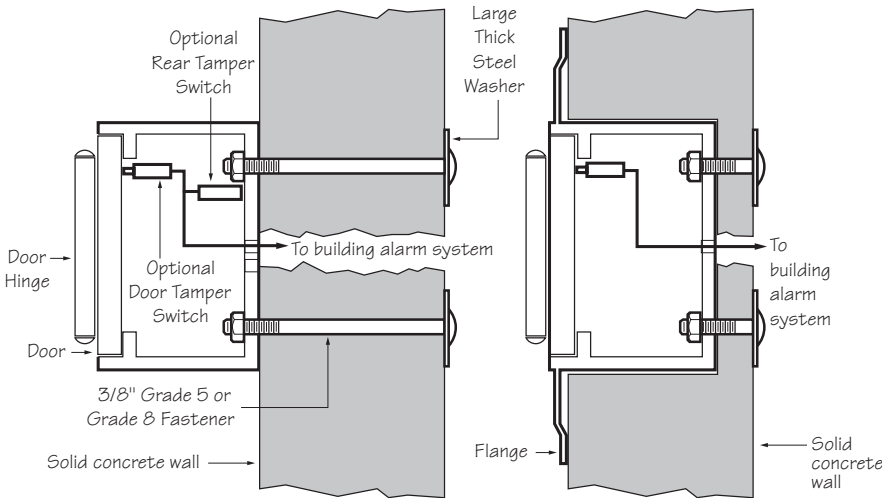

**3200 Series Hinged Door
Surface Mount**

**3200 Series Hinged Door
Recess Mount**



Reviewed for Code Compliance
Permitting and Inspections Department
Approved with Conditions

05/13/2020

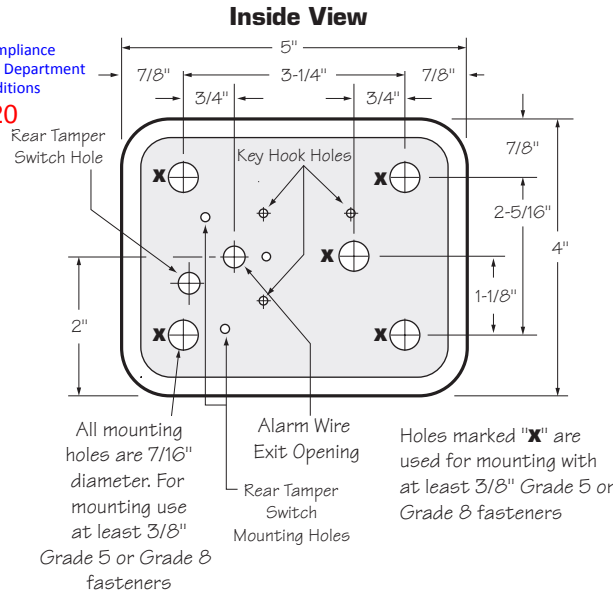

All mounting holes are 7/16" diameter. For mounting use at least 3/8" Grade 5 or Grade 8 fasteners

Holes marked "X" are used for mounting with at least 3/8" Grade 5 or Grade 8 fasteners

Attention: KNOX-BOX[®] is a very strong device that MUST be mounted properly to ensure maximum security and resist physical attack.

Knox[®] Rapid Entry System

The Knox Company manufactures a complete line of high security products including Knox-Box key boxes, key vaults, cabinets, key switches, padlocks, locking FDC caps, plugs and electronic master key security systems. For more information or technical assistance, please call Customer Service at 1-800-552-5669.

Recessed Mounting Kit

The 3200 Recessed Mounting Kit (RMK) is used for recessed models only. It contains a shell housing and mounting hardware to be cast-in-place in new concrete or masonry construction. After construction is completed, the KNOX-BOX mounts inside the RMK. The RMK may only be used in new concrete or masonry construction.

Installation In Cast Concrete

The optional Recessed Mounting Kit is for use in new concrete or masonry construction only. The kit includes a shell housing and mounting hardware to be cast-in-place. The KNOX-BOX is mounted into the shell housing after construction is completed.

Dimensions

Rough-in Dimensions: 6-1/2"H x 6-1/2"W x 5"D

IMPORTANT: Care should be taken to insure that the front of the RMK shell housing, including the cover plate and screw heads, is flush with the finish wall. The RMK must be plumbed to insure vertical alignment of the vault.

Recessed Mounting Using Recessed Mounting Kit (RMK)

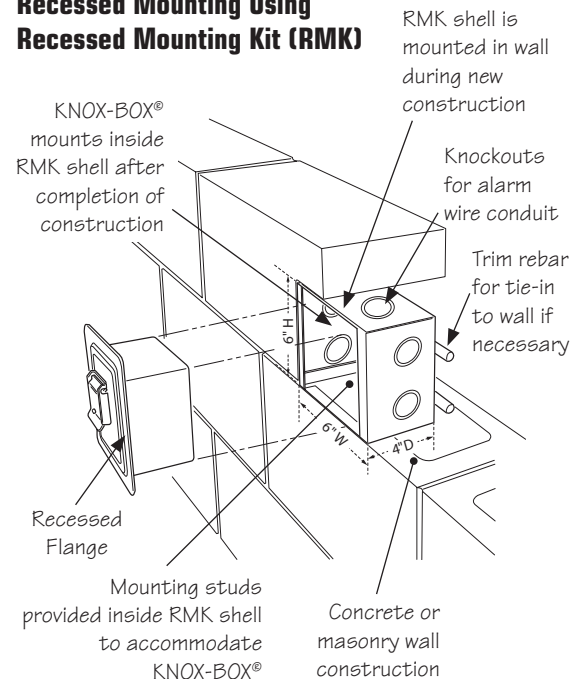

NOTIFICATION APPLIANCE CIRCUIT VOLTAGE DROPS												
Growing Learners												
Portland, Maine												
PANEL	CIRCUIT	WIRE GAUGE	LENGTH	CURRENT DRAW	VOLTAGE DROP		VOLTAGE LOSS	END VOLTAGE @ 24.0VDC		END VOLTAGE @ 20.4VDC		CIRCUIT LOAD
FCPS #1	NAC 1	14	350 FT	0.521A	0.92	VDC	3.84%	23.08	VDC	19.48	VDC	17%
FCPS #1	NAC 2	14	500 FT	0.712A	1.8	VDC	7.49%	22.2	VDC	18.6	VDC	24%
FCPS #1: 1.233A/8A Spare Capacity: 85%												
Calculated @ Maximum Distance/Current												





NFS-320 - AC Branch Current

Select devices using the "Qty" column.
 Use yellow cells to enter quantities and current values.
 To show only selected devices, select "Show Selected Devices".
 To clear selected devices, select "Clear Selections".

Note: These selections only determine the AC branch current. If these devices will affect the battery requirements, you need to select them on the System Current Draw sheet.

120 VAC 220/240 VAC

Device	Qty		Current	Total
CPS-24	1	x	5.00 A	5.00 A
AA-30	0	x	1.00 A	
AA-120	0	x	1.85 A	
ACPS-2406	0	x	2.70 A	
APS-6R	0	x	2.50 A	
AVPS-24	0	x	1.00 A	
CHG-120	0	x	2.00 A	
FCPS-24	0	x	2.00 A	
FCPS-24S6/S8	1	x	3.20 A	3.20 A
MPS-24A	0	x	1.80 A	
MPS-24B	0	x	2.40 A	
XPIQ	0	x	3.50 A	
XRM-24	0	x	1.00 A	
ACPS-610	0	x	5.00 A	
APS2-6R	0	x	2.90 A	
DAA Series	0	x	4.50 A	
HPFF8	0	x	3.60 A	
HPFF12	0	x	5.00 A	
DS-AMP (25V)	0	x	4.10 A	
DS-AMP (70V)	0	x	3.55 A	
NFC-50/100	0	x	3.50 A	
NFC-50DA (25v)	0	x	1.10 A	
NFC-50DA (70.7v)	0	x	1.20 A	
NFC-125DA	0	x	2.20 A	
DAA2-5025	0	x	2.05 A	
DAA2-5070	0	x	2.13 A	
DAA2-7525	0	x	2.82 A	
DAX-5025	0	x	0.50 A	
DAX-5070	0	x	0.55 A	
DAX-3525	0	x	0.50 A	
DAX-3570	0	x	0.55 A	
AES 7788F	1	x	0.43 A	0.43 A
[]	0	x	0.00 A	
AC Branch Required:				8.63 A





System Power Requirements

Notifier NFS-320 Fire Alarm Control Panel

Protected Premises: <u>Growing Learners</u>	Date: <u>4/24/2020</u>
Address: <u>631 Stevens Ave.</u>	
City: <u>Portland</u>	State: <u>Maine</u> Zip: <u>04103</u>
Prepared By: <u>Norris Inc</u>	Phone: <u>1-800-370-3473</u>
Address: <u>2257 West Broadway</u>	Email: jbridges@norrising.com
City: <u>South Portland</u>	State: <u>Maine</u> Zip: <u>04106</u>

AC Branch Current Requirements 8.63 AMPS @ 120 VAC

Current required by source to power the fire alarm system.

Primary Standby Load 0.81 Amps

Current load on the primary power supply during non-alarm conditions.

Primary Alarm Load 1.29 Amps

Current load on the primary power supply during alarm conditions.

Secondary Load Requirements 18.93 Amp Hours

Total Secondary Load from the calculation table below.

Current Draw		Time (hours)	Total (AH)
Secondary Standby Load 0.653 A	x	Required Standby Time	
		24 hours	15.68
Secondary Alarm Load 1.126 A	x	Required Alarm Time (hours)	
		0.084 hours	0.09
Total Secondary Load			15.78
Derating factor			x 1.2
Secondary Load Requirements (Amp Hours)			18.93 AH

Battery Selection 26 Amp Hours

Select batteries from the list below.

26 AH BAT-12260 Battery (12 volt)

- Two
 Four (two 12VDC sets in parallel)



Battery Distribution Chart

Shows amp-hour distribution of your selections.

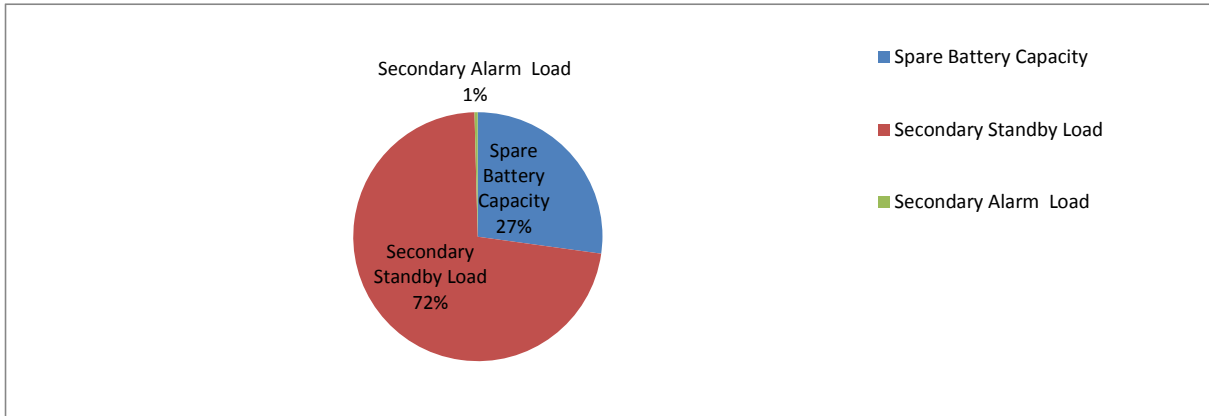

Comments

1. Batteries will fit in the FACP cabinet.
2. Selected battery size meets secondary load requirements.
3. The selected batteries (26AH) are within the charger range of this power supply (18-200AH).

Spare Battery Capacity	7.07	Battery Selection (AH) - Secondary Load Requirements (AH)
Secondary Standby Load	18.82	Secondary Standby Load (AH) * Derating Factor
Secondary Alarm Load	0.11	Secondary Alarm Load (AH) * Derating Factor





System Power Requirements

FCPS-24s8 Power Supply

Protected Premises: <u>Growing Learners</u>	Date: <u>4/24/2020</u>
Address: <u>631 Stevens Ave.</u>	
City: <u>Portland</u> State: <u>Maine</u>	Zip: <u>04103</u>
Prepared By: <u>Norris Inc.</u>	Phone: <u>1-800-370-3473</u>
Address: <u>2257 West Broadway</u>	Email: <u>jbridges@norrisinc.com</u>
City: <u>South Portland</u> State: <u>Maine</u>	Zip: <u>04106</u>

AC Branch Current Requirements 3.20 AMPS @ 120 VAC

Current required by source to power the fire alarm system.

Primary Standby Load 0.10 Amps

Current load on the primary power supply during **non-alarm** conditions.

Primary Alarm Load 1.73 Amps

Current load on the primary power supply during **alarm** conditions.

Secondary Load Requirements 2.25 Amp Hours

Total Secondary Load from the calculation table below.

Current Draw		Time (hours)	Total (AH)
Secondary Standby Load 0.072 A	x	Required Standby Time	
		24 hours	1.73
Secondary Alarm Load 1.728 A	x	Required Alarm Time (hours)	
		0.084 hours	0.15
Total Secondary Load			1.87
Derating factor			x 1.2
Secondary Load Requirements			2.25

AH

Battery Selection 7 Amp Hours

Select batteries from the list below.

7 AH BAT-1270 Battery (12 volt)

- Two
- Four (two 12VDC sets in parallel)



Battery Distribution Chart

Shows amp-hour distribution of your selections.

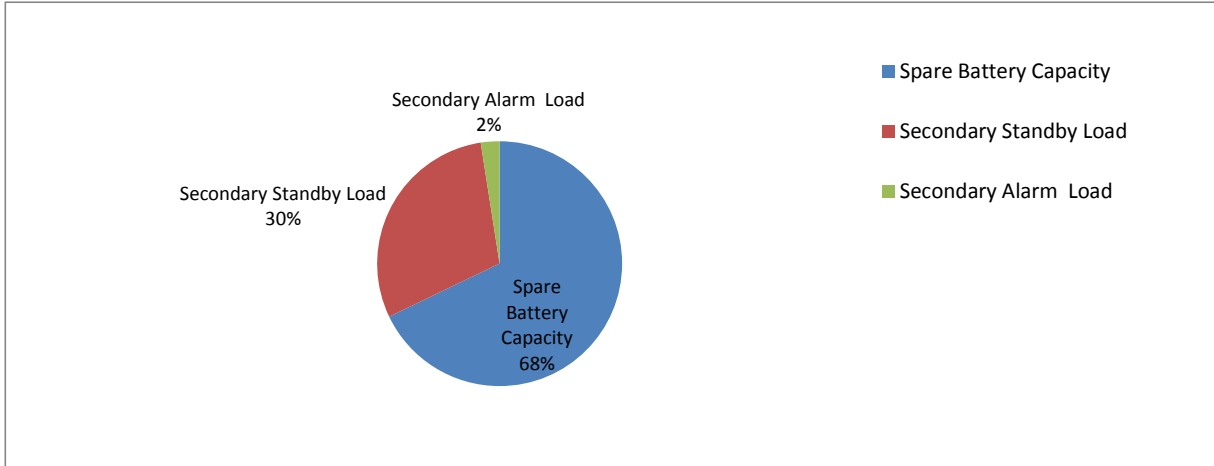

Comments

1. Batteries will fit in the FACP cabinet.
2. Selected battery size meets secondary load requirements.
3. The selected batteries (7AH) are within the charger range of this power supply (7-18AH).

Spare Battery Capacity	4.75	Battery Selection (AH) - Secondary Load Requirements (AH)
Secondary Standby Load	2.07	Secondary Standby Load (AH) * Derating Factor
Secondary Alarm Load	0.17	Secondary Alarm Load (AH) * Derating Factor





Reviewed for Code Compliance
Permitting and Inspections Department
Approved with Conditions
05/13/2020

FIRE ALARM MATRIX

SYSTEM INPUTS	SYSTEM OUTPUTS															
	A	B	C	D	E	F	G	H	I	J	K	L	M	N	O	P
1 MANUAL FIRE ALARM PULL STATION																
2 AREA SMOKE DETECTOR																
3 AREA HEAT DETECTOR																
4 CARBON MONOXIDE DETECTOR																
5 SPRINKLER WATERFLOW - BUILDING																
6 SPRINKLER TAMPER VALVE SUPERVISORY SWITCH																
7 KITCHEN HOOD																
8 FIRE ALARM AC POWER FAILURE																
9 FIRE ALARM SYSTEM LOW BATTERY																
10 OPEN CIRCUIT																
11 GROUND FAULT																
12 NOTIFICATION APPLIANCE CIRCUIT SHORT																

SYMBOL LEGEND

DEVICES	NOTIFICATION
PULL STATION	HORN STROBE
SMOKE DETECTOR	STROBE
HEAT DETECTOR	XX = CANDELA RATING
SMOKE/CO COMBO DETECTOR (SB=SOUNDER BASE)	
MONITOR MODULE (M=MINI, D=DUAL)	
RELAY MODULE	
ANSUL MICRO SWITCH F.B.O.	
SPRINKLER SWITCH F.B.O.	

WIRE LEGEND

- 2 COND 16 AWG TWISTED PAIR FPL(R)(P) CABLE
- 2 COND 14 AWG FPL(R)(P) CABLE
- 2 COND 18 AWG FPL(R)(P) CABLE
- 2 COND 18 AWG TWISTED SHIELDED FPL(R)(P) CABLE
- CAT-6 CABLE

DEVICE ADDRESSES:

EACH DEVICE MUST BE LABELED WITH THE NODE, LOOP AND SLC ADDRESS.
DEVICE EXAMPLE: N1L1D001 MODULE EXAMPLE: N1L1M001
CARBON MONOXIDE DETECTORS MUST BE LABELED WITH THE MANUFACTURERS REPLACEMENT DATE. IMPORTANT! DUPLICATE ADDRESSES BETWEEN DEVICES AND MODULES ARE NOT AN ERROR. NOTE: PULL STATIONS ARE IDENTIFIED AS MODULES BY THE FIRE ALARM CONTROL PANEL.

INSTALLATION NOTES:

ALL FIELD WIRING SHALL BE INSTALLED IN CONDUIT.
FIELD WIRING SHALL BE INSTALLED FOLLOWING THE CURRENT EDITION OF NFPA 70: NATIONAL ELECTRIC CODE(2017), ALL APPLICABLE MUNICIPAL, COUNTY, & STATE CODES, REQUIREMENTS, AND REGULATIONS, AS WELL AS ALL MANUFACTURER GUIDELINES FOR INSTALLATION.
CONTROL PANELS, DEVICES, AND ALL OTHER SYSTEM COMPONENTS SHALL BE INSTALLED FOLLOWING THE CURRENT EDITION OF NFPA 72: NATIONAL FIRE ALARM AND SIGNALING CODE(2019), ALL APPLICABLE MUNICIPAL, COUNTY, & STATE CODES, REQUIREMENTS, AND REGULATIONS, AS WELL AS ALL MANUFACTURER GUIDELINES FOR INSTALLATION.
THE INSTALLER SHALL FOLLOW CORRECT CONDUCTOR POLARITY, INDICATED CIRCUIT DIVISIONS, PROPER GROUNDING AND SHIELDING WITHOUT EXCEPTION. IMPROPER INSTALLATION CAN RESULT IN INTERFERENCE, TRANSIENT VOLTAGE, OR SHORT CIRCUITS CAUSING UNDESIRABLE OPERATION OR DAMAGE TO THE CONTROL PANEL, DEVICES AND ANY OTHER INTEGRATED COMPONENTS.
IF EXCEEDING 4500 FEET, THE GAUGE OF WIRE USED FOR THE SLC LOOP (IDENTIFIED AS "A" ON THIS PRINT), SHALL BE DETERMINED BY THE INSTALLER FOLLOWING GUIDELINES AND LIMITATIONS SET FORTH BY THE MANUFACTURER (NOTIFIER DOCUMENT #51253, INTELLIGENT CONTROL PANEL SLC WIRING MANUAL). THE SLC WIRING RISER IS SHOWN DIAGRAMMATICALLY ONLY TO ALLOW FOR VARIANCES IN ACTUAL WIRE DISTANCE, DEVICE PLACEMENT AND STRUCTURAL OR ENVIRONMENTAL REQUIREMENTS.
WIRE FOR THE NOTIFICATION APPLIANCE CIRCUITS (IDENTIFIED AS "B" ON THIS PRINT), SHALL FOLLOW THE SPECIFIC REQUIREMENTS OF THE WIRING LEGEND.
THIS SYSTEM MEETS NFPA REQUIREMENTS FOR OPERATION AT 32-120°F AND A RELATIVE HUMIDITY OF 91-95% AT 87-93°F. HOWEVER, THE USEFUL LIFE OF THE SYSTEMS STANDBY BATTERIES AND THE ELECTRONIC COMPONENTS MAY BE ADVERSELY AFFECTED BY EXTREME TEMPERATURE RANGES AND HUMIDITY. THEREFORE, IT IS RECOMMENDED THAT THIS SYSTEM AND ITS PERIPHERALS BE INSTALLED IN AN ENVIRONMENT WITH A NORMAL ROOM TEMPERATURE OF 60-80°F.

DESIGN NOTES:

SYSTEM DESIGN PERFORMANCE AND COMPLIANCE WITH ALL APPLICABLE CODES AND REQUIREMENTS IS THE RESPONSIBILITY OF THE DESIGNING ENGINEER. PROPER INSTALLATION OF THIS SYSTEM AND ITS COMPONENTS IS THE RESPONSIBILITY OF THE INSTALLER CONTRACTOR. ANY ALTERATIONS, CHANGES, OR DEFICIENCIES MUST BE BROUGHT TO THE ATTENTION OF THE DESIGNING ENGINEER.
NORRIS INC. ASSUMES NO RESPONSIBILITY FOR ERRORS IN SYSTEM DESIGN OR INSTALLATION, AS WELL AS ANY COSTS ASSOCIATED WITH CORRECTING THESE ERRORS, IF ANY EXIST, UNLESS SYSTEM DESIGN OR INSTALLATION WAS PERFORMED BY NORRIS INC.

RELAY & MONITOR MODULES:

CONNECTIONS FROM THE RELAY, AND MONITOR MODULES TO THE CONTROL EQUIPMENT, ALONG WITH ANY REQUIRED COMPONENTS SHALL BE FURNISHED BY THE INSTALLER.

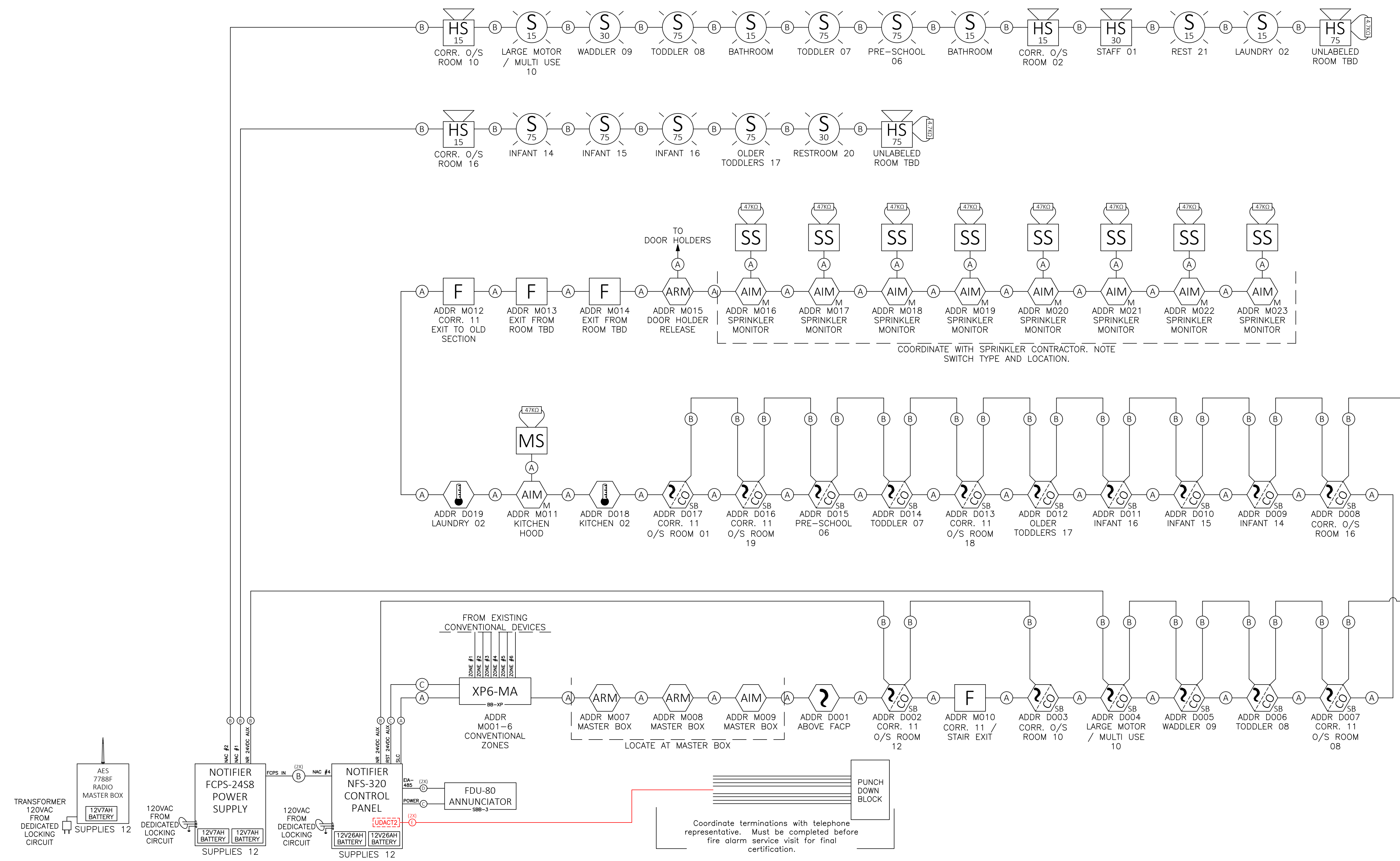

REVISION 0: SUBMITTAL 04/24/2020
FIRE ALARM WIRING RISER
 PROJECT NUMBER: 1704 SCALE: NONE
 PROJECT: GROWING LEARNERS 631 STEVENS AVE. PORTLAND, ME 04103
 DRAWN BY: JAB
 CHECKED BY: MP
 SHEET: FA-01

Norris Inc.
 2257 BROADWAY SOUTH PORTLAND, MAINE