

DISPLAY THIS CARD ON PRINCIPAL FRONTAGE OF WORK CITY OF PORTLAND

Please Read Application And Notes, If Any, Attached

PERMIT ISSUED
JUN 29 2005
Permit Number: 050826
CITY OF PORTLAND

BUILDING DEPARTMENT

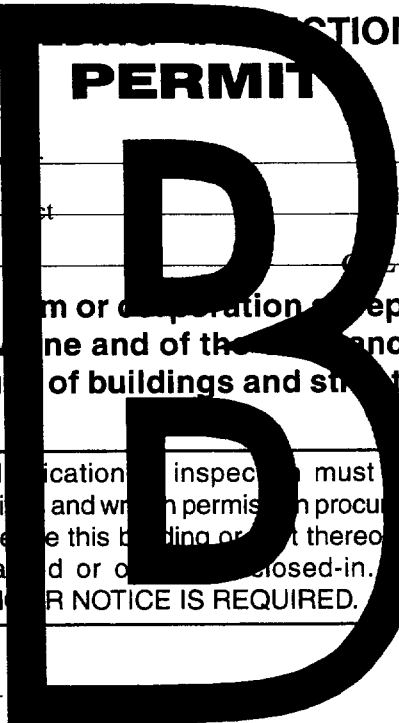

This is to certify that Del Camp Anne C /Home own
has permission to add deck and stairs After the
AT 269 Walton St Call 143 A046001

provided that the person or persons, firm or corporation accepting this permit shall comply with all of the provisions of the Statutes of Maine and of the ordinances of the City of Portland regulating the construction, maintenance and use of buildings and structures, and of the application on file in this department.

Apply to Public Works for street line and grade if nature of work requires such information.

Notification of inspection must be given and written permission procured before this building or part thereof is laid or occupied. **HEAVY NOTICE IS REQUIRED.**

A certificate of occupancy must be procured by owner before this building or part thereof is occupied.

OTHER REQUIRED APPROVALS

Fire Dept. _____
Health Dept. _____
Appeal Board _____
Other _____

Department Name

[Signature] 6/23/05
Director - Building & Inspection Services

PENALTY FOR REMOVING THIS CARD

City of Portland, Maine - Building or Use Permit Application

389 Congress Street, 04101 Tel: (207) 874-8703, Fax: (207) 874-8716

Permit No: 05-0826	Issue Date: JUN 29 2005	City: 143 AC46001
-----------------------	-----------------------------------	----------------------

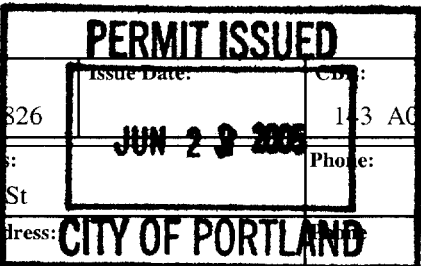

Location of Construction: 269 Walton St	Owner Name: Del Camp Anne C	Owner Address: 271 Walton St	Phone:
Business Name:	Contractor Name: Home owner	Contractor Address: Portland	
Lessee/Buyer's Name	Phone:	Permit Type: Alterations - Commercial	Zone:

Past Use: 2 unit residential	Proposed Use: 2 unit residential add deck and stairs After the Fact	Permit Fee: \$30.00	Cost of Work: \$1,000.00	CEO District: 4
--	---	-------------------------------	------------------------------------	---------------------------

FIRE DEPT: <input type="checkbox"/> Approved <input type="checkbox"/> Denied	INSPECTION: Use Group <i>33</i> Type <i>SS</i> <i>6/23/05</i> <i>[Signature]</i>
---	--

Proposed Project Description:
add deck and stairs After the Fact

Signature _____ **Signature:** *[Signature]*

PEDESTRIAN ACTIVITIES DISTRICT (P.A.D.)

Action: Approved Approved w/Conditions Denied

Signature: _____ Date: _____

Permit Taken By: dmartin	Date Applied For: 06/23/2005	Zoning Approval	
------------------------------------	--	------------------------	--

<p align="center">Special Zone or Reviews</p> <input type="checkbox"/> Shoreland <input type="checkbox"/> Wetland <input type="checkbox"/> Flood Zone <input type="checkbox"/> Subdivision <input type="checkbox"/> Site Plan Maj <input type="checkbox"/> Minor <input type="checkbox"/> MM <input type="checkbox"/> Date: _____	<p align="center">Zoning Appeal</p> <input type="checkbox"/> Variance <input type="checkbox"/> Miscellaneous <input type="checkbox"/> Conditional Use <input type="checkbox"/> Interpretation <input type="checkbox"/> Approved <input type="checkbox"/> Denied Date: _____	<p align="center">Historic Preservation</p> <input type="checkbox"/> Not in District or Landmark <input type="checkbox"/> Does Not Require Review <input type="checkbox"/> Requires Review <input type="checkbox"/> Approved <input type="checkbox"/> Approved w/Conditions <input type="checkbox"/> Denied Date: _____
---	--	---

CERTIFICATION

I hereby certify that I am the owner of record of the named property, or that the proposed work is authorized by the owner of record and that I have been authorized by the owner to make this application as his authorized agent and I agree to conform to all applicable laws of this jurisdiction. In addition, if a permit for work described in the application is issued, I certify that the code official's authorized representative shall have the authority to enter all areas covered by such permit at any reasonable hour to enforce the provision of the code(s) applicable to such permit.

SIGNATURE OF APPLICANT ADDRESS DATE PHONE

RESPONSIBLE PERSON IN CHARGE OF WORK, TITLE DATE PHONE

All Purpose Building Permit Application

If you or the property owner owes real estate or personal property taxes or user charges on any property within the City, payment arrangements must be made before permits of any kind are accepted.

Location/Address of Construction: <u>269-271 Watten St</u>		
Total Square Footage of Proposed Structure		Square Footage of Lot
Tax Assessor's Chart, Block & Lot Chart# Block# Lot# <u>143 A 046</u>	Owner: <u>Del Camp, Anne</u>	Telephone: <u>W-883-1530</u> <u>C-653-3120</u>
Lessee/Buyer's Name (If Applicable)	Applicant name, address & telephone:	cost Of Work: \$ <u>1,000.00</u> Fee: \$ <u>30.00</u>
If the location is currently vacant, what was prior use: <u>2 unit residential</u> Approximately how long has it been vacant: _____ Proposed use: <u>Deck & Stairs</u> Project description: _____		<div style="border: 2px solid black; padding: 5px; width: fit-content; margin: auto;"> <p>CITY OF PORTLAND, ME</p> <p style="font-size: 1.2em;">. N 7 3 2005</p> <p style="font-size: 1.5em; font-weight: bold; margin: 0;">RECEIVED</p> </div>
Mailing address: <u>[Signature]</u>		
We will contact you by phone when the permit is ready. You must come in and pick up the permit and review the requirements before starting any work, with a Plan Reviewer. A stop work order will be issued and a \$100.00 fee if any work starts before the permit is picked up, PHONE: _____		

IF THE REQUIRED INFORMATION IS NOT INCLUDED IN THE SUBMISSIONS THE PERMIT WILL BE AUTOMATICALLY DENIED AT THE DISCRETION OF THE BUILDING/PLANNING DEPARTMENT, WE MAY REQUIRE ADDITIONAL INFORMATION IN ORDER TO APPROVE THIS PERMIT.

I hereby certify that I am the Owner of record of the named property, or that the owner of record authorizes the proposed work and that I have been authorized by the owner to make this application as his/her authorized agent. I agree to conform to all applicable laws of this jurisdiction. In addition, if a permit for work described in this application is issued, I certify that the Code Official's authorized representative shall have the authority to enter all areas covered by this permit at any reasonable hour to enforce the provisions of the codes applicable to this permit.

Signature of applicant: <u>[Signature]</u>	Date: <u>6/23/05</u>
--	----------------------

This is NOT a permit, you may not commence ANY work until the permit is issued.
 If you are in a Historic District you may be subject to additional permitting and fees with the Planning Department on the 4th floor of City Hall

City of Portland, Maine - Building or Use Permit

389 Congress Street, 04101 Tel: (207) 874-8703, Fax: (207) 874-8716

Permit No: 05-0826	Date Applied For: 06/23/2005	CBL: 143 A046001
------------------------------	--	----------------------------

Location of Construction: 269 Walton St	Owner Name: Del Camp Anne C	Owner Address: 271 Walton St	Phone:
Business Name:	Contractor Name: Home owner	Contractor Address: Portland	Phone
Lessee/Buyer's Name	Phone:	Permit Type: Alterations - Commercial	

Proposed Use: 2 unit residential add deck and stairs After the Fact	Proposed Project Description: add deck and stairs After the Fact
---	--

Dept: Zoning **Status:** Approved with Conditions **Reviewer:** Mike Nugent **Approval Date:** 06/22/2005

Note: **Ok to Issue:**

- 1) Based on the information provided by the applicant and field observations from Arthur Rowe, C.E.O., The Deck complies with the required front yard setback and the stair setback encroachment is allowed pursuant to Section 14-425 of the Zoning Ordinance.

Dept: Building **Status:** Approved with Conditions **Reviewer:** Mike Nugent **Approval Date:** 06/23/2005

Note: **Ok to Issue:**

- 1) This permit does not imply building code compliance as the structure was Erected without benefit of a permit and elements of construction are not visible at this time.

FOR MORTGAGE LENDER USE ONLY

GENERAL NOTE: THIS INSPECTION WAS CONDUCTED IN ACCORDANCE WITH THE REQUIREMENTS SHOWN BELOW. (1) THE PURPOSE OF THIS INSPECTION IS TO DETERMINE THE ACCURACY OF THE RECORDS AS SHOWN ON THE PLAN AND TO DETERMINE THE COMPLIANCE WITH RESPECT TO THE CONSTRUCTION OF THE BUILDING AND ACCESSORY STRUCTURE'S COMPLIANCE WITH RESPECT TO THE REQUIREMENTS OF THE BUILDING DEPARTMENT. (2) THIS INSPECTION IS NOT A GUARANTEE OF THE ACCURACY OF THE RECORDS OR THE COMPLIANCE OF THE BUILDING AND ACCESSORY STRUCTURE'S COMPLIANCE WITH RESPECT TO THE REQUIREMENTS OF THE BUILDING DEPARTMENT. (3) THIS INSPECTION IS NOT A GUARANTEE OF THE ACCURACY OF THE RECORDS OR THE COMPLIANCE OF THE BUILDING AND ACCESSORY STRUCTURE'S COMPLIANCE WITH RESPECT TO THE REQUIREMENTS OF THE BUILDING DEPARTMENT. (4) THIS INSPECTION IS NOT A GUARANTEE OF THE ACCURACY OF THE RECORDS OR THE COMPLIANCE OF THE BUILDING AND ACCESSORY STRUCTURE'S COMPLIANCE WITH RESPECT TO THE REQUIREMENTS OF THE BUILDING DEPARTMENT.

TYPE: CONSTRUCTION TO BE USED FOR CONSTRUCTION PURPOSES
 ADDRESS: 205-23 DEXTER STREET INSPECTION DATE: JUNE 14, 2005
LINE 22-5 PL 111.5 SCALE: 1" = 20'



1" = 40'

DEPT. OF BUILDING INSPECTION
 CITY OF PORTLAND, ME
 JUN 23 2005
 RECEIVED

INSPECTION BY SHE

APPLICANT: REBECCA WOODHULL JR. LLC FOR PARTY: NEW ENGLAND TITLE, LLC
 OFFICE: 205-23 DEXTER STREET APPROXIMATE: _____
 LENDER: WELLS FARGO BANK, N.A. FIELD NO: 20512390 FIELD BOOK: _____

YOUR FILE #: 405-551

NADEAU & LODGE, INC.
 PROFESSIONAL LAND SURVEYORS
 500 BRIDGEWAY AVENUE
 PORTLAND, ME 04102
 (207) 378-7800
 320 ELDER WOODS ROAD
 LISIEN, ME 04002
 (207) 469-8880

[Handwritten Signature]
 6-16-05

TYPE: CONSTRUCTION
 DEPT: 205-23 DEXTER STREET
 PLAN: LINE 22-5 PL 111.5
 COUNTY: WALDOBOROUGH
 MUNICIPAL: WALDOBOROUGH
 MAP: LINE 22-5 PL 111.5
 THIS INSPECTION WAS CONDUCTED WITHIN A SPECIAL FLOOD HAZARD ZONE AND THE INSPECTOR HAS DETERMINED THAT THE BUILDING AND ACCESSORY STRUCTURE'S COMPLIANCE WITH RESPECT TO THE REQUIREMENTS OF THE BUILDING DEPARTMENT IS AS FOLLOWS:
 SITE: 205-23 DEXTER STREET
 MUNICIPAL: WALDOBOROUGH
 THE: INSPECTION
 COMPLETION: _____

THIS INSPECTION IS VALID ONLY WITH AN EMBOSSED SEAL AND IS NULL & VOID 90 DAYS AFTER INSPECTION DATE.

THIS INSPECTION IS NOT FOR RECORDING - NOT FOR RECORDING

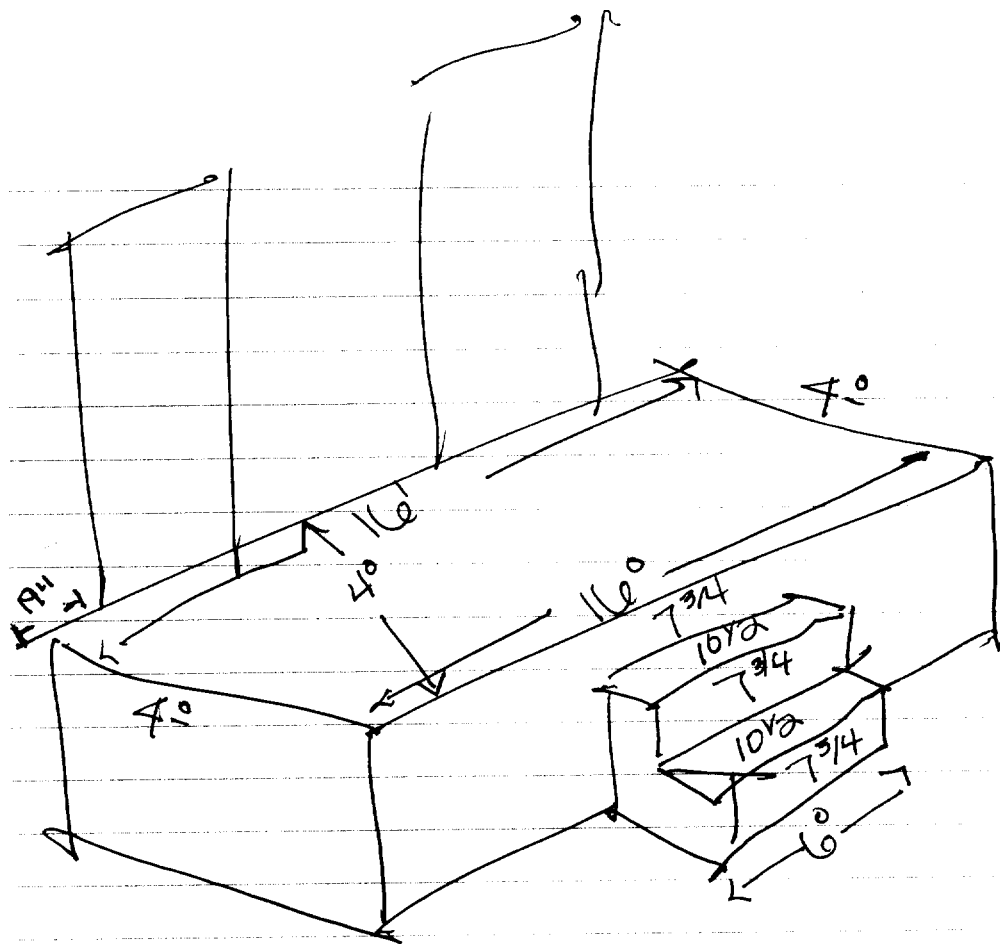

DEPT. OF BUILDING INSPECTION
 CITY OF PORTLAND, ME
 JUN 23 2005
 RECEIVED



CITY OF PORTLAND, MAINE

Department of Building Inspections

June 23 2015

Received from Amie C Delcamp

Location of Work 269 Wadsworth St

Cost of Construction \$ 1,000.00

Permit Fee \$ 30.00

Building (IL) Plumbing (I5) Electrical (I2) Site Plan (U2)

Other _____

CBL: 143 11 1460

Check #: 928

Total Collected \$ 30.00

THIS IS NOT A PERMIT

No work is to be started until PERMIT CARD is actually posted upon the premises. Acceptance of fee is no guarantee that permit will be granted. PRESERVE THIS RECEIPT. In case permit cannot be granted the amount of the fee will be refunded upon return of the receipt less \$10.00 or 10% whichever is greater.

Dona
WHITE - Applicant's Copy
YELLOW - Office Copy
PINK - Permit Copy