

City of Portland, Maine - Building or Use Permit Application

389 Congress Street, 04101 Tel: (207) 874-8703, Fax: (207) 874-8716

Permit No: 08-1181	Issue Date:	CBL: 143 A011001
-----------------------	-------------	---------------------

Location of Construction: 31 TREMAINE ST	Owner Name: REGAN TERESA A	Owner Address: 31 TREMAINE ST	Phone: 207-247-4874
Business Name:	Contractor Name: Dennis Warren	Contractor Address: 695 Ossipee Hill Road Waterboro	Phone 2072474874
Lessee/Buyer's Name	Phone:	Permit Type: HVAC	Zone: R-5

Past Use: Single Family Home	Proposed Use: Single Family Home - Install Peerless Burner	Permit Fee: \$70.00	Cost of Work: \$5,000.00	CEO District: 4
---------------------------------	---	------------------------	-----------------------------	--------------------

Proposed Project Description: Install Peerless Burner	FIRE DEPT: <input type="checkbox"/> Approved <input checked="" type="checkbox"/> Denied <i>W/A</i>	INSPECTION: Use Group: 12-3 Type: C <i>WAC</i>
--	---	--

PEDESTRIAN ACTIVITIES DISTRICT (P.A.D.)	Action: <input type="checkbox"/> Approved <input type="checkbox"/> Approved w/Conditions <input type="checkbox"/> Denied	Signature: _____ Date: _____
---	--	------------------------------

Permit Taken By: lmd	Date Applied For: 09/19/2008
-------------------------	---------------------------------

Zoning Approval

- This permit application does not preclude the Applicant(s) from meeting applicable State and Federal Rules.
- Building permits do not include plumbing, septic or electrical work.
- Building permits are void if work is not started within six (6) months of the date of issuance. False information may invalidate a building permit and stop all work..

Special Zone or Reviews
<input type="checkbox"/> Shoreland
<input type="checkbox"/> Wetland
<input type="checkbox"/> Flood Zone
<input type="checkbox"/> Subdivision
<input type="checkbox"/> Site Plan
Maj <input type="checkbox"/> Minor <input type="checkbox"/> MM <input type="checkbox"/>
Date: 9/19/08

Zoning Appeal
<input type="checkbox"/> Variance
<input type="checkbox"/> Miscellaneous
<input type="checkbox"/> Conditional Use
<input type="checkbox"/> Interpretation
<input type="checkbox"/> Approved
<input type="checkbox"/> Denied
Date: _____

Historic Preservation
<input checked="" type="checkbox"/> Not in District or Landmark
<input type="checkbox"/> Does Not Require Review
<input type="checkbox"/> Requires Review
<input type="checkbox"/> Approved
<input type="checkbox"/> Approved w/Conditions
<input type="checkbox"/> Denied
Date: 9/19/08

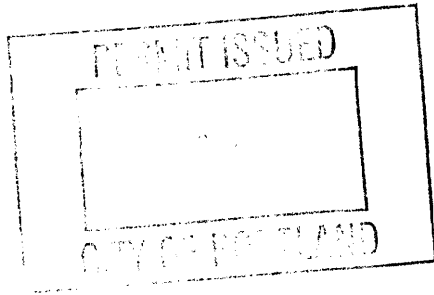

CERTIFICATION

I hereby certify that I am the owner of record of the named property, or that the proposed work is authorized by the owner of record and that I have been authorized by the owner to make this application as his authorized agent and I agree to conform to all applicable laws of this jurisdiction. In addition, if a permit for work described in the application is issued, I certify that the code official's authorized representative shall have the authority to enter all areas covered by such permit at any reasonable hour to enforce the provision of the code(s) applicable to such permit.

SIGNATURE OF APPLICANT	ADDRESS	DATE	PHONE
RESPONSIBLE PERSON IN CHARGE OF WORK, TITLE		DATE	PHONE

City of Portland, Maine - Building or Use Permit

389 Congress Street, 04101 Tel: (207) 874-8703, Fax: (207) 874-8716

Permit No: 08-1181	Date Applied For: 09/19/2008	CBL: 143 A011001
------------------------------	--	----------------------------

Location of Construction: 31 TREMAINE ST	Owner Name: REGAN TERESA A	Owner Address: 31 TREMAINE ST	Phone: 207-247-4874
Business Name:	Contractor Name: Dennis Warren	Contractor Address: 695 Ossipee Hill Road Waterboro	Phone: (207) 247-4874
Lessee/Buyer's Name	Phone:	Permit Type: HVAC	

Proposed Use: Single Family Home - Install Peerless Burner	Proposed Project Description: Install Peerless Burner
--	---

Dept: Zoning	Status: Approved	Reviewer: Tammy Munson	Approval Date: 09/19/2008
Note:			Ok to Issue: <input checked="" type="checkbox"/>
Dept: Building	Status: Approved with Conditions	Reviewer: Tammy Munson	Approval Date: 09/19/2008
Note:			Ok to Issue: <input checked="" type="checkbox"/>
1) The installation must comply with the State of Maine Gas Regulations.			



FILL IN AND SIGN WITH INK

143 A-061

APPLICATION FOR PERMIT HEATING OR POWER EQUIPMENT

To the INSPECTOR OF BUILDINGS, PORTLAND, ME.

The undersigned hereby applies for a permit to install the following heating, cooking or power equipment in accordance with the Laws of Maine, the Building Code of the City of Portland, and the following specifications:

Location / CBL _____ Use of Building _____ Date 9-19-08

Name and address of owner of appliance TERESA REGAN

31 TREMAINE ST,

Installer's name and address Dennis Warren

695 OSSIPPE HILL ROAD WATERBORO ME, 04087 Telephone 207-247-4874

Location of appliance:

- Basement
- Attic
- Floor
- Roof

Type of Fuel:

- Gas
- Oil
- Solid

SEP 19 2003

Appliance Name: Peerless Boiler

U.L. Approved Yes No

Will appliance be installed in accordance with the manufacture's installation instructions? Yes No

IF NO Explain: _____

The Type of License of Installer:

- Master Plumber # _____
- Solid Fuel # _____
- Oil # _____
- Gas # PNT 2459
- Other _____

Type of Chimney:

- Masonry Lined
Factory built _____
- Metal
Factory Built U.L. Listing # _____
- Direct Vent
Type _____ UL# _____

Type of Fuel Tank

- Oil
- Gas

Size of Tank _____

Number of Tanks _____

Distance from Tank to Center of Flame _____ feet.

Cost of Work: \$ 5000.00

Permit Fee: \$ _____

Approved

Approved with Conditions

Fire: _____

Ele.: _____

Bldg.: _____

- See attached letter or requirement

Inspector's Signature _____

Date Approved _____

Signature of Installer Dennis Warren

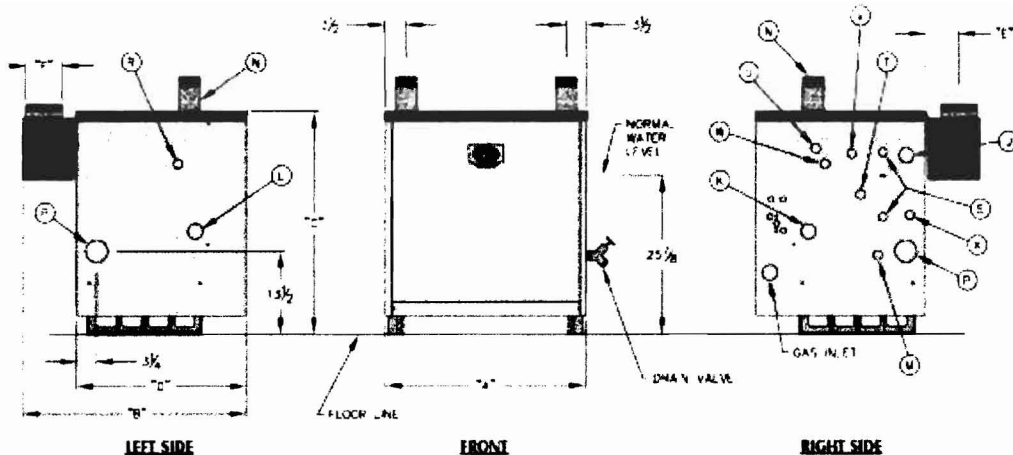

Series 63 Boiler Dimensions

Boiler Model	WidTD "A"	DepTD "B"	Top to Floor "C"	Jacket DepTD "D"	Rear of Jacket to c/l of Flue "E"	Flue Size "F"
63-03L	16 1/8"	37 1/4"	36 3/8"	28 1/8"	5 5/8"	6"
63-03	16 1/8"	37 1/4"	36 3/8"	28 1/8"	5 5/8"	6"
63-04L	20 3/8"	37 1/4"	36 3/8"	28 1/8"	5 1/8"	7"
63-04	20 3/8"	37 1/4"	36 3/8"	28 1/8"	5 1/8"	7"
63-05L	24 5/8"	39 1/4"	36 3/8"	28 1/8"	6 5/8"	8"
63-05	24 5/8"	39 1/4"	36 3/8"	28 1/8"	6 5/8"	8"
63-06	28 7/8"	39 1/4"	36 3/8"	28 1/8"	6 1/8"	9"

Tapping Locations

Tap ID	Size N.P.T.	Steam	Water
j	1 1/4"	Skim Tapping	Skim Tapping
K	1"	Tank Supply/Limit	N/A
L	1"	Tank Return	N/A
M	3/4"	Boiler Drain	Boiler Drain
N	3"	Supply	Supply
P	2 1/2"	Return	Return
R	3/4"	Safety Valve	Relief Valve
S	1/2"	Gauge Glass	N/A
T	3/4"	Primary Probe Low Water Cut-Off	N/A
U	3/4"	Primary Limit	Primary Limit
V	3/4"	Secondary Limit	Pressure/Temperature Gauge
W	3/4"	Pressure Gauge	Secondary Limit
X	3/4"	Secondary Probe Low Water Cut-Off	N/A

Don't see the information you need? See the "Related Documents" tab for product resource downloads.