

EAST

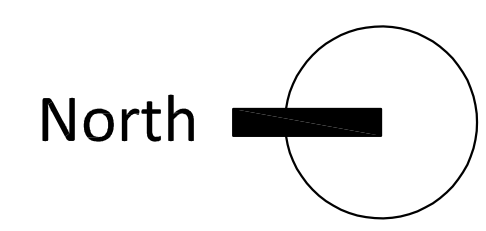
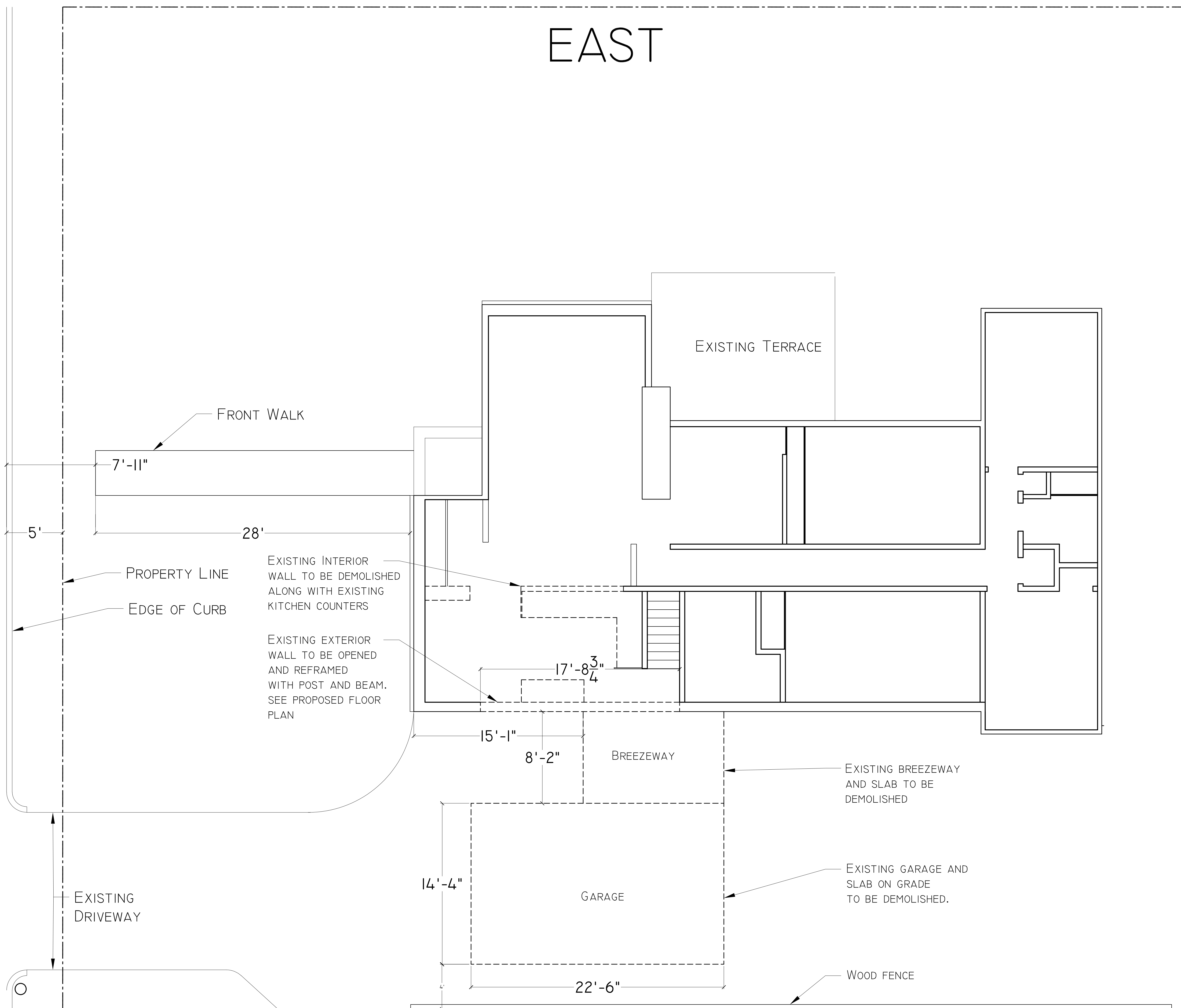

Drawing Scale:
1/4" = 1'-0"

Drawing Date:
3.30.18

Sheet Title:
Existing
Conditions

Sheet Number:
A-1.0

EAST

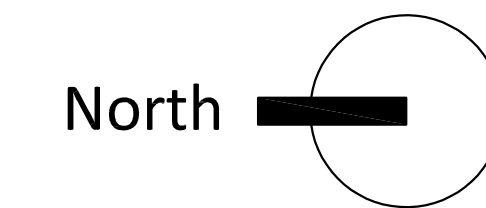
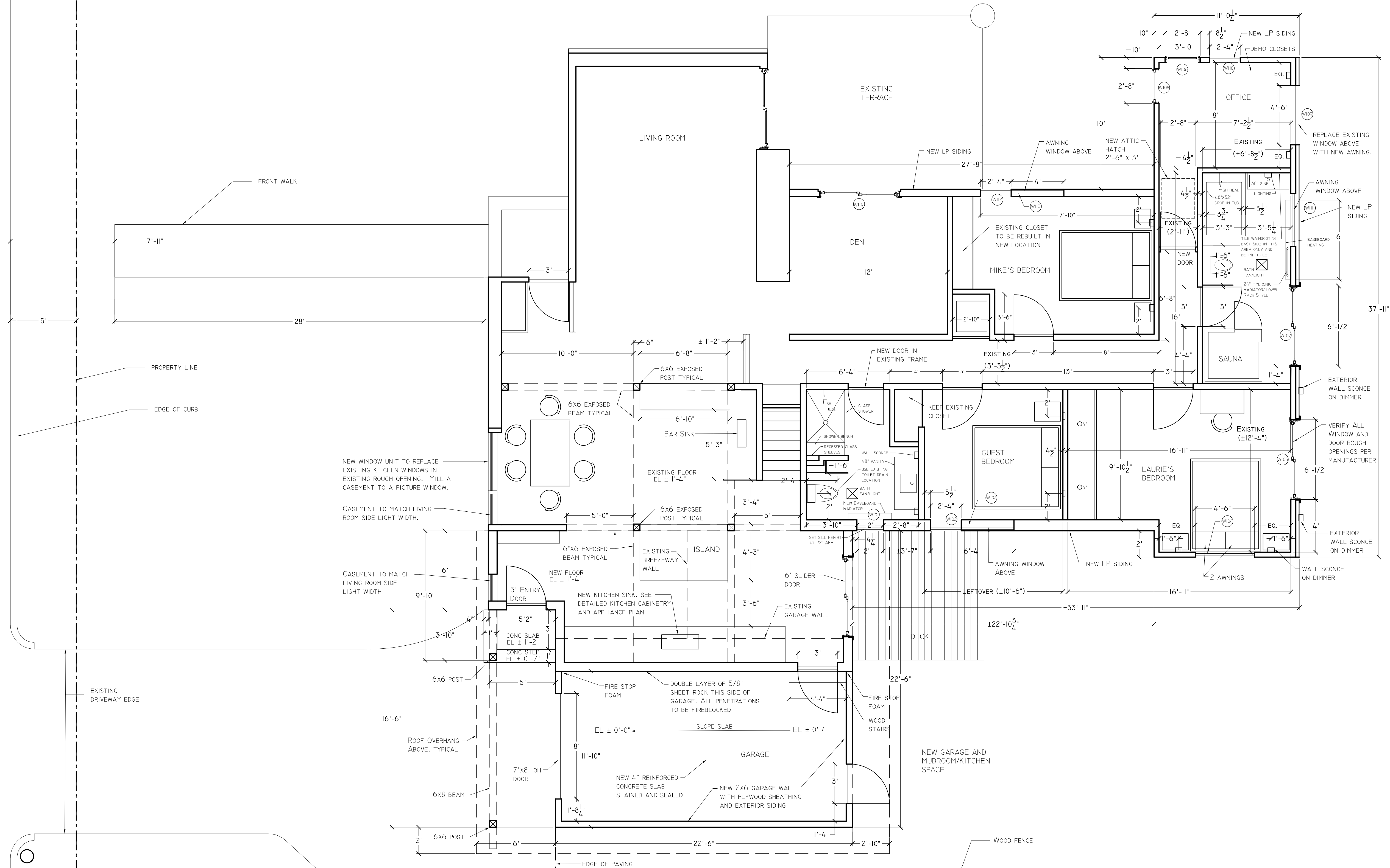

Drawing Scale:
1/4" = 1'-0"

Drawing Date:
4.29.18

Sheet Title:
**Proposed
Floor Plan**

Sheet Number:
A-1.1

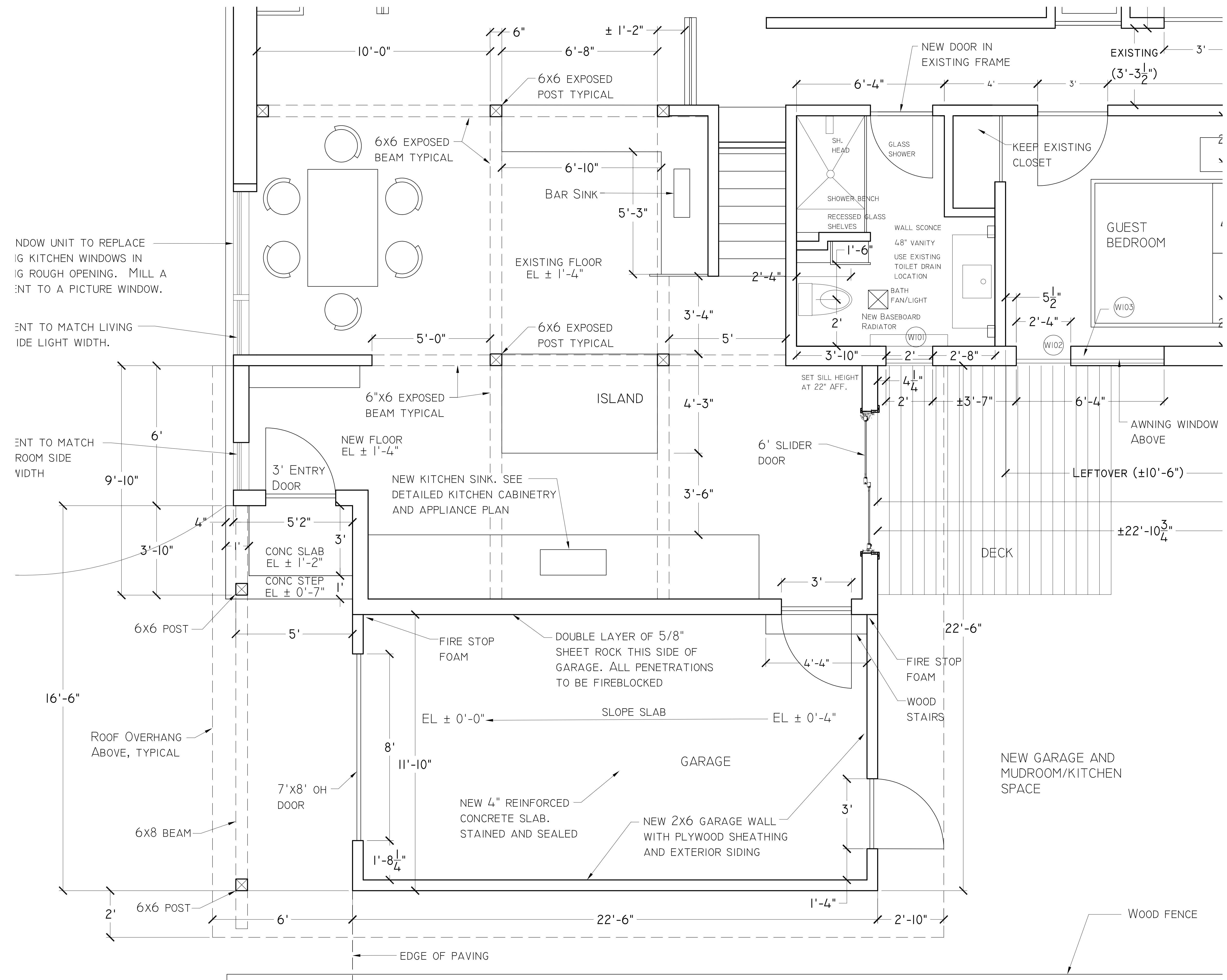

WINDOW UNIT TO REPLACE
EXISTING KITCHEN WINDOWS IN
EXISTING ROUGH OPENING. MILL AND
INSTALL TO A PICTURE WINDOW.

FINISH TO MATCH LIVING
ROOM SIDE LIGHT WIDTH.

FINISH TO MATCH
ROOM SIDE
WIDTH

16'-6"

ROOF OVERHANG
ABOVE, TYPICAL

6x8 BEAM

6x6 POST

7'x8' OH
DOOR

EDGE OF PAVING

FIRE STOP
FOAM

DOUBLE LAYER OF 5/8"
SHEET ROCK THIS SIDE OF
GARAGE. ALL PENETRATIONS
TO BE FIREBLOCKED

NEW 4" REINFORCED
CONCRETE SLAB.
STAINED AND SEALED

NEW 2x6 GARAGE WALL
WITH PLYWOOD SHEATHING
AND EXTERIOR SIDING

6' SLIDER
DOOR

FIRE STOP
FOAM

WOOD
STAIRS

NEW GARAGE AND
MUDROOM/KITCHEN
SPACE

WOOD FENCE

North

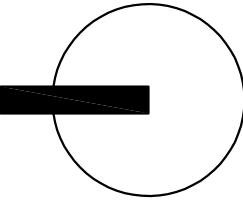

Drawing Scale:
1/2" = 1'-0"

Drawing Date:
04.29.18

Sheet Title:
Proposed
Kitchen/Garage
Plan

Sheet Number:
A-1.2

EAST ELEVATION: FRONT BATH, GUEST ROOM, LAURIE'S ROOM

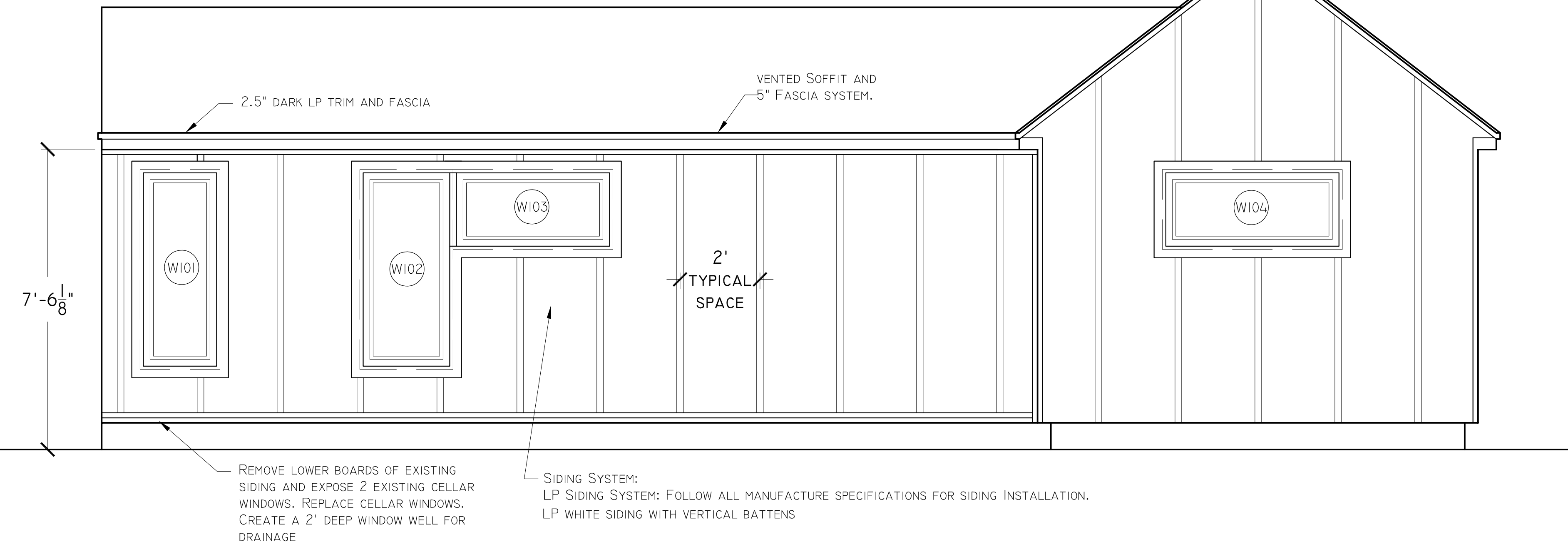

NORTH ELEVATION: LIVING ROOM

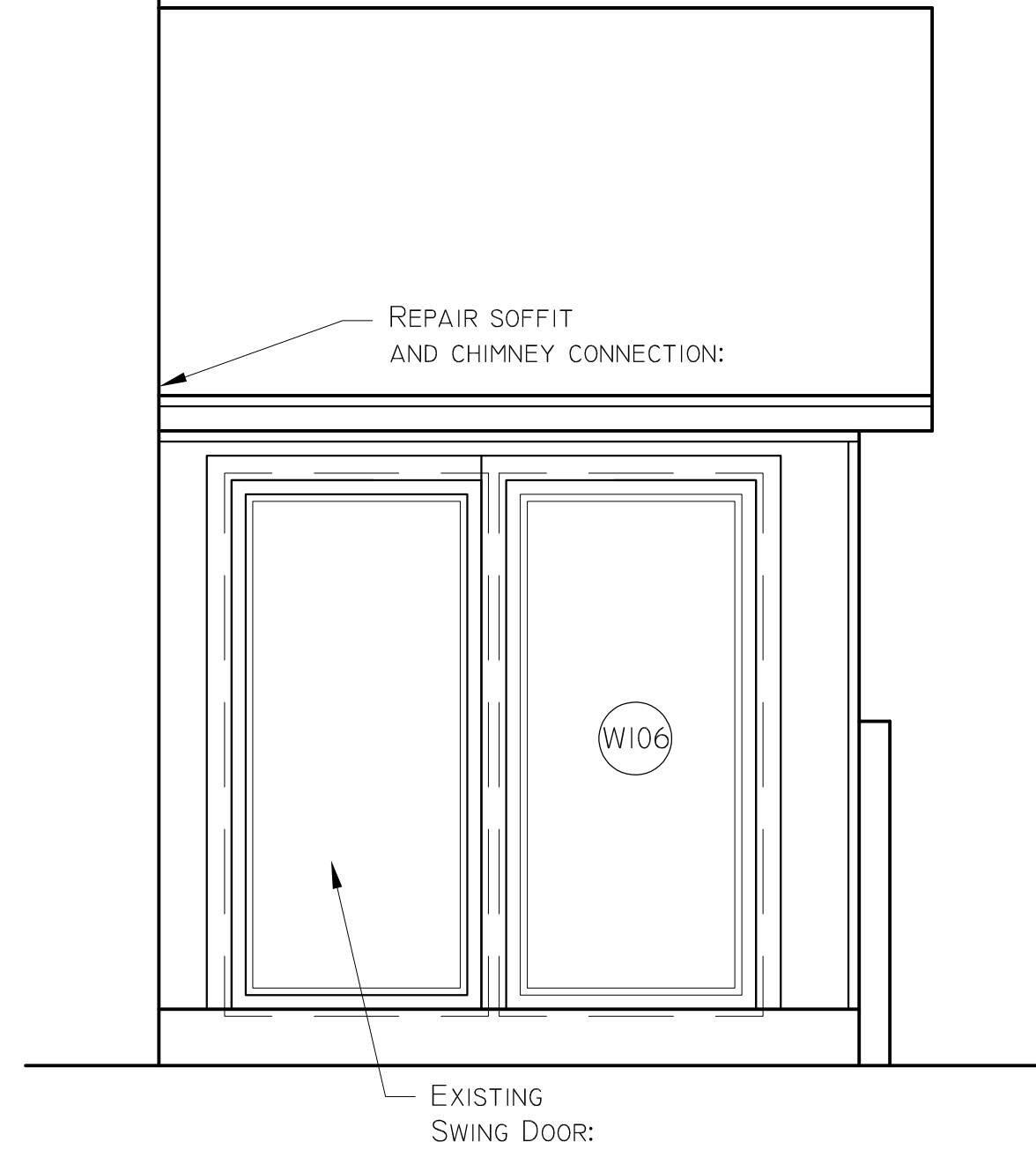

NORTH ELEVATION: LAURIE'S BEDROOM, BACK BATH, OFFICE

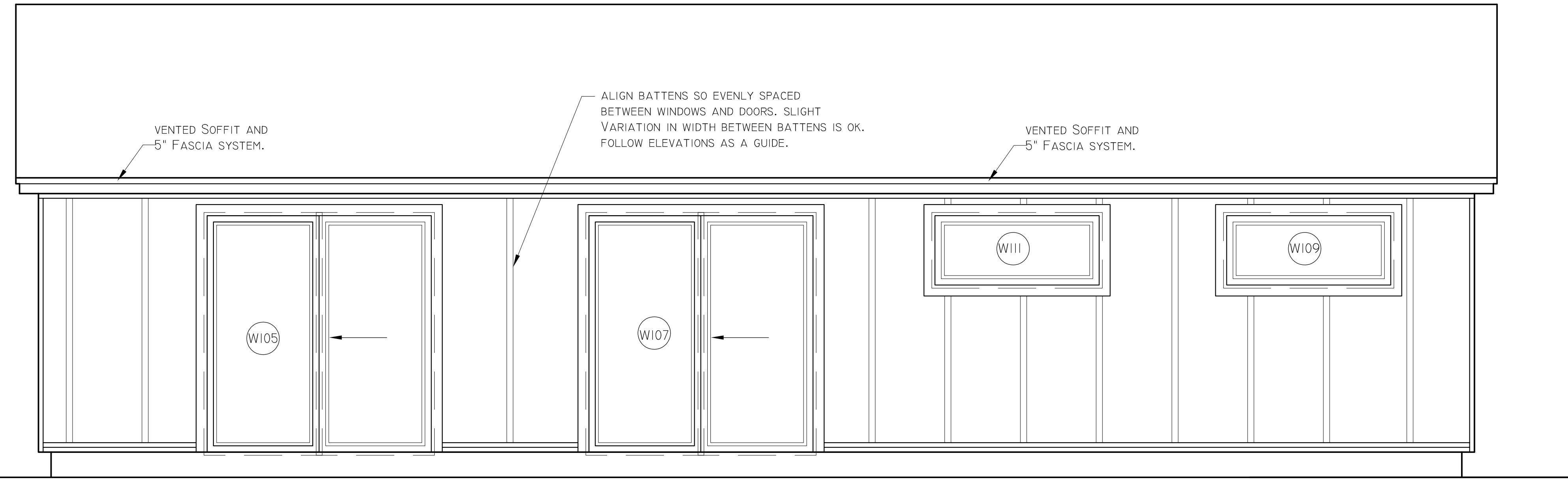

SOUTH ELEVATION: OFFICE

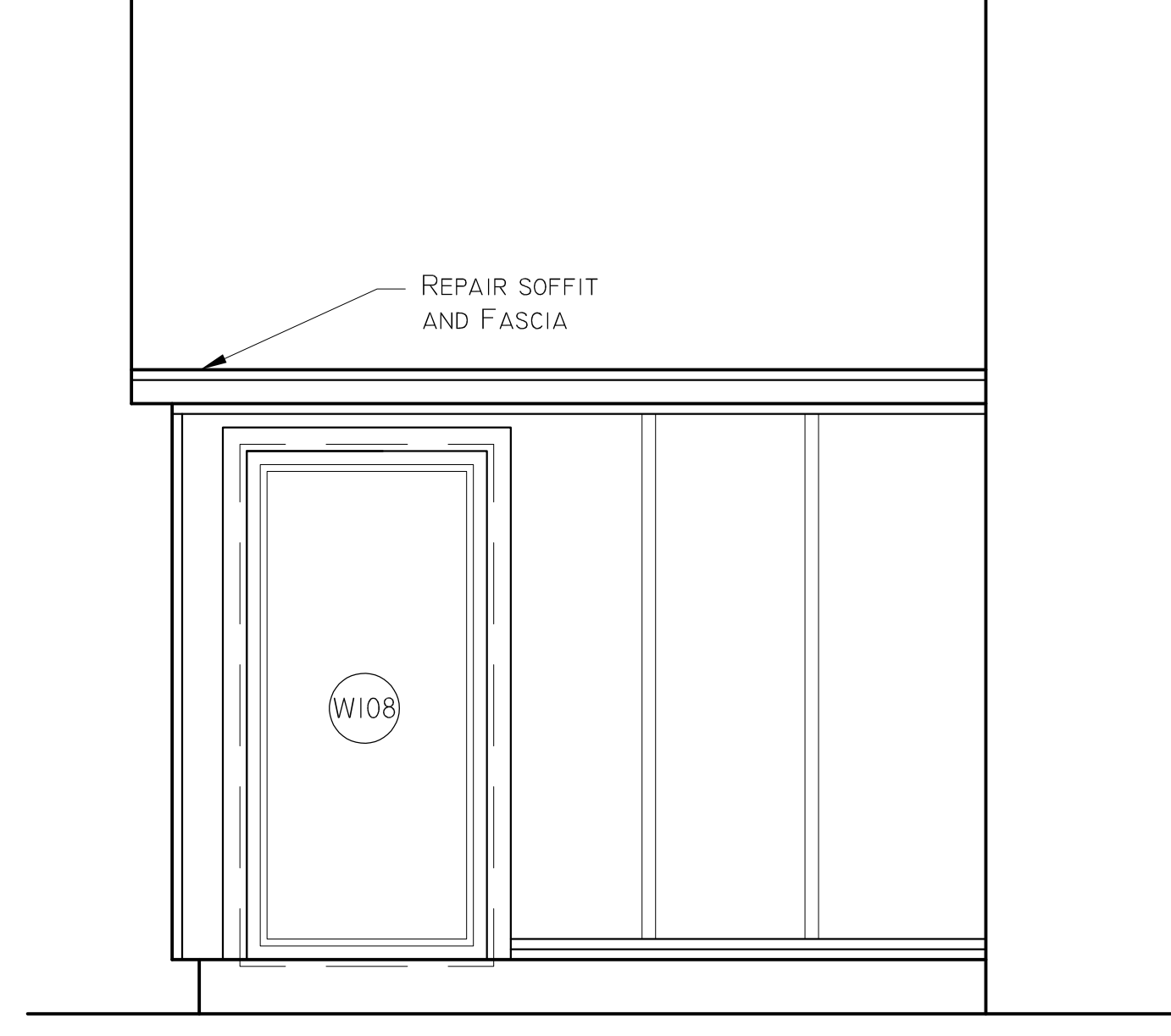

WEST ELEVATION: OFFICE, MIKE'S ROOM, DEN

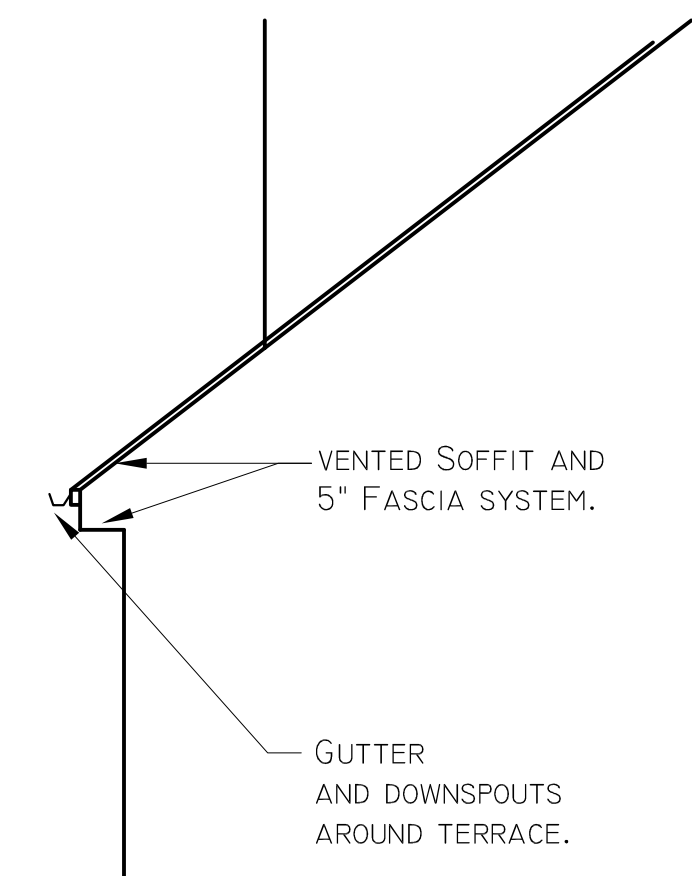
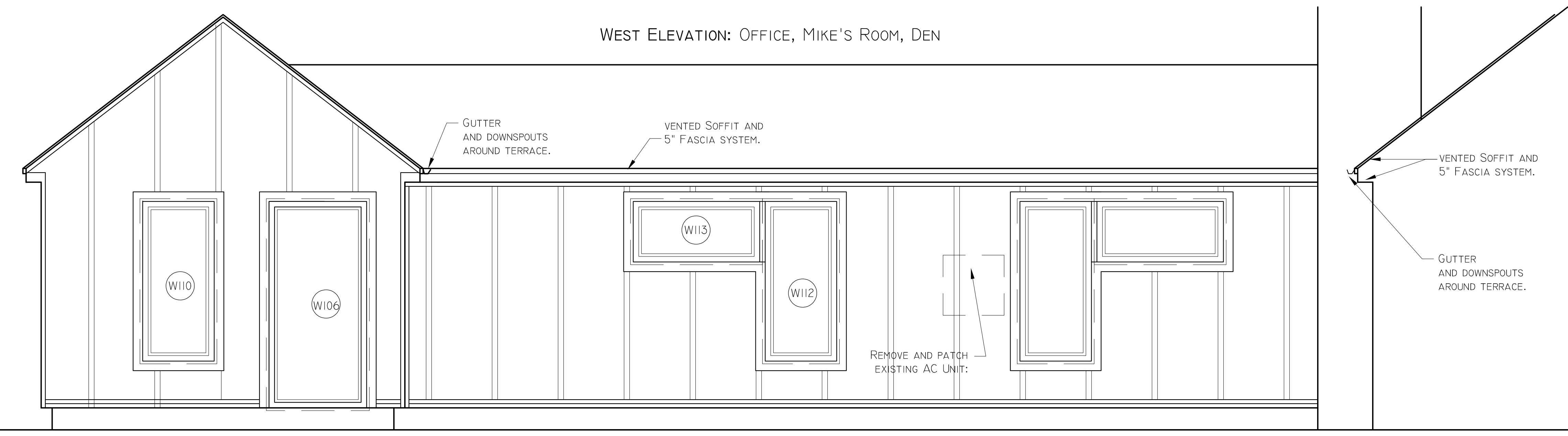

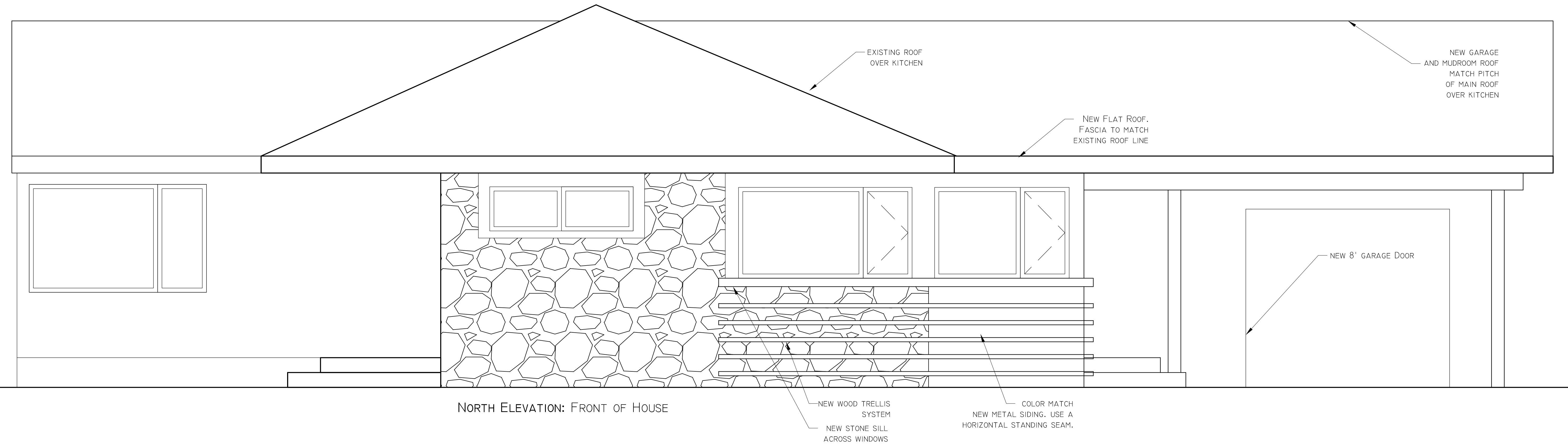
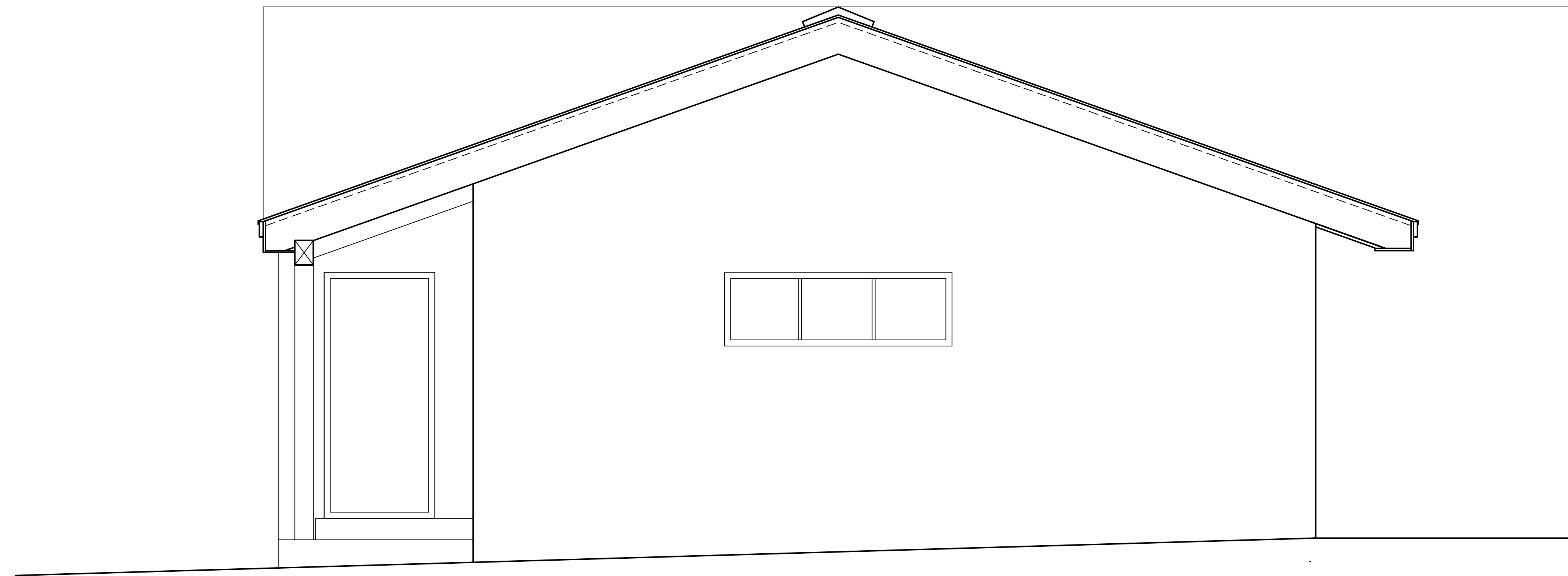

NORTH ELEVATION: FRONT OF HOUSE

Drawing Scale:
1/2" = 1'-0"

Drawing Date:
04.29.18

Sheet Title:
**Proposed
Kitchen
Section**

Sheet Number:
A-2.1

NOTE:
VENTILATION PROVIDED THROUGH
EXISTING BASEMENT WINDOWS AND
PROVIDE SUPPLEMENTAL MECHANICAL
VENTILATION AS NEEDED.

SAW-CUT NEW 5'X 3' OPENING IN
EXISTING FOUNDATION WALL FOR
VENTILATION AND ACCESS

RUN EXISTING
ELECTRICAL AND
WATER SERVICES
FROM EXISTING
SIDE.

TIE NEW FROST WALL INTO EXISTING
FOUNDATION WALL WITH #4 DOWELS
AT 12" OC

WATERPROOF COATING AND 2" FOAM
BOARD ON OUTSIDE OF FOUNDATION
WALL ALONG EXTERIOR PERIMETER.

FOR DECK FRAMING SEE SHEET S-1.1

8" REINFORCED CONCRETE FROST WALL.
REINFORCE WITH #4 AT 18" OC
VERTICAL, #4 AT 12" OC HORIZONTAL.
T/WALL EL 0'-4 1/2"

8" x 20" REINFORCED CONCRETE FOOTING WITH
(2) #5 CONTINUOUS. SET ON COMPACTED GRAVEL
AND/OR NATIVE SOIL IF DEEMED SOLID. IF CLAY
OR LOOSE, REINFORCE WITH COMPACTED CRUSHED
ROCK TO A DEPTH OF 8" BELOW FOOTING. B/FTG
EL -5'-0" TYP U.N.O.

4" DRAIN TILE AROUND FOUNDATION
FOOTING. BACKFILL WITH 12" CRUSHED
STONE AND FILTER FABRIC PRIOR TO
BACKFILL OF NATIVE SOILS.

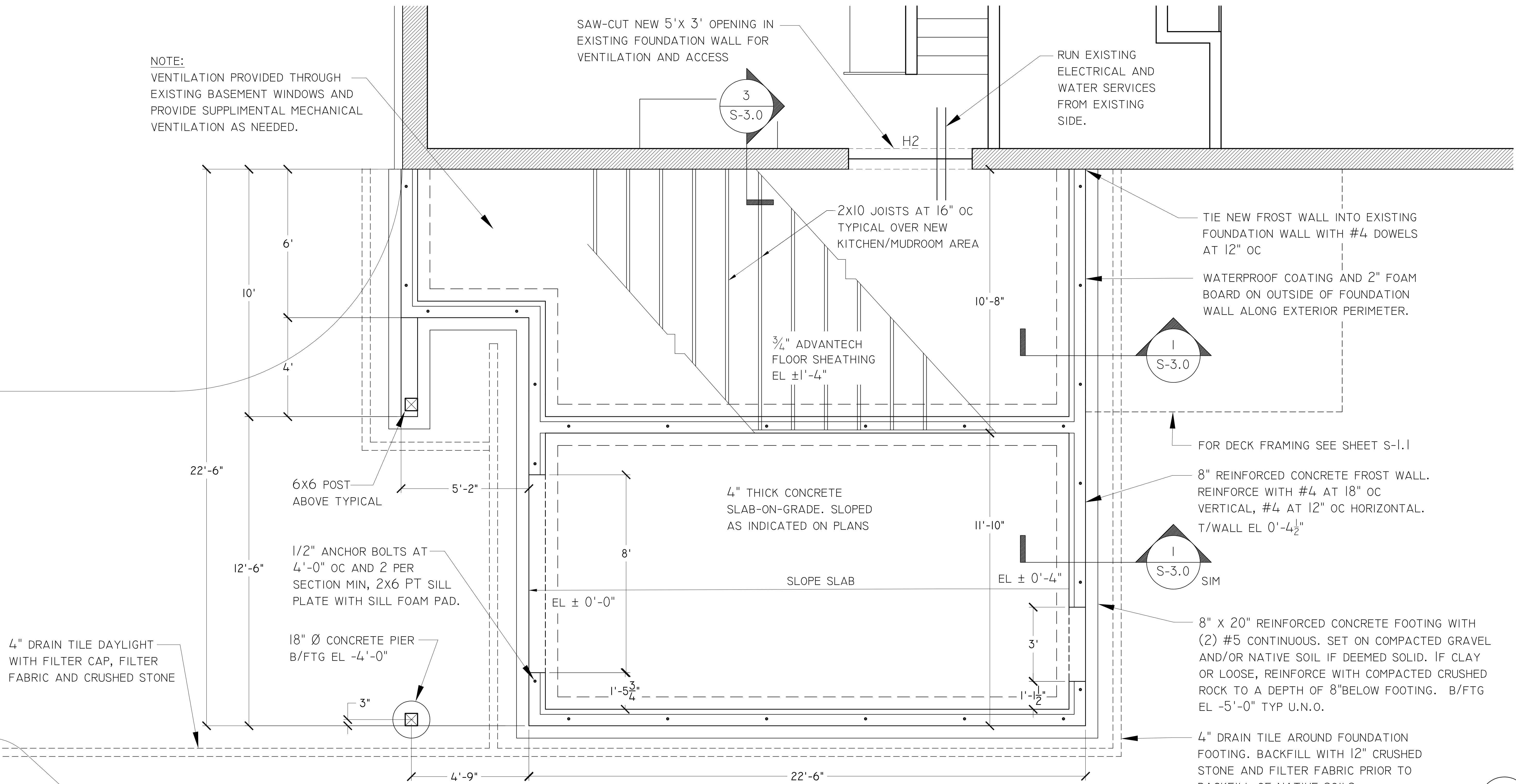

4" DRAIN TILE DAYLIGHT
WITH FILTER CAP, FILTER
FABRIC AND CRUSHED STONE

6x6 POST
ABOVE TYPICAL

1/2" ANCHOR BOLTS AT
4'-0" OC AND 2 PER
SECTION MIN, 2X6 PT SILL
PLATE WITH SILL FOAM PAD.

18" Ø CONCRETE PIER
B/FTG EL -4'-0"

4" THICK CONCRETE
SLAB-ON-GRADE. SLOPED
AS INDICATED ON PLANS

SLOPE SLAB

CONCRETE NOTES:

- CONCRETE WORK SHALL CONFORM TO ACI 308 "STANDARD SPECIFICATION FOR STRUCTURAL CONCRETE IN BUILDINGS" AND ACI 309 "BUILDING CODE REQUIREMENTS FOR REINFORCED CONCRETE." HOT AND COLD WEATHER CONCRETING SHALL BE IN ACCORDANCE WITH ACI 308R AND 309R, RESPECTIVELY.
- CEMENT SHALL CONFORM TO ASTM C150 TYPE I OR II.
- AGGREGATES SHALL CONFORM TO ASTM C33. MAXIMUM SIZE AGGREGATE SHALL BE 2" NOMINAL AT FOUNDATIONS, AND 1 1/2" NOMINAL AT SLABS ON GROUND, UNLESS NOTED OTHERWISE.
- MAXIMUM SLUMP SHALL BE 4".
- PROVIDE CONCRETE MIX DESIGNS INCORPORATING THE FOLLOWING REQUIREMENTS:
 - FOOTINGS:
 - COMPRESSIVE STRENGTH AT 28 DAYS: 3000 PSI
 - MINIMUM CEMENT CONTENT: 423 LB/CU YD
 - MINIMUM WATER CEMENT RATIO: 0.50
 - AIR ENTRAINMENT: OPTIONAL
 - WALLS AND SLAB-ON-GRADE:
 - COMPRESSIVE STRENGTH AT 28 DAYS: 4000 PSI
 - MINIMUM CEMENT CONTENT: 397 LB/CU YD
 - MINIMUM WATER CEMENT RATIO: 0.48
 - AIR ENTRAINMENT: 4% TO 6% FOR WALLS; 0% FOR S.O.G.
 - SYNTHETIC FIBERS IN S.O.G. ONLY
- CONCRETE MIX CURATION TIMES SHALL BE LIMITED TO LESS THAN 90 MINUTES, WITHOUT EXCEPTION FOR ANY REASON.
- CONCRETE SHALL NOT BE PLACED IN WATER OR ON FROZEN GROUND.
- PROVIDE A VAPOR BARRIER UNDER INTERIOR SLABS ON GROUND. VAPOR BARRIER SHALL BE A MINIMUM OF 6 MIL THICKNESS OF EXTRUDED POLYETHYLENE FILM CONFORMING TO ASTM D6878 CLASS II PLASTICS WITH A HOOPED PERMEANCE NOT EXCEEDING 0.02 PERMS. VAPOR BARRIER SHALL BE EQUAL TO STEGO WRAP BY STEGO INDUSTRIES LLC.
- REINFORCING BARS SHALL CONFORM TO ASTM A635 GRADE 60 DEFORMED BARS AND SHALL BE DETAILED, FABRICATED AND PLACED IN ACCORDANCE WITH ACI 308. WELDING OF REINFORCEMENT SHALL NOT BE PERMITTED.
- WELDED WIRE FABRIC SHALL CONFORM TO ASTM A185 AND BE PROVIDED IN FLAT SHEETS.
- MINIMUM PROTECTIVE CONCRETE COVER OVER REINFORCEMENT, UNLESS NOTED OTHERWISE, SHALL BE:
 - SURFACES CAST AGAINST AND PERMANENTLY IN CONTACT WITH EARTH: 3"
 - FORMED SURFACES IN CONTACT WITH EARTH OR EXPOSED TO WEATHER:
 - FOR #5 BARS AND SMALLER: 1 1/2"
 - FOR #6 BARS AND LARGER: 2"
 - SURFACES NOT IN CONTACT WITH EARTH OR EXPOSED TO WEATHER:
 - FOR #5 BARS AND SMALLER FOR SLABS, WALLS, JOISTS: 1"
 - FOR #6 REINFORCEMENT OF BEAMS, GIRDERS AND COLUMNS: 1 1/2"
- ANCHOR RODS THAT ARE IN CONTACT WITH PRESSURE TREATED LUMBER SHALL BE HOT-DIPPED GALVANIZED.
- ALL ITEMS TO BE EMBEDDED INTO CONCRETE SHALL BE INSTALLED PRIOR TO PLACEMENT OF CONCRETE. PROVIDE ADDITIONAL REINFORCEMENT AND/OR TEMPLATES AS REQUIRED TO ENSURE THE CORRECT POSITION OF EMBEDMENTS. "WET SETTING" OF EMBEDMENTS (INCLUDING ANCHOR BOLTS) INTO CONCRETE IS PROHIBITED.

WOOD FRAMING NOTES:

- ALL WOOD FRAMING MATERIAL SHALL BE SURFACED DRY AND USED AT 19% MAXIMUM MOISTURE CONTENT. ALLOWABLE STRESS REQUIREMENTS OF ALL MATERIALS SHALL BE IN ACCORDANCE WITH NDS "NATIONAL DESIGN SPECIFICATIONS FOR WOOD CONSTRUCTION WITH COMMENTARY."
- LUMBER SHALL BE HEM FIR NO2 OR SPRUCE-FINE-FIR NO1/2 OR BETTER, WITH MINIMUM ALLOWABLE STRESSES EQUAL TO THE FOLLOWING:
 - ALLOWABLE BENDING STRESS (Fb) = 875 PSI
 - ALLOWABLE SHEAR STRESS (Fv) = 135 PSI
 - ALLOWABLE COMPRESSION PARALLEL TO GRAIN (Fc) = 1050 PSI
 - MODULUS OF ELASTICITY (E) = 1,400,000 PSI
- PROVIDE ONE ROW OF FULL-DEPTH WOOD BLOCKING AT MID-HEIGHT OF ALL LOAD BEARING WALLS UP TO 8'-0" IN HEIGHT, AND AT 4'-0" MAXIMUM FOR FULL HEIGHT OF WALL.
- BORED OR CUT HOLES SHALL NOT EXCEED ONE-THIRD OF THE DEPTH OF ANY UN-REINFORCED STRUCTURAL WALL STUD. EDGES OF HOLES SHALL NOT BE LOCATED CLOSER THAN 2" FROM THE EDGE OF THE STUD. STRUCTURAL WALL STUDS MAY HAVE BORED OR CUT HOLES UP TO ONE-HALF THE STUD DEPTH ONLY IF ADDITIONAL STUDS ARE INSTALLED OR SIMPSON STRONG-TIE TYPE SS3.5 STUD SHIMS ARE USED. HOLES ARE NOT ALLOWED IN POSTS OR COLUMNS UNLESS SPECIFICALLY DETAILED ON THE STRUCTURAL DRAWINGS.
- PROVIDE PRESSURE-TREATED LUMBER AT WALL SILL, PLATE MEMBERS, EXTERIOR EXPOSURE, AND ALL LOCATIONS WHERE LUMBER WILL BE IN CONTACT WITH MASONRY OR CONCRETE. TIMBER SHALL BE TREATED SOUTHERN YELLOW PINE IN ACCORDANCE WITH AWPA STANDARD 11.
- BUILT-UP POSTS AND BEAMS SHALL BE FASTENED TOGETHER WITH A MINIMUM OF TWO 100 NAILS AT 8" O.C. UNO IN PLANS. FASTENING SHALL BE PLACED INTO EACH PLY.
- EXTERIOR NON-LOAD BEARING INSULATION PANELS SUPPORTING SIDING SHALL BE FASTENED TO WALL STUDS PER SPECIFICATIONS.
- AT CONNECTIONS NOT SPECIFICALLY DETAILED, FASTENING SHALL BE IN ACCORDANCE WITH THE WOOD FRAMING SECTION IN THE 2018 IRC.
- NAIL SIZES INDICATED ON THE DRAWINGS ARE COMMON WIRE NAIL SIZES (AS DEFINED BY THE AF&PA), WITH THE FOLLOWING DIMENSIONS:
 - 60: 0.131" DIAMETER SHANK, 0.266" DIAMETER HEAD, 2" LONG
 - 80: 0.131" DIAMETER SHANK, 0.281" DIAMETER HEAD, 2 1/2" LONG
 - 100: 0.148" DIAMETER SHANK, 0.312" DIAMETER HEAD, 3" LONG
 - 120: 0.148" DIAMETER SHANK, 0.312" DIAMETER HEAD, 3 1/2" LONG
 - 160: 0.164" DIAMETER SHANK, 0.344" DIAMETER HEAD, 3 1/2" LONG
- ALL WOOD CONNECTORS (JOIST AND BEAM HANGERS, POST CAPS AND BASES, AND TIES) SHALL BE GALVANIZED STEEL CONNECTORS AS MANUFACTURED BY SIMPSON STRONG-TIE (OR AN APPROVED EQUIVALENT).
- CONNECTORS AND FASTENERS EXPOSED TO THE WEATHER AND/OR IN CONTACT WITH PRESERVATIVE TREATED LUMBER SHALL BE STAINLESS STEEL. IF ALTERNATE COATINGS ARE PROPOSED BY THE CONTRACTOR OR FASTENER MANUFACTURER, SUBMIT PRODUCT DATA FOR REVIEW PRIOR TO PURCHASE. FASTENERS SHALL MATCH THE TYPE OF CONNECTOR BEING USED.

PLYWOOD SHEATHING NOTES:

- ALL PLYWOOD CONSTRUCTION SHALL BE IN ACCORDANCE WITH THE AMERICAN PLYWOOD ASSOCIATION (APA) SPECIFICATIONS.
- ALL ROOF PANEL SHEATHING SHALL BE 2" (NOMINAL) TYPE CDX, EXP 1 APA RATED SHEATHING. SUITABLE EDGE SUPPORT SHALL BE PROVIDED BY USE OF CLIPS OR BLOTTING BETWEEN FRAMING. UNLESS OTHERWISE NOTED, CONNECT ROOF SHEATHING WITH 80 COMMON NAILS AT 6" O.C. PERIMETER, 6" O.C. PANEL EDGES AND 12" O.C. IN THE FIELD.
- ALL FLOOR SHEATHING SHALL BE 2" (NOMINAL) APA RATED STURD-FLOOR, EXP 1, WITH TONGUE AND GROOVE EDGE. UNLESS OTHERWISE NOTED, CONNECT FLOOR SHEATHING WITH 80 COMMON NAILS AT 6" O.C. PERIMETER, 6" O.C. PANEL EDGES AND 12" O.C. IN THE FIELD. FIELD GLUE USING ADHESIVES MEETING APA SPECIFICATION APG-DL APPLIED IN ACCORDANCE WITH THE MANUFACTURER'S RECOMMENDATIONS.
- ALL WALL PANEL SHEATHING SHALL BE 2" (NOMINAL) TYPE CDX, EXP 1 APA RATED SHEATHING. UNLESS OTHERWISE NOTED, CONNECT WALL SHEATHING WITH 80 COMMON NAILS AT 6" O.C. PERIMETER, 6" O.C. PANEL EDGES AND 12" O.C. IN THE FIELD, U.N.O.
- INSTALL ALL PLYWOOD SHEATHING WITH THE LONG DIMENSION OF THE PANEL ACROSS SUPPORTS AND WITH PANEL CONTINUOUS OVER TWO OR MORE SPANS. STAGGER END JOINTS. ALLOW 1/8" SPACING AT PANEL ENDS AND EDGES UNLESS OTHERWISE RECOMMENDING BY THE SHEATHING MANUFACTURER.
- ALL NAILING NOT OTHERWISE INDICATED SHALL BE IN ACCORDANCE WITH THE "NAILING SCHEDULE" ON THE TYPICAL DETAIL SHEET. NAILING SHALL NOT BE OVERRIDDEN.

DESIGN INFORMATION:

- THE STRUCTURE IS DESIGNED TO CARRY THE FOLLOWING LIVE LOADS, IN ADDITION TO ALL THE DEAD LOADS OF THE VARIOUS SYSTEMS AS PROVIDED TO THE STRUCTURAL ENGINEER AT THE TIME OF THE ISSUANCE OF THESE DRAWINGS, IN CONFORMANCE WITH THE APPLICABLE REQUIREMENTS OF THE FOLLOWING STANDARDS:
 - INTERNATIONAL RESIDENTIAL CODE (IRC) 2015 AMENDED BY THE MAINE UNIFORM BUILDING AND ENERGY CODE (MUBEC).
 - ASCE 7-10 "MINIMUM DESIGN LOADS FOR BUILDINGS AND OTHER STRUCTURES".
- GEOTECHNICAL DESIGN CRITERIA:**
 - FOUNDATION DESIGN BEARING CAPACITY IS BASED ON USING THE FOLLOWING ALLOWABLE NET SOIL BEARING PRESSURES:
 - COLUMN FOOTINGS: 2500 PSF
 - CONTINUOUS WALL FOOTINGS: 2500 PSF
 - NOTIFY THE STRUCTURAL ENGINEER OF RECORD (SER) IF UNSUITABLE MATERIALS ARE ENCOUNTERED BEFORE PROCEEDING WITH THE AFFECTED AREA OF WORK.
- DEAD LOADS:
 - ESTIMATED SELF-WEIGHT OF STRUCTURE AND ANY COMPONENTS OR FIXTURES CONSIDERED PERMANENT.
- SNOW LOAD:
 - DESIGN GROUND SNOW LOAD, Pg: 60 PSF
 - TERRAIN CATEGORY: B
 - SNOW OCCUPANCY CATEGORY: II
 - SNOW LOAD IMPORTANCE FACTOR, Is: 1.0
 - SNOW EXPOSURE FACTOR, Ce: 1.0
 - THERMAL FACTOR, Ct: 1.0
 - DESIGN FLAT-ROOF SNOW LOAD: 42 PSF
 - UNBALANCED, DRIFTING AND SLIDING SNOW IN ACCORDANCE WITH CHAPTER 7 OF ASCE 7
- WIND LOADS:
 - WIND OCCUPANCY CATEGORY: II
 - BASIC WIND SPEED (3-SECOND GUST), Vw: 117 MPH
 - WIND IMPORTANCE FACTOR, Iw: 1.00
 - WIND EXPOSURE: D
 - WIND DIRECTIONALITY FACTOR, Kd: 0.85
 - TOPOGRAPHIC FACTOR, Kzt: 1.0
 - ENCLOSURE CLASSIFICATION: ENCLOSED
 - INTERNAL PRESSURE COEFFICIENT, GCp: +0.18
 - COMPONENTS & CLADDING LOADS IN ACCORDANCE WITH CHAPTER 6 OF ASCE 7
- SEISMIC LOADS:
 - BUILDING OCCUPANCY CATEGORY: II
 - IMPORTANCE FACTOR, Ie: 1.0
 - SITE CLASS: D
 - SHORT PERIOD ACCELERATION Ss (Ssd): 0.242 (0.255)
 - 1-SECOND PERIOD ACCELERATION S1 (Ssd): 0.078 (0.188)
 - SEISMIC DESIGN CATEGORY: B

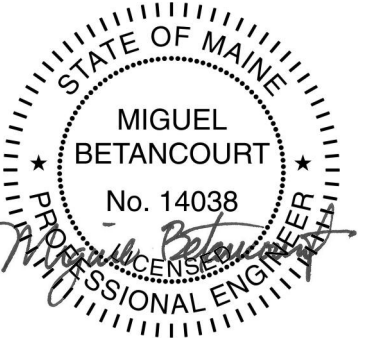
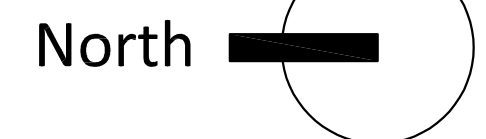

Drawing Scale:
1/2" = 1'-0"

Drawing Date:
04.29.18

Sheet Title:
**Proposed
Foundation
Plan**

Sheet Number:
S-1.0

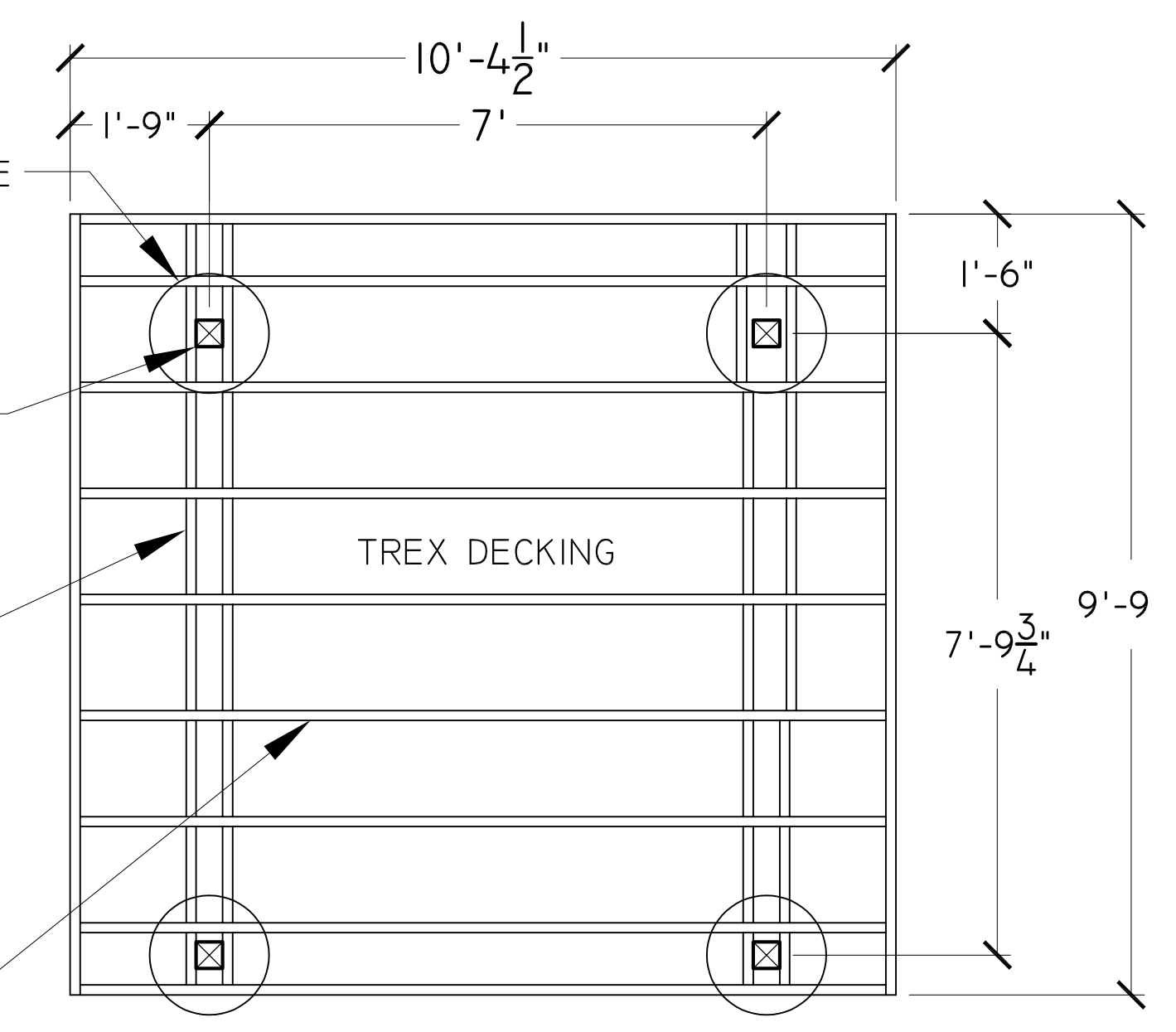

DECK FRAMING PLAN

18" Ø x 8" CONCRETE FOOTING ON A BED OF CRUSHED STONE, TYPICAL

4x4 PT POST DOWN TO FOOTING, TYPICAL

2x6 PT BEAM ON EITHER SIDE OF 4x4 PT POST. PROVIDE THRU-BOLTED CONNECTION AND PROVIDE BLOCKING

2x6 PT JOISTS AT 16" OC. PROVIDE BLOCKING BETWEEN JOISTS

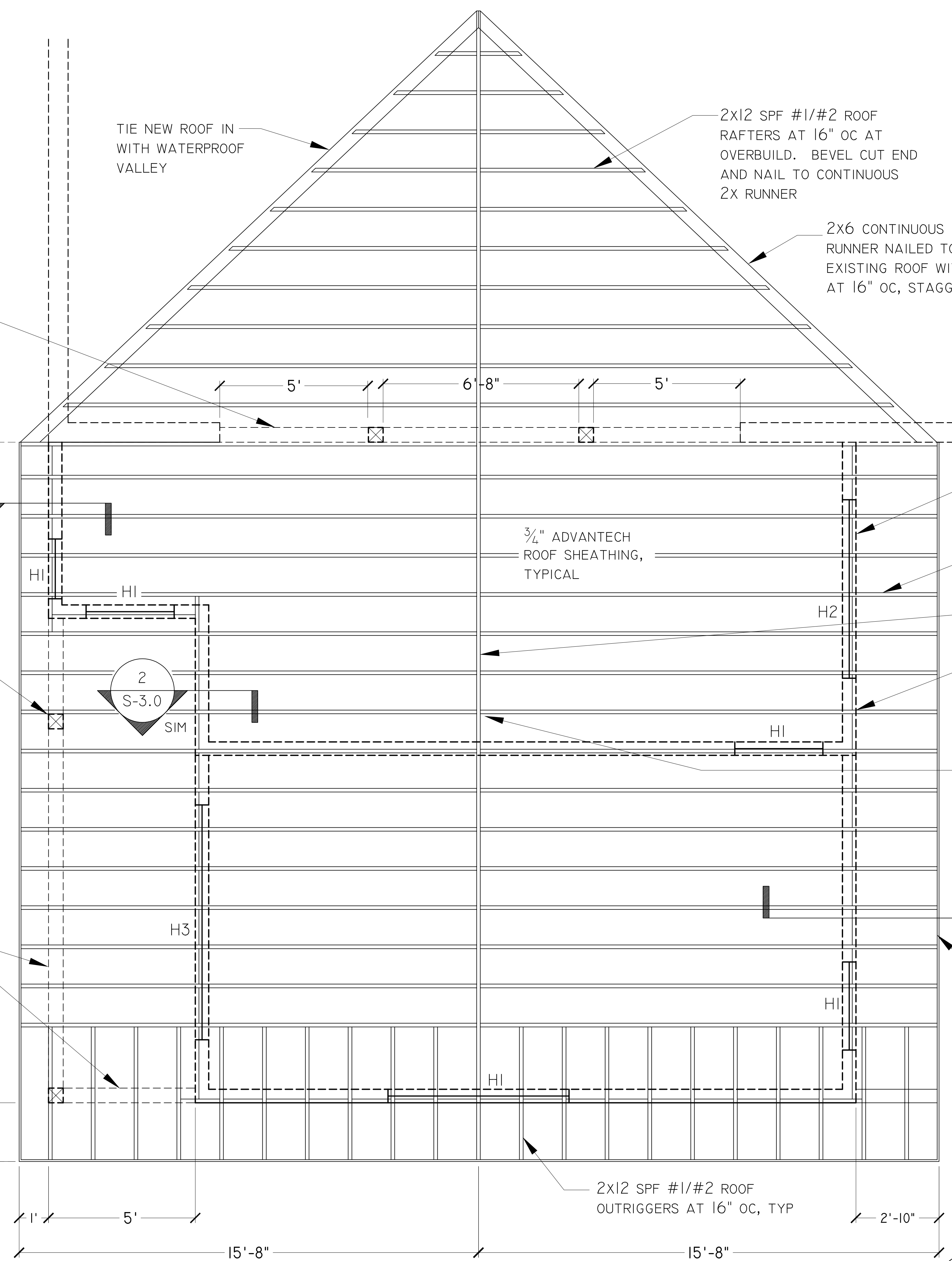

6x6 DLF #1 BEAM BELOW

6x6 DLF #1 POST BELOW, TYP

6x8 DFL #1 BEAM BELOW

TIE NEW ROOF IN WITH WATERPROOF VALLEY

2x12 SPF #1/#2 ROOF RAFTERS AT 16" OC AT OVERBUILD. BEVEL CUT END AND NAIL TO CONTINUOUS 2X RUNNER

2x6 CONTINUOUS RUNNER NAILED TO EXISTING ROOF WITH 10D AT 16" OC, STAGGERED.

3/4" ADVANTECH ROOF SHEATHING, TYPICAL

2x8 BLOCKING BETWEEN RAFTERS ALONG ENTIRE PERIMETER

2x12 SPF #1/#2 ROOF RAFTERS AT 16" OC, TYP

2x12 SPF #1/#2 CONTINUOUS ROOF RIDGE

H2.5A HURRICANE TIE BY SIMPSON STRONG-TIE AT EACH RAFTER. FASTEN WITH (5) 8 NAILS EACH LEG

LRU210Z RAFTER HANGER BY SIMPSON STRONG-TIE AT EACH RAFTER. FASTEN WITH (6) 10D NAILS TO THE FACE AND (7) 10D NAILS TO THE JOIST

1x12 FASCIA BOARD, TYP

HEADER SCHEDULE			
MARK	HEADER SIZE	JAMB STUDS	
		JACK	KING
H1	(3) 2x6	(1) 2x6	(1) 2x6
H2	(3) 2x8	(1) 2x6	(1) 2x6
H3	(3) 2x10	(2) 2x6	(1) 2x6

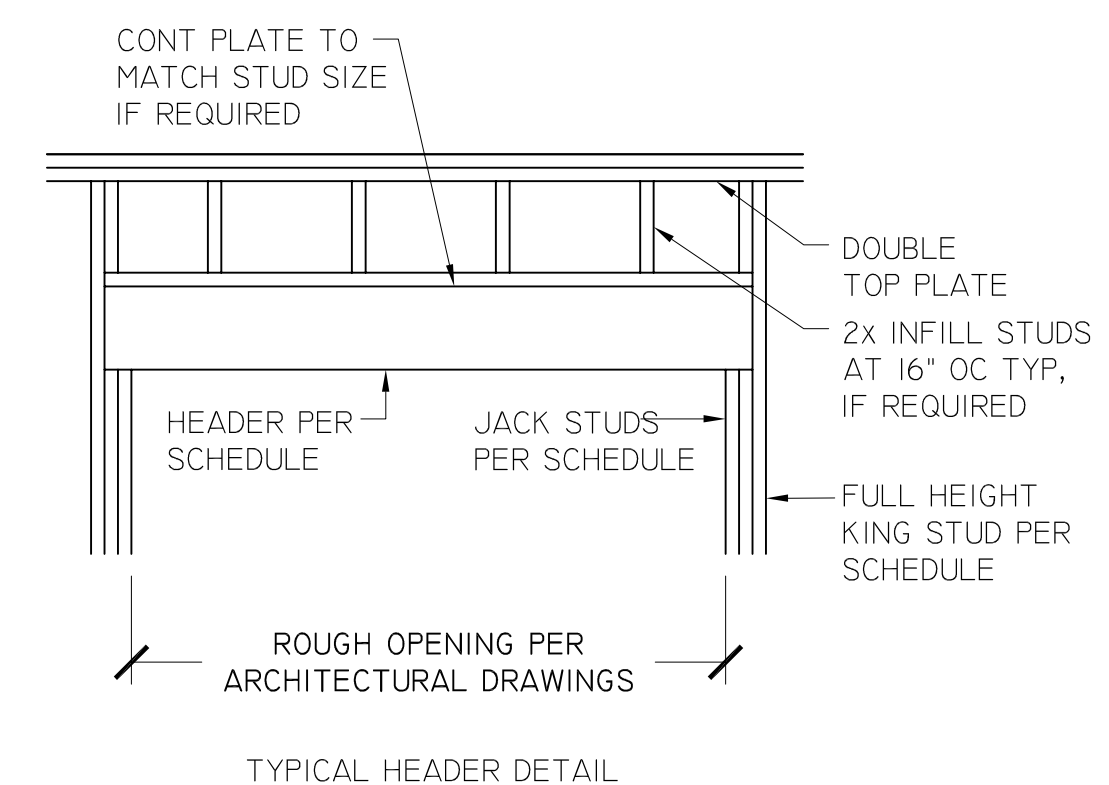

TYPICAL HEADER DETAIL

NOTES:

- HEADERS BUILT-UP WITH DIMENSIONAL LUMBER SHALL REQUIRE 1/2" PLYWOOD FILLER BETWEEN PLYS TO MAINTAIN WIDTH OF WALL.
- ASSEMBLY JACK STUD(S) TO KING STUD WITH (2) 10d NAILS AT 12" OC STAGGERED.

Drawing Scale:
1/2" = 1'-0"

Drawing Date:
04.29.18

Sheet Title:
Kitchen Roof Frame Plan

Sheet Number:
S-1.1

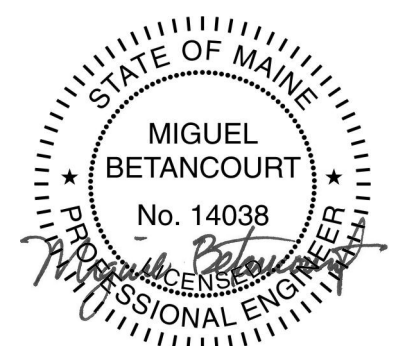

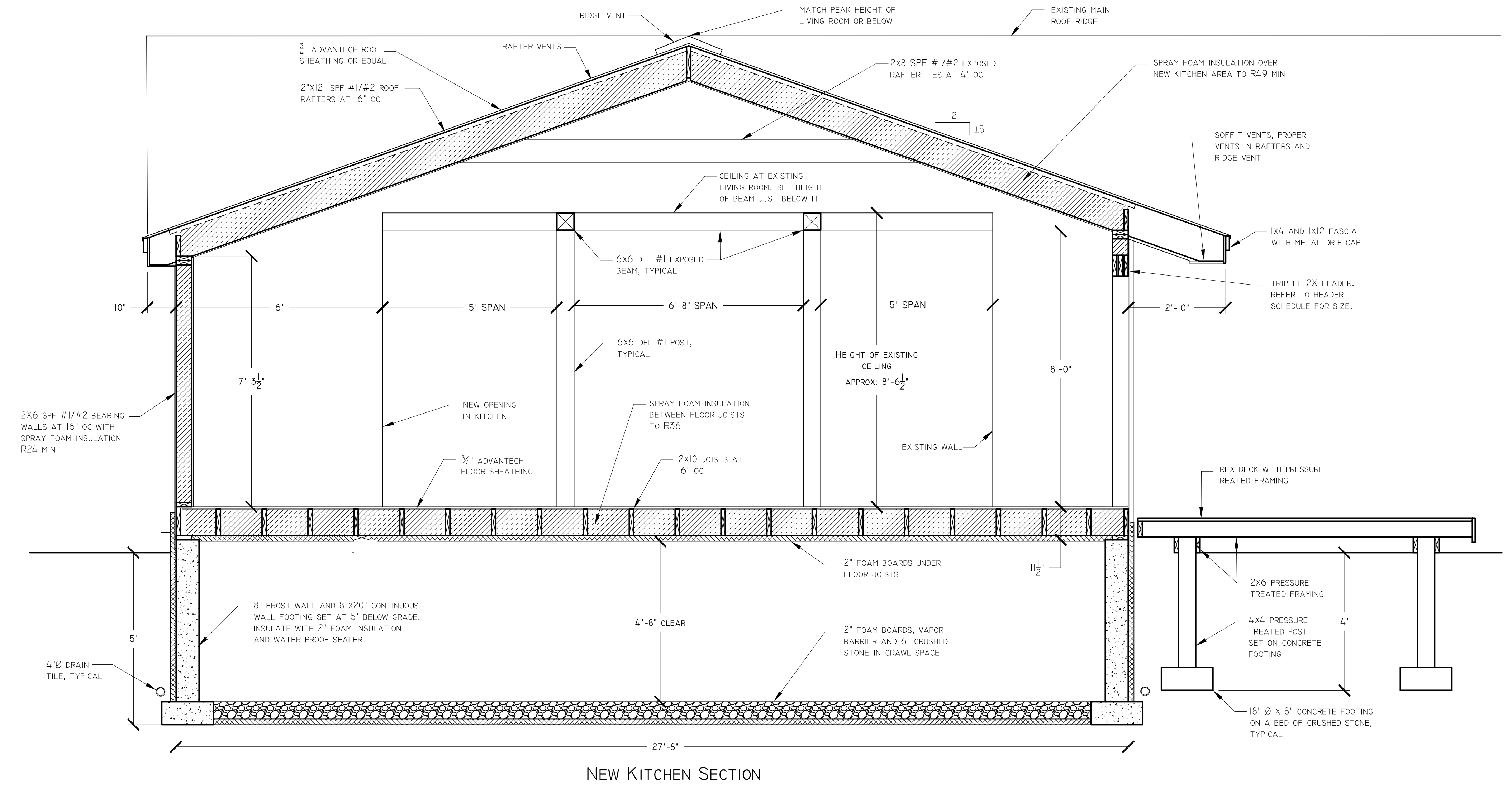

NEW KITCHEN SECTION

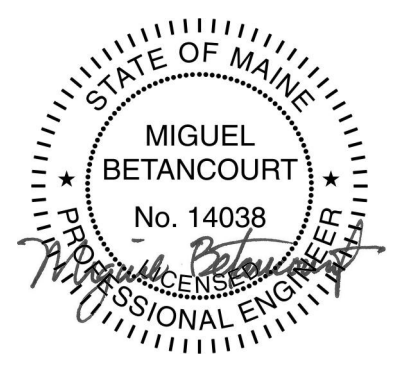

Drawing Scale:
 1/2" = 1'-0"

Drawing Date:
 04.29.18

Sheet Title:
**Proposed
 Kitchen
 Section**

Sheet Number:
S-2.0

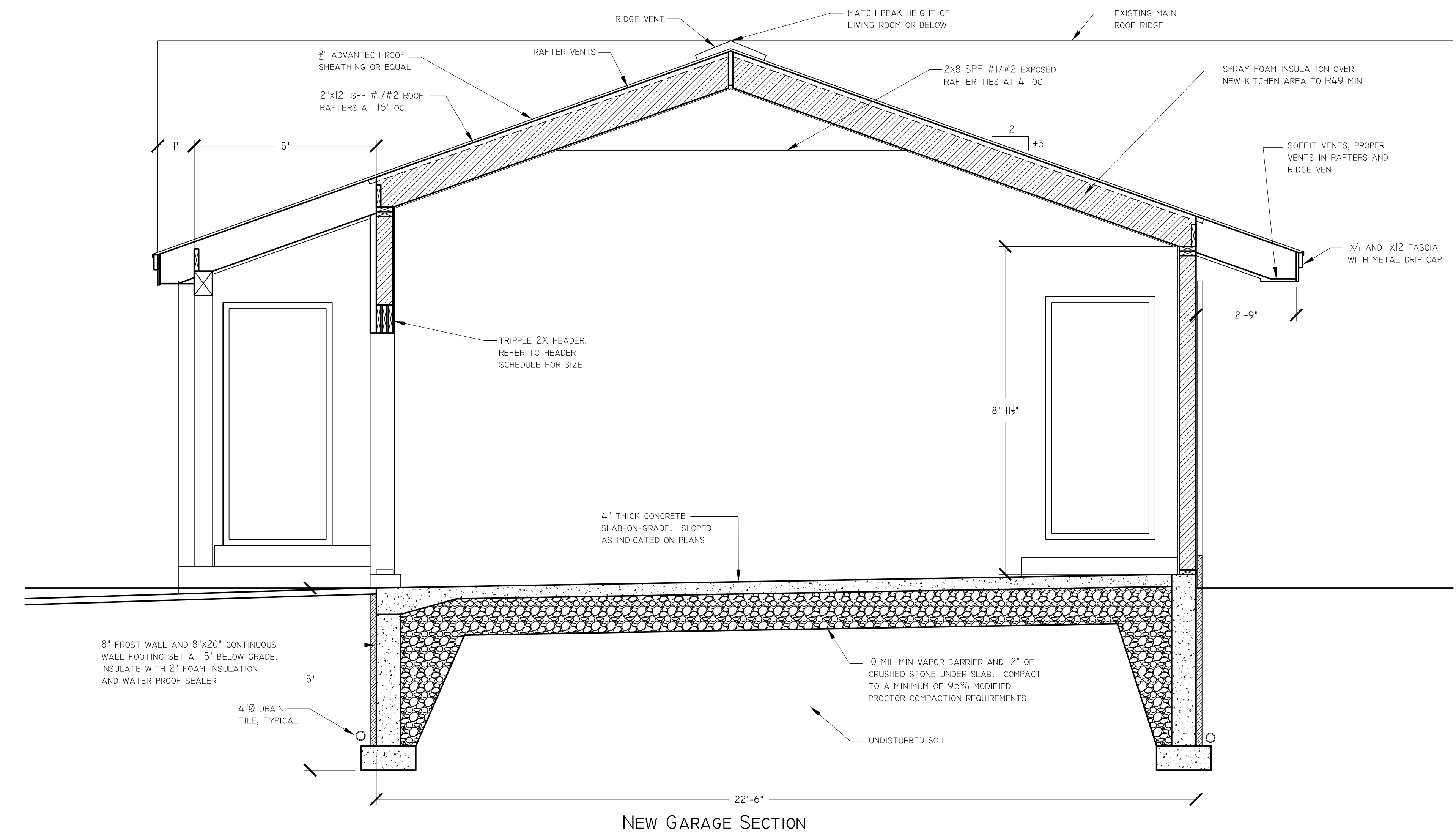

NEW GARAGE SECTION

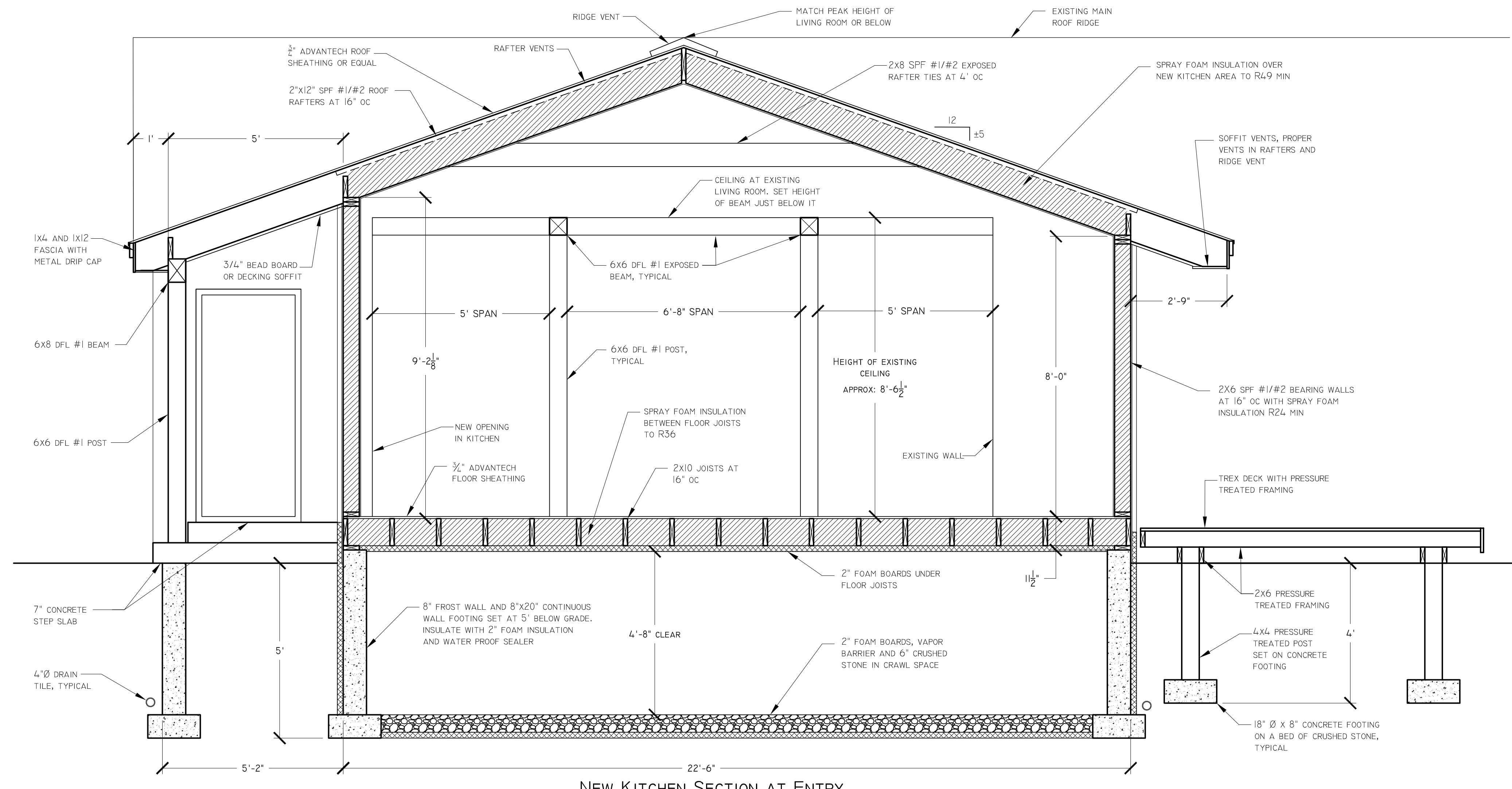

NEW KITCHEN SECTION AT ENTRY

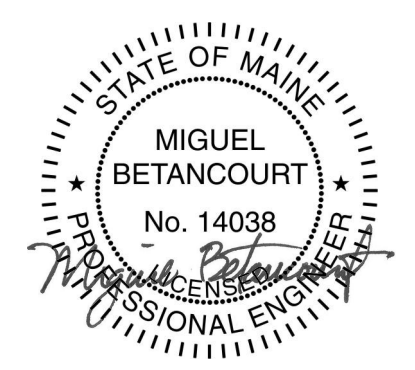

Drawing Scale:
 1/2" = 1'-0"

Drawing Date:
 04.29.18

Sheet Title:
Proposed Kitchen/Garage Section

Sheet Number:
S-2.1

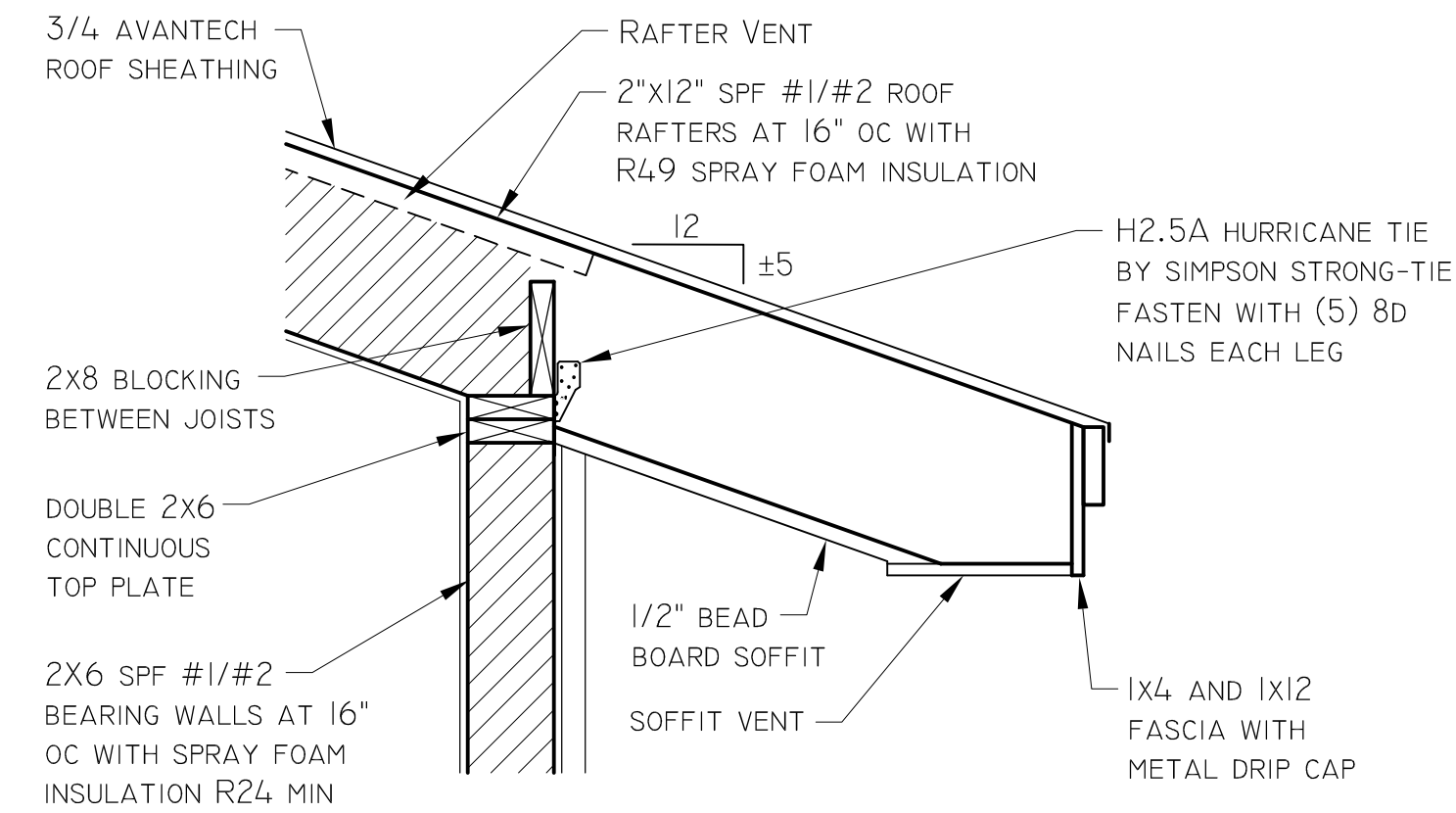

2 Typical Rafter Detail

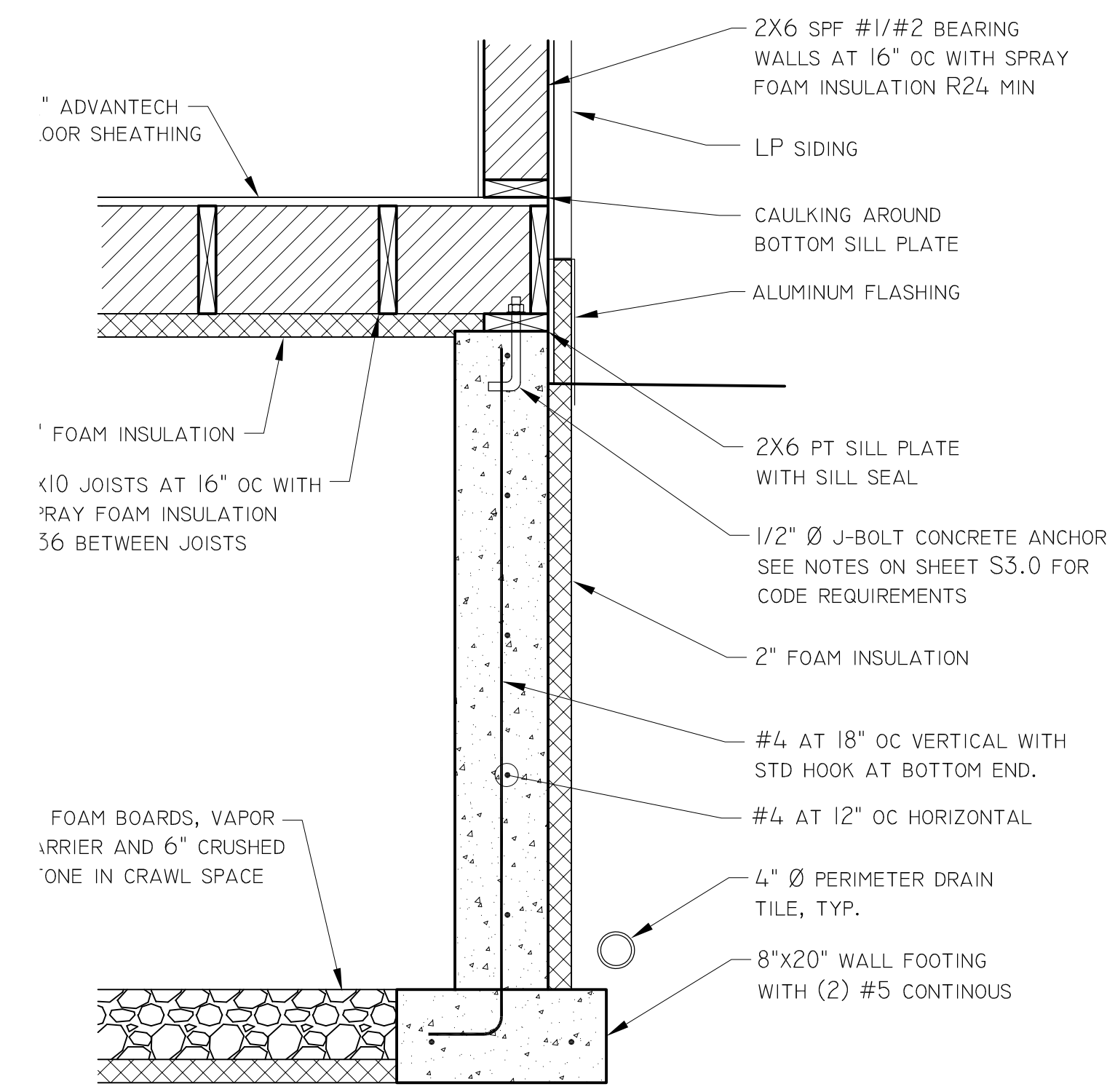

1 Typical Concrete Foundation Wall Detail

Basement Ventilation:
Use a Class 1 vapor retarder material for the entire foundation floor. provide the minimum net area of 1 square foot for each 1,500 square feet of under floor area space. As a minimum, there shall be ventilation openings around the perimeter of the structure, one shall be within 3 feet on either side of each corner of the building. When the structure has a projection in the foundation greater than 8 feet, a ventilation opening shall be required within 3' of each outside corner. Vents shall be located in a readily convenient location, and not under low decks or porches. Vents may be centered on front wall projections for aesthetic reasons.

Foundation Anchors:
Wood sole plates at all exterior walls on monolithic slabs, wood sole plates of braced wall panels at building interiors on monolithic slabs, and all wood sill plates shall be anchored to the foundation with anchor bolts spaced a minimum of 6 feet o.c. This project is specified at 4' on center. Bolts shall be at least 1/2-inch (12.7 mm) in diameter and shall extend a minimum of 7 inches (178 mm) into concrete. A nut and washer shall be tightened on each bolt. There shall be a minimum of two bolts per plate section with one bolt located not more than 12 inches (305 mm) or less than 7 bolt diameters from each end of the plate section. Interior bearing wall sole plates on monolithic slab foundation that are not part of a braced wall panel shall be positively anchored with approved fasteners. Sill plates and sole plates shall be protected against decay and termites where required by sections R317 and R318. Vertical reinforcing should align with foundation anchor bolts.

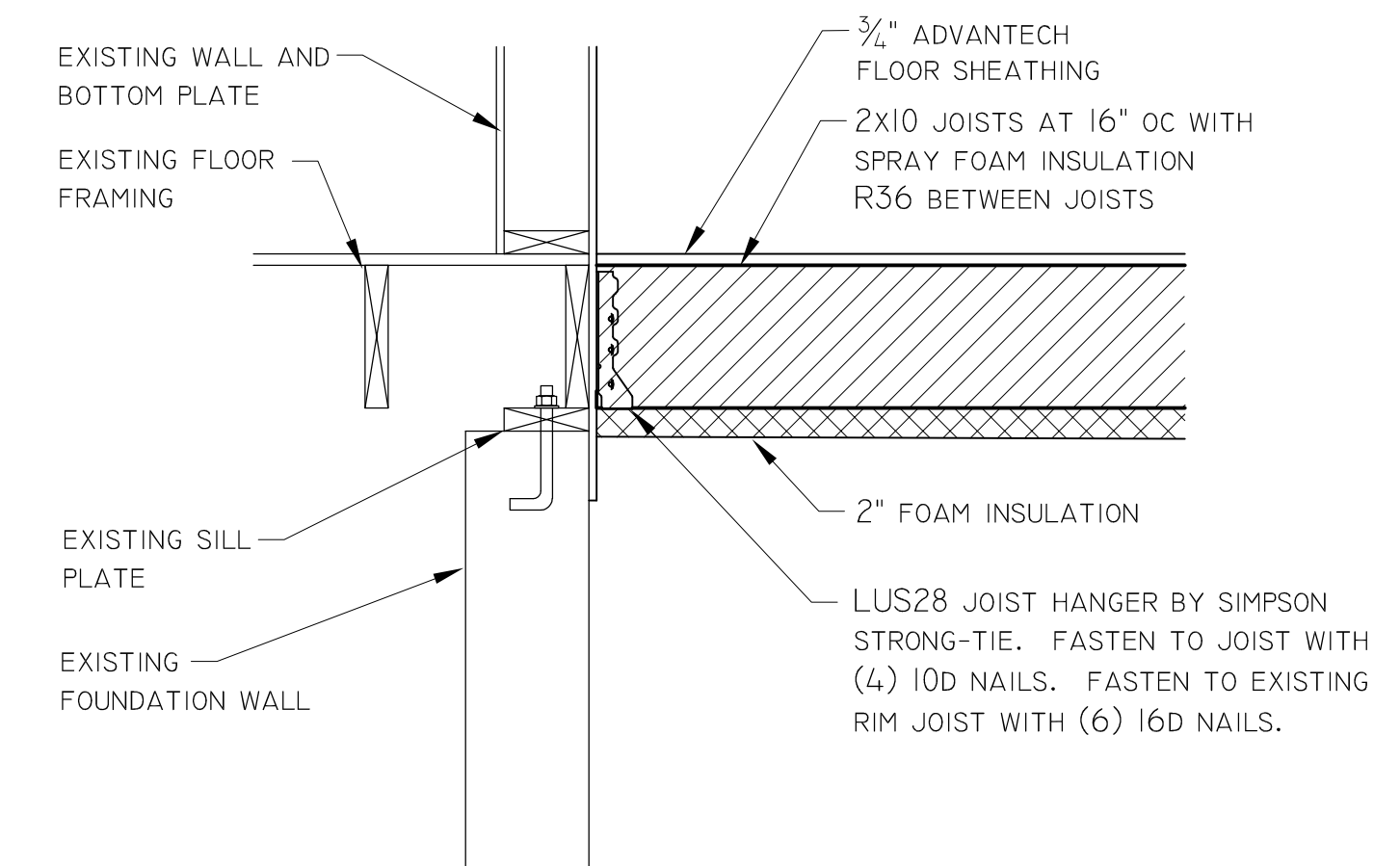

3 Typical Floor Framing Detail at Existing

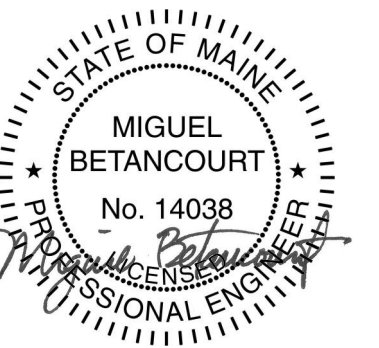

Drawing Scale:
1/2" = 1'-0"

Drawing Date:
04.29.18

Sheet Title:
Construction
Details

Sheet Number:
S-3.0