

Foundation Anchors:

Wood sole plates at all exterior walls on monolithic slabs, wood sole plates of braced wall panels at building interiors on monolithic slabs, and all wood sill plates shall be anchored to the foundation with anchor bolts spaced a minimum of 6 feet o.c. This project is specified at 4' on center. Bolts shall be at least 1/2-inch (12.7 mm) in diameter and shall extend a minimum of 7 inches (178 mm) into concrete. A nut and washer shall be tightened on each bolt. There shall be a minimum of two bolts per plate section with one bolt located not more than 12 inches (305 mm) or less than 7 bolt diameters from each end of the plate section. Interior bearing wall sole plates on monolithic slab foundation that are not part of a braced wall panel shall be positively anchored with approved fasteners. Sill plates and sole plates shall be protected against decay and termites where required by sections R317 and R318. Vertical reinforcing should align with foundation anchor bolts.

Basement Ventilation:

Use a Class 1 vapor retarder material for the entire foundation floor. provide the minimum net area of 1 square foot for each 1,500 square feet of under floor area space. As a minimum, there shall be ventilation openings around the perimeter of the structure, one shall be within 3 feet on either side of each corner of the building. When the structure has a projection in the foundation greater than 8 feet, a ventilation opening shall be required within 3' of each outside corner. Vents shall be located in a readily convenient location, and not under low decks or porches. Vents may be centered on front wall projections for aesthetic reasons.

1 Typical Concrete Frost Wall Details and Sill Plate.

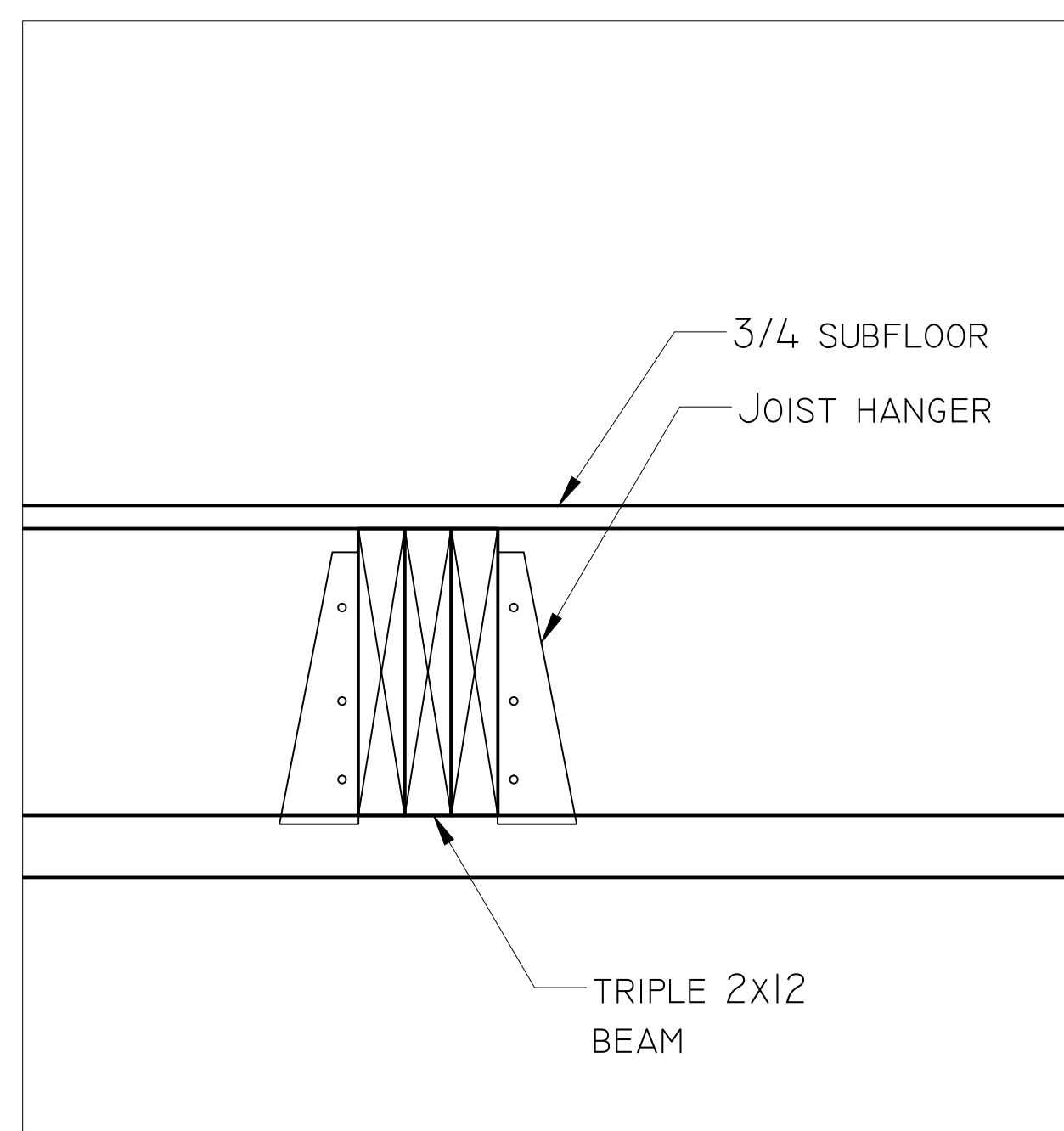

2 Typical Joist Hanger

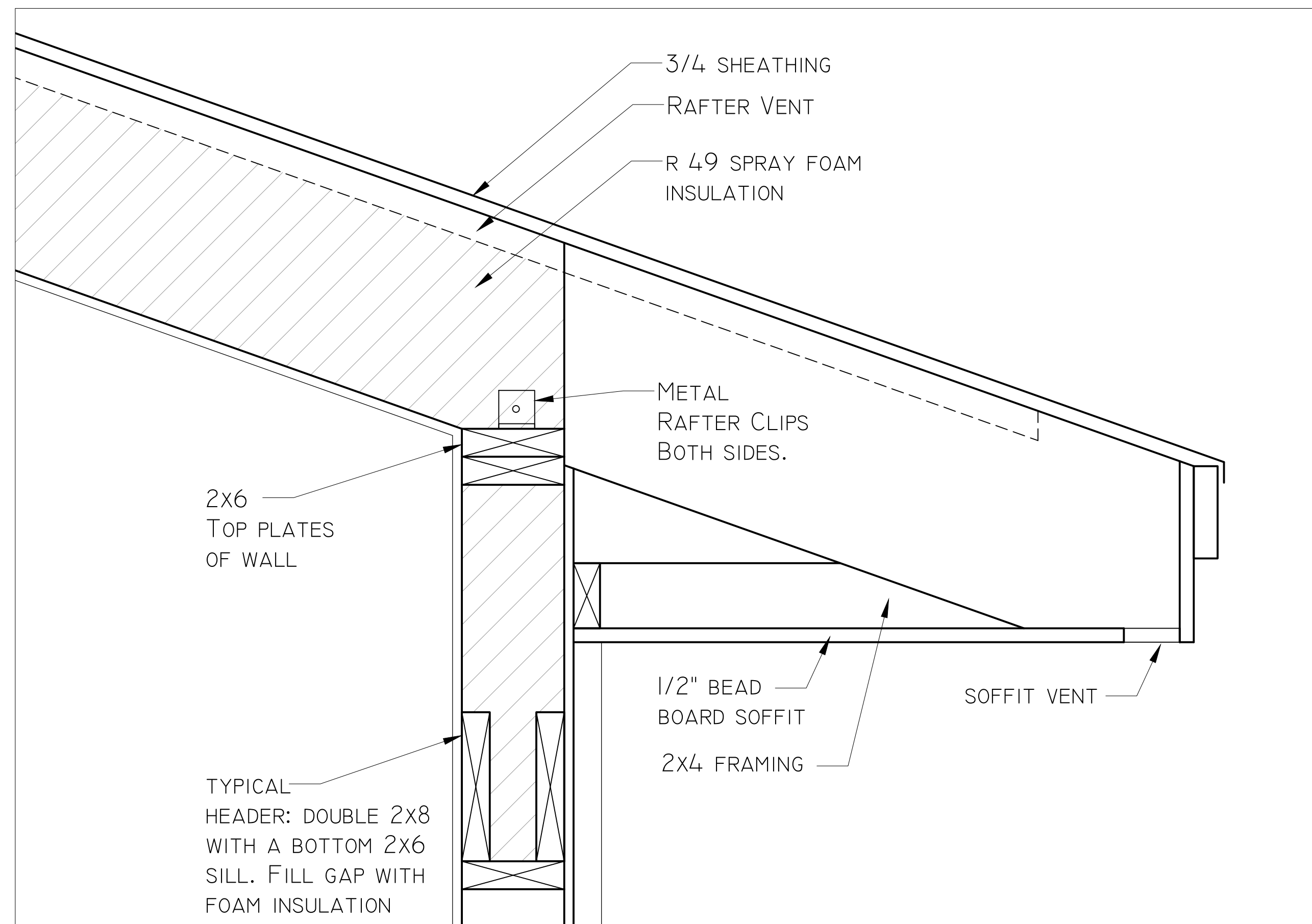

3 Typical Rafter and Header Detail