

1 Callout of Section @ Garage
1 1/2" = 1'-0"

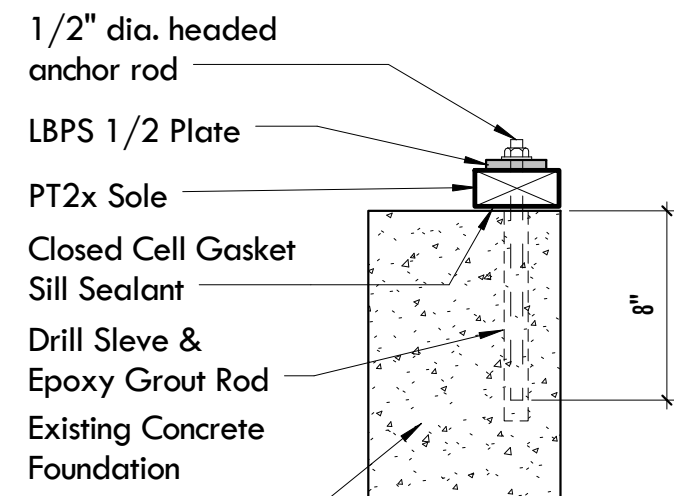

Place @ 48" o.c. & within 8" of corners (both sides) along bearing walls

Locate Anchor Bolts 6'-0" o.c. Maximum

4 Anchor Bolt Detail
1 1/2" = 1'-0"

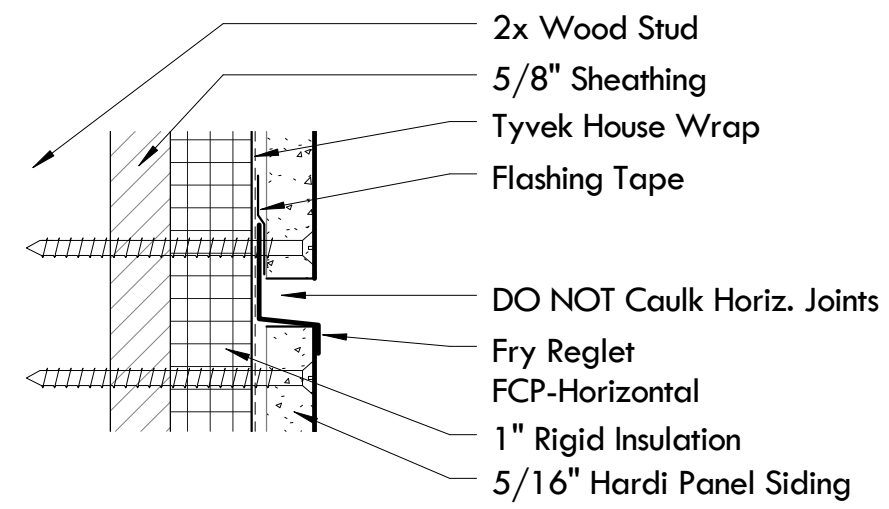

2 Reveal - Cement Panel - Horizontal
6" = 1'-0"

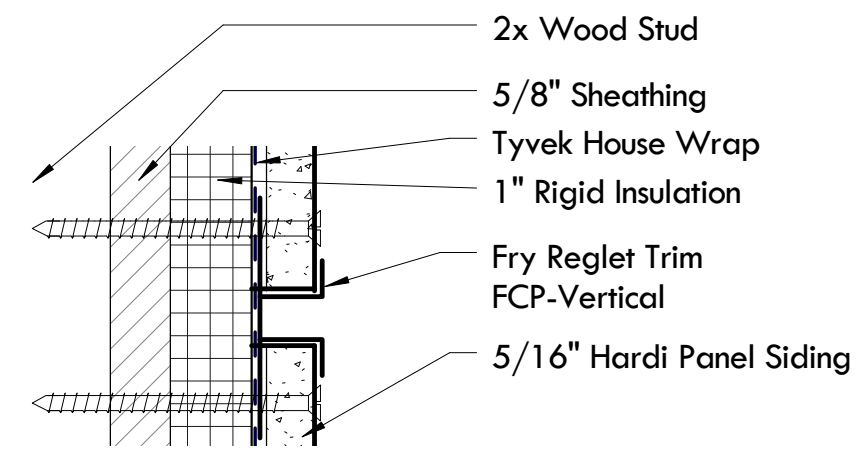

3 Reveal - Cement Panel - Vertical
6" = 1'-0"

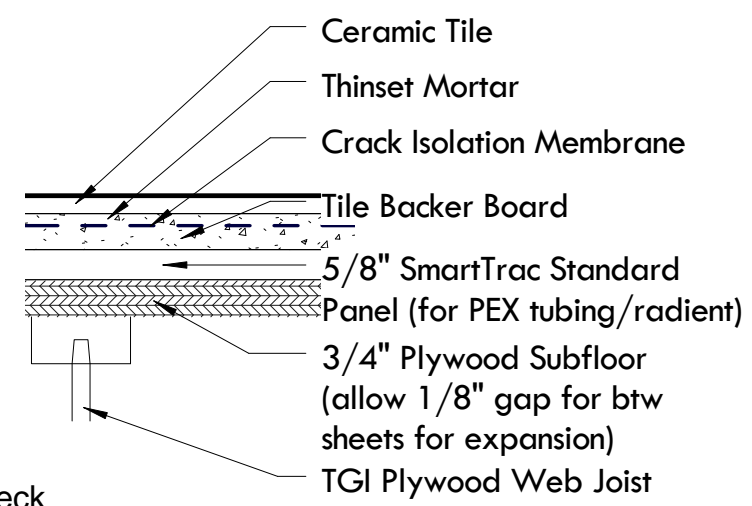

5 Typical Floor Deck
3" = 1'-0"

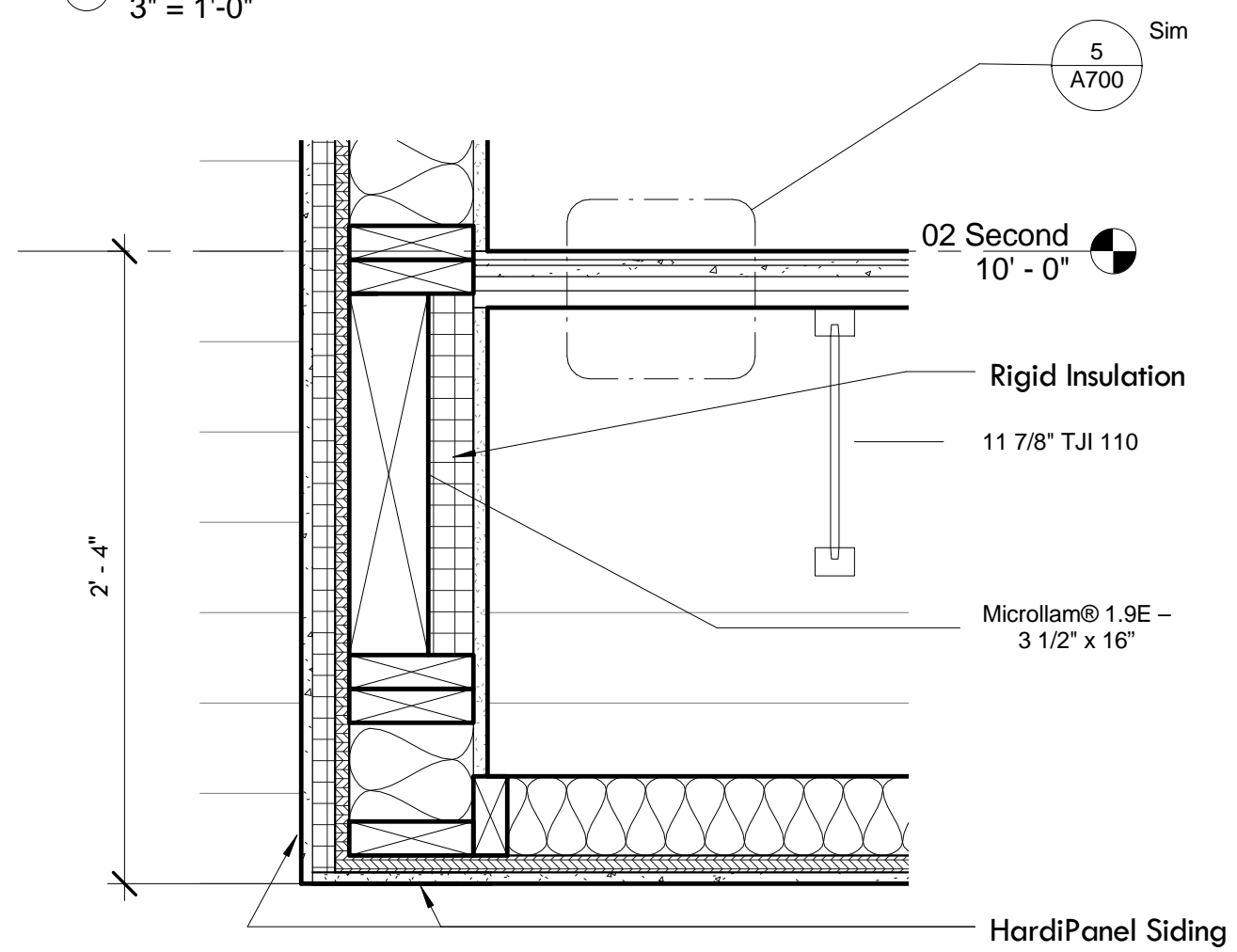

9 Callout of Wall Section @ Entrance
1 1/2" = 1'-0"

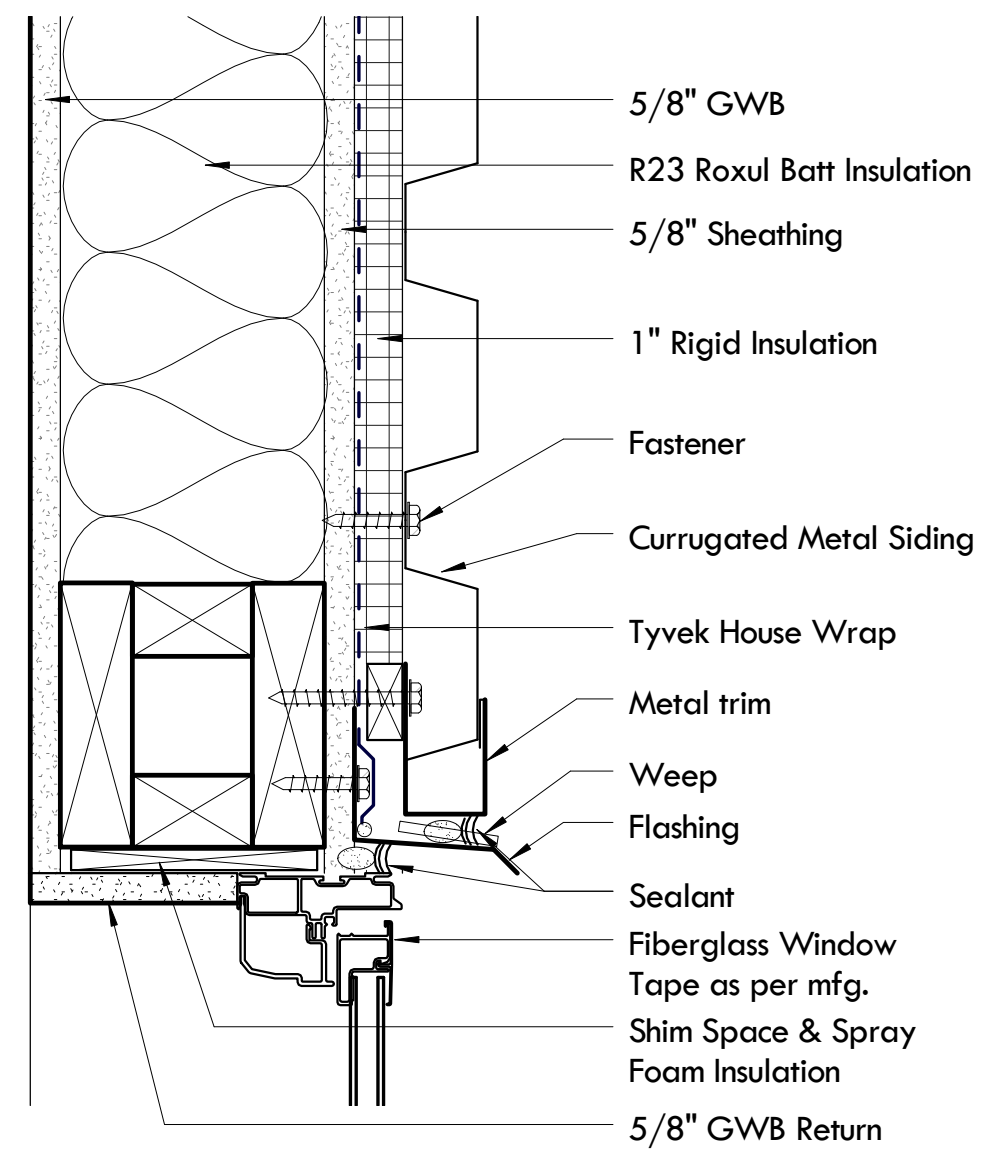

6 Head @ Metal Siding Panel
3" = 1'-0"

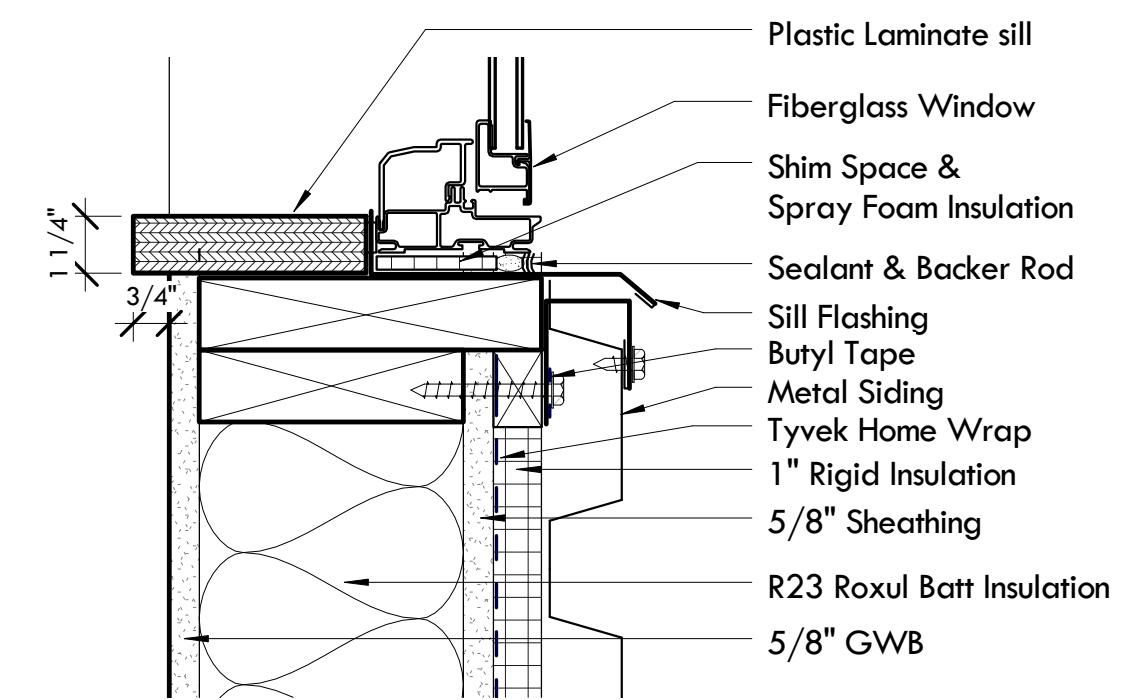

7 Sill @ Metal Siding Panel
3" = 1'-0"

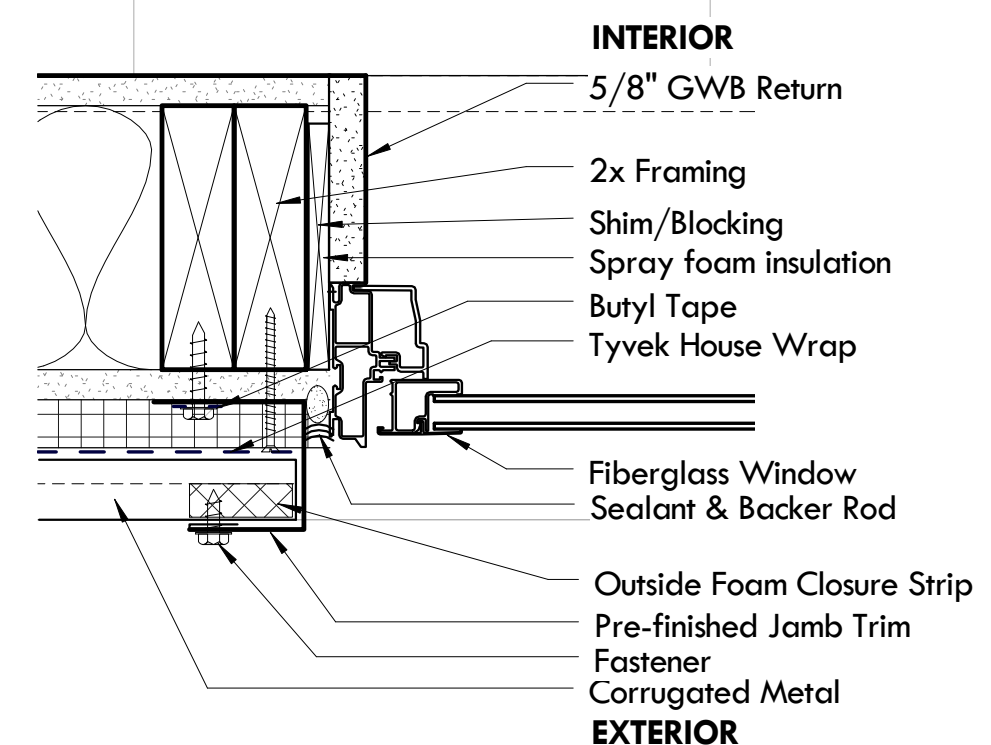

8 Jamb @ Metal Panel Siding
3" = 1'-0"

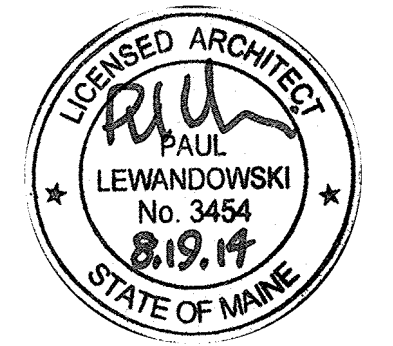

A700

Scale As indicated

© 2014 Paul Lewandowski

8/19/2014 9:11:05 PM