

City of Portland, Maine - Building or Use Permit Application
 389 Congress Street, 04101 Tel: (207) 874-8703, Fax: (207) 874-8716

PERMIT ISSUED		Permit No: 02-0917	Issue Date: AUG 23 2002	CBL: 137 C011001
Location of Construction: 865 Forest Ave	Owner Name: Heather Piece Inc	Owner Address: 1366 Westbrook St		Phone:
Business Name:	Contractor Name: Restaurant Equipement of Maine	Contractor Address: 75 York Street Portland		Phone: 2077737376
Lessee/Buyer's Name	Phone:	Permit Type: Amendment to Commercial		Zone:

Past Use: Restaurant	Proposed Use: Restaurant	Permit Fee: \$30.00	Cost of Work: \$30.00	CEO District: 2
Proposed Project Description: Amendment to Permit #020767/Change Hood on Kitchen Vent		FIRE DEPT: <input checked="" type="checkbox"/> Approved <input type="checkbox"/> Denied	INSPECTION: Use Group: A-3 Type: NA <i>8/23/02</i>	
		Signature: <i>[Signature]</i>	Signature: <i>[Signature]</i>	
PEDESTRIAN ACTIVITIES DISTRICT (P.A.D.)				
Action: <input type="checkbox"/> Approved <input type="checkbox"/> Approved w/Conditions <input type="checkbox"/> Denied				
Signature: _____ Date: _____				

Permit Taken By: gad	Date Applied For: 08/13/2002	Zoning Approval		
1. This permit application does not preclude the Applicant(s) from meeting applicable State and Federal Rules. 2. Building permits do not include plumbing, septic or electrical work. 3. Building permits are void if work is not started within six (6) months of the date of issuance. False information may invalidate a building permit and stop all work..		Special Zone or Reviews <input type="checkbox"/> Shoreland <input type="checkbox"/> Wetland <input type="checkbox"/> Flood Zone <input type="checkbox"/> Subdivision <input type="checkbox"/> Site Plan Maj <input type="checkbox"/> Minor <input type="checkbox"/> MM <input type="checkbox"/> Date: _____	Zoning Appeal <input type="checkbox"/> Variance <input type="checkbox"/> Miscellaneous <input type="checkbox"/> Conditional Use <input type="checkbox"/> Interpretation <input type="checkbox"/> Approved <input type="checkbox"/> Denied Date: _____	Historic Preservation <input type="checkbox"/> Not in District or Landmark <input type="checkbox"/> Does Not Require Review <input type="checkbox"/> Requires Review <input type="checkbox"/> Approved <input type="checkbox"/> Approved w/Conditions <input type="checkbox"/> Denied Date: _____

CERTIFICATION

I hereby certify that I am the owner of record of the named property, or that the proposed work is authorized by the owner of record and that I have been authorized by the owner to make this application as his authorized agent and I agree to conform to all applicable laws of this jurisdiction. In addition, if a permit for work described in the application is issued, I certify that the code official's authorized representative shall have the authority to enter all areas covered by such permit at any reasonable hour to enforce the provision of the code(s) applicable to such permit.

SIGNATURE OF APPLICANT	ADDRESS	DATE	PHONE
RESPONSIBLE PERSON IN CHARGE OF WORK, TITLE		DATE	PHONE

02-0917

All Purpose Building Permit Application

If you or the property owner owes real estate or personal property taxes or user charges on any property within the City, payment arrangements must be made before permits of any kind are accepted.

Location/Address of Construction: <u>865 Forest Ave</u>		
Total Square Footage of Proposed Structure	Square Footage of Lot	
Tax Assessor's Chart, Block & Lot Chart# <u>137</u> Block# <u>C</u> Lot# <u>011</u>	Owner: <u>Heather Piece INC.</u> <u>1366 Westbrook St.</u>	Telephone:
Lessee/Buyer's Name (If Applicable)	Applicant name, address & telephone: <u>THIC INC.</u> <u>865 FOREST AVE PORTLAND ME 04103.</u>	Cost Of Work: \$ 87500.00 Fee: \$ <u>30.00</u>
Current use: <u>restaurant</u>		
If the location is currently vacant, what was prior use: _____		
Approximately how long has it been vacant: <u>Restaurant then Restaurant</u>		
Proposed use: <u>Cooked Hood for kitchen</u>		
Project description: <u>amendment to permit # 02 0767</u>		
Contractor's name, address & telephone: <u>Restaurant Equipment Service of Maine</u> <u>45 York St. Portland 04101</u>		
Who should we contact when the permit is ready: <u>Tony Nguyen</u> <u>207 773 7376</u>		
Mailing address: <u>cell</u>		
We will contact you by phone when the permit is ready. You must come in and pick up the permit and review the requirements before starting any work, with a Plan Reviewer. A stop work order will be issued and a \$100.00 fee if any work starts before the permit is picked up. PHONE: # <u>878-7926</u> <u>cell 318-2377</u>		

IF THE REQUIRED INFORMATION IS NOT INCLUDED IN THE SUBMISSIONS THE PERMIT WILL BE AUTOMATICALLY DENIED AT THE DISCRETION OF THE BUILDING/PLANNING DEPARTMENT, WE MAY REQUIRE ADDITIONAL INFORMATION IN ORDER TO APPROVE THIS PERMIT.

I hereby certify that I am the Owner of record of the named property, or that the owner of record authorizes the proposed work and that I have been authorized by the owner to make this application as his/her authorized agent. I agree to conform to all applicable laws of this jurisdiction. In addition, if a permit for work described in this application is issued, I certify that the Code Official's authorized representative shall have the authority to enter all areas covered by this permit at any reasonable hour to enforce the provisions of the codes applicable to this permit.

Signature of applicant: <u>Tony Nguyen</u>	Date: <u>8/13/02.</u>
--	-----------------------

This is NOT a permit, you may not commence ANY work until the permit is issued. If you are in a Historic District you may be subject to additional permitting and fees with the Planning Department on the 4th floor of City Hall.

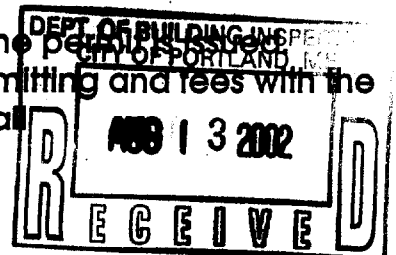

DISPLAY THIS CARD ON PRINCIPAL FRONTAGE OF WORK CITY OF PORTLAND

Please Read
Application And
Notes, If Any,
Attached

BUILDING INSPECTION

Permit Number: 020917

PERMIT

This is to certify that Heather Piece Inc /Restaurant Equipement
has permission to Amendment to Permit #0207 Change food on when Ver
AT 865 Forest Ave 137 C011001

provided that the person or persons, firm or corporation accepting this permit shall comply with all of the provisions of the Statutes of Maine and of the ordinances of the City of Portland regulating the construction, maintenance and use of buildings and structures, and of the application on file in this department.

Apply to Public Works for street line and grade if nature of work requires such information.

Notification of inspection must be given and written permission procured before this building or part thereof is altered or closed-in. **HEAVY NOTICE IS REQUIRED.**

A certificate of occupancy must be procured by owner before this building or part thereof is occupied.

OTHER REQUIRED APPROVALS

Fire Dept. *[Signature]*
Health Dept. _____
Appeal Board _____
Other _____
Department Name

[Signature] 8/22/02
Director - Building Inspection Services

PENALTY FOR REMOVING THIS CARD

Application ID Number:

Delete

Save

Close

Department:

Status:

Reviewer:

Comments:

Approval Date:

Given On Date:

OK to Issue Permit

Name:

Date:

Date 2:

Conditions Section:

Add New Condition From

Add New Condition

Delete Condition

Must Comply with 1993 BOCA Mechanical Code.

Create Date:

By:

Update Date:

By:

MADE IN AMERICA



American Hood Systems INC.

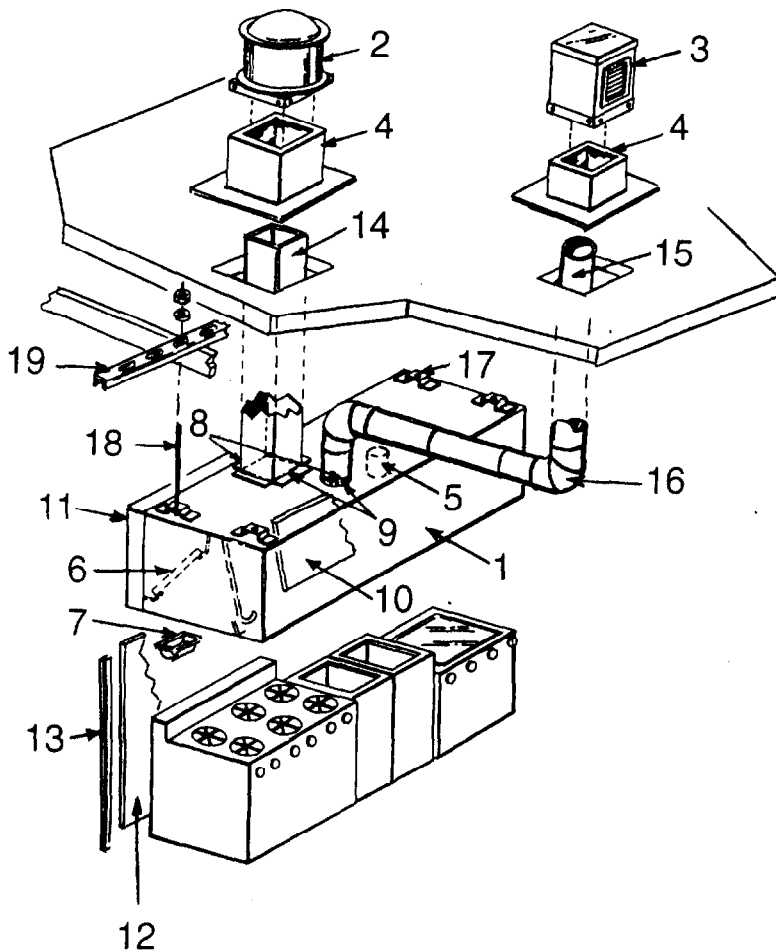

INSTALLATION DIAGRAM

EQUIPMENT LIST

- ★ 1. Exhaust Hood
- ★ 2. Exhaust Fan
- ★ 3. Make Up-Air Fan
- ★ 4. Roof Curbs
- ★ 5. Vapor-Proof Light
- ★ 6. Grease Filters
- ★ 7. Grease Cup
- 8. Duct Openings
- 9. Duct Collars
- 10. Insulated Mua
- 11. Air Gap
- 12. Stainless Steel Back Splash
- 13. Trim Strips
- 14. Exhaust Duct
- 15. Mua Duct
- 16. 90° Elbows and/ or Offsets for Exhaust and Mua
- 17. Hanger Brackets
- 18. Full Threaded Rod
- 19. Unistrut

★ = Included in Package
 ● = Optional Equipment

HOOD SYSTEMS BUILT FOR
 EQUIPMENT FOR THE REMOVAL
 OF SMOKE AND GREASE LADEN
 VAPORS FROM COMMERCIAL
 COOKING EQUIPMENT

HOOD SYSTEMS
 BUILT FOR
 FOOD SERVICE
 EQUIPMENT
 TO STD. NSF-2



FANS



MEMBER

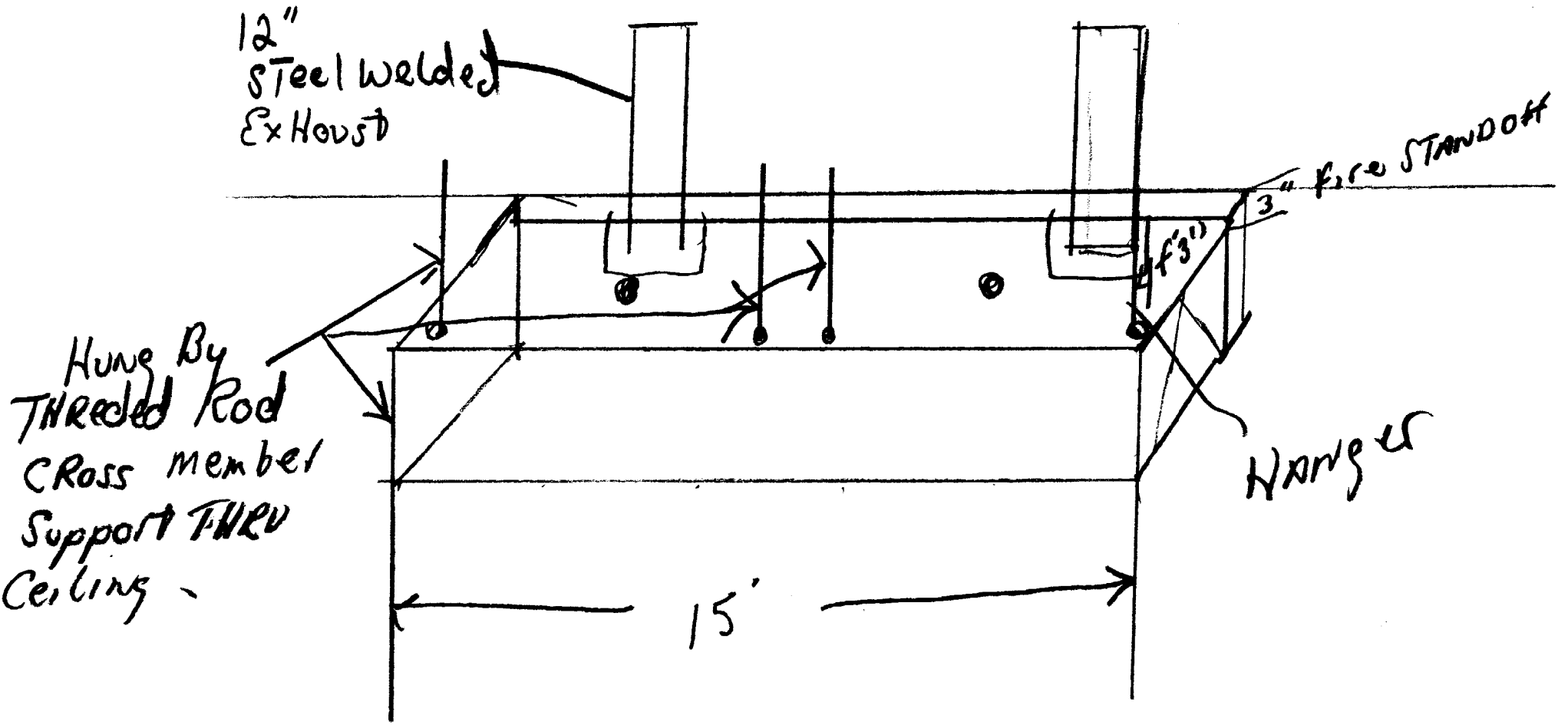

ALL clearance insulation where applicable

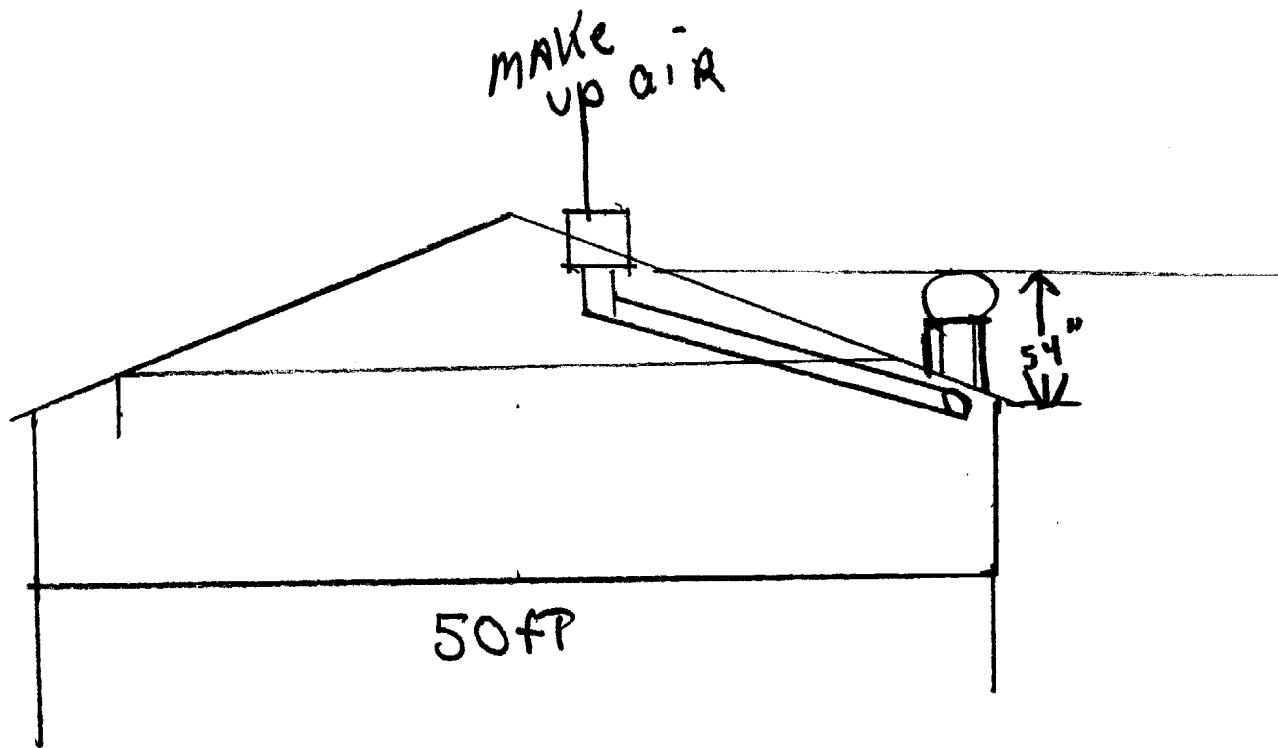

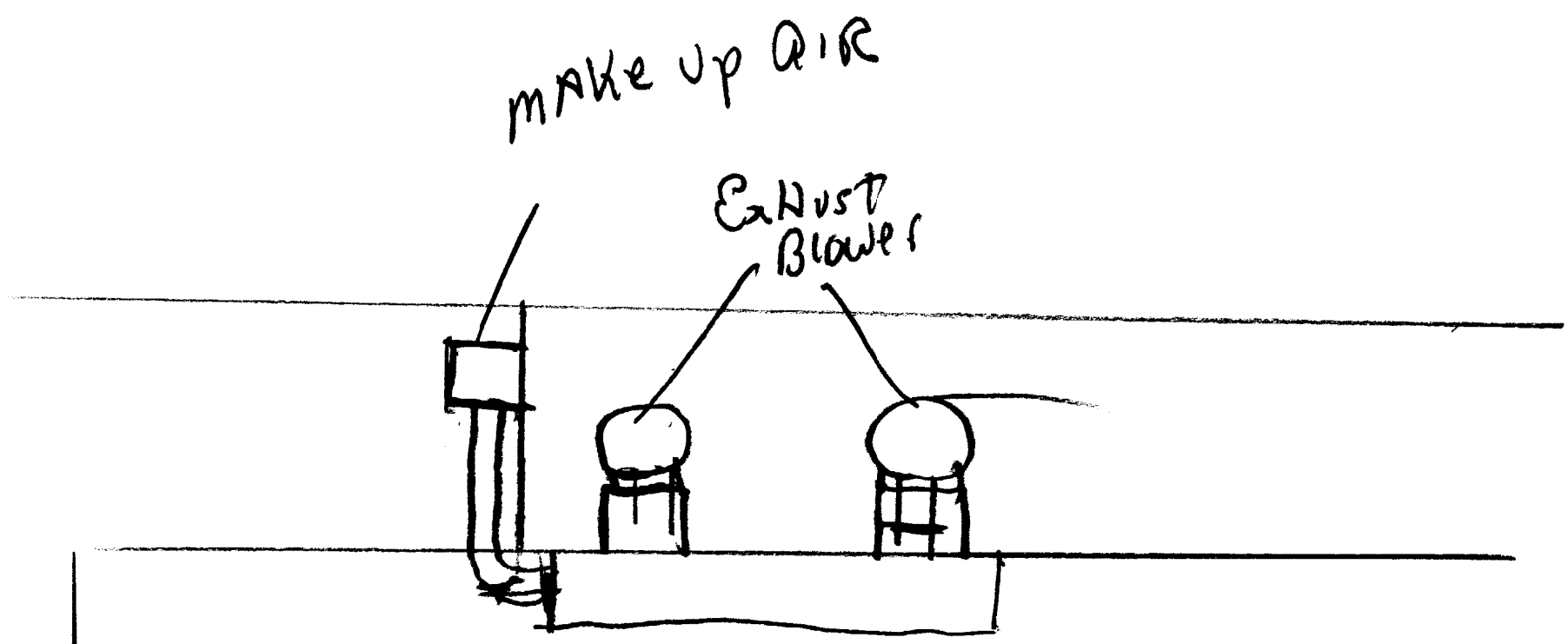

Back View

20' To Top of Blowers

AFTER

