

4 SECTION DETAIL AT FLAT ROOF
1/2" = 1'-0"

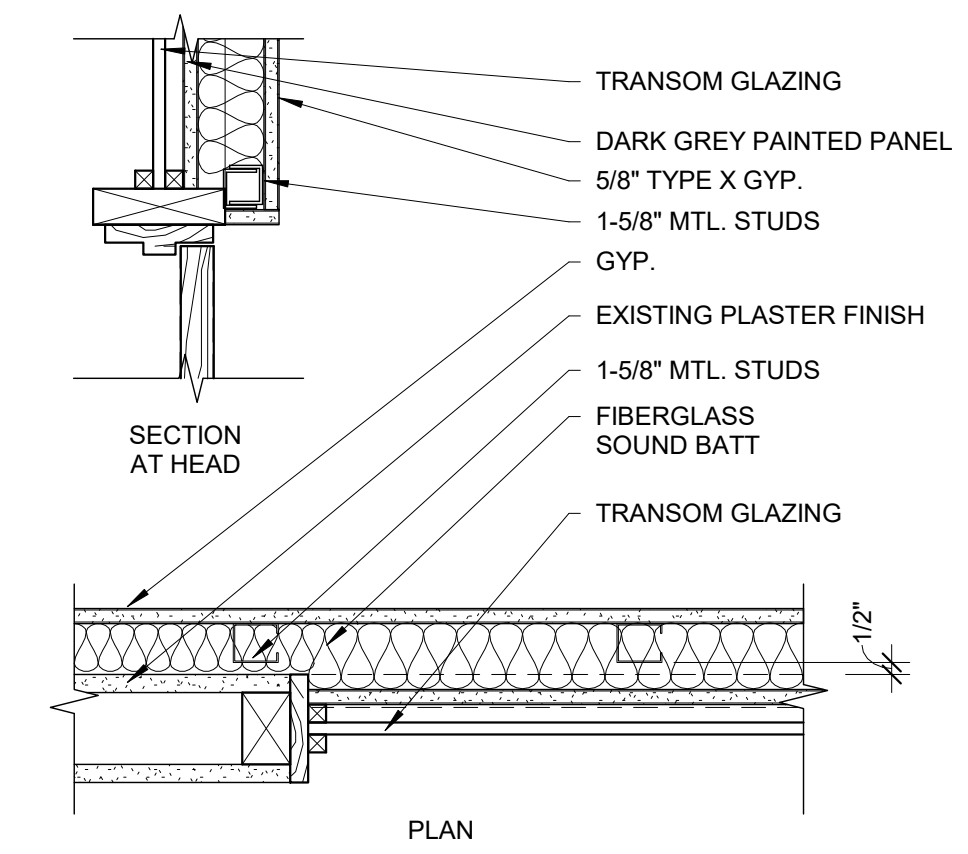

3 EXISTING TRANSOM RATING DETAIL
1 1/2" = 1'-0"

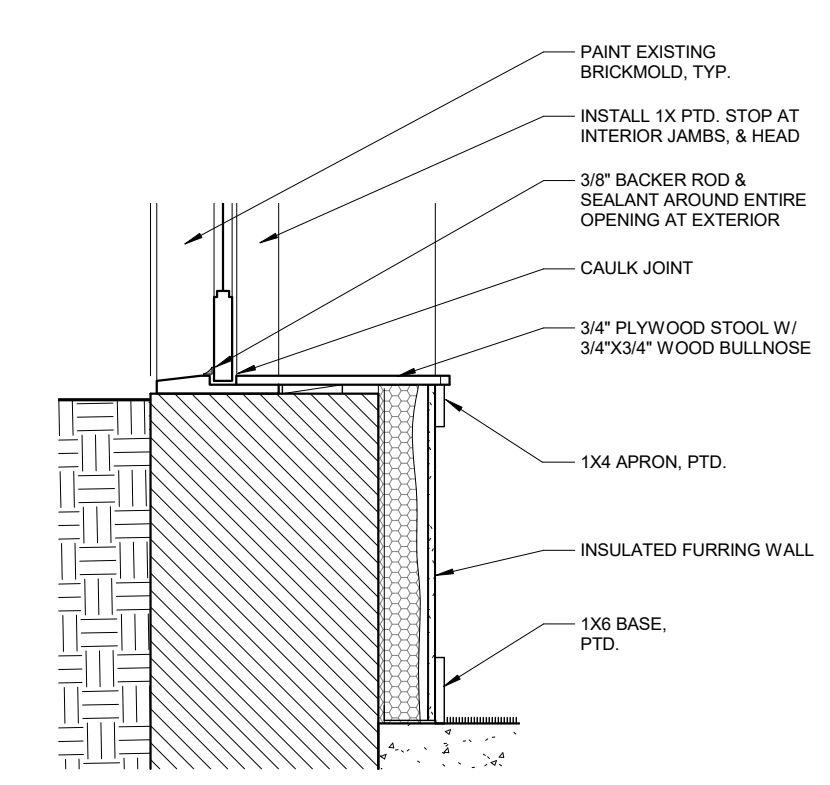

2 COURTYARD WINDOW SECTION
3/4" = 1'-0"

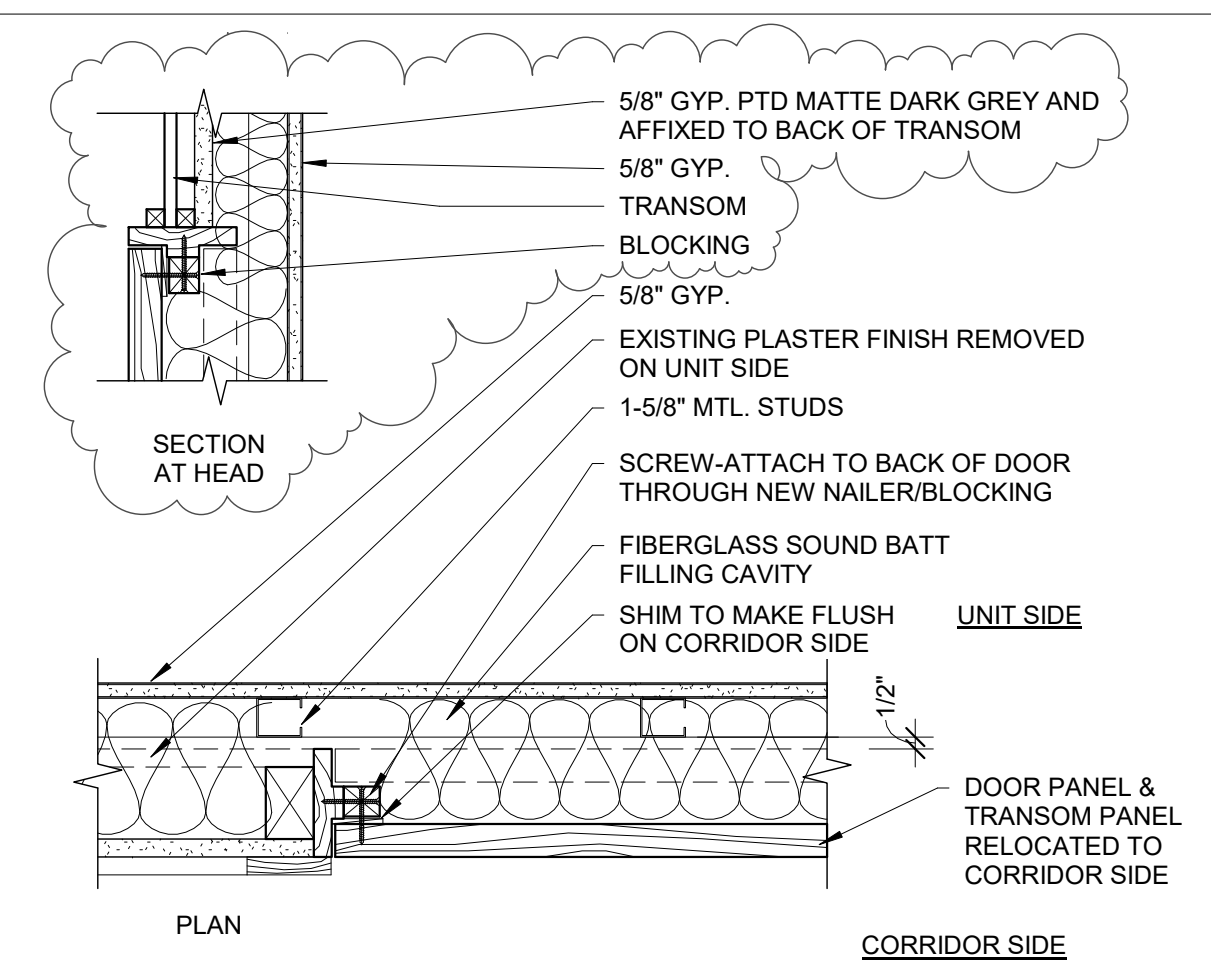

1 HISTORIC FIXED DOOR DETAIL
1 1/2" = 1'-0"

Prepared For: MOTHERHOUSE LLC	Consultant: ARCHETYPE architects 48 Union Wharf Portland, Maine 04101 (207) 772-6022 ARCHETYPE@ARCHETYPEPA.COM	Project: MOTHERHOUSE SENIOR HOUSING 605 STEVENS AVENUE PORTLAND, MAINE 04103	Revisions: 1 11/15/16 Revisions for City Permit Review	Scale: As indicated	Date: 7 APR 2016	DETAILS	A5.02
---	--	--	---	------------------------	---------------------	----------------	--------------